

1956

FORD

car

Shop Manual

F O R D D I V I S I O N

F O R D M O T O R C O M P A N Y

1 9 5 6

FORD

DAVE GRAHAM

Auto Literature, Inc.

© 2007 All rights reserved
Made in the USA



QUICK REFERENCE INDEX. To use, move either the hand or selection tool directly over the section you desire to reference. Simply click once with the mouse button and the manual will automatically jump to that section.

Shop Manual

Copyright 1955
FORD MOTOR COMPANY
DEARBORN, MICHIGAN
All rights reserved



September, 1955

F O R D D I V I S I O N
F O R D M O T O R C O M P A N Y

FOREWORD

This manual has been prepared to provide information for the proper servicing of 1956 Ford Cars and the 1956 Ford Thunderbird. The manual should be kept where it will be readily available for reference at all times. The service procedures are accompanied by illustrations of many of the service operations. Disassembled views of some of the car units are also given.

The manual is divided into five main parts as listed in the Table of Contents on the following pages.

Part ONE—POWER PLANT—is composed of the various engines and their related systems, which are ignition, fuel, and cooling.

Part TWO—CHASSIS—includes information on the entire power train (clutch, conventional transmission, Overdrive, drive line, rear axle, etc.) and the running gear (frames, springs, suspension, brakes, wheels, tires, steering gear, steering linkages, etc.). Service procedures for the Fordomatic transmission are published in a separate manual.

Part THREE—ELECTRICAL AND ACCESSORIES—covers all of the electrical systems and units (except the ignition system) and all of the accessories (except the Overdrive and Fordomatic).

Part FOUR—BODIES—contains information on the maintenance and repair of all body components, including adjustment and alignment of doors, hoods, and fenders. Window glass adjustments are also included in this part.

Part FIVE—MAINTENANCE AND SPECIFICATIONS—includes complete maintenance and lubrication information, and contains all the specifications necessary for properly servicing Ford cars.

The page headings, throughout the manual, designate the subject matter covered. The heading on each left-hand or even-numbered page indicates the name of the chapter and the heading on each right-hand or odd-numbered page indicates the section covered.

The descriptions and specifications contained in this manual were in effect at the time the book was approved for printing. The Ford Division of Ford Motor Company reserves the right to discontinue models at any time, or change specifications or design, without notice and without incurring obligation.

SERVICE DEPARTMENT
FORD DIVISION
FORD MOTOR COMPANY

TABLE OF CONTENTS

Foreword.....	Page	2
---------------	------	---

Part ONE—POWER PLANT

CHAPTER I—GENERAL ENGINE OVERHAUL, INSPECTION, AND REPAIR

	Page		Page		
Section 1	Trouble Shooting.....	5	Section 6	Timing Chain, Sprockets and Camshaft.....	20
2	Tune-Up.....	8	7	Flywheel, Crankshaft and Main Bearings.....	22
3	Engine Removal and Installation.....	10	8	Cylinder Block, Pistons, Piston Rings, and Connecting Rods and Bearings.....	25
4	Intake and Exhaust Manifolds.....	14	9	Oil Pan and Oil Pump.....	29
5	Rocker Mechanism, Cylinder Head, Valves, Valve Lash Adjustment, and Valve Timing..	15	10	Exhaust System.....	30

CHAPTER II—6-CYLINDER ENGINE

Section 1	Engine Steady Rest.....	31	Section 7	Flywheel, Crankshaft, and Main Bearings.....	39
2	Manifolds.....	32	8	Connecting Rods and Bearings, Pistons, Pins, and Rings.....	42
3	Cylinder Head and Valves.....	33	9	Oil Pan, Oil Filter and Oil Pump.....	44
4	Crankshaft Damper.....	36	10	Exhaust System.....	45
5	Cylinder Front Cover and Crankshaft Oil Seal.	36			
6	Sprocket and Timing Chain, Camshaft and Bearings, and Tappets.....	37			

CHAPTER III—8-CYLINDER ENGINES

Section 1	General Information.....	47	Section 7	Sprockets and Timing Chain, Camshaft and Bearings, and Tappets.....	56
2	Engine Steady Rest.....	49	8	Flywheel, Crankshaft, and Main Bearings.....	60
3	Manifolds.....	49	9	Connecting Rods and Bearings, Pistons, Pins, and Rings.....	62
4	Cylinder Heads and Valves.....	51	10	Oil Pan, Oil Filter, and Oil Pump.....	64
5	Crankshaft Damper.....	54	11	Exhaust System.....	66
6	Cylinder Front Cover and Crankshaft Oil Seal.	55			

CHAPTER IV—IGNITION, FUEL, AND COOLING SYSTEMS

Section 1	Ignition System.....	69	Section 7	Four-Barrel Carburetor Operation, Adjustments, and Overhaul.....	95
2	Distributor Minor Repair and Adjustments....	74	8	Fuel Pumps, Vacuum Booster, and Fuel Filter .	108
3	Distributor Overhaul.....	78	9	Fuel Tanks and Lines.....	110
4	Carburetor Operation and Adjustments— Single and Dual Carburetors.....	84	10	Fans and Belts.....	111
5	Single Barrel Carburetor Overhaul.....	89	11	Water Pumps.....	112
6	Dual Carburetor Overhaul.....	92	12	Radiator, Hose, and Thermostat.....	115

Part TWO—CHASSIS

CHAPTER I—CLUTCH, TRANSMISSION, AND GEAR SHIFT LINKAGE

Section 1	Trouble Shooting.....	117	Section 5	Conventional 3-Speed Transmission.....	125
2	Clutch.....	119	6	Overdrive Transmission.....	129
3	Flywheel Housing Alignment.....	123	7	Gear Shift Linkage.....	138
4	Transmission Cleaning and Inspection.....	124			

CHAPTER II—REAR AXLES AND DRIVE LINES

Section 1	Trouble Shooting.....	141	Section 4	Integral Housing Hypoid Rear Axle.....	152
2	Cleaning and Inspection.....	142	5	Drive Lines.....	158
3	Banjo Housing Hypoid Rear Axle.....	143			

CHAPTER III—RUNNING GEAR

Section 1	Trouble Shooting.....	159	Section 6	Shock Absorbers.....	169
2	Wheel Alignment.....	161	7	Steering Gear.....	170
3	Frames.....	163	8	Steering Linkage.....	175
4	Front Suspension.....	164	9	Wheels and Tires.....	178
5	Rear Suspension.....	168	10	Hubs and Bearings.....	181

CHAPTER IV—POWER STEERING

Section 1	Trouble Shooting.....	183	Section 4	Pump and Fluid Reservoir Assembly.....	190
2	Inspection and Maintenance.....	186	5	Control Valve Assembly.....	194
3	Power Steering System Operation.....	187	6	Power Cylinder Assembly.....	200
			7	Steering Linkage.....	202

CHAPTER V—BRAKES

Section 1	Trouble Shooting.....	206	Section 5	Brake Drums.....	213
2	Adjustments.....	207	6	Vacuum Booster.....	214
3	Hydraulic System.....	208	7	Parking Brakes.....	216
4	Brake Assemblies.....	212			

Part THREE—ELECTRICAL AND ACCESSORIES

CHAPTER I—GENERATING SYSTEM AND BATTERY

	Page		Page		
Section 1	Trouble Shooting	217	Section 3	Generator Regulator	226
2	Generator	221	4	Battery	232

CHAPTER II—STARTING SYSTEM

Section 1	Trouble Shooting	235	Section 3	Starter Drive	244
2	Starter and Circuit	238			

CHAPTER III—LIGHTING SYSTEM, HORNS, AND INSTRUMENTS

Section 1	Trouble Shooting	245	Section 3	Horns	252
2	Lighting System	247	4	Instruments	253

CHAPTER IV—ACCESSORIES

Section 1	Trouble Shooting	257	Section 4	Windshield Wiper	268
2	Radio	260	5	Miscellaneous Accessories	269
3	Heater	265			

Part FOUR—BODIES

CHAPTER I—BODY CONSTRUCTION AND MAINTENANCE

Section 1	Construction Details and Sealer Application . . .	271	Section 4	Fibre Glass Repair—Thunderbird Hardtop	281
2	Body Alignment	278	5	General Body Maintenance	282
3	Quarter Panel Repair	279	6	Paint Refinishing	284

CHAPTER II—TRIM, UPHOLSTERY, AND WINDOW GLASS

Section 1	Door and Quarter Trim Panels	289	Section 4	Door Glass and Regulator Replacement	296
2	Headlining Replacement	292	5	Door Glass Adjustments	299
3	Ventilator and Division Bar	294	6	Quarter Glass	303
			7	Windshield and Rear Window	307

CHAPTER III—REMOVABLE SHEET METAL ASSEMBLIES

Section 1	Door Replacement and Alignment	313	Section 5	Grille and Hood	324
2	Door Locking Mechanism	317	6	Hood Alignment and Lock Adjustment	326
3	Luggage Compartment Door Replacement and Alignment	320	7	Thunderbird Grille and Hood	328
4	Luggage Compartment Door Locking Mechanism	323	8	Front Fenders	329

CHAPTER IV—POWER INSTALLATIONS AND SPECIAL ITEMS

Section 1	Power Windows	331	Section 4	Thunderbird Top Adjustments	347
2	Power Seats	337	5	Care of Country Squire Paneling	349
3	Convertible Top	342	6	Crown Victoria Transparent Top	350

Part FIVE—MAINTENANCE AND SPECIFICATIONS

CHAPTER I—MAINTENANCE

Section 1	Preventive Maintenance	353	Section 2	Lubrication	355
-----------	----------------------------------	-----	-----------	-----------------------	-----

CHAPTER II—SPECIFICATIONS

Section 1	Wheels and Tires	357	Section 8	Cooling	363
2	Brakes	357	9	Fuel System	363
3	Wheel Alignment and Steering	358	10	Generating System	364
4	Rear Axles	358	11	Starting System	364
5	Frame and Springs	359	12	Ignition	364
6	Engines	360	13	Fuse and Bulb Chart	365
7	Clutch and Transmission	362	14	Paint	365
			15	Tools and Equipment	366

Part ONE

POWER PLANT

Chapter

I

General Engine Overhaul, Inspection, and Repair

Section		Page
1	Trouble Shooting	5
2	Tune-Up	8
3	Engine Removal and Installation	10
4	Intake and Exhaust Manifolds	14
5	Rocker Mechanism, Cylinder Head, Valves, Valve Lash Adjustment, and Valve Timing	15
6	Timing Chain, Sprockets, and Camshaft	20
7	Flywheel, Crankshaft, and Main Bearings	22
8	Cylinder Block, Pistons, Piston Rings, and Connecting Rods and Bearings	25
9	Oil Pan and Oil Pump	29
10	Exhaust System	30

Trouble shooting; tune-up; the cleaning, inspection, and repair of component parts; and overhaul instructions are covered in this chapter.

The cleaning, inspection, repair, and overhaul instructions apply only after the parts have been removed from the engine, or in the case of a complete overhaul

after the engine has been disassembled.

To completely disassemble or assemble an engine, follow all the removal or installation instructions contained in the applicable engine chapter. If it is only desired to remove or install an individual part, refer to the applicable section.

I. TROUBLE SHOOTING

Trouble shooting is the application of a definite procedure, in a logical sequence, to locate and eliminate the cause of trouble in a particular system or unit. When trouble shooting, first look for the obvious causes of trouble, such as; an empty gas tank, a wet or cold engine, loose or disconnected wiring, or any other item that may cause a temporary defect.

The various factors that affect power plant operation are outlined in this section.

a. Engine.

Poor engine performance can be attributed to the engine or to forces on the car that tend to retard its motion.

For example, dragging brakes can cause the engine to work harder which will result in poor performance.

Engine performance depends on proper fuel distribution, correctly timed ignition, normal and uniform compression, and an unobstructed flow of exhaust gases.

Engine troubles, their causes, and remedies are discussed under appropriate headings.

(1) **ENGINE WILL NOT CRANK.** If the starter does not turn the engine over, or turns it over too slowly to start, the most probable causes are a defective battery or starter. Perform the following checks in the order listed, until the trouble is located.

(a) **CHECK THE BATTERY.** Try the horn or lights. If they do not operate properly, test the battery. Recharge or replace the battery as necessary.

(b) **CHECK THE BATTERY CABLES.** Check for loose or corroded connections at the starter, relay, battery, and ground. Clean, tighten or replace them as necessary.

(c) **CHECK THE STARTER RELAY CIRCUIT.** The relay contact surfaces seldom become so badly burned that they will prevent the starter from cranking the engine. However, other wiring may be at fault. Repair as necessary. Refer to Part **THREE**, "Electrical and Accessories."

(d) **CHECK THE STARTER OR STARTER DRIVE.** If the above components are not at fault, the trouble is probably in the starter or starter drive. If the starter is running, but not engaging the flywheel, remove the starter and make the necessary repairs to the starter drive. In rare cases, the starter drive may lock up with the flywheel. This can be corrected by loosening the starter and releasing the starter drive. If the starter does not operate, remove it and make the necessary repairs.

(2) **ENGINE CRANKS, BUT WILL NOT START.** The trouble probably lies in either the ignition system or the fuel system. The following test will determine which system is at fault:

Remove the ignition wire from one spark plug, and

insert a piece of proper sized metal rod so it protrudes from the insulator. With the ignition on and the starter turning the engine over, hold the end of the rod approximately $\frac{3}{16}$ inch from the block.

CAUTION: On Fordomatic equipped cars, make sure the selector lever is in "N."

If there is no spark, or if there is a weak spark, follow steps "a" or "b" whichever is applicable. If there is a good spark, proceed with step "c."

(a) **NO SPARK.** Follow the steps below to determine the cause, and make the necessary repairs or replacements.

(1) Pull the coil wire from the top of the distributor. Hold the wire $\frac{3}{16}$ inch from the cylinder head, and with the ignition on and the engine turning over, check for a spark.

CAUTION: On Fordomatic equipped cars, make sure the selector lever is in "N."

If a good spark is obtained, the trouble lies in either the distributor cap, rotor, or spark plug wires. Make sure these components are clean, dry, and not defective. Make repairs or replacements as necessary.

(2) If there was no spark in (1), clean the coil tower socket, or replace the high tension wire between the coil and distributor, then repeat the check. If a weak spark exists, the points are probably arcing. Test the condenser and replace it if necessary. Adjust the points. If a weak spark persists, test the coil, and replace it if necessary.

(3) If there was no spark in (2), remove the distributor cap, and see if the points are "breaking" and if an electrical spark occurs at the points. Adjust or replace the points as necessary. If there is a spark at the points; install a "jumper" between the "DIST" terminal of the coil and the distributor, then check for a spark at the points. If there is a spark, replace the coil to distributor primary wire. If there is no spark, crank the engine until the points are closed, then install a "jumper" on one of the primary coil terminals and check for a spark at the other terminal. Replace the coil if there is now a spark. If there is no spark, install a "jumper" between the battery and the battery terminal of the coil, then check for a spark at the points. If a spark exists, the ignition switch or switch to coil wiring is defective and must be repaired or replaced.

(b) **WEAK SPARK.** Perform the following checks in the order listed:

(1) The battery may be weak. Test the battery, then charge, or replace it if necessary.

(2) Remove the distributor cap, and adjust, clean, or replace the points as necessary. Severely pitted points usually indicate that the voltage regulator is improperly set or the condenser is faulty.

(3) Check the condition of the rotor, distributor cap, and plug wires. The wires must be clean, dry, and fully

seated in the terminals. Replace any damaged or corroded wires.

(4) If the weak spark persists, test the coil, and replace it if necessary.

(c) **GOOD SPARK.** If there is a good spark, perform the following fuel system checks in the order given.

(1) Check the fuel supply at the fuel tank.

(2) Check to see if fuel is reaching the carburetor. Remove the air cleaner, and look down the carburetor throat while working the throttle by hand several times. Each time the throttle is actuated, fuel should spurt from the accelerator pump discharge nozzle. If there is fuel at this point, the engine is probably flooded or there is water in the fuel system. If no fuel is observed at this point, disconnect the carburetor inlet line at the carburetor. Using a suitable container to catch the fuel, crank the engine to see if fuel is reaching the inlet fitting. If fuel is reaching the inlet fitting, the trouble is in the carburetor. Repair the carburetor as necessary. If no fuel is reaching the inlet fitting, the trouble is in the fuel pump or the fuel pump inlet line is clogged.

NOTE: Check the flexible fuel pump inlet line for a collapsed condition.

Remove the fuel tank filler cap, then disconnect the fuel pump inlet line at the pump. Blow air into the line to remove any obstructions. Connect the line and try to start the engine. If the engine does not start, check the fuel pump pressure, then repair or replace the pump as necessary.

(3) **ENGINE STARTS BUT FAILS TO KEEP RUNNING.** Check the fuel system first. The ignition system sometimes can cause trouble, but it is usually after the engine has run for some time and is at operating temperature.

(a) Check the fuel supply at the tank.

(b) Try to start the engine. If the engine will operate with constant foot throttle, adjust the idle speed and check the choke adjustment.

If it will not operate with constant foot throttle, check the fuel system as outlined in (2) (c).

(c) If the fuel system is operating correctly and the engine still stalls, it may be due to the coil or condenser breaking down under operating temperature. Check these components, and replace them as necessary.

(4) **ENGINE CONTINUALLY MISSES AT IDLE.** When the engine continually misses on the same cylinders, the fault generally lies in the ignition system.

(a) Isolate the miss by pulling one spark plug cable at a time from the plugs. Remove the plugs, then clean, inspect, and adjust them. Replace those that are badly fouled or burned.

(b) Check the spark plug wires for signs of deterioration and corrosion and replace them as necessary.

(c) Remove the distributor cap and rotor, then clean, inspect, and replace them as necessary.

(d) If the above steps do not correct the condition, check the compression to determine if it is satisfactory and check the intake manifold passages for obstructions.

(5) **ENGINE MISSES ERRATICALLY AT IDLE.** A miss of this type may be caused by a combination of things. Check the following in sequence:

(a) Carburetor, including choke operation, idle mixture setting, and fuel level.

(b) The ignition system, starting with the spark plugs. Make the necessary repairs.

(c) The vacuum lines and fittings for leaks. Make any necessary repairs.

(d) Valve operation. Perform a compression test if the miss persists. Repair the engine as necessary.

(6) **ENGINE MISFIRES OR HESITATES ON ACCELERATION.** This malfunction is usually a combination of faults in the ignition and fuel system, but also can be caused by the exhaust system. Check the following in sequence.

(a) Check the operation of the exhaust gas control valve. If it is sticking, free it up or replace it as necessary.

(b) Check the paint on the intake manifold heat riser passage. If the paint is not burned off, the passage may be obstructed preventing the carburetor from properly vaporizing the fuel.

(c) Remove the spark plugs. Inspect, clean, and adjust the gap. Replace any plugs that are defective or lead-fouled.

(d) Remove the distributor cap, and check the point gap, distributor shaft clearance, condition of the cam lobes, and the points. Make the necessary repairs or replacements. Check the high tension wiring for signs of deterioration, and make replacements or repairs as necessary.

(e) Check the coil and condenser. Replace them if they are defective.

(f) Check the fuel pump pressure and adjust the carburetor fuel level. Check the accelerator pump action and linkage.

(g) If the problem still persists, perform a compression test, and check the valve lash. Check the valve spring rates and assembled height. Make repairs or replacements as necessary.

(7) **ENGINE DOES NOT DEVELOP FULL POWER.** Lack of power is usually caused by poor compression. However, some preliminary checks should be made. Make sure the throttle opens all the way, and the choke remains open. After preliminary checks are made, perform the following operations if the trouble has not been located:

(a) Check the compression. This will indicate whether the internal components are operating properly.

(b) If the compression checks within limits, check the ignition system, including initial timing and distributor operation.

(c) If the compression and the ignition system are satisfactory, check the fuel system, including carburetion and fuel pump pressure.

(d) If the problem still exists, a check of mechanical components must be made. Check the valve lash, cam lobe lift, and valve timing. Make the necessary repairs.

b. Fuel System.

The fuel system consists of the fuel tank, fuel pump, carburetor, and connecting lines. Dirt and other foreign material are a major source of fuel system problems. Keep all components as clean as possible.

(1) **EXCESSIVE FUEL CONSUMPTION.** Faulty carburetion is usually responsible for excessive fuel consumption. However, the following preliminary checks should be made:

Check for fuel leaks in the system. Check choke operation and adjustment, and make certain the accelerator linkage is free. Check to see if the brakes are dragging. Adjust the carburetor.

(a) Verify the complaint with test equipment installed in the car. Show the customer how improper operation of the car will affect fuel consumption.

(b) If the test shows fuel consumption to be excessive, rebuild the carburetor. Since poor carburetion is usually a combination of internal malfunctions, it is usually not advisable to try to repair only one system in the carburetor. Time will be saved by a complete carburetor overhaul.

(2) **CARBURETOR FLOODS.** Make a visual inspection of the carburetor for leaking gaskets or casting defects. Tap the carburetor bowl. If the flooding stops, the inlet needle was held open by foreign material. If the flooding persists, follow the steps below:

(a) Remove the air cleaner and check the choke operation.

(b) Check the fuel level, the condition of the carburetor float, and the fuel inlet needle and seat. Replace any defective parts.

(c) Check fuel pump pressure. If the pressure is excessive, the pump was forcing fuel past the inlet needle and the pump should be rebuilt or replaced.

c. Cooling System.

The cooling system is thermostatically controlled to regulate engine operating temperature and provide for a short engine warm-up period.

(1) **ENGINE OVERHEATS.** Usually, engine overheating is the result of insufficient coolant supply. Check the coolant level first. Make certain that the cause of trouble is not anti-freeze evaporation.

(a) If the supply is low, check for leaks in the cooling system, then make the necessary repairs.

(b) Check the water pump belt for proper tension and adjust it if it is loose.

(c) Inspect the radiator fins for obstructions (bugs, dirt, etc.). Clean it if it is clogged.

(d) Using a thermometer in the radiator, check the gauge reading for accuracy.

NOTE: Inaccurate readings are sometimes caused by insufficient clearance between the head casting and the temperature sending unit element. Make repairs or replacements as necessary.

(e) Check the thermostat for proper operation and heat range. If it is defective or of the wrong heat range, replace it. Make sure the thermostat is correctly installed.

(f) Check the ignition timing and adjust it if necessary.

(g) Check the radiator for proper flow. Flush it if necessary.

(h) Remove the water pump and check for a defective impeller or a water passage obstruction. Make repairs or replacements as necessary.

(i) Check the cylinder head(s) for water passage obstructions. Clean out the passages or replace the head(s) if necessary.

(j) Check the cylinder block for water passage obstructions. Clean out the passages or replace the block if necessary.

(2) ENGINE FAILS TO REACH NORMAL OPERATING TEMPERATURE. Generally this is caused by the thermostat sticking or being of the wrong heat range. Check the thermostat first. If the engine still does not reach operating temperature, check the gauge and sending unit with a thermometer installed in the radiator. Replace any defective parts.

2. TUNE-UP

Regular maintenance and inspection services are necessary for proper car operation. In addition, to maintain satisfactory performance, a periodic engine tune-up should be made.

A reliable type of engine test equipment should be used to perform the tests. As the checks and tests are made, make a visual inspection of the wiring, vacuum hoses, cooling system hoses, heater hoses, etc.

a. Minor Tune-Up.

Perform the following operations in the order given.

(1) INSPECT IGNITION WIRES, BATTERY CABLES, AND CHECK THE CONDITION OF THE BATTERY. Inspect all ignition wires for worn or damaged insulation. Make sure the wires are firmly seated in the distributor cap and that the terminals and terminal sockets are free from corrosion.

Inspect the battery case for cracks and leaks. Make a battery capacity test. If unsatisfactory, make a battery charge test. If the charge is low, recharge the battery. Inspect the battery cable connections for corrosion, and clean them if necessary. Brush the cable connectors with grease to retard further corrosion, then tighten the connectors securely.

(2) TEST CYLINDER COMPRESSION. Be sure the battery is good. Operate the engine until normal operating temperature is reached. Turn the ignition switch off. Remove all spark plugs.

Set the throttle in the wide open position and be sure the choke is wide open. Install a compression gauge in number 1 cylinder. Crank the engine until the gauge registers a maximum reading and record the reading. Note the number of compression strokes required to obtain this reading. Repeat the test on each cylinder, cranking the engine the same number of strokes as was required to obtain a maximum reading on number 1 cylinder.

A variation of ± 10 pounds from specified pressure is satisfactory. However, the compression of all cylinders should be uniform within 10 pounds.

A reading of more than 10 pounds above normal indicates carbon or lead deposits in the cylinder.

A reading of more than 10 pounds below normal indicates leakage at the head gasket, rings, or valves.

A low even compression in two adjacent cylinders indicates a head gasket leak. This should be checked before condemning the rings or valves.

To determine whether the rings or the valves are at fault, put a tablespoon of heavy oil on the piston, and repeat the compression test. The oil will temporarily seal leakage past the rings. If the same reading is obtained, the rings are satisfactory, but the valves are leaking. If the compression has increased 10 pounds or more over the original reading, it indicates there is leakage past the rings.

During a compression test, if the pressure fails to climb steadily and remains the same during the first two successive strokes, but climbs higher on the succeeding strokes, or fails to climb during the entire test, it indicates a sticky or stuck valve.

(3) CLEAN, ADJUST, AND INSTALL THE SPARK PLUGS. Sandblast the spark plugs, wipe the porcelain clean, file the electrode tips flat, and adjust the spark gap. Test the plugs in an approved spark plug tester. Inspect the plugs for broken or chipped porcelain and badly burned electrodes. Replace all defective plugs. Install the spark plugs and tighten them to the specified torque.

(4) CHECK THE DISTRIBUTOR. Remove the distributor cap and rotor. Inspect the breaker points for pitting and burning. Replace defective points. Clean and install the distributor cap and rotor.

(5) CHECK IGNITION TIMING. Disconnect the dis-

tributor vacuum line. Operate the engine at idle speed. Check the timing with a timing light and make the necessary adjustments. Connect the distributor vacuum line.

(6) **CHECK MANIFOLD VACUUM AND ADJUST CARBURETOR IDLE.** Check the manifold vacuum at the specified idle speed.

If the vacuum is lower than specified, check for leakage at the vacuum lines and intake manifold. Check the carburetor idle adjustment.

If the vacuum is still below normal or is erratic, it is an indication of bad rings, sticky valves, weak valve springs, or a head gasket leak.

Set the engine idle speed and the carburetor idle fuel adjustment as outlined in Chapter IV.

(7) **CLEAN THE AIR CLEANER AND THE FUEL FILTER.** Clean the air cleaner, and oil the element. If the air cleaner is the oil bath-type, fill to the indicated level with engine oil of the specified viscosity.

On passenger cars, remove and clean the fuel pump bowl. Install a new filter element.

On Thunderbirds, clean the fuel line filter. Install a new filter element.

(8) **CHECK THE DEFLECTION OF THE DRIVE BELTS.** Check the deflection of all drive belts (fan, air conditioning, and power steering). Make the necessary adjustments.

b. Major Tune-Up.

Perform the following operations in the order given.

(1) **BATTERY.** Remove the cables from the battery. Clean the battery terminals and cable connectors. Inspect the battery case for cracks and leaks. Make a battery capacity test. If unsatisfactory, make a battery charge test. If the charge is low, recharge the battery. Replace deteriorated connectors and cables that have worn insulation. Brush the cable connectors with grease to retard further corrosion. Connect the cables to the battery.

(2) **CHECK THE GENERATOR AND REGULATOR.** Follow the procedures outlined in Part THREE, "Electrical and Accessories."

(3) **TEST SPARK INTENSITY.** Determine if the spark from each plug wire will jump a $\frac{3}{16}$ inch gap, as follows:

Remove one spark plug wire, and install a terminal adapter in the wire terminal. Hold the end of the adapter approximately $\frac{3}{16}$ inch from the cylinder head. Run the engine at idle speed. The spark should jump the gap regularly. Repeat the test on each lead.

If the spark is unsatisfactory at all spark plugs, trouble exists in the coil, condenser, rotor or cap, internally in the distributor, or in the external primary circuit.

If the spark is unsatisfactory at some, but not all of the spark plug wires, the trouble is in the wire itself, the wire is not seated in the housing socket, or the distributor cap is corroded.

(4) **TEST CYLINDER COMPRESSION.** Follow the procedure under "a. Minor Tune-Up."

(5) **CLEAN, ADJUST, AND INSTALL SPARK PLUGS.** Sandblast the spark plugs, wipe the porcelain clean, file the electrode tips flat, and adjust the gap. Test the plugs in an approved tester. Inspect the plugs for broken or chipped porcelain and badly burned electrodes. Replace all defective plugs. Install the plugs and tighten them to the specified torque.

(6) **CHECK MANIFOLD BOLT TORQUE.** Tighten the intake and exhaust manifold bolts and nuts to 23-28 foot-pounds torque.

(7) **TEST COIL AND CONDENSER.** If the spark intensity (3) is satisfactory, it will not be necessary to test the coil and condenser. However, if the spark is not satisfactory, test these parts on a test unit to determine which one is defective. Follow the instructions of the test unit manufacturer.

(8) **INSPECT BREAKER POINTS AND TEST THE DISTRIBUTOR.** Inspect the distributor points for pits, excessive metal transfer, and burned spots.

Test the vacuum advance and make adjustments, repairs, or replacements as required. Set the point gap to specifications. After setting the gap, check the point dwell. If the dwell angle is not to specifications, the distributor cam is worn or the point assembly is defective. Replace all defective parts. Lubricate the distributor cam lightly with distributor cam lubricant.

(9) **CLEAN AND INSPECT THE DISTRIBUTOR CAP.** Inspect the cap for cracks or other damage. Remove all corrosion from the terminal housing sockets.

(10) **CHECK IGNITION TIMING.** Disconnect the vacuum line between the distributor and carburetor and operate the engine at idle speed. Check the timing with a timing light and make the necessary adjustments. Connect the distributor vacuum line after completing the adjustment and check ignition advance as the engine is accelerated.

(11) **CHECK AND ADJUST VALVE LASH.** Check and adjust the valve lash after the engine is thoroughly warmed up.

(12) **TEST MANIFOLD VACUUM.** Check the manifold vacuum at the specified idle speed.

If the vacuum is lower than specified, check for leakage at the vacuum lines and intake manifold. Check the carburetor idle adjustment.

If the vacuum is still below normal or is erratic, it is an indication of bad rings, sticky valves, weak valve springs, or a leaking head gasket. If this condition exists, it should be reported to the customer.

(13) **TEST FUEL PUMP PRESSURE AND CAPACITY.** The static pressure should be 3.5-5.5 p.s.i. at 500 r.p.m. The capacity should be 1 pint in 30 seconds at 500 r.p.m.

(14) **TEST BOOSTER PUMP VACUUM.** The booster pump vacuum should be 10.0 inches of mercury at 500 r.p.m. The vacuum should not drop rapidly when the engine is stopped.

(15) **INSPECT AND CLEAN THE FUEL FILTER.** On passenger cars, remove and clean the fuel pump bowl. Install a new filter element.

On Thunderbirds, clean the fuel line filter. Install a new filter element.

(16) **CLEAN THE CARBURETOR.** Disassemble and clean the carburetor. Set the fuel level, and check the accelerator pump operation.

(17) **CLEAN THE AIR CLEANER.** Clean the air cleaner and the element. If the air cleaner is the oil bath-type, fill to the indicated level with engine oil of

the specified viscosity.

(18) **ADJUST CARBURETOR IDLE.** Set the engine idle speed and the carburetor idle fuel adjustment as outlined in Chapter IV.

(19) **EXHAUST ANALYSIS.** On dual exhaust equipped cars, connect the analyzer tube to the left muffler outlet pipe.

Inasmuch as there are several types of analyzers, follow the instructions of the manufacturer.

(20) **CHECK THE DEFLECTION OF THE DRIVE BELTS.** Check the deflection of all drive belts (fan, air conditioning, and power steering). Make the necessary adjustments.

(21) **ROAD TEST.** Road test the car as a final check on the work performed. Also, notice the performance of the transmission, axle, brakes, and any optional accessories. Recommend any additional service required when the car is delivered to the owner.

3. ENGINE REMOVAL AND INSTALLATION

Separate procedures are given for the conventional passenger car and the Thunderbird.

a. Conventional Passenger Car.

The following procedures apply to all conventional passenger cars. Differences in the procedures peculiar to cars equipped with an 8 or 6-cylinder engine are noted when they exist.

The procedures given are for the engine only, without the transmission attached. Engine compartment tolerances make it impractical to remove or install the engine with the transmission attached.

(1) **REMOVAL.** If the car is equipped with a standard or overdrive transmission, follow steps (a) and (c). If the car is equipped with Fordomatic, follow steps (b) and (c).

(a) **STEPS PECULIAR TO A STANDARD OR OVERDRIVE TRANSMISSION.** Disconnect the clutch release spring. Remove the screws retaining the equalizer bar support to the flywheel housing, then remove the support and bushing. Disconnect the accelerator linkage at the manifold bell crank. Remove the two flywheel housing upper bolts. Remove the flywheel housing cover, support the transmission with a jack, then remove the remaining flywheel housing bolts.

(b) **STEPS PECULIAR TO FORDOMATIC.** Disconnect the transmission throttle linkage at the cross shaft, and tie the linkage to the dash panel. Remove the idler arm bracket. Fold back the floor mat, remove the two rubber plugs, then remove the two converter housing to engine upper bolts. Jack up the front of the car and position safety stands. Support the transmission with a jack, then remove the remaining converter housing to engine bolts.

Remove the converter housing lower access cover, then turn the flywheel till the flywheel drive plate is in position to remove the three bolts. Turn the flywheel 180°, then remove the other three bolts.

CAUTION: *After the bolts are removed from the converter drive plate, turn the drive plate 90° so the flex plates will not catch on the converter housing when the engine is removed.*

Drain the transmission. Remove the bracket that secures the transmission oil level indicator tube to the engine. Disconnect the tube at the transmission oil pan, then remove the tube assembly. Remove the transmission control linkage splash shield from the cylinder block, then remove the oil filter.

(c) **ENGINE REMOVAL.** Remove the hood. Drain the cooling system and the crankcase. Remove the heater hoses. Remove the heater inlet duct and the heater blower motor.

Remove the radiator upper and lower hoses, then remove the radiator. Remove the fan. Disconnect the battery ground cable at the cylinder block, and the flex fuel line at the fuel pump.

Disconnect the windshield wiper vacuum hose, temperature sending unit wire, and the oil pressure sending unit wire. Disconnect the primary wire at the coil. Remove the starter cable at the starter, then remove the starter. Disconnect the ground cable from the rear of the engine. Remove the air cleaner, then tape the air horn closed. Disconnect the choke cable at the carburetor. Disconnect the accelerator linkage.

Disconnect the muffler inlet pipes at the exhaust manifold.

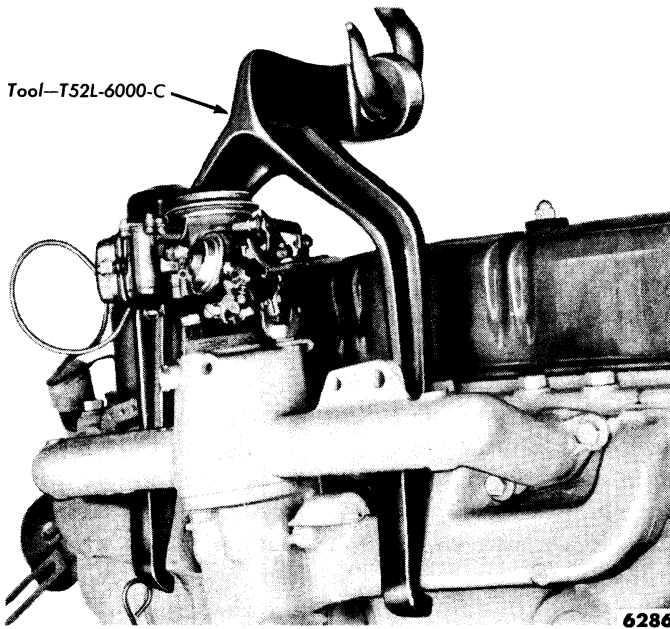

Fig. 1—Lifting Hook—6-Cylinder Engine

Attach the engine lifting hook(s) (fig. 1 or 2). Remove the right and left front splash aprons.

On 8-cylinder engines, remove the retainer and lower insulator from the engine front steady rest.

On 6-cylinder engines, loosen the two engine front steady rest to spacer bolts. Raise the car and position safety stands.

On 8-cylinder engines, remove the engine left insulator. Remove the cap screws from the engine right insulator at the engine.

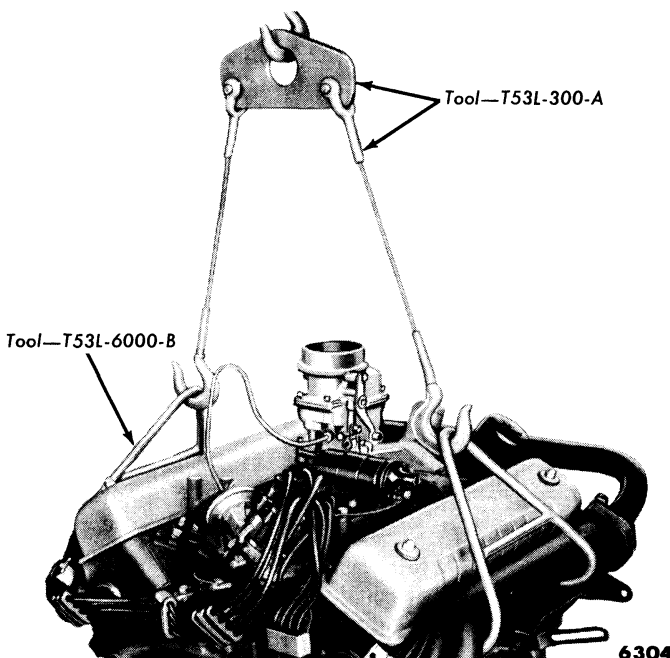

Fig. 2—Lifting Hooks and Sling—8-Cylinder Engine

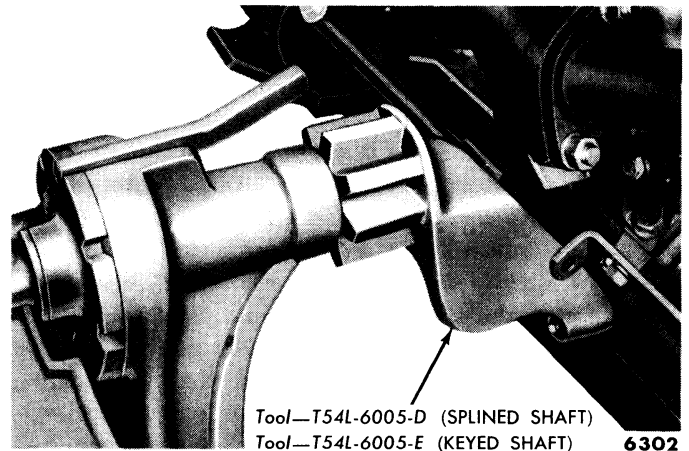

Fig. 3—Engine Mount—8-Cylinder Engine

On 6-cylinder engines, remove the left insulator to bracket bolts at the insulator, and the right bracket bolts at the engine.

Raise the engine slightly, then carefully pull it from the transmission. Carefully lift the engine out of the engine compartment. Do not let the engine swing against the grille.

Install the engine on a work stand (fig. 3 or 4).

(2) **INSTALLATION.** If the car is equipped with a standard or overdrive transmission, follow steps (a), (b), and (d). If the car is equipped with Fordomatic, follow steps (a), (c), and (d).

(a) **ENGINE INSTALLATION.** Install the appropriate engine lifting hook, then remove the engine from the work stand.

CAUTION: On Fordomatic equipped cars, make sure the flywheel drive plate is turned so the flex plate will not catch on the converter housing.

Lower the engine carefully into the engine compartment.

On 8-cylinder engines, lower the engine until the oil pump to oil pan line clears the engine left support.

Start the transmission main drive gear into the clutch

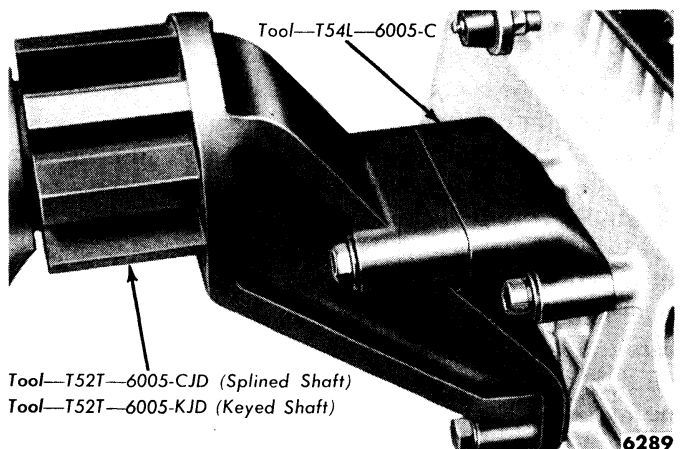

Fig. 4—Engine Mount Adapter—6-Cylinder Engine

disc. On Fordomatic units, start the converter pilot into the crankshaft.

NOTE: *On standard or overdrive units, it may be necessary to adjust the position of the transmission with relation to the engine if the transmission input shaft will not enter the clutch disc. If the engine "hangs up" after the shaft enters, turn the crankshaft slowly (with the transmission in gear) until the shaft splines mesh with the clutch disc splines.*

Make sure the studs on the manifolds of both the 6 and 8-cylinder engines are aligned with the holes in the muffler inlet pipe(s) and the dowels in the block engage the holes in the clutch housing (on Fordomatic units the block dowels must engage the holes on the converter housing).

NOTE: *Level the engine crosswise in relation to the frame before installing the mounting bolts or the steady rest.*

On the 6-cylinder engine, install the left insulator to bracket lockwashers and bolts and the right bracket to engine lockwashers and bolts. Tighten the insulator to bracket bolts to 45-50 foot-pounds torque. Tighten the engine front steady rest to spacer bolts to 30-35 foot-pounds torque.

On the 8-cylinder engine, align the holes in the engine left support insulator with the mounting holes in the block, then install the insulator to engine bolts and the frame to insulator lockwashers and nuts. Install the right insulator to engine lockwashers and bolts. Tighten the insulator to engine bolts to 45-50 foot-pounds torque and the frame to insulator nuts to 50-60 foot-pounds torque. Install the engine front steady rest lower insulator and retainer. Tighten the retainer bolt to 23-28 foot-pounds torque. Install the right and left front splash aprons.

Connect the manifold(s) to the muffler inlet pipe(s). Install the starter, then connect the starter cable (except Fordomatic). Connect the ground cable to the rear of the engine, the temperature sending unit and oil pressure sending unit wires, the generator wires, and the ignition switch wire to the coil. Connect the ignition switch wire to the engine clips. Connect the accelerator linkage and the choke wire (6-cylinder engine).

Connect the windshield wiper line and the fuel pump vacuum line. Connect the fuel pump flexible line. Install the fan assembly, then adjust the fan belt.

Install the radiator and connect the radiator hoses. Connect the battery ground cable to the engine. Remove the tape from the carburetor air horn and install the air cleaner. Install the heater blower motor and the heater inlet duct, then connect the heater hoses.

Install the hood. Fill the cooling system and the crankcase.

(b) **CONNECT STANDARD OR OVERDRIVE TRANSMISSION.** Install the bushings in the equalizer bar support,

then install the support on the flywheel housing. Install the transmission to flywheel housing bolts, and tighten them to 40-50 foot-pounds torque. Install the flywheel housing cover. Connect the clutch release spring.

Remove the jack supporting the transmission. Check the clutch pedal free travel ($1\frac{1}{8}$ - $1\frac{3}{8}$ inches) and adjust it if necessary.

(c) **CONNECT FORDOMATIC TRANSMISSION.** Install the two converter housing to engine lower bolts, and tighten them to 40-45 foot-pounds torque.

NOTE: *Tighten the bolts slowly and evenly to avoid binding on the dowel pins.*

Install the two converter housing to engine upper bolts, and tighten them to 40-45 foot-pounds torque. Install the floor pan plugs. Align the flywheel and drive plate holes with the converter, then install the six bolts, and tighten them to 25-28 foot-pounds torque.

Install the starter, and tighten the bolts to 15-20 foot-pounds torque. Install the transmission oil level indicator tube assembly. Install the idler arm and bracket. Tighten the idler arm bracket nuts to 28-43 foot-pounds torque. Install the converter housing lower access covers.

Install and connect the throttle linkage and make the necessary linkage adjustments. Remove the jack supporting the transmission. Fill the transmission with Automatic Transmission Fluid—Type A, following the recommended procedure.

(d) **CHECK ENGINE FOR OIL OR COOLANT LEAKS.** Run the engine at fast idle and check all gaskets and hose connections for leaks.

b. Thunderbird.

On Fordomatic equipped Thunderbirds, the engine may be removed with or without the transmission attached.

(1) **REMOVAL.** To remove the engine from a Thunderbird equipped with a standard or overdrive transmission, follow steps (a) and (c). To remove the engine from a Thunderbird equipped with Fordomatic, follow steps (b) and (c). To remove the engine and Fordomatic as an assembly, follow steps (c) and (d).

(a) **STEPS PECULIAR TO A STANDARD OR OVERDRIVE TRANSMISSION.** Disconnect the clutch release spring. Remove the screws retaining the equalizer bar support to the flywheel housing, then remove the support and bushing. Remove the two flywheel housing upper bolts. Remove the flywheel housing cover, support the transmission with a jack, then remove the remaining flywheel housing bolts.

(b) **STEPS PECULIAR TO FORDOMATIC.** Disconnect the transmission throttle linkage at the cross shaft, and tie the linkage to the dash panel. Remove the idler arm bracket.

Jack up the front of the car and position safety stands.

Support the transmission with a jack, then remove the converter housing to engine bolts. Remove the converter housing lower access cover, then turn the flywheel till the flywheel drive plate is in position so the three bolts can be removed. Turn the flywheel 180°, then remove the other three bolts.

CAUTION: *After the bolts are removed from the converter drive plate, turn the drive plate 90° so the flex plates will not catch on the converter housing when the engine is removed.*

Drain the transmission. Remove the bracket that secures the transmission oil level indicator tube to the engine. Disconnect the tube at the transmission oil pan and remove the tube assembly. Remove the transmission control linkage splash shield.

(c) **ENGINE REMOVAL.** Remove the hood. Drain the cooling system and the crankcase. Remove the fan, then remove the radiator and shroud as an assembly. Remove the air cleaner. Disconnect the engine ground wire at the dash panel. Disconnect the battery ground cable at the engine and the battery to starter relay cable at the battery. Disconnect the vacuum pump line, and the fuel inlet at the fuel pump. Disconnect the starter cable at the starter solenoid, then remove the cable clamp at the dash panel. Disconnect the ignition switch to coil wire at the coil. Disconnect the two heater hoses. Remove the generator wires. Remove the wires from the oil pressure sending unit and the temperature sending unit. Remove the heater blower assembly. Disconnect the tachometer cable. Disconnect the accelerator rod, then disconnect the link bracket at the block (this bracket also serves as the ignition cable bracket).

Raise the car and position safety stands. Disconnect the exhaust pipes at the exhaust manifolds. Remove the engine front mount bolt, nut, and lower insulator. Remove the engine right and left steady rest bracket bolts at the engine, then turn the brackets to one side so the engine will clear them upon removal.

Remove the safety stands and lower the car. Install the engine lifting hooks (fig. 2). Raise the engine slightly, then carefully pull the engine from the transmission. Carefully lift the engine out of the engine compartment.

Install the engine on a work stand (fig. 3).

(d) **STEPS PECULIAR TO REMOVING THE ENGINE AND FORDOMATIC AS AN ASSEMBLY.** While the car is raised in step (c), perform the following additional operations:

Drain the transmission. Disconnect the shift control linkage at the transmission and the throttle control rod. Disconnect the speedometer cable. Remove the drive shaft, and plug the transmission with an extension housing cap. Remove the converter air duct assembly. Remove the bracket that secures the transmission oil level indicator tube to the engine. Disconnect the tube at the

transmission oil pan, then remove the tube assembly. Remove the engine rear mount bolt, raise the transmission, then remove the cross member that serves as the engine rear mount.

Remove the transmission jack and lower the car. Install the engine lifting hooks. Raise the engine slightly, then carefully pull the engine and transmission forward. Carefully lift the engine and transmission from the engine compartment.

(2) **INSTALLATION.** To install the engine in a Thunderbird equipped with a standard or overdrive transmission, follow steps (a), (b), (e), and (f). To install the engine only in a Fordomatic equipped Thunderbird, follow steps (a), (c), (e), and (f). To install the engine and Fordomatic as an assembly, follow steps (a), (d), (e), and (f).

(a) **ENGINE INSTALLATION.** Install the engine lifting hooks, then remove the engine from the work stand.

CAUTION: *On Fordomatic equipped cars, make sure the flywheel drive plate is turned so the flex plates will not catch on the converter housing.*

Lower the engine carefully into the engine compartment.

Start the transmission main drive gear into the clutch disc. On Fordomatic units, start the converter pilot into the crankshaft.

NOTE: *On standard or overdrive units, it may be necessary to adjust the position of the transmission with relation to the engine, if the input shaft will not enter the clutch disc. If the engine "hangs up" after the shaft enters, turn the crankshaft slowly (with the transmission in gear) until the shaft splines mesh with the clutch disc splines.*

Make sure the studs on the manifolds are aligned with the holes in the muffler inlet pipes, and the dowels in the block engage the holes in the clutch housing (on Fordomatic units the block dowels must engage the holes on the converter housing).

Raise the car and position safety stands. Install the engine front support lower insulator, bolt, lockwasher, and nut. Tighten the insulator mounting nut to 85-95 foot-pounds torque. Install the engine right and left steady rest bracket bolts, and tighten the bolts to 45-50 foot-pounds torque.

NOTE: *If the rod assembly adjustment of either steady rest was disturbed during engine removal, adjust the rod as outlined in step (e).*

Connect the exhaust pipes to the exhaust manifolds. Remove the safety stands and lower the car.

Connect the accelerator rod, then connect the accelerator link bracket to the block. Connect the tachometer cable. Install the heater blower assembly. Install the oil pressure sending unit and the temperature sending unit wires. Connect the generator wires. Connect the two heater hoses. Connect the ignition switch to coil

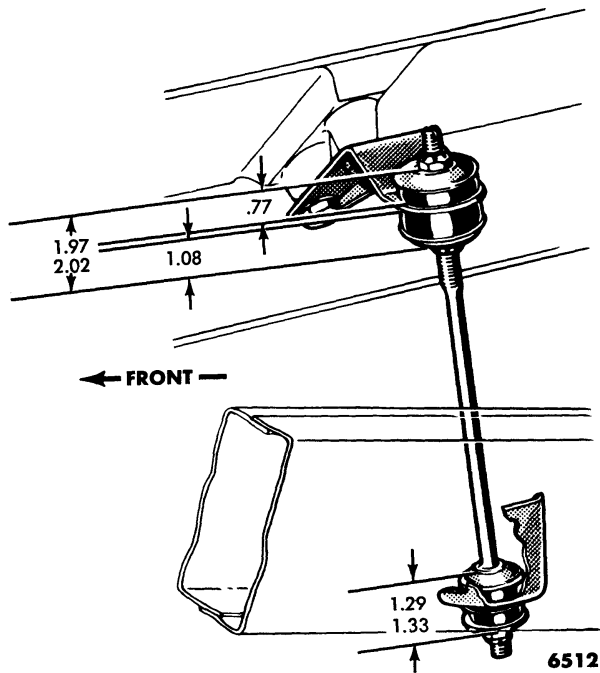

Fig. 5—Steady Rest Adjustment—Thunderbird

wire. Install the starter cable clamp on the dash panel, and connect the starter cable to the starter. Connect the windshield wiper line and the flexible fuel line. Connect the battery ground cable and the starter solenoid cable. Connect the engine ground wire. Install the air cleaner. Install the radiator and shroud, then install the fan. Install the hood. Fill the cooling system. Fill the crankcase with the correct quantity and grade of engine oil.

(b) **CONNECT STANDARD OR OVERDRIVE TRANSMISSION.** Install the bushings in the equalizer bar support, then install the support on the flywheel housing. Install the transmission to flywheel housing bolts, and tighten them to 40-50 foot-pounds torque. Install the flywheel housing cover. Connect the clutch release spring.

Remove the jack supporting the transmission. Check the clutch pedal free travel ($1\frac{1}{8}$ - $1\frac{3}{8}$ inches). Adjust the free play, if necessary.

(c) **CONNECT FORDOMATIC TRANSMISSION.** Install the two converter housing to engine lower bolts, and tighten them to 40-45 foot-pounds torque.

NOTE: Tighten the bolts slowly and evenly to avoid binding on the dowel pins.

Install the converter housing to engine bolts and tighten them to 40-45 foot-pounds torque. Align the flywheel and drive plate holes with the converter, install the six bolts, and tighten them to 25-28 foot-pounds torque.

Install the starter and tighten the bolts to 15-20 foot-pounds torque. Install the transmission oil filler tube assembly. Install the idler arm and bracket. Tighten the idler arm bracket nuts to 28-43 foot-pounds torque. Install the converter housing lower access covers.

Install and connect the throttle linkage, and make the necessary linkage adjustments. Remove the jack supporting the transmission. Fill the transmission with Automatic Transmission Fluid-Type A, following the recommended procedure.

(d) **INSTALL THE ENGINE AND FORDOMATIC AS AN ASSEMBLY.** While the car is raised in step (a), perform the following additional operations:

Jack up the transmission. Install the engine rear mount. Lower the transmission, then install the engine rear mount bolt. Install the converter air duct assembly. Install the transmission oil level indicator tube assembly. Remove the extension housing cap from the transmission, and install the drive shaft. Connect the speedometer cable. Connect the shift control linkage and the throttle control rod. Fill the transmission with Automatic Transmission Fluid-Type A, following the recommended procedure.

(e) **ENGINE STEADY REST ADJUSTMENT.** If the engine steady rests are not properly adjusted, the engine will be tilted and excessive engine vibration may result. It is good practice, therefore, to check the adjustment of the rod assemblies, at each engine installation. The dimensions are illustrated in fig. 5. If the rods are out of adjustment follow the procedure below:

With the engine steady rest support brackets in place and properly tightened (at the engine and chassis), loosen the rod lower and upper nuts on both steady rests. Let the engine seek its own level position. Turn the rod assembly lower nut, washer, and insulator of each steady rest up against the lower (chassis) support bracket. Tighten the lower nut to the dimension shown in fig. 5.

Turn the lower nut, washer, and insulator at the top of each rod assembly up against the engine support bracket. Tighten the nut to the dimension shown in fig. 5. Turn the upper nut, washer, and insulator at the top of the rod assembly down against the engine support bracket. Tighten the nut to the dimension shown in fig. 5. Check the adjustment of the top portion of the rod assembly by measuring the over-all dimension as indicated in fig. 5.

(f) **CHECK THE ENGINE FOR OIL OR COOLANT LEAKS.** Run the engine at fast idle and check all gaskets and hose connections for leaks.

4. INTAKE AND EXHAUST MANIFOLDS

a. Cleaning and Inspection.

Wash grease, oil, and dirt from the outside of the

exhaust manifolds. Clean the mating surfaces and check

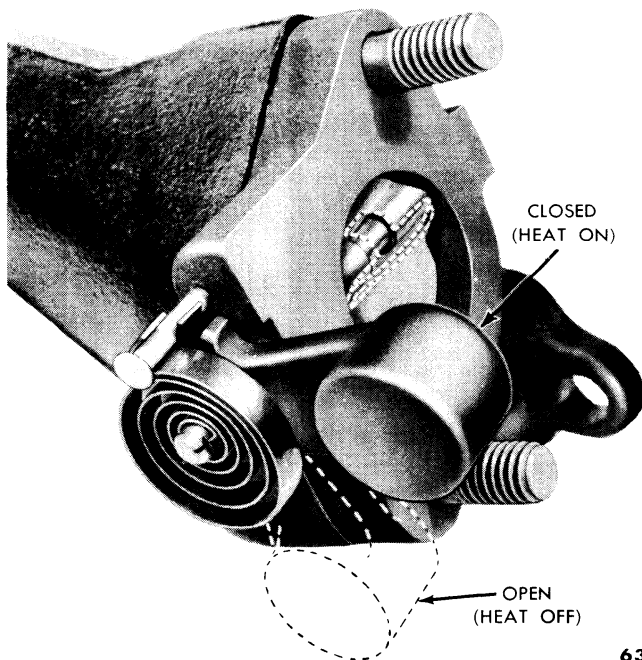

6337

Fig. 6—Exhaust Control Valve—Single Exhaust System

them for damage. Repair or replace the manifolds as necessary.

On the intake manifold, check the fuel-air and the heat riser passages for foreign material. Inspect the surfaces for cracks or other visible defects. Repair or replace the manifolds as necessary.

CAUTION: Remove all filings and foreign matter that may have entered the manifolds as a result of repair work.

b. Exhaust Gas Control Valve.

Check the valve spring to make sure it is hooked on the stop pin. The spring stop is at the top of the valve housing when the valve is properly installed. The action of the valves is illustrated in figs. 6, 7, and 8.

Check to make sure the spring holds the valve closed when the engine is cold. Actuate the counterweight by hand to make sure it moves freely through approximately 90° of rotation without binding.

The valve is closed when the engine is at normal operating temperature and running at idle speed. How-

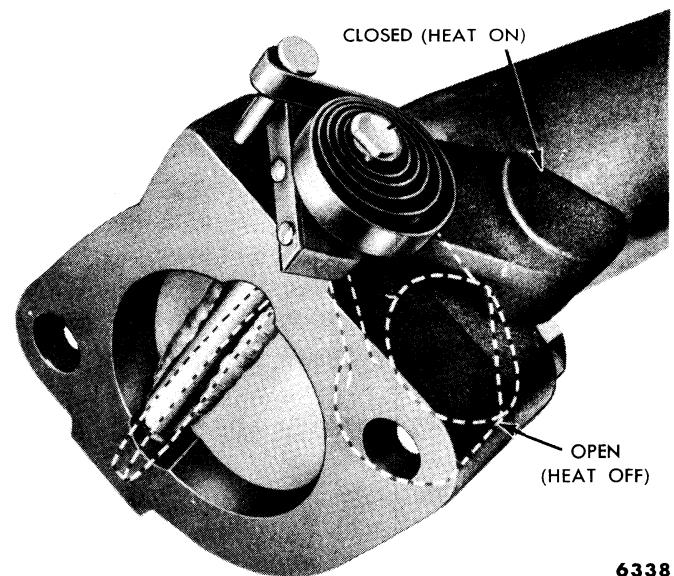

6338

Fig. 7—Exhaust Control Valve—Dual Exhaust System

ever, a properly operating valve will open when very light finger pressure is applied to the counterweight. Rapidly accelerate the engine to make sure the valve momentarily opens. The valve is designed to open when the engine is at normal operating temperature and is operated at high r.p.m. Free stuck valves with a penetrating oil or kerosene and graphite mixture.

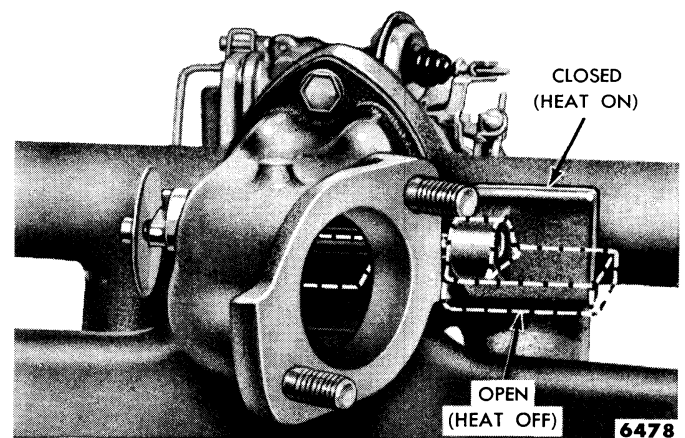

6478

Fig. 8—Exhaust Control Valve—6-Cylinder Engine

5. ROCKER MECHANISM, CYLINDER HEAD, VALVES, VALVE LASH ADJUSTMENT, AND VALVE TIMING

This section covers the inspection and repair procedures applicable to the rocker mechanism, cylinder head, and valves. In addition, the methods used to adjust the valve lash and to check valve timing are given.

a. Rocker Mechanism.

The rocker mechanism parts are individually replaceable.

(1) **CLEANING AND INSPECTION.** Check the I. D. of the rocker arm bore and the O. D. of the rocker arm shaft at the location of the rocker arms. Inspect the rocker arms for grooved pads. Check the rocker adjust-

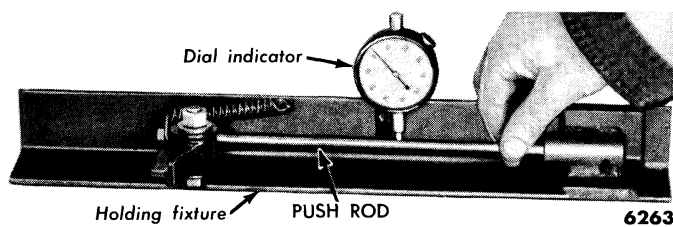

Fig. 9—Push Rod Runout Check

ing screws and lock nuts for stripped or broken threads, and the ball end of the screw for nicks and scratches or excessive wear.

Inspect the locating springs for cracks or other signs of failure.

Inspect the oil drain tube for cracks or sharp bends. Check the ball end and socket end of the push rods for nicks, grooves, roughness, or excessive wear.

A suitable check for bent push rods can be made while they are installed in the engine by rotating them (valve closed) or they can be checked between ball and cup centers with a dial indicator (fig. 9).

If the total runout of a push rod exceeds 0.020 inch, at any point, discard the rod. Do not attempt to straighten it.

(2) **REPAIRS.** If the clearance between the shaft and rocker arms is excessive, replace the shaft and/or the rocker arms. Replace all rocker arms that have severely scored or scuffed bores and/or grooved pads. Replace all scored or scuffed rocker shafts. Dress up minor nicks or scratches. Replace all damaged adjusting screws, lock nuts, and springs.

Replace the oil drain tube if it is cracked or has a sharp bend.

b. Cylinder Heads.

To protect the machined surfaces of the cylinder heads, do not remove the holding fixtures while the heads are off the engine.

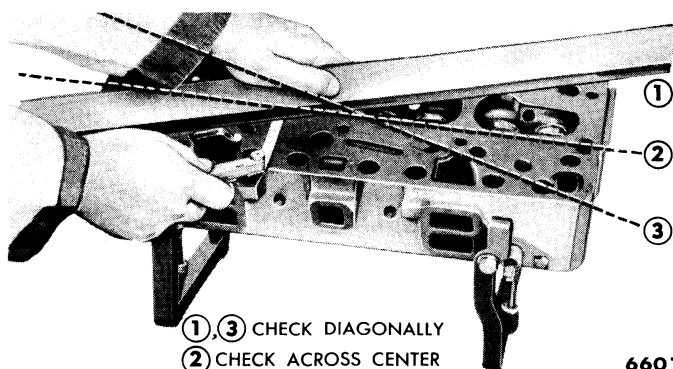

Fig. 10—Checking Flatness of the Cylinder Head Gasket Surface—Typical

(1) **CLEANING AND INSPECTION.** With the valves installed to protect the valve seats, remove carbon deposits from the combustion chamber and valve heads with a scraper and a wire brush. Be careful not to scratch the gasket surface. Clean the heads with solvent to remove old gasket sealer, dirt, and grease.

Check the head for cracks. Check the gasket surface for burrs, nicks, and for flatness (fig. 10). Service specifications for flatness are 0.006 inch maximum over all, or 0.003 in any six inches. Make sure all water passages are open. Check the cylinder head core plug for evidence of leakage.

(2) **REPAIRS.** Replace the head if it cracked, or if it is damaged beyond repair.

NOTE: Do not plane or grind excessive material from the cylinder head gasket surface as the compression ratio is altered when this operation is performed.

Remove all burrs or scratches with an oil stone.

Replace any core plugs that show signs of leakage.

(3) **SPARK PLUG HOLE ADAPTERS.** If it is desired to use standard 14 millimeter spark plugs, an adapter is available which reduces the 18 millimeter hole to 14 millimeters. The adapter installation procedure is as follows:

Position a spark plug gasket on a standard 14 millimeter plug and install the plug in an adapter. Insert the spark plug and adapter assembly into the 18 millimeter hole and tighten the plug to 25-30 foot-pounds torque. This torque is sufficient to seal the adapter in place and it will not back out when the spark plug is removed. Once the adapters are installed, standard 14 millimeter spark plug gap and torque specifications apply.

c. Valve Mechanism.

Valve guides are made integral with the cylinder heads. Valves with oversized stems are available as replacements if it becomes necessary to ream the valve guides.

(1) **CLEANING AND INSPECTION.** Discard umbrella-type valve stem seals, and replace with new seals. Scrape and/or wire brush carbon from the head and stem of the valves and from the inside of the guides. Remove varnish from the valve stems. Carefully clean all carbon from the valve seat with a fine wire brush.

Check the valve for evidence of imperfect seating, heavy discoloration, burning or erosion, or warpage. Check the valve face runout (fig. 11), and also check the face for pits and grooves. Inspect the ends of the valve stem for grooves or scores.

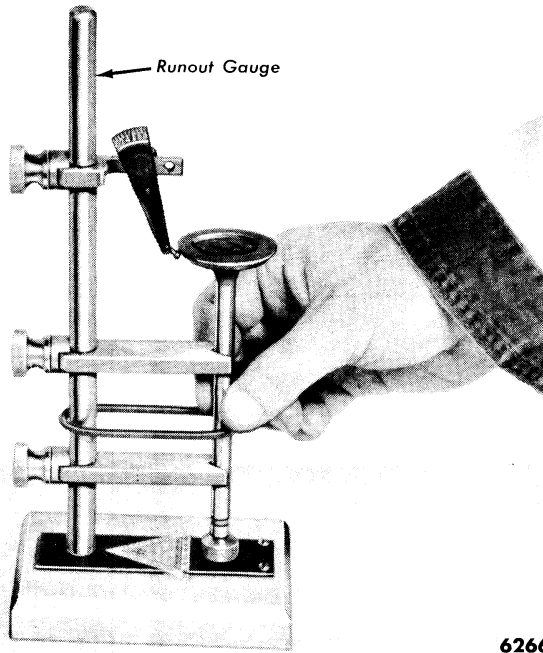

Fig. 11—Valve Face Runout Check

Inspect the valve springs for signs of failure. Check the valve spring for proper pressure (fig. 12) and squareness (fig. 13).

Check the valve spring retainers, locks, and sleeves for wear or signs of failure.

Check the valve stem clearance of each valve in its respective valve guide as shown in fig. 14. Install the tool on the valve stem until fully seated and tighten the set screw, then permit the valve to drop away from its seat until the tool contacts the upper surface of the

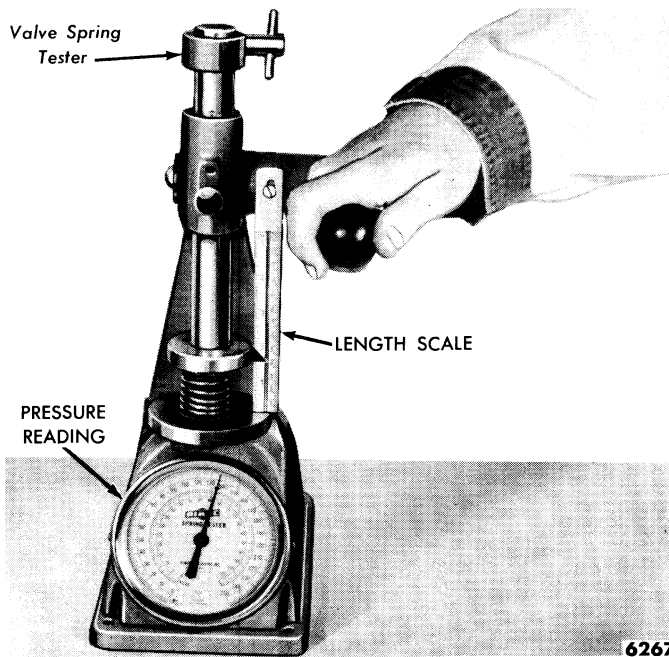

Fig. 12—Valve Spring Pressure Check

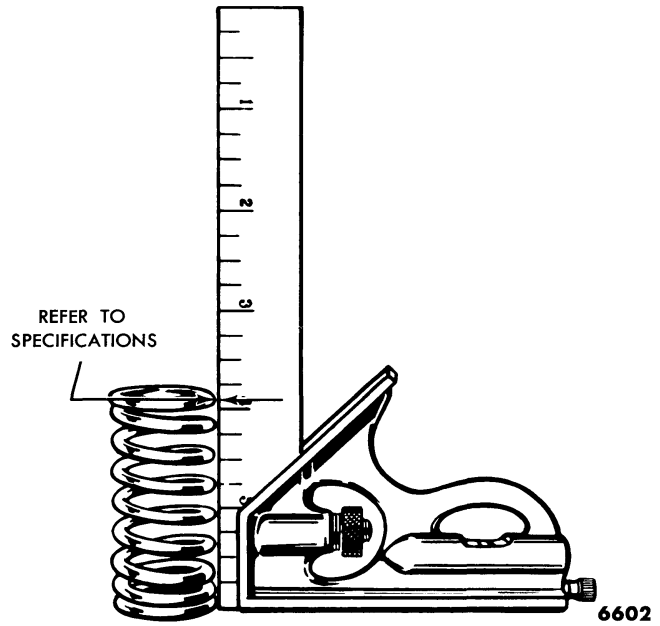

Fig. 13—Valve Spring Squareness Check

valve guide. Position a dial indicator with a flat tip against the center portion of the spherical section of the tool at approximately 90° to the valve stem. Move the tool back and forth on a plane that parallels normal rocker action and take the indicator reading without lifting the tool from the valve guide upper surface. Divide the indicator reading by 2 (division factor of the tool) to obtain the actual stem clearance.

Check the valve seat runout and the valve seat width as shown in figs. 15 and 16.

(2) **REPAIRS.** Discard any defective valves, springs, locks, retainers, or sleeves.

(a) **REFACING VALVES.** If the valve face runout is excessive, grind the valve face at a 45° angle on a

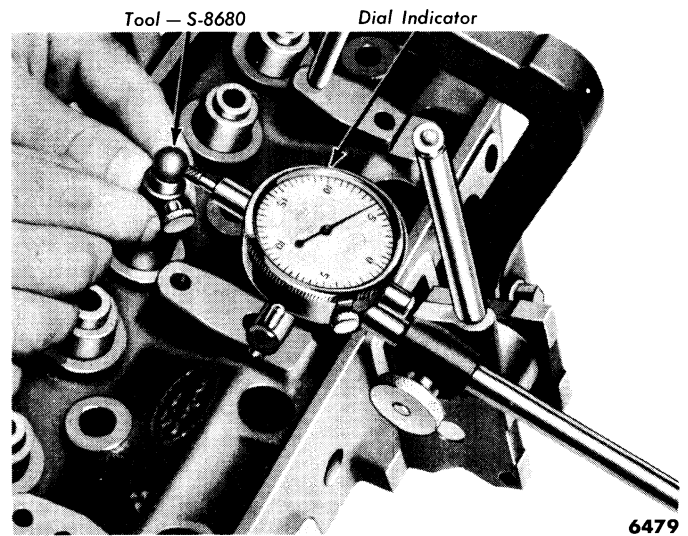

Fig. 14—Valve Stem Clearance Check—Typical

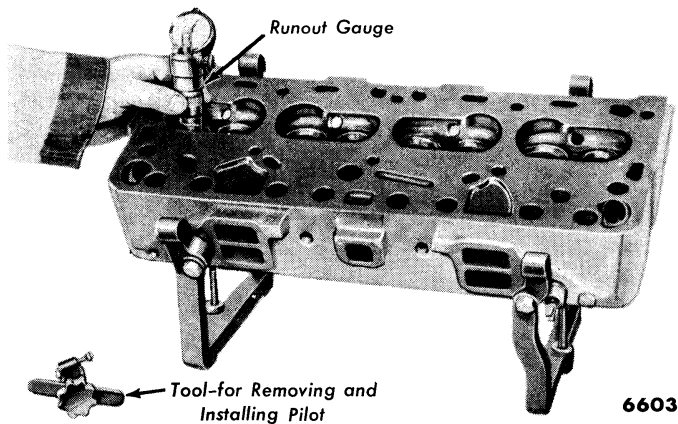

Fig. 15—Valve Seat Runout Check—Typical

precision valve grinder. Follow the instructions of the equipment manufacturer. Grind off only enough stock to remove pits and grooves. If the edge of the valve head is less than $\frac{1}{32}$ inch thick after grinding, replace the valve. If the runout still exceeds specifications after grinding, check the equipment used in the grinding operation.

Grind all grooves or score marks from the end of the valve stem. Do not remove more than 0.010 inch from the stem.

The critical tolerances of the valve are illustrated in fig. 17.

(b) **REFACING VALVE SEATS.** Grind the valve seat (fig. 18) to a true 45° angle. Remove only enough stock to clean up pits or grooves. If the valve seat width exceeds specifications, remove just enough stock from the top and/or bottom edge of the seat to reduce the width to specifications. Use a 30° angle wheel to remove stock from the bottom of the seat and a 60° angle wheel to remove stock from the top (fig. 19). Keep the seat as near to the center of the valve face as possible. Place Prussian Blue on the valve seat and install the valve to check the point of contact.

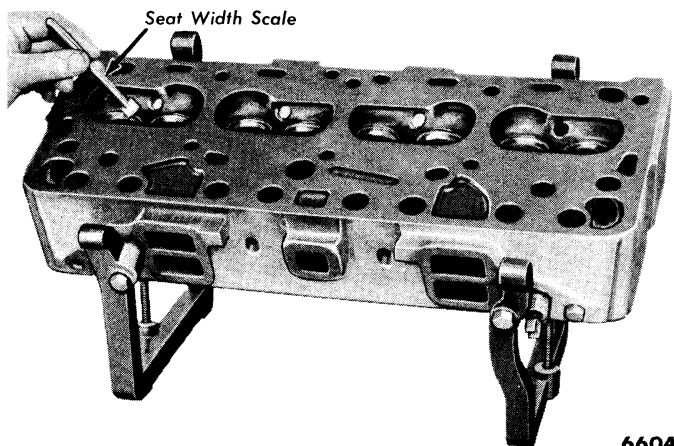

Fig. 16—Measuring Valve Seat Width—Typical

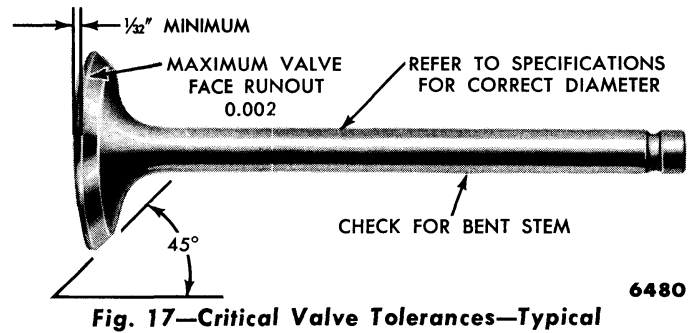

Fig. 17—Critical Valve Tolerances—Typical

After refacing valves and seats, it is good practice to lightly lap in the valves with a medium grade lapping compound to match the seats.

(c) **SELECT FITTING VALVES.** Oversize valves with a stem diameter of 0.003, 0.015, and 0.030 inch are available. Occasionally the 0.003 inch oversize valve is used in production in one or more positions.

If the valve to guide stem clearance is excessive and the diameter of the valve stem is on the lower limit (as determined by measuring the valve stem with a micrometer), select a new valve with a stem diameter on the upper limit. If in the use of standard valves the clearance cannot be reduced to a satisfactory limit, ream the valve guide (fig. 20) for the next oversize valve stem.

d. Valve Lash Adjustment.

Reference is made in the procedures for a preliminary (cold) valve lash adjustment to placing number 1 piston on top dead center (T.D.C.) at the end of the compression stroke. Number 1 piston is on T.D.C. at

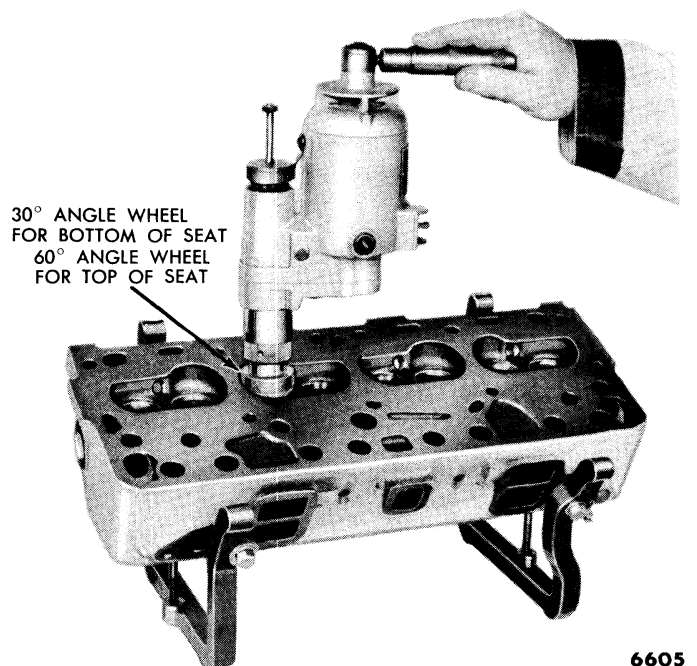

Fig. 18—Refacing Valve Seat—Typical

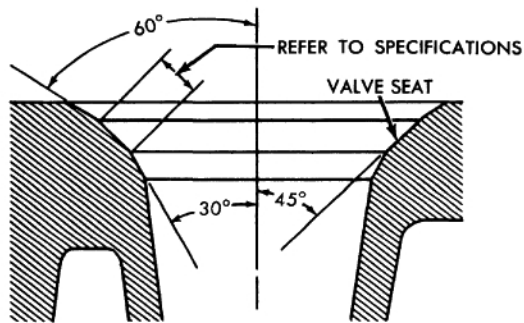

Fig. 19—Valve Seat Width

6292

the end of the compression stroke when both valves are closed and the timing mark on the crankshaft damper is in line with the timing pointer.

Step-type feeler gauges ("go" and "no go") can be used to obtain the proper clearance (fig. 21).

Valve lash is adjusted by means of the set screw and lock nut located on the push rod end of the rocker arm.

It is very important that the lash of all valves be held as close as possible to the correct specifications. If the lash is set too close, rough engine idle and poor engine performance can result. If the valve lash is excessive, valve action noise will result, and engine performance will be affected.

NOTE: *The preliminary and final valve lash adjustment specification (intake and exhaust) for all engines is 0.019 (See page 367 for "Practical Method")*

If the cylinder head or the rocker mechanism has been removed and installed, it will be necessary to make a preliminary (cold) valve lash adjustment before starting the engine. If the adjustment is made for the purpose of engine tune-up, omit step (a) and proceed with step (b) under the procedure for the applicable engine.

(1) **6-CYLINDER ENGINE.** Remove the rocker arm cover.

(a) **PRELIMINARY ADJUSTMENT.** Make two chalk marks on the crankshaft damper. Space the marks approximately 120° apart so that with the timing mark, the damper is divided into three equal parts (120° represents $\frac{1}{3}$ of the distance around the damper circumference).

Rotate the crankshaft until number 1 piston is near T.D.C. at the end of the compression stroke. Adjust the intake and exhaust valve lash for number 1 cylinder.

Repeat this procedure for the remaining set of valves, turning the crankshaft $\frac{1}{3}$ turn at a time, in the direction of rotation, while adjusting the valves in the firing order sequence (1-5-3-6-2-4).

(b) **FINAL ADJUSTMENT.** Run the engine for a minimum of 30 minutes at approximately 1200 r.p.m. in order to stabilize engine temperatures. With the engine idling, check the valve lash. Adjust the lash, if necessary (fig. 21). Install the rocker arm cover.

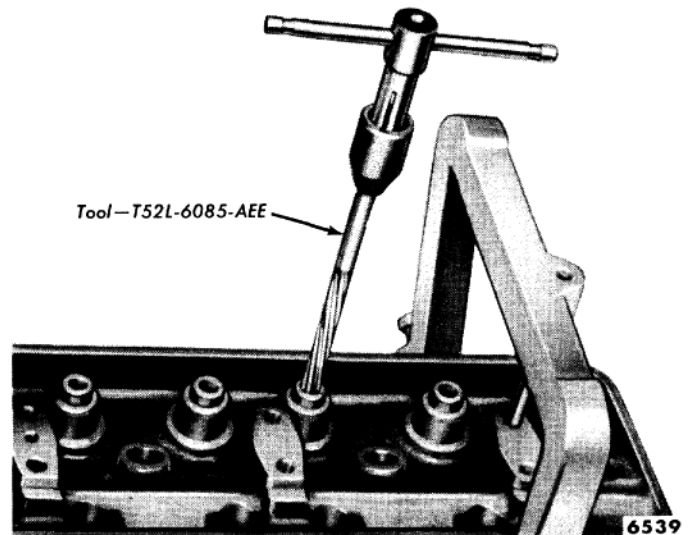

Fig. 20—Reaming Valve Guides—Typical

(2) **8-CYLINDER ENGINES.** Remove the rocker arm covers.

(a) **PRELIMINARY ADJUSTMENT.** Make three chalk marks on the crankshaft damper. Space the marks approximately 90° apart so that with the timing mark, the damper is divided into four equal parts (90° represents $\frac{1}{4}$ turn of the crankshaft or $\frac{1}{4}$ of the distance around the damper circumference).

Rotate the crankshaft until number 1 piston is near T.D.C. at the end of the compression stroke and the timing mark on the damper is aligned with the timing pointer.

Combination Adjusting Tool

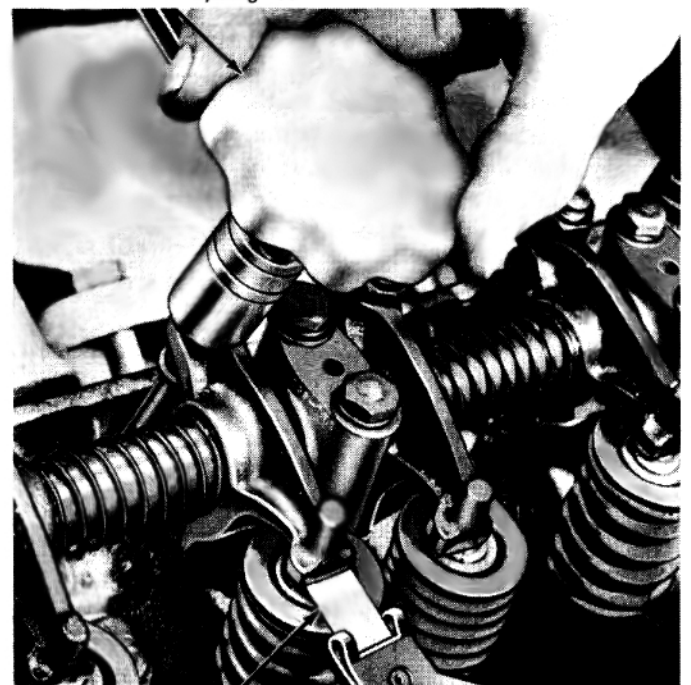

Fig. 21—Valve Lash Adjustment—Typical

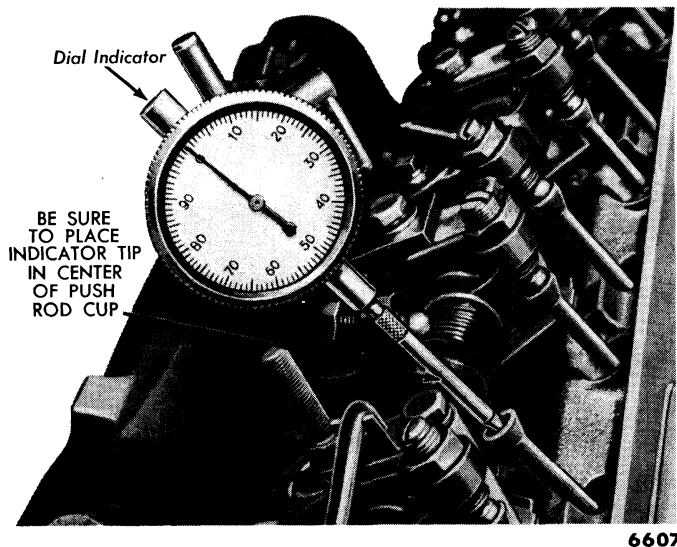

Fig. 22—Camshaft Lobe Lift Check—Typical

Adjust the lash on the following valves:

No. 1—Exhaust	No. 1—Intake
No. 4—Exhaust	No. 2—Intake
No. 5—Exhaust	No. 7—Intake

Rotate the engine 180° or ½ turn (this puts number 4 piston on T.D.C.) and adjust the following valves:

No. 6—Exhaust	No. 4—Intake
No. 8—Exhaust	No. 5—Intake

Rotate the engine 270°, or ¾ turn from 180° (this puts number 3 piston on T.D.C.) and adjust the following valves:

No. 2—Exhaust	No. 3—Intake
No. 3—Exhaust	No. 6—Intake
No. 7—Exhaust	No. 8—Intake

(b) **FINAL ADJUSTMENT.** Run the engine for a minimum of 30 minutes at approximately 1200 r.p.m. in order to stabilize engine temperatures. With the engine idling, check the valve lash. Adjust the lash, if necessary (fig. 21). Install the rocker arm covers.

e. Valve Timing.

Valve timing checks should be made when poor

engine performance is noted and all other checks, such as carburetion, ignition timing, etc., fail to correct the trouble. The following procedure can be used to determine if the valve timing is correct with the engine installed in the car.

The procedure checks the cam timing by using the opening side of number 1 intake cam lobe. At this point 1° of crankshaft rotation is equal to approximately 0.0004 inch change in cam lift.

Remove the rocker arm cover on the 6-cylinder engine. On 8-cylinder engines, remove the right rocker arm cover.

Back off the number 1 intake valve adjusting screw, then slide the rocker arm assembly to one side and secure it in this position. Make sure the push rod is in the tappet socket, then install a dial indicator in such a manner as to have the actuating point of the indicator in the push rod socket and in the same plane as the push rod movement (fig. 22). Turn the engine slowly (at either the crankshaft damper bolt or flywheel) until the tappet is on the heel of the cam lobe. Zero the dial indicator and continue turning the engine slowly until the desired lift is obtained (Table 1). Compare the degrees on the pulley with specifications.

Table 1—Valve Timing Specifications

Engine (Cubic Inch Displacement)	Intake Valve Opens—Crankshaft Degrees at Cam Lift
223	24° BTDC@ .016 Cam Lift
272, 292 and 312	12° BTDC@ .016 Cam Lift

If the valve timing is not within specifications, check for a bent timing pointer. Bring the number 1 piston to T.D.C. and see if the timing pointer is aligned with the T.D.C. mark on the crankshaft pulley or damper. If the pointer is not at fault, check the timing chain, camshaft sprocket, crankshaft sprocket, camshaft, and crankshaft pulley, in the order of accessibility.

6. TIMING CHAIN, SPROCKETS, AND CAMSHAFT

a. Timing Chain and Sprockets.

To measure timing chain deflection (fig. 23), take up the slack on the left side (as viewed from the front) of the chain by rotating the crankshaft in a clockwise direction. Establish a reference point on the block and measure from this point to the chain. Rotate the crankshaft to move all the slack to the left side. With the

fingers, move the chain toward the original reference point and measure the distance between the reference point and the chain. If the difference between the two measurements (which is the slack) exceeds ½ inch, replace the timing chain and/or sprockets.

(1) **INSPECTION.** Inspect the sprockets for worn or damaged teeth. Inspect the chain for broken links.

(2) **REPAIRS.** Replace the sprockets or the timing chain as deemed necessary by inspection. However, it is recommended that all the components be replaced if any one item needs replacement.

b. Camshaft.

The camshaft should be replaced when any lobe (intake or exhaust) is worn to such an extent that the lift loss exceeds 0.005 inch. The tappet which mates with the worn lobe must also be replaced.

(1) **CAM LOBE LIFT CHECK.** This procedure is similar to the procedure for checking valve timing. Loosen the valve rocker arm adjusting screw, then slide the rocker arm assembly to one side and secure it in this position. Make sure the push rod is in the tappet socket, then install a dial indicator in such a manner as to have the actuating point of the indicator in the push rod socket and in the same plane as the push rod movement (fig. 22). Rotate the engine slowly until the tappet is on the heel of the cam lobe. Zero the dial indicator, then continue to rotate the engine slowly until the push rod is in the fully raised position. Compare the total lift recorded on the indicator with specifications. Continue to rotate the engine until the indicator reads zero. This later step is a check on the accuracy of the original indicator reading.

(2) **INSPECTION.** Thoroughly check the camshaft for damage. Examine the lobes for pitting, scoring, and signs of abnormal wear. Check the lobes with a micrometer. Suspected worn lobes should be compared with a good lobe to be sure diagnosis is correct. Measure the journal diameter for wear and out-of-roundness. Measure the I. D. of the camshaft bearings. If the clearances are excessive the cam and/or cam bearings should be replaced. Check the fuel pump eccentric for wear.

(3) **REPAIRS.** Replace all camshafts that are damaged beyond repair. Remove light scuffs, scores, or nicks with a hard Arkansas stone, then polish with crocus cloth.

The lobe wear characteristics may result in pitting in the general area of the nose portion of the lobe. This pitting is not detrimental to the operation of the cam if the initial cam lobe lift loss has not exceeded 0.005 inch. The camshaft will continue to operate satisfactorily for the normal life expectancy of the engine without noticeably affecting engine performance. Therefore, camshafts should not be replaced unless the lobe lift loss exceeds the above specification or the tappet contact face shows evidence of failure.

Normally if the front journal to bearing clearance is excessive, it can be assumed that all bearings are worn and need replacement.

If any of the teeth on the distributor drive gear are

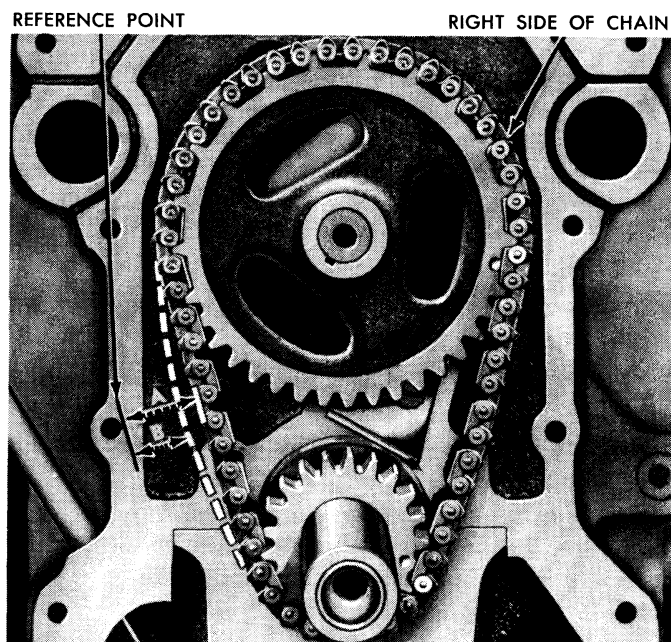

TAKE UP SLACK ON LEFT SIDE OF CHAIN. ESTABLISH A REFERENCE POINT AND MEASURE DISTANCE A. THEN, TAKE UP SLACK ON RIGHT SIDE OF CHAIN AND FORCE LEFT SIDE OF CHAIN OUT WITH THE FINGERS AND MEASURE DISTANCE B. DEFLECTION IS A. MINUS B. 6608

Fig. 23—Timing Chain Deflection—Typical

broken, worn, or scored it will be necessary to replace the camshaft.

(4) **CAMSHAFT END PLAY CHECK.** Push the camshaft toward the rear of the engine. Place a dial indicator point against a suitable surface on the front end of the camshaft assembly (fig. 24). Set the dial to zero, then pull the camshaft forward and release it. Compare the dial reading with specifications.

If the end play is excessive, check the spacer for correct installation. Replace the thrust plate and/or spacer if necessary.

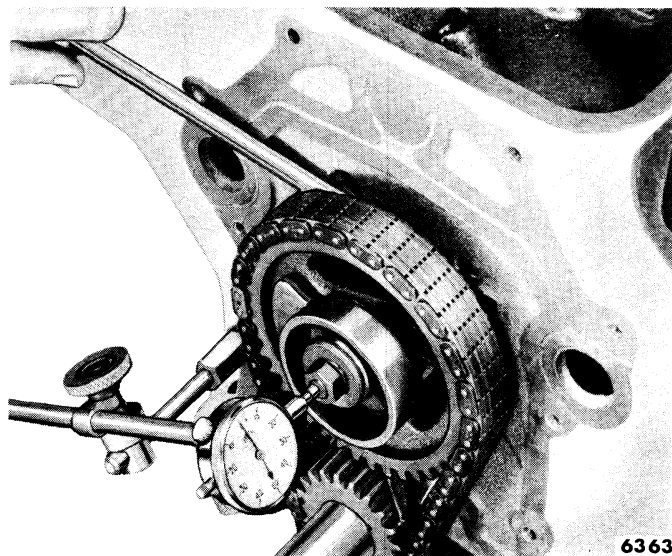

Fig. 24—Camshaft End Play Check—Typical

7. FLYWHEEL, CRANKSHAFT, AND MAIN BEARINGS

Procedures for the inspection and repair of these components are given here. In addition, procedures for fitting main bearings, aligning the thrust bearing, and replacing the rear main bearing crankshaft oil seal are given.

a. Flywheel.

The flywheel and ring gear are a shrink fit and are replaceable as separate parts.

(1) **INSPECTION.** Check the flywheel face runout with a dial indicator (fig. 25). Be sure to hold the flywheel full forward or rearward so that crankshaft end play will not be indicated as flywheel runout. If the runout is excessive, remove the flywheel, and check the runout of the crankshaft mounting flange. It will be necessary to remove the crankshaft if the flange requires machining.

Inspect the ring gear for worn, chipped, or cracked teeth. Check the ring gear runout as indicated in fig. 26.

(2) **REPAIRS.** If the flywheel runout is excessive and the flange is not at fault, replace or machine the flywheel. Machine the friction surface of the flywheel if it is scored or worn. If it is necessary to remove more than 0.045 inch of stock from the original thickness, replace the flywheel.

If the ring gear teeth are damaged and unfit for further use, or if the runout is excessive, replace the ring gear as follows:

Heat the defective ring gear with a blow torch on the engine side of the gear, then knock it off the flywheel.

CAUTION: *Do not hit the flywheel when removing the ring gear.*

Heat the new ring gear evenly until the gear expands enough to slip onto the flywheel. Make sure the gear is seated properly against the shoulder.

CAUTION: *Do not heat any portion of the gear to a temperature higher than 500°F. If this limit is exceeded, the temper will be removed from the ring gear teeth. When the new ring gear is installed, perform a runout check on the ring gear and flywheel.*

b. Crankshaft.

Check the end play in the following manner:

Push the crankshaft toward the rear of the engine. Place a dial indicator point against the rear or front end of the crankshaft. Set the dial on zero, then push the crankshaft forward. Compare the reading on the dial indicator with specifications.

(1) **CLEANING AND INSPECTION.** Remove the crankshaft, wash it in a solvent, and blow out the oil passages with compressed air. Examine the shaft for damage.

Measure the diameter of each journal in at least four places to determine out-of-round, taper, or undersize condition (fig. 27).

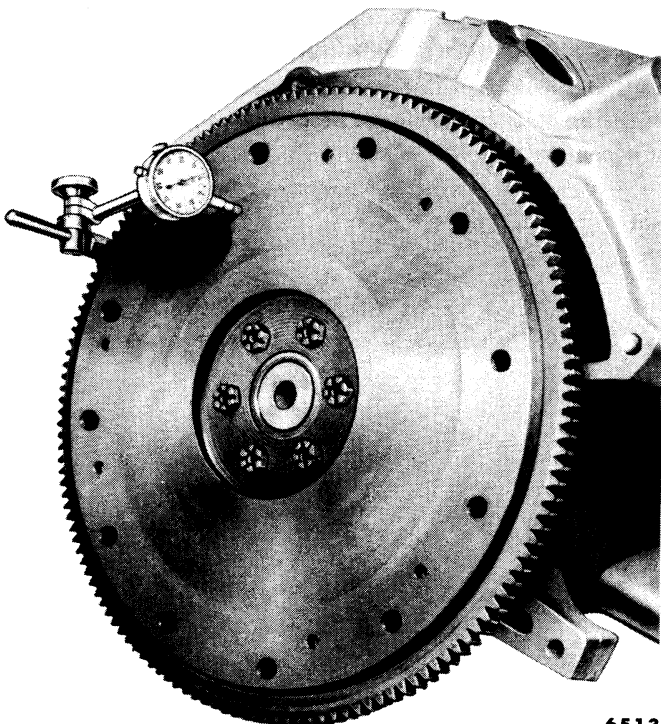

6513

Fig. 25—Flywheel Runout Check—Typical

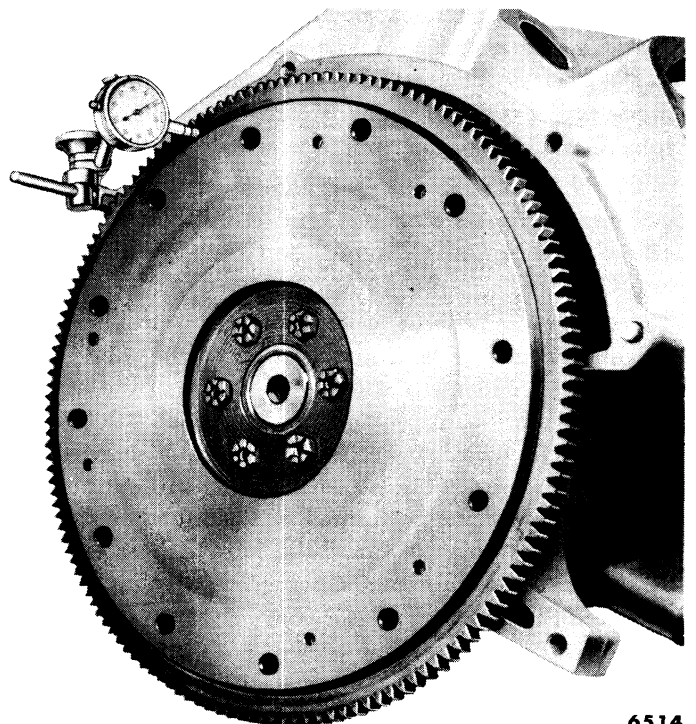

6514

Fig. 26—Ring Gear Runout Check—Typical

(2) **REPAIRS.** If the end play is excessive, replace the thrust bearing.

Replace the crankshaft if it shows signs of failure. Dress minor nicks or scratches.

If the pins or journals are out-of-round beyond further use, the shaft should be ground for the next undersize bearing. Calculate the correct undersize bearing to be used as follows:

EXAMPLE: *If the main bearing journal will “clean-up” before it is ground to $2.499 - 0.010 = 2.489$ inches diameter, finish it to that diameter, and install 0.010 inch undersize bearings.*

Always reproduce the same radii in the corners of the journals that existed originally. Too small a radius will result in bearing failure.

CAUTION: *Never grind journals or crankpins in excess of 0.030 inch undersize.*

After grinding, chamfer the oil holes, then polish the pin or journal with number 320 grit polishing cloth and engine oil. Crocus cloth may also be used as a polishing agent.

c. Main Bearings.

The insert-type main bearings are select fit. They are available for service in standard and undersizes for use on journals that have been reground. The installation of new bearings must be closely checked to maintain the proper clearance between the journals and bearing surfaces.

(1) **INSPECTION.** Check the bearings for any damage or excessive clearance. Examples of bearing failures and their causes are illustrated in fig. 28.

(2) **FITTING MAIN BEARINGS — PLASTIGAGE METHOD.** The following procedure applies to fitting main bearings with the engine either installed on a

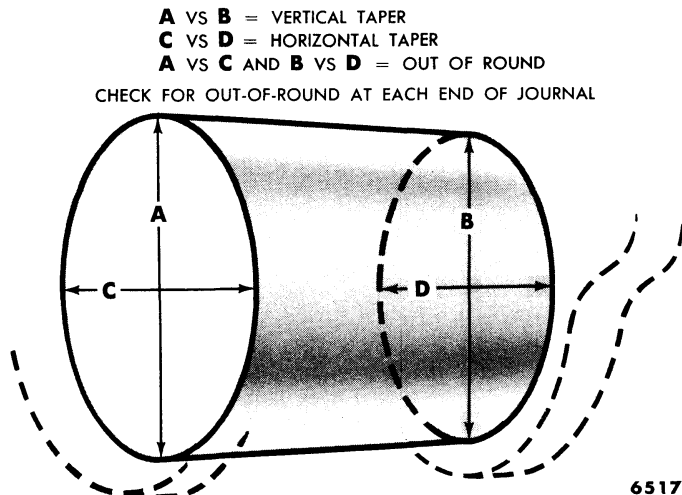

Fig. 27—Checking Crankshaft Journal

workstand or in the car.

If the bearing fits are to be checked with the engine in the car, support the weight of the crankshaft with a small jack positioned to hold the crankshaft upward against the block half of the main bearings. Place the jack to bear against the crankshaft counterweight adjoining the bearing which is being checked for clearance. The shaft can also be supported by a thin rubber pad between the cap insert and the journal of two bearings that are not being checked. Tighten the bearing cap bolts just enough to hold the crankshaft up against the upper bearings.

NOTE: *It is necessary to support the weight of the crankshaft when checking main bearing clearances to prevent the weight of the crankshaft from compressing the Plastigage, thereby providing an erroneous reading.*

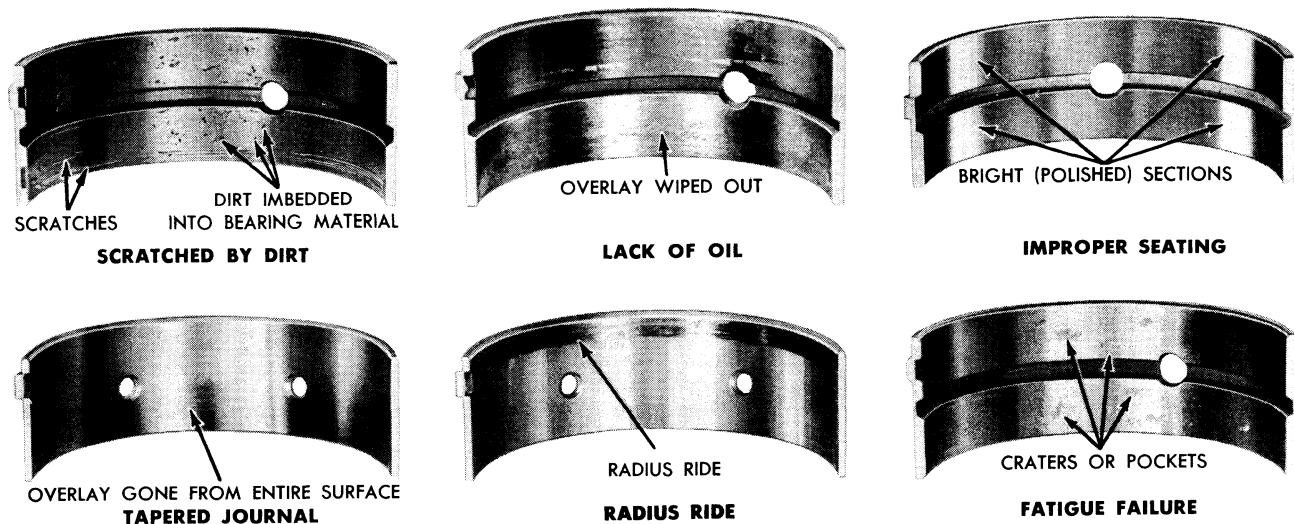

Fig. 28—Bearing Failures—Typical

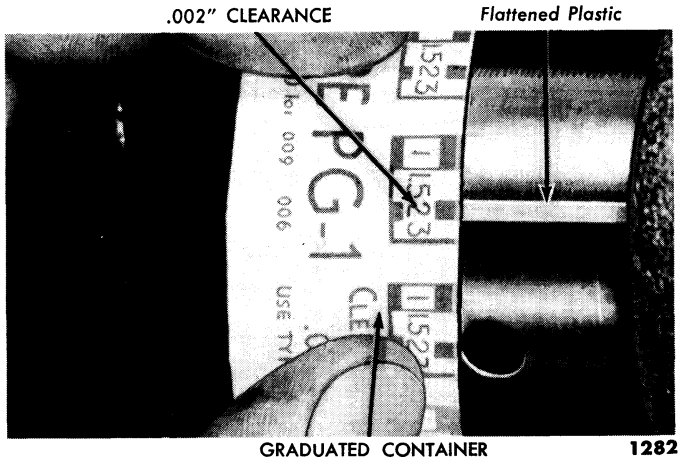

Fig. 29—Measuring Plastigage—Typical

Place a piece of Plastigage, the full width of the bearing cap, on the bearing surface (or on the crankshaft journal if the engine is inverted) about $\frac{1}{4}$ inch off center. Install the cap and tighten the bolts to specifications.

CAUTION: Do not turn the crankshaft while the Plastigage is in place.

Remove the cap, then check the width of the Plastigage at the widest point with the Plastigage scale (fig. 29).

If the clearance is excessive, try another selective fit bearing to bring the clearance within the desired limit.

NOTE: Red marked bearings increase clearance; blue marked bearings decrease clearance.

If the various selective fit bearings do not bring the clearance within the desired limits, grind the crankshaft journal and/or journals and install undersize bearings.

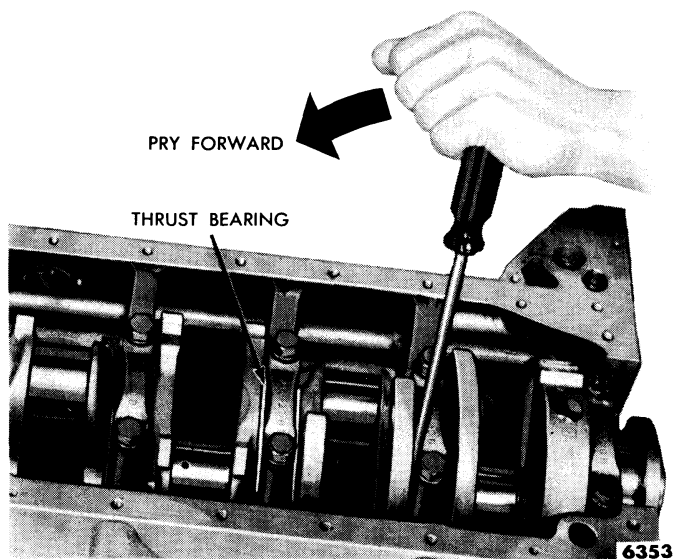

Fig. 30—Pry Crankshaft Forward—Typical

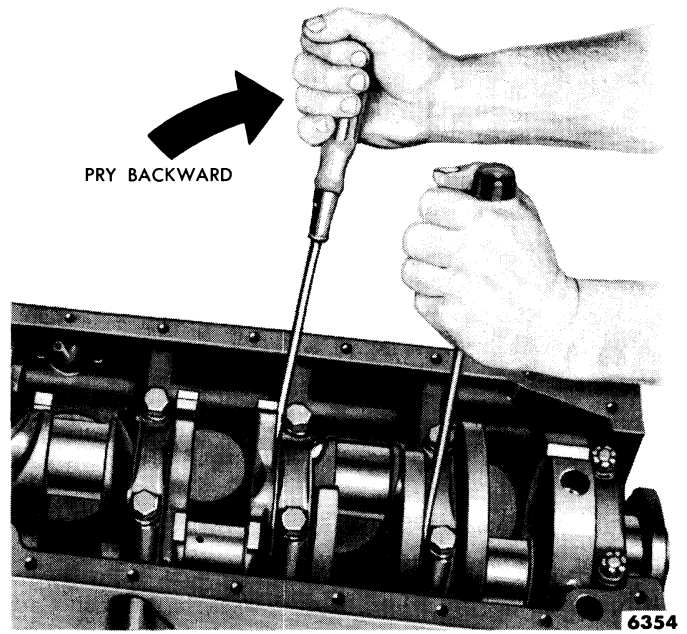

Fig. 31—Pry Cap Backward—Typical

NOTE: Normally, main bearing journals wear evenly and are not out-of-round. However, if a bearing is being fitted to an out-of-round journal, be sure to fit the bearing to the maximum diameter of the journal. If the bearing is fitted to the minimum diameter with minimum clearance, interference may result, causing an early failure. It is not recommended that bearings be fitted to a crankshaft journal which is more than 0.001 inch out-of-round.

(3) **THRUST BEARING ALIGNMENT.** Install the main bearing caps, except the thrust bearing cap, and tighten the bolts to specifications. Install the thrust

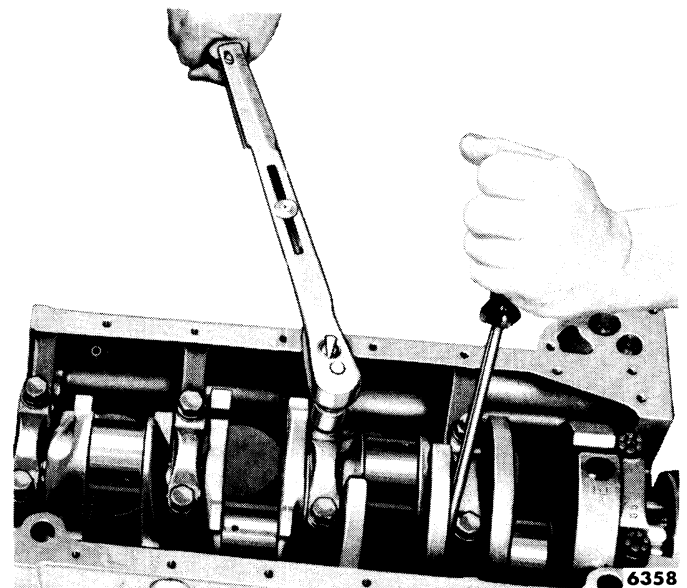

Fig. 32—Tighten Cap—Typical

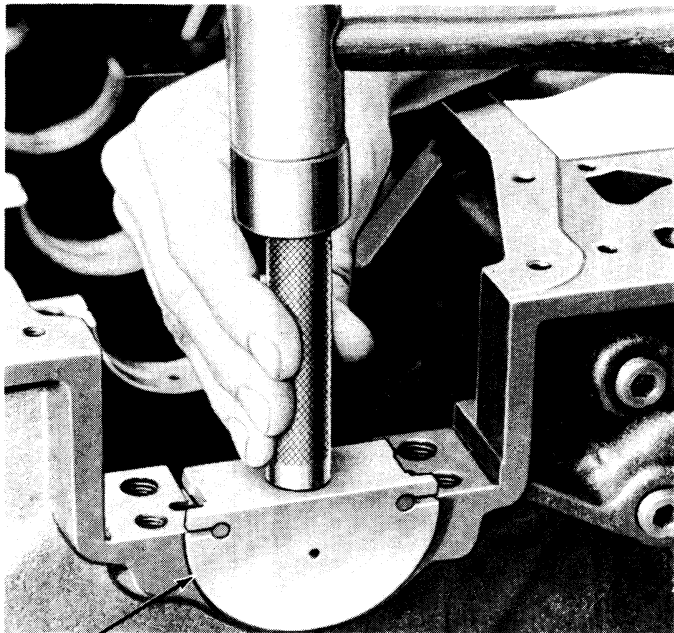

Fig. 33—Oil Seal to Block Installation—Typical

bearing cap with the bolts finger-tight, then pry the crankshaft forward against the thrust surface of the upper half of the bearing (fig. 30). While holding the crankshaft forward, pry the thrust bearing cap to the rear (fig. 31). This will align the thrust surfaces of both halves of the bearing. Retain the forward pressure on the crankshaft, and tighten the cap bolts to specifications (fig. 32). Check the crankshaft end play.

(4) **REPLACING REAR MAIN BEARING CRANKSHAFT OIL SEALS.** Remove the crankshaft journal oil seals from the cylinder block and seal retainer or bearing cap. Clean the seal grooves.

Install the new seal in the cylinder block as shown in fig. 33. After installation, cut the seals flush without any frayed edges overlapping. Install the new journal seal in the retainer or bearing cap as shown in fig. 34. After installation cut the seals flush.

Coat the rear oil seal retainer to block mating face with sealer, install the retainer and tighten the bolts to

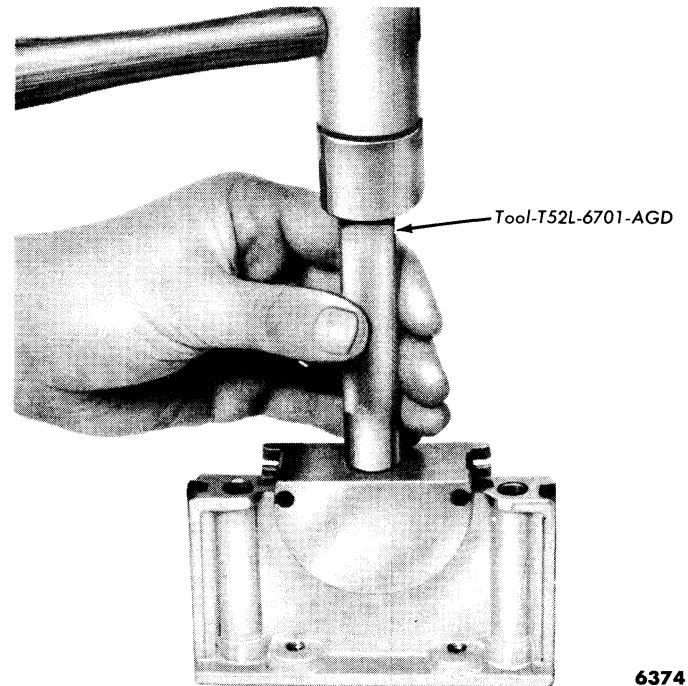

Fig. 34—Oil Seal to Retainer Installation—Typical

23-28 foot-pounds torque. Dip the retainer side seals in light engine oil, then immediately install them in the grooves. It may be necessary to tap the seals into place for the last $\frac{1}{2}$ inch of travel. Do not cut the seal projecting ends.

CAUTION: *Do not use sealer on the side seals. The seals are designed to expand when dipped in oil. Using sealer may retard this expansion.*

To check retainer or bearing cap side seals for leaks, squirt a few drops of oil into the parting lines between the cap or retainer and the cylinder block from the outside. Blow compressed air against the seals from the inside of the block. If air bubbles appear in the oil, it indicates possible oil leakage.

NOTE: *The above test should not be performed on newly installed seals until sufficient time has been allowed for the seals to expand into the seal grooves.*

8. CYLINDER BLOCK, PISTONS, PISTON RINGS, AND CONNECTING RODS AND BEARINGS

During the disassembly of the cylinder block for engine overhaul, closely inspect the wear pattern on all parts to help diagnose the cause of wear.

a. Cylinder Block.

Clean old gasket material from all machined surfaces. Remove the pipe plugs which seal oil passages and clean all passages thoroughly.

(1) **INSPECTION.** Make a thorough check for cracks. Minute cracks not visible to the naked eye may be detected by coating the suspected area with a mixture of 25% kerosene and 75% light motor oil. Wipe the part dry and immediately apply a coating of zinc oxide dissolved in wood alcohol. If cracks are present, the coating will become discolored at the defective area.

Make sure the threads in the head bolt holes are

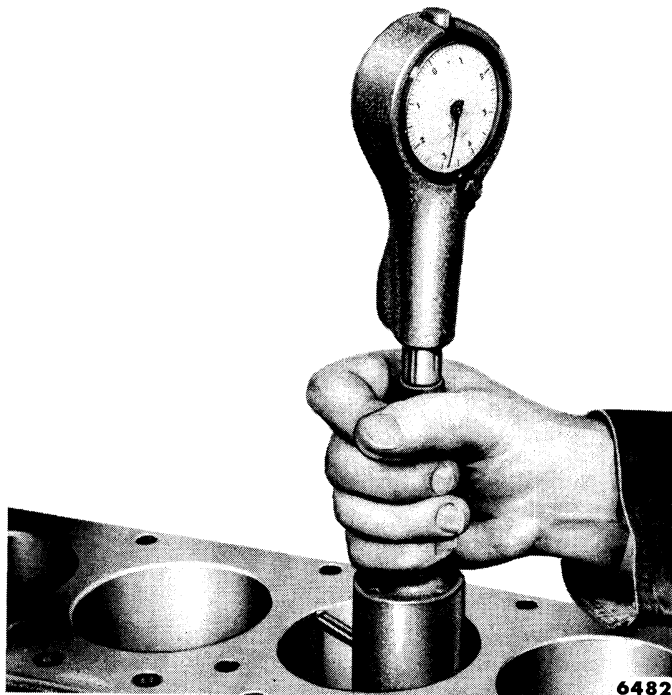

Fig. 35—Cylinder Bore Measurement—Typical

clean. Dirt in the threads can cause binding and result in a false torque reading. Use a tap to true up threads and to remove deposits if necessary.

Inspect the cylinder bores for scoring, taper, out of roundness, and wear. Use a cylinder bore gauge to make the measurements (fig. 35). Follow the instructions of the tool manufacturer. Only experienced personnel should be permitted to take these measurements.

Inspect all expansion-type plugs for evidence of leakage.

(2) **REPAIRS.** To remove an expansion-type plug, drill a $\frac{1}{2}$ inch hole in the center of the plug and remove the plug as shown in fig. 36. Clean the plug recess thoroughly. Coat the flange of the new plug with sealer and install it with the flange facing out. Drive the plug in until the flange is flush or slightly below the casting surface (fig. 37).

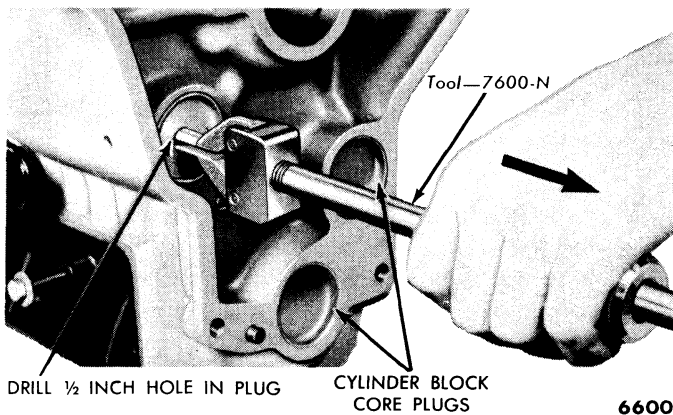

Fig. 36—Expansion-Type Plug Removal—Typical

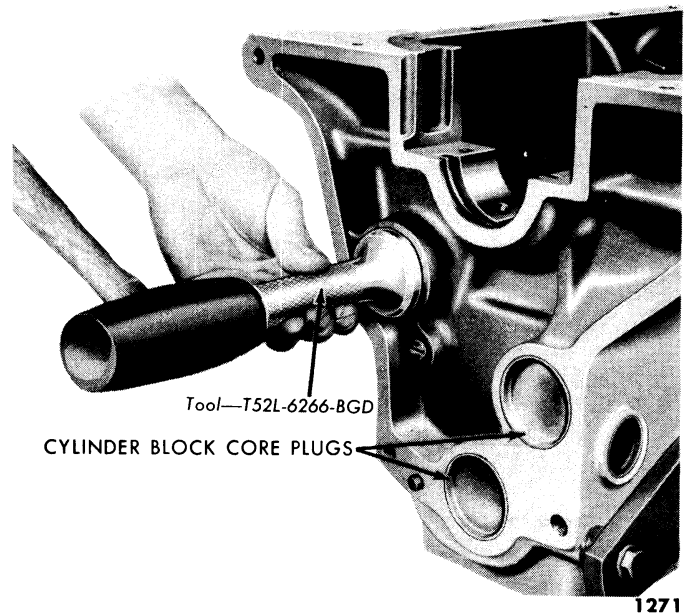

Fig. 37—Expansion-Type Plug Installation—Typical

NOTE: A 0.030 inch oversize plug is available.

Rebore cylinders that are deeply scored and when taper and/or out-of-roundness are excessive. If the cylinder bore and piston wear are not excessive, new service piston rings will give satisfactory performance.

(3) **BORING CYLINDER BLOCK.** Follow the boring equipment manufacturer's instructions. This work should be performed by experienced personnel only.

Bore the cylinder with the most wear first to determine the proper oversize. If the cylinder will not clean up when bored for the maximum oversize piston recommended, the block should be replaced. Bore the cylinder to within approximately 0.0015 inch of the required oversize diameter. This will allow enough stock for the final step of honing the bores so the correct surface finish and pattern are obtained. Use a number 220-280 grit hone for this operation.

CAUTION: Thoroughly clean the block to remove all particles after the boring and honing operations, then coat the bores with oil.

(4) **CYLINDER BORE "GLAZE" REMOVAL.** Whenever piston rings are installed in a used cylinder, remove the "glaze" on the bore to aid in ring seating.

Take all necessary precautions to catch the grit. Pass a hone or glaze removing tool through the cylinder bore a few times. Do not hone more than enough to rough-up the finish. Thoroughly clean the cylinder bore and block after glaze removal, then oil the bores.

b. Pistons, Pins, and Rings.

(1) **CLEANING AND INSPECTION.** Remove the carbon deposits from the pistons. Clean the piston ring grooves with a ring groove cleaner (fig. 38). Make sure the oil ring slots (or holes) are clean.

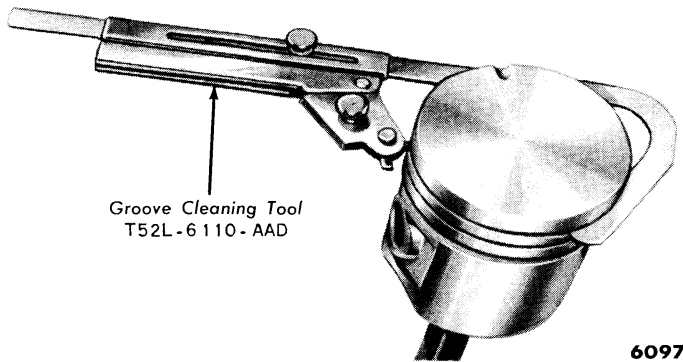

Fig. 38—Cleaning Ring Grooves

CAUTION: Do not use a caustic cleaning solution or a wire brush.

Inspect pistons for fractures at the ring lands, skirt, and pin bosses, and for scuffed or scored skirts. Spongy, eroded areas near the edge of the piston top are usually caused by detonation, or pre-ignition. A shiny surface on the thrust surface of the piston, offset from the centerline between the piston pin holes, can be caused by a bent connecting rod. The normal wear pattern of a piston is shown in fig. 39.

Inspect the piston pins for signs of fracture or etching. Check the pin for proper fit in the piston and rod bushing. Check for wear in the pin retainer grooves.

(2) **REPAIRS.** Replace pistons showing signs of excessive skirt clearance or ring side clearance, wavy ring lands, fractures or damage from detonation or pre-ignition.

Replace piston pins showing signs of fracture or etching. Piston pins that show wear or fit loosely in the piston or rod bushing should be replaced. Always replace all piston pin retainers.

(3) **FITTING PISTONS.** Pistons of 0.020, 0.030, 0.040 and 0.060 inch oversize are available for most engines. Check the parts catalogue for sizes available.

To fit a piston in a cylinder bore, calculate the size piston desired by taking a bore check (fig. 35) and select the proper size piston to provide the desired clearance. Check the piston being fitted by attaching a tension scale to the end of a feeler gauge ribbon ($\frac{1}{2}$ inch wide) of the proper thickness. Position the feeler on the side of the piston 90° from the piston pin hole. Invert the piston, then push the piston and feeler into the bore parallel to the crankshaft axis. Hold the piston and pull out the feeler ribbon, noting the reading on the pull scale (fig. 40).

If the scale reading is greater than the maximum allowable pull, recheck calculations to be sure that the proper size piston has been selected, check for a damaged piston, try a new piston, or hone the cylinder bore to obtain the proper fit.

If the scale reading is less than the minimum allow-

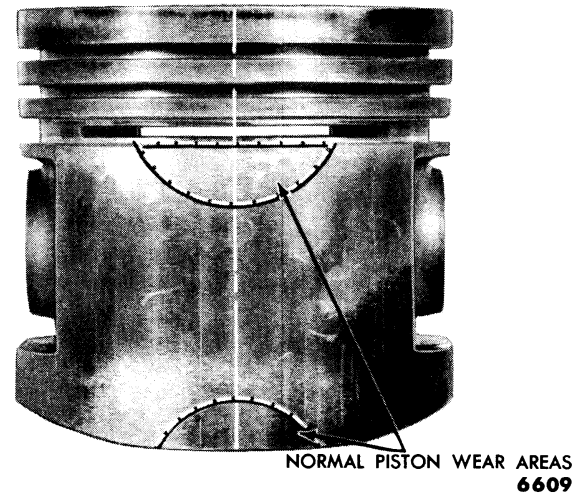

Fig. 39—Normal Wear Pattern

able pull, recheck calculations before trying another piston. If none can be fitted, hone the cylinder to the next size piston. When a piston has been fitted, mark it for assembly in the cylinder to which it was fitted.

NOTE: All pistons are the same weight, both standard and oversize; therefore, pistons of various sizes can be intermixed without upsetting engine balance. Rebore only the cylinder or cylinders which require it.

(4) **FITTING PISTON RINGS.** Select the proper ring set for the size piston to be used. Before the rings are installed on the piston, check each ring for proper gap as follows:

Position the ring in the cylinder bore in which it is

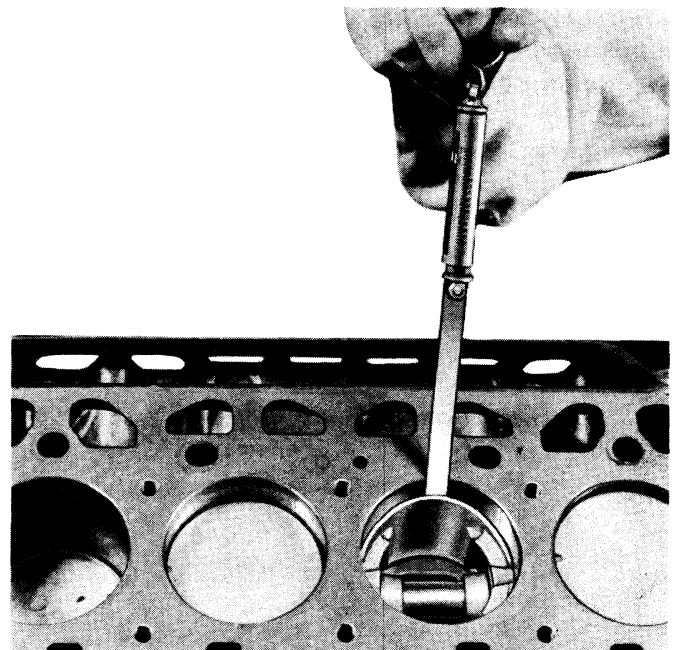

Fig. 40—Fitting Piston—Typical

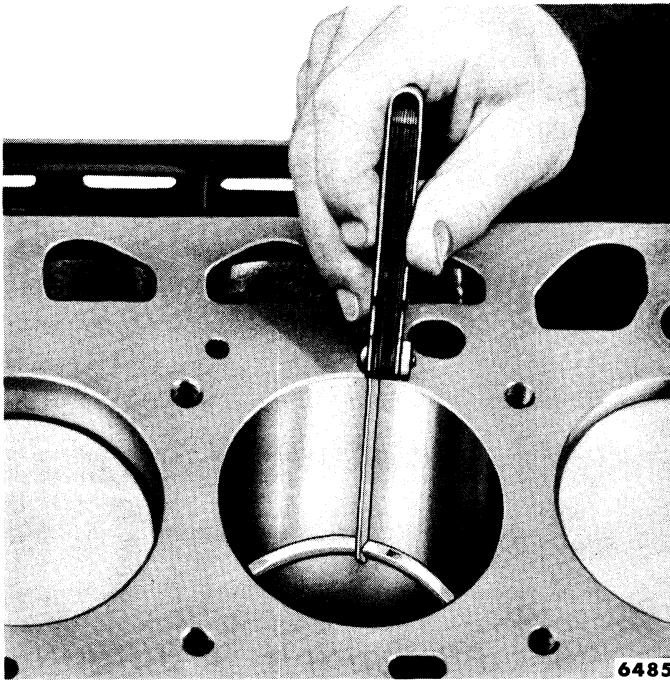
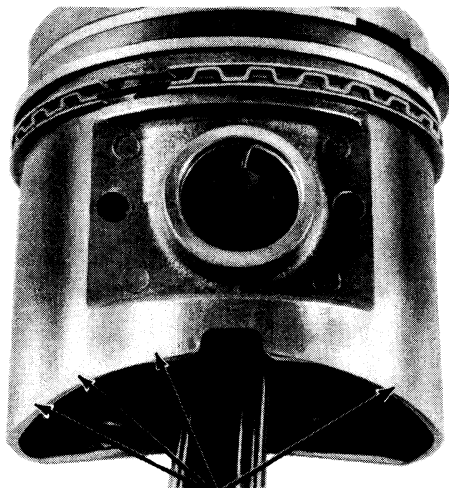

Fig. 41—Measuring Piston Ring Gap—Typical

going to be used. Push the ring down into the bore area where normal ring wear is not encountered. Use the head of a piston to position the ring in the bore so the ring is square with the cylinder wall. Use caution during this operation to avoid damage to the ring or cylinder bore. Measure the gap between the ends of the ring with a feeler gauge (fig. 41). The gap should be from 0.010-0.027 inch. If the gap is less than the lower limit, try another ring set. After the rings have been fitted in the cylinder bore, immediately install them on the piston, or identify them with the piston and cylinder in which they are to be installed.

After the rings have been installed in the ring grooves



PISTON WEAR CAUSED BY BENT ROD
OR MISALIGNED PISTON PIN HOLE

6371

Fig. 42—Wear Pattern on Piston—Piston Pin Boss Surface

according to the instructions on the piston ring package, check the ring side clearance with a feeler gauge. The gauge should slide freely around the entire piston ring circumference without binding.

If the rings are to be installed in a used cylinder, remove the “glaze” on the bore as previously explained.

(5) **FITTING PISTON PIN.** The piston pin fit should be a light thumb press fit at normal temperature (70° F). Standard piston pins are color coded green. Pins of 0.001 inch oversize (color coded blue) and 0.002 inch oversize (color coded yellow) are available.

If the piston pin hole must be reamed, use an expansion-type, piloted reamer. Place the reamer in a vise and revolve the piston around the reamer. Set the reamer to the size of the pin bore, then expand the reamer slightly and trial ream the pin bore. Take a light cut. Use a pilot sleeve of the nearest size to maintain alignment of the bores.

Check the reamed hole size, using the new piston pin. If the bore is small, expand the reamer slightly and make another cut. Repeat the procedure until the proper fit is obtained. Check the fitted piston pin for fit in the respective rod bushing. Ream the bushing if necessary to fit the pin.

Install the piston pin in the piston and rod. Install a retainer at each end of the pin to hold it in place. When the retainers are installed, make sure they are properly seated in the grooves provided in the piston pin bore. Always use new retainers.

c. Connecting Rod.

The connecting rods and related parts should be carefully inspected and checked for conformance to specifications. Various forms of engine wear which are caused by these parts can be readily identified as follows:

A shiny surface on the pin boss side of the piston usually indicates that a connecting rod is bent or the piston pin hole is not in proper relation to the piston skirt and ring grooves (fig. 42).

Abnormal connecting rod bearing wear can be caused by either a bent connecting rod, a crankshaft journal improperly machined, or a tapered connecting rod bore (fig. 43).

Twisted connecting rods will not create an easily identifiable wear pattern, but badly twisted rods will disturb the action of the entire piston, rings, and rod assembly that may result in excessive oil consumption.

(1) **CLEANING AND INSPECTION.** Clean all parts and passages in solvent. Never use a caustic cleaning solution. Remove the bearings (identify them if they are to be used again), then thoroughly clean the rod bore and the back of the bearings. For the different types of bearing failures and their causes, refer to Section 7. Make sure the oil squirt holes are open.

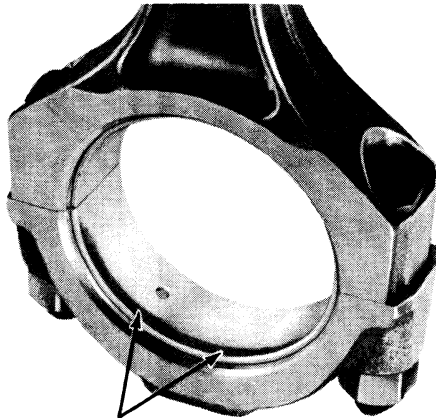

BEARING WEAR CAUSED BY BENT ROD OR
IMPROPER GRINDING OF CRANKSHAFT JOURNAL

6372

Fig. 43—Wear Pattern on Connecting Rod Bearing

Inspect the rods for deep nicks, signs of fractures, and check the bore for out-of-roundness.

Check the connecting rod bolts and nuts for damage.

After the connecting rods are assembled to the pistons, check the rods for bend or twist on a suitable alignment fixture. Follow the instructions of the fixture manufacturer.

(2) **REPAIRS.** If the piston pin to rod bushing clearance is excessive, ream the rod bushing and piston for the next oversize pin.

If the rod is twisted or bent more than specified, it should be straightened or replaced.

Replace defective connecting rod nuts and/or bolts.

Rods with deep nicks, signs of fractures, or with the bore out-of-round more than 0.0004 inch should be replaced.

d. Fitting Connecting Rod Bearings— Plastigage Method.

Place a piece of Plastigage on the bearing surface, the full width of the bearing, about ¼ inch off center. Install the cap and tighten the rod bolts to 45-50 foot-pounds torque.

NOTE: Do not turn the crankshaft with the Plastigage in place.

Remove the bearing cap, and use the Plastigage scale to measure the width of the flattened piece of plastic at the widest point.

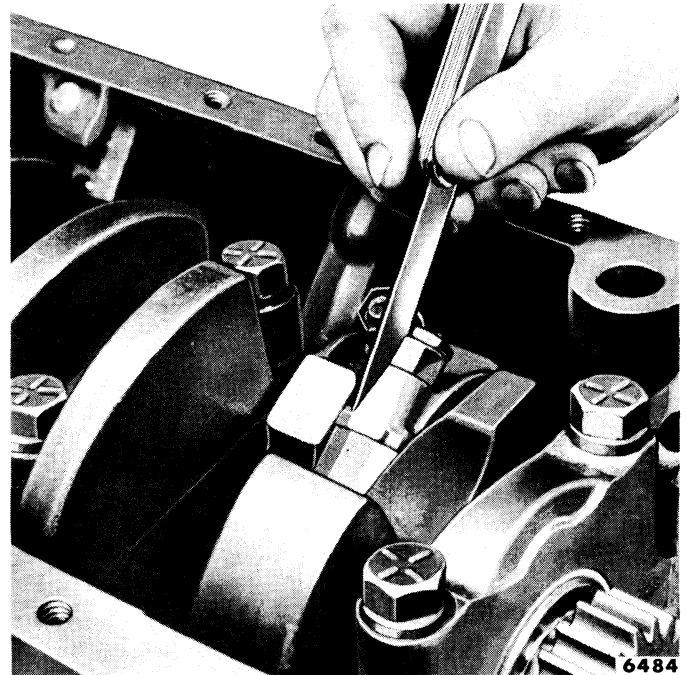

Fig. 44—Connecting Rod Side Clearance Check—Typical

NOTE: If the crankpin is out-of-round, be sure to fit the bearing to the maximum diameter of the crankpin. It is not recommended to use bearing shims of any type, or to file or lap the bearing caps in order to adjust the bearing clearance.

If the clearance is not satisfactory, try another selective fit bearing to bring to clearance within the desired limit.

NOTE: Red marked bearings increase the clearance, blue marked bearings decrease the clearance.

If the various selective fit bearings do not bring the clearance within the desired limit, it will be necessary to regrind the crankshaft journals and install undersize bearings.

Rotate the crankshaft after the bearing is installed to be sure the bearing is not too tight.

e. Connecting Rod Side Clearance.

After the connecting rods are installed, measure the side clearance with feeler stock (fig. 44).

9. OIL PAN AND OIL PUMP

a. Oil Pan.

Scrape any dirt or metal particles from the inside of the pan. Scrape all old gasket material from the gasket surface. Wash the pan in a solvent and dry it thoroughly. Be sure all foreign matter is removed from below the

baffle plate.

Check the pan for cracks, holes, damaged drain plug threads, a loose baffle, and a nicked or warped gasket surface.

Repair any damage, or replace the pan if repairs cannot be made.

Part ONE

POWER PLANT

Chapter

II

6-Cylinder Engine

Section	Page
1 Engine Steady Rest	31
2 Manifolds	32
3 Cylinder Head and Valves	33
4 Crankshaft Damper	36
5 Cylinder Front Cover and Crankshaft Oil Seal	36
6 Sprockets and Timing Chain, Camshaft and Bearings, and Tappets	37
7 Flywheel, Crankshaft, and Main Bearings	39
8 Connecting Rods and Bearings, Pistons, Pins, and Rings	42
9 Oil Pan, Oil Filter, and Oil Pump	44
10 Exhaust System	45

This chapter contains the removal, disassembly, assembly, and installation procedures for the component parts of the 6-cylinder engine.

The cleaning, inspection, and repair procedures for the component parts and engine overhaul instructions are covered in Chapter I, "General Engine Overhaul,

Inspection, and Repair." In addition, engine trouble shooting and tune-up are covered in Chapter I.

The 6-cylinder, EBP engine (fig. 1) has a bore of 3.62 inches, a stroke of 3.6 inches, and an 8.0:1 compression ratio.

This engine is available in all car models (except the Thunderbird).

I. ENGINE STEADY REST

The engine steady rest (fig. 2) does not support any engine weight and, as its name implies, it functions as a stabilizer only.

a. Removal.

Remove the two clamp bolts at the front of the steady

rest. Remove the spacer bolt that retains the insulators in the bracket. Remove the insulators. Remove the two bolts from the left side and the one bolt from the right side of the engine block, then remove the bracket assembly.

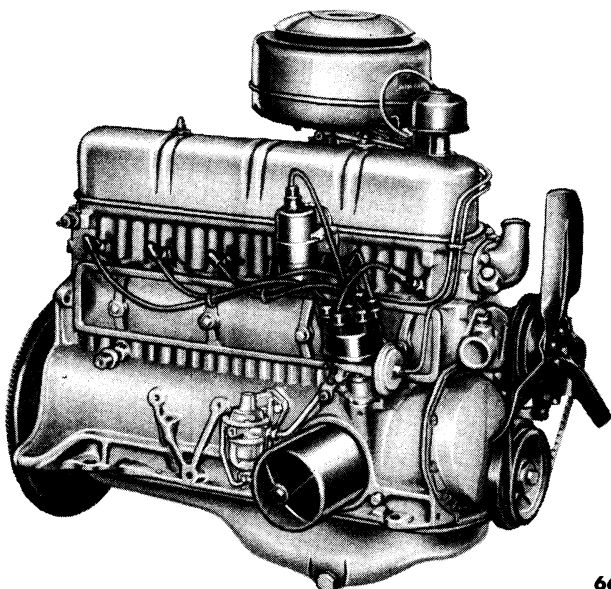

Fig. 1—223 Cubic Inch Engine— $\frac{3}{4}$ Right Front View

6615

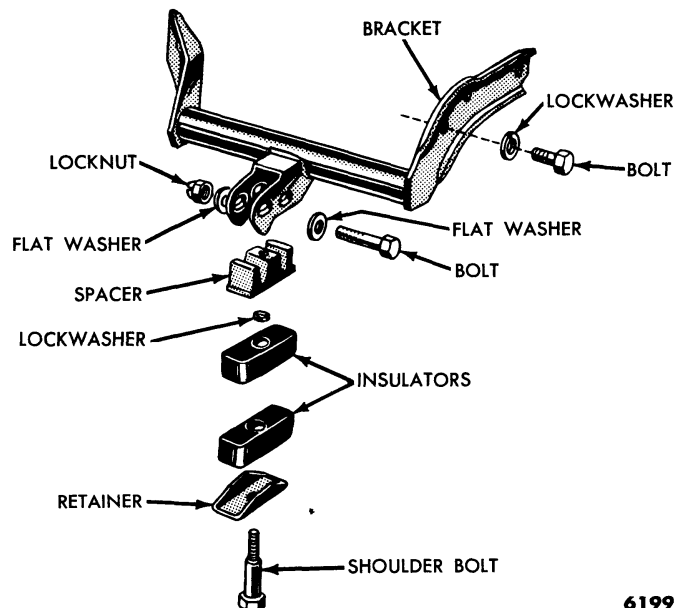

Fig. 2—Steady Rest Disassembled

6199

b. Installation.

Before installing the steady rest, inspect all the components for defects. Replace defective parts. Install the bracket on the cylinder block. Tighten the bolts to 23-28 foot-pounds torque. Install, but do not tighten, the insulators, spacer bolts, and clamp bolts. If necessary, cen-

ter the spacer bolt in the frame bracket by shifting the engine front mounts in their frame brackets. Then, tighten the spacer bolt to 20-25 foot-pounds torque. Make sure engine weight is not being transferred to the steady rest insulators, then tighten the clamp bolts to 25-30 foot-pounds torque.

2. MANIFOLDS

A chamber (heat riser) is cast into the intake manifold center section where the carburetor and exhaust manifold are attached. A thermostatically controlled valve, located in the exhaust manifold, directs exhaust gases into this area to provide the necessary heat required by the intake manifold to assist in vaporizing the incoming fuel mixture.

a. Removal.

Disconnect the throttle linkage at the manifold bell crank. Remove the air cleaner and the carburetor.

Disconnect the muffler inlet pipe. Remove the bolts fastening the manifold to the head, and lift the manifold assembly from the head. Remove the gaskets and sleeves. Remove the nuts and bolt joining the manifolds, then separate the manifolds. A disassembled view of the manifolds is shown in fig. 3.

b. Exhaust Gas Control Valve

The exhaust control valve is located in the outlet of

the exhaust manifold. Normally, it does not require replacement unless it becomes inoperative due to excessive corrosion or damage.

Before removing the valve assembly, note the position of the counterweight in relation to the valve plate. Remove the cotter pin, shield, washer, stop spring and thermostat spring from the front end of the shaft. Using an acetylene torch in the inside of the manifold, cut the shaft on both sides of the valve plate. Use caution to avoid damage to the shaft bearing bores. Remove the valve and shaft pieces. Clean the bearing bores of corrosion and repair any damage that may have occurred. Replace the bearings if necessary. Lubricate the new shaft and bearing bores with a penetrating oil or kerosene and graphite mixture. Insert the shaft through the bearings and valve plate. Rotate the shaft in the valve plate until the counterweight is in the normal "up" (heat on) position (fig. 4). Weld the valve to the shaft in the original manner. The shaft and valve are stainless steel to minimize corrosion and/or damage by excessive heat.

Install the thermostat spring in the shaft slot. Tighten the spring $\frac{3}{4}$ turn and hook the open end of the spring over the stop pin. The thermostat spring should hold the valve in the closed or "heat on" position (i.e. in the proper position to direct the flow of gases into the heat riser). Install the stop spring, shield, washer and cotter pin. Lubricate the shaft bearings while operating the valve manually to replace original lubricant lost through performing the welding operation.

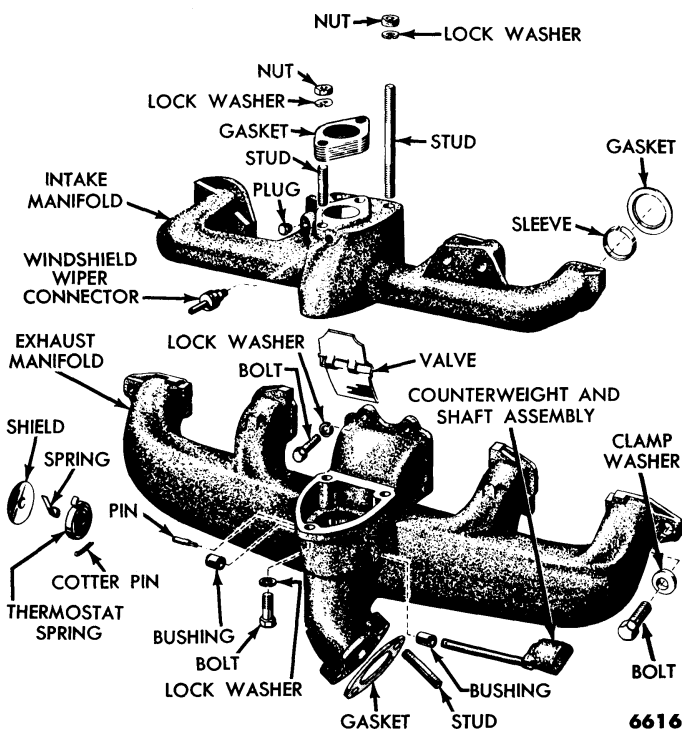

Fig. 3—Manifold Disassembled

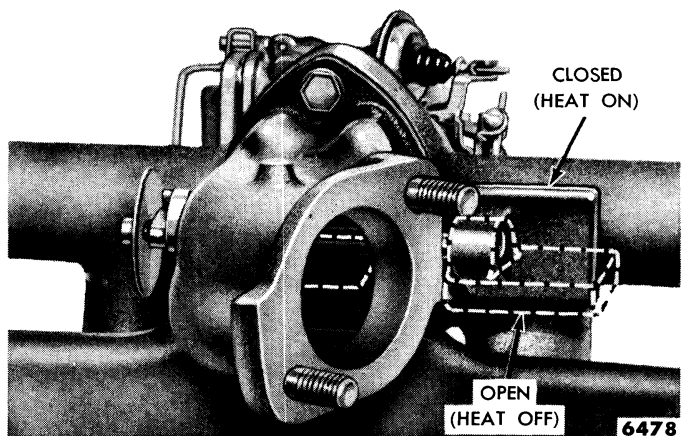

Fig. 4—Exhaust Control Valve

c. Installation.

Place the intake manifold over the studs on the exhaust manifold. Install the lock washers, nuts and bolt, then tighten them finger tight. Clean the mating surface of the cylinder heads. Inspect and repair any damage at the mating surfaces. Install new gaskets using new sleeves, if necessary, in the port of the cylinder head. Coat the mating surfaces lightly with graphite grease, then place the manifold assembly in position against the head.

NOTE: *Make sure the port openings in the manifold assembly are aligned with the port openings in the*

cylinder head and that none of the steel gaskets have become dislodged.

Tighten the bolts to 23-28 foot-pounds torque, tightening from the center to the ends. Tighten the bolt and nuts joining the intake and exhaust manifolds to 23-28 foot-pounds torque. Install a new exhaust outlet flange gasket, and position the muffler inlet pipe over the studs. Install the nuts and lockwashers, then tighten the nuts to 23-28 foot-pounds torque.

Connect the throttle linkage. Install the carburetor and connect the carburetor linkage. Install the air cleaner.

3. CYLINDER HEAD AND VALVES

The cylinder head carries the valves and valve rocker arm mechanism, the manifold assembly, ignition coil, and the water outlet.

Valve guides are an integral part of the cylinder head. Both the intake and exhaust valve assemblies are the rotating-type which incorporate umbrella-type valve stem seals.

a. Cylinder Head Removal.

Drain the cooling system. Remove the radiator upper hose and heater hose. Remove the air cleaner, then tape the carburetor air horn closed. Disconnect the battery cable at the cylinder head. Disconnect the windshield wiper vacuum line, accelerator rod, choke cable, temperature sending unit wire, and oil pressure sending unit wire.

Disconnect the coil from the head and move it to one side. Remove the spark plug wires and remove the spark plugs.

Disconnect the fuel line at the carburetor and the fuel pump. Disconnect the distributor vacuum line at the carburetor and the distributor. Disconnect the manifold vacuum line at the manifold and at the booster pump, then remove the three lines as an assembly.

Remove the rocker arm cover. Remove the cap screw and clip from the number 6 rocker arm support bracket. Pull the oil feed line out of the bracket, then pull it out of the block with pliers (fig. 5). Be careful not to damage the line.

Loosen all rocker arm adjusting screws to remove the valve spring load from the rocker arms, then remove the rocker arm shaft assembly.

Remove the valve push rods in sequence. Identify them so they can be installed in their original positions (fig. 6).

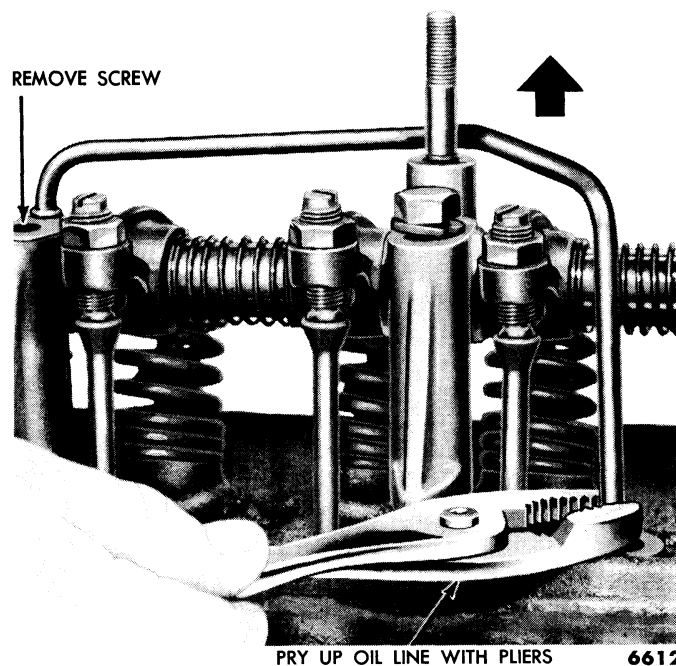

Fig. 5—Oil Line Removal

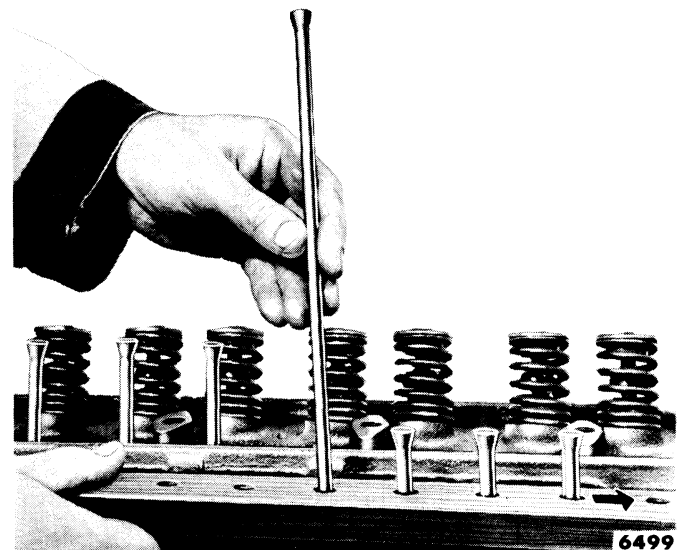

Fig. 6—Valve Push Rod Removal

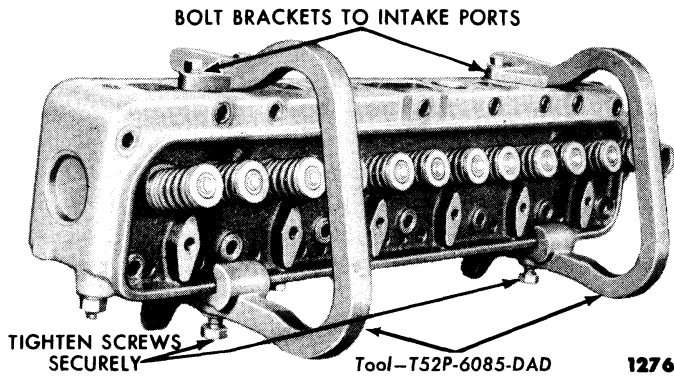

Fig. 7—Cylinder Head Holding Fixture

Remove the manifold to head bolts, and pull the manifold assembly away from the head. Brace the assembly so the inlet pipe will not be damaged.

Install the cylinder head holding fixtures for convenience in lifting the head and to protect the gasket surfaces (fig. 7).

Remove all cylinder head bolts. Install the cylinder head guide studs (fig. 8). Lift the cylinder head assembly off the engine.

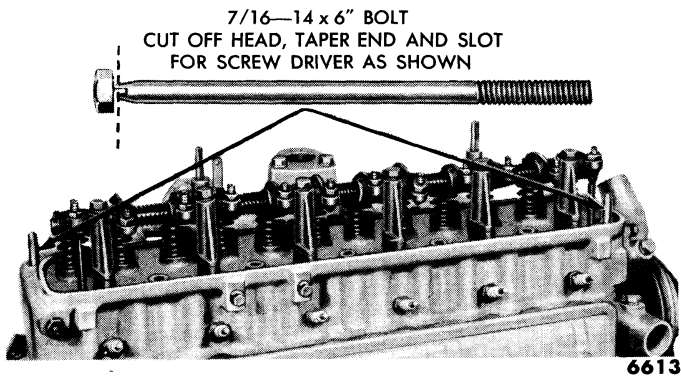

Fig. 8—Cylinder Head Guide Studs

CAUTION: Do not pry between the head and block as the gasket surfaces may become damaged.

b. Rocker Shaft Disassembly.

Pull the oil drain line and clip out of the number 1

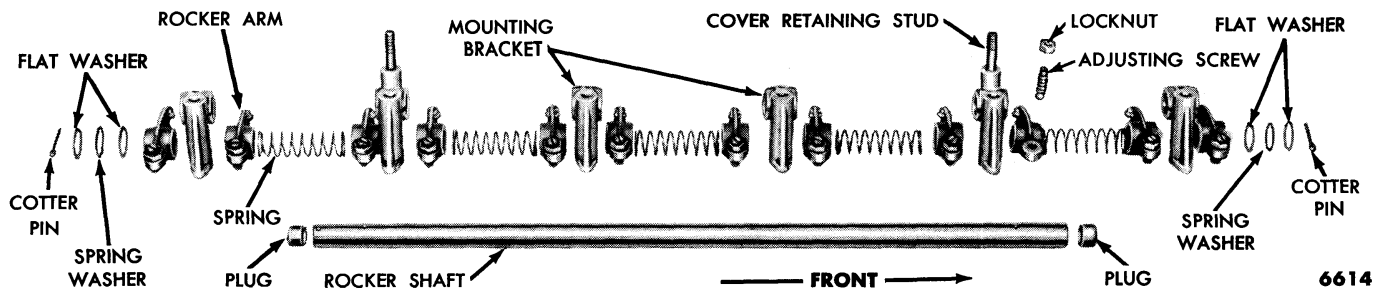

Fig. 10—Rocker Mechanism Disassembled

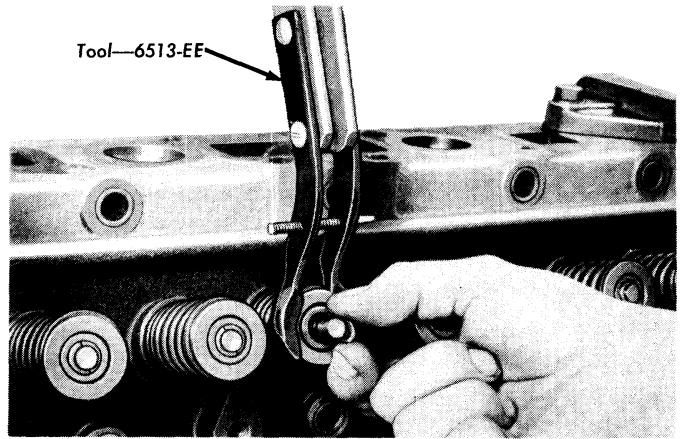

Fig. 9—Valve Stem Lock Removal or Installation

support bracket. Remove the cotter pins at each end of the rocker arm shaft, and remove the flat washers and spring washers. Remove the plugs at each end of the shaft.

NOTE: The plugs are an interference fit. To remove the plugs, drill or pierce the plug on one end, then use a steel rod to knock out the plug on the opposite end. Working from the open end, knock out the remaining plug.

Slide the rocker arms, springs, and brackets off the shaft. Be sure to identify the parts.

c. Cylinder Head Disassembly.

Clean the carbon out of the combustion chambers before removing the valves. Compress the valve springs (fig. 9), then remove the valve retainer locks and release the spring. Remove the sleeve, spring retainer, spring, stem seal, and valve.

Discard the valve stem seals. Identify all valve parts.

d. Rocker Shaft Assembly.

Oil all moving parts with engine oil. Using a blunt tool or large diameter pin punch, install a plug, cup side out, in each end of the rocker shaft. Install a flat

washer, spring washer, another flat washer, and a cotter pin on one end of the shaft. Install the rocker arms, support brackets, and springs in the order shown in fig. 10. Complete the assembly by installing the remaining flat washers with the spring washer between them, and install the cotter key.

e. Cylinder Head Assembly.

Install each valve in the port from which it was removed or to which it was fitted. Install a new stem seal on the valve. Install the valve spring with the closed coil against the head surface, then install the valve spring retainer, and sleeve. Compress the spring, and install the retainer locks (fig. 9).

Measure the valve spring assembled height from the machined surface of the cylinder head spring pad to the spring retainer contact surface as shown in fig. 11. If the assembled height is $1\frac{13}{16}$ inches or greater, install the necessary 0.030 inch thick spacer and/or spacers between the cylinder head valve spring pad and the valve spring to bring the assembled height to the recommended dimension of $1\frac{25}{32}$ - $1\frac{13}{16}$ inches.

CAUTION: *Do not install spacers unless necessary. Use of spacers in excess of recommendations will result in overstressing the valve springs which will lead to excessive load loss and spring breakage.*

f. Cylinder Head Installation.

Clean carbon deposits and gasket sealer residue from the head and block gasket surfaces. Inspect the head for any damage and repair as necessary. Apply a coating of cylinder head gasket sealer to both sides of a new gasket. Use the brush furnished to spread the sealer evenly over the entire gasket surface. Position the gasket over the guide studs on the cylinder block. Lift the cylinder head over the guides and slide the head down carefully. Before installing the cylinder head bolts, coat the threads of each bolt with a small amount of water resistant sealer. Install two bolts at opposite ends of the head to hold the head and gasket in position. Remove the guides, then install the remaining bolts. Remove the cylinder head holding fixtures. The cylinder head bolt tightening procedure is performed in three progressive steps. First, tighten the bolts to 55 foot-pounds torque (cold) in the sequence shown in fig. 12, then tighten them to 65 foot-pounds torque (cold) in the same sequence. Install the push rods in their proper sequence. Position the lower end of the rods in the tappet sockets. Position the valve rocker arm assembly on the head, then install the oil drain line, clip, and retaining screw on the number 1 bracket. Make sure the oil line enters the shaft locating hole. Position the oil feed line on the

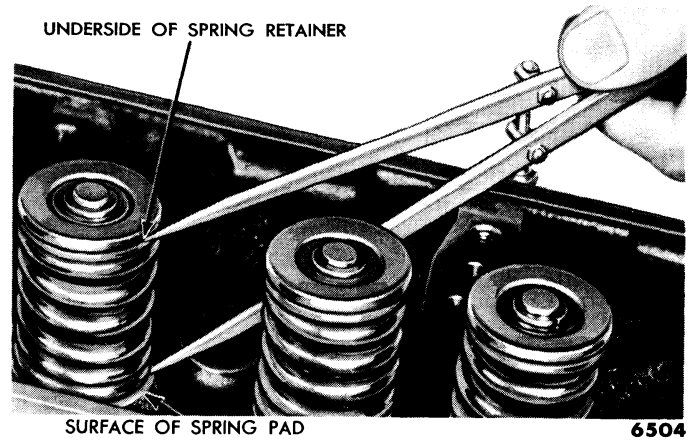

Fig. 11—Checking Valve Spring Assembled Height—Typical

number 6 bracket. Make sure the lower end of the oil line "O" ring seal is in the oil supply counterbore, then install the bolt. Tighten all the retaining bolts to 45-55 foot-pounds torque. Perform a preliminary (cold) valve lash adjustment.

Install the manifold assembly, the ignition coil, and spark plugs. Connect the spark plug wires and the temperature sending unit wire. Connect the radiator upper hose and the heater hoses. Install the accelerator pedal rod. Position the two vacuum lines and the fuel line on the engine, then connect the lines. Connect the windshield wiper hose. Connect the battery cable to the head. Fill the cooling system. Remove the tape from the carburetor air horn, then connect the choke wire. Start the engine and run it for a minimum of 30 minutes at approximately 1200 r.p.m. With the engine warmed up, tighten the cylinder head bolts, in proper sequence, to 75 foot-pounds torque (hot), then check the valve lash with the engine idling and adjust it if necessary.

NOTE: *After the cylinder head bolts have been tightened to specifications, the bolts should not be disturbed.*

Coat one side of the rocker arm cover gasket with oil resistant sealer, and lay the cemented side of the gasket in place in the cover. Install the rocker arm cover, making sure that the gasket seats evenly all around the head. Install the rubber seals on the studs making sure they are centered in the cover openings. Tighten the retaining nuts to 2.0-2.5 foot-pounds torque.

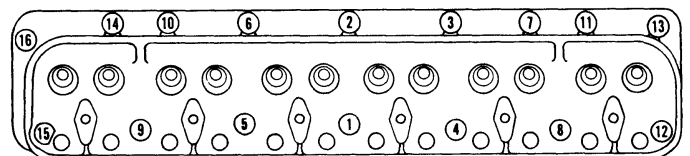

Fig. 12—Cylinder Head Bolt Tightening Sequence

4. CRANKSHAFT DAMPER

A single sheave crankshaft damper and pulley assembly is standard. The assembly is keyed to the crankshaft and retained with a cap screw and washer. Two threaded holes are provided in the damper to facilitate removal.

On cars equipped with power steering, an additional single sheave pulley is bolted to the crankshaft damper to drive the power steering pump.

a. Removal.

Remove the radiator. Remove the drive belts.

On cars equipped with power steering, remove the two bolts and lockwashers that fasten the power steering pump pulley to the crankshaft damper and remove the pulley.

Remove the cap screw and washer from the end of

the crankshaft. Install the tool shown in fig. 13 and remove the damper.

b. Installation.

Lubricate the crankshaft with an oil and white lead mixture and lubricate the oil seal rubbing surface with grease. Align the damper keyway with the key on the crankshaft, and start the damper on the shaft. Press the damper on the shaft (fig. 14). Install the lockwasher and capscrew, then tighten the bolt to 85-95 foot-pounds torque. Install and adjust the generator belt.

On cars equipped with power steering, install the power steering pump pulley on the crankshaft damper. Tighten the retaining bolts to 23-28 foot-pounds torque. Install and adjust the power steering pump belt.

Install the radiator.

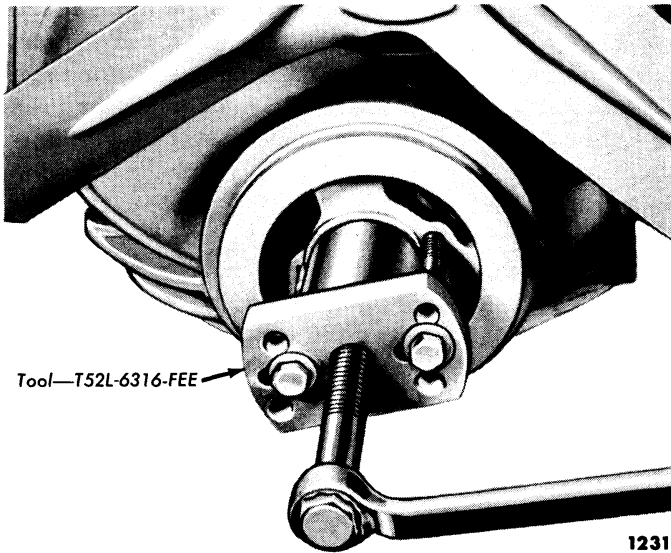

Fig. 13—Damper Removal

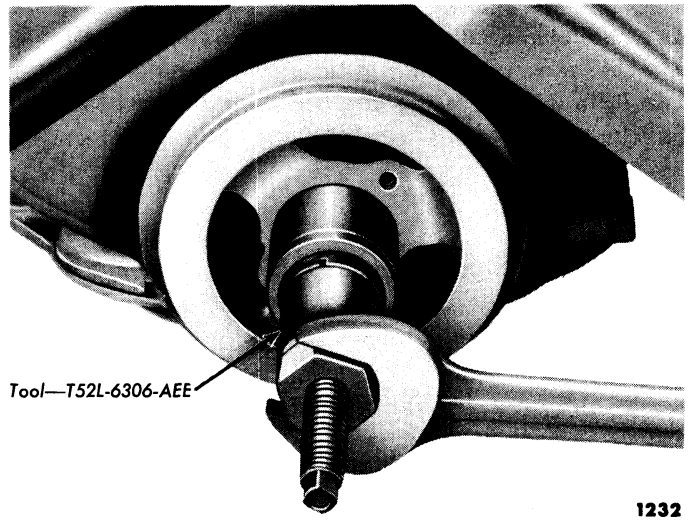

Fig. 14—Damper Installation

5. CYLINDER FRONT COVER AND CRANKSHAFT OIL SEAL

The cylinder front cover is fastened to the cylinder block by ten pan head screws and to the oil pan by two hex head bolts. Two dowels are used to locate the cover on the block. The ignition timing pointer is welded to the cover.

NOTE: *It is good practice to replace the front oil seal each time the cylinder front cover is removed.*

a. Cylinder Front Cover Removal.

Remove the radiator, the crankshaft damper, and the oil pan. Remove the cover retaining screws, the cover, and the gasket.

b. Oil Seal Replacement.

Drive out the old seal with a pin punch, then clean out the recess in the cover. Coat a new seal with grease,

then install the seal (fig. 15). Drive the seal in until it is fully seated in the recess. Check the seal after installation to be sure the spring is properly positioned in the seal.

c. Cylinder Front Cover Installation.

Clean the cylinder front cover and the gasket surface of the cylinder block. Coat the gasket surface of the block and the cover with sealer, then position a new gasket on the block. Place the cover on the block and install the retaining screws. Tighten the screws to 6-9 foot-pounds torque. Install the oil pan. Install the crankshaft damper and belt.

On cars equipped with power steering, install the power steering pump pulley and belt.

Install the radiator.

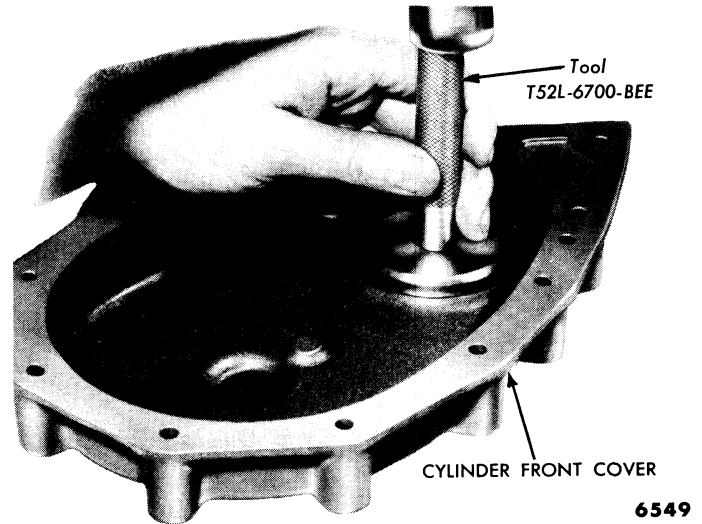

Fig. 15—Oil Seal Installation—Typical

6. SPROCKETS AND TIMING CHAIN, CAMSHAFT AND BEARINGS, AND TAPPETS

The camshaft is supported by four steel-backed babbitt insert-type bearings pressed into the block. It is driven by a sprocket and timing chain in mesh with a sprocket on the crankshaft. Camshaft thrust is controlled by a spacer and a thrust plate located between the camshaft sprocket and the shoulder on the camshaft. The plate is bolted to the front of the block. An eccentric, made integral with the camshaft, operates the fuel pump.

The removal and installation procedures given below are applicable when the engine is stalled in the car. If the engine is removed, eliminate any steps not applicable.

a. Sprockets and Timing Chain.

The camshaft sprocket is a slip fit on, and is keyed to, the end of the camshaft.

(1) **REMOVAL.** Remove the radiator and the cylinder front cover. Crank the engine until the timing marks on the sprockets and chain are positioned as shown in fig. 16.

Remove the camshaft sprocket retaining bolt and washer. Slide both sprockets and the timing chain forward and remove them as an assembly.

(2) **INSTALLATION.** Place the keys in position in the slots on the crankshaft and camshaft. Position the sprockets and timing chain on the camshaft and crankshaft. Be sure the timing marks on the sprockets and chain are positioned as shown in fig. 16. There are 12 timing chain link pins between the timing marks on the sprockets.

Install the camshaft sprocket washer and retaining

bolt. Tighten the bolt to 45-50 foot-pounds torque.

Install the cylinder front cover, crankshaft damper, belt, and radiator.

On cars equipped with power steering, install the power steering pump pulley and belt.

b. Camshaft.

The camshaft and related parts are shown in fig. 17.

(1) **REMOVAL.** Remove the radiator support bar, radiator, and the radiator grille assembly, cylinder front cover, and oil pan.

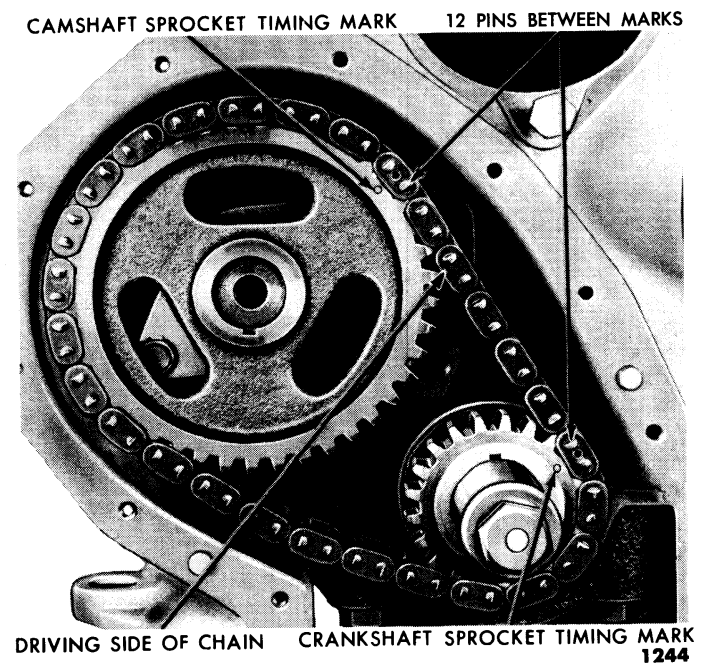
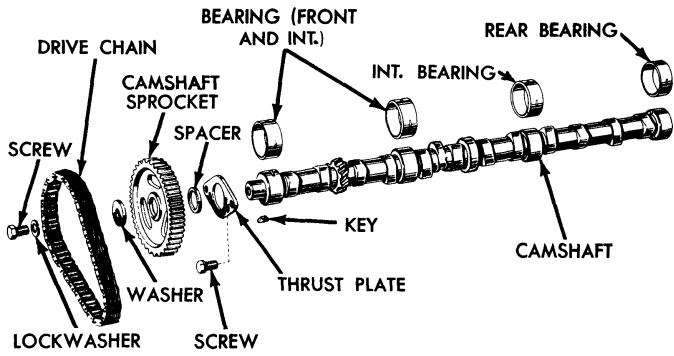

Fig. 16—Aligning Timing Marks



6298

Fig. 17—Camshaft and Related Parts

Remove the rocker arm cover. Disconnect the ignition switch to coil wire from the engine clips, then remove the push rod chamber cover. Remove the rocker arm assembly, then remove the valve push rods in sequence.

Remove the camshaft sprocket bolt. Crank the engine until the timing marks on the sprocket and chain are positioned as shown in fig. 16. Remove the distributor cap, and scribe a line on the distributor housing and cylinder block to mark the position of the rotor and distributor housing for installation, then remove the distributor.

Remove the sprockets and timing chain. Remove the camshaft thrust plate, woodruff key, and spacer.

Turn the camshaft until the tappets can be lifted with either a magnet (fig. 18), or the fingers. Raise the tappets clear of the camshaft lobes, and secure them with spring-type clothes pins or window regulator spring clips (figs. 18 and 19).

Carefully remove the camshaft by pulling it toward the front of the engine.

CAUTION: Exercise the necessary caution to avoid damaging the camshaft bearings.

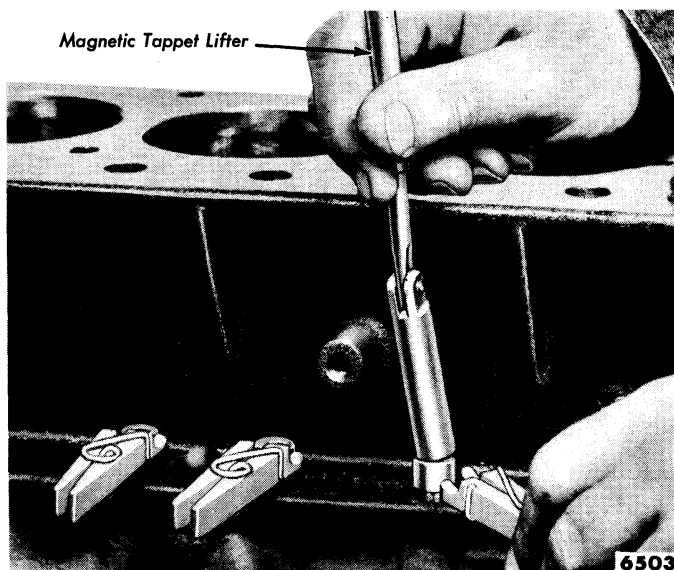

Fig. 18—Lifting and Securing Valve Tappets

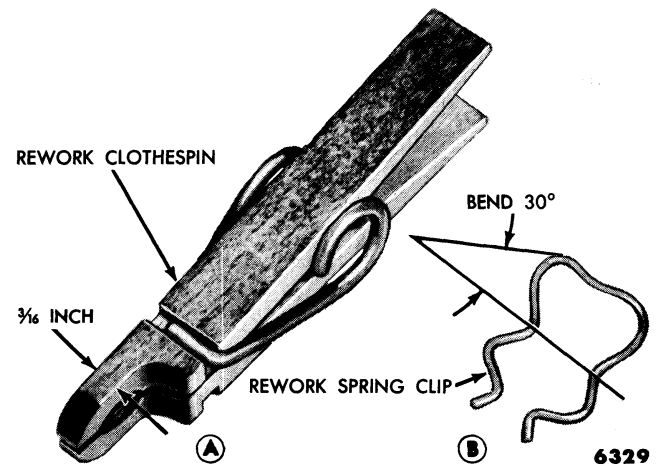

Fig. 19—Tappet Retainers

(2) **INSTALLATION.** Oil the camshaft and carefully slide it through the bearings. Install the thrust plate and spacer.

NOTE: Be sure the chamfer on the inside of the spacer is to the rear or faces the camshaft journal when the spacer is installed.

Tighten the retaining bolts to 12-15 foot-pounds torque. Install the woodruff key in the camshaft.

Check the camshaft end play. If the end play is excessive, inspect the spacer for correct installation. Replace the thrust plate and/or spacer if necessary. Install the sprockets and timing chain, camshaft sprocket washers and bolt, cylinder front cover, crankshaft damper, drive belts, and oil pan.

Install the hub and fan blades, fuel pump, radiator, radiator support bar, and radiator grille.

Release the tappets and install the push rods, then install the rocker arm assembly.

Install the distributor, using the scribed lines as guides to properly position the rotor and housing; make a preliminary valve lash adjustment. Install the distributor cap and carburetor air cleaner. Cement the gasket to the push rod chamber cover and install the cover. Tighten the retaining screws to 15-20 inch-pounds torque.

Run the engine at fast idle and check for oil and coolant leaks. Make a final (hot) valve lash adjustment with the engine idling. Install the rocker arm cover. Check the ignition timing and adjust the timing if necessary.

c. Tappet Replacement.

Remove the camshaft as outlined in "b." Remove and install one tappet at a time through the bottom of the block. A flexible-type holding tool can be used if desired.

As each tappet is installed, it should be secured in the up position.

After the tappets are installed, install the camshaft as outlined in "b."

d. Bearing Replacement.

It will be necessary to remove the engine from the car to replace camshaft bearings. The bearings are available pre-finished to size and require no reaming for standard and 0.015 inch undersize journal diameters. Number 3 bearing is not interchangeable with the other bearings.

Remove the camshaft as outlined in "b." Remove the flywheel and crankshaft. Push the pistons to the top of the cylinders to move the connecting rods out of the way. Knock out the camshaft rear bearing bore plug working from the front bearing bore, or drill a 1/2 inch hole in the plug and use the tool shown in fig. 20 to remove the plug. Remove the camshaft bearings with the tool shown in fig. 21.

Position the bearing at the bearing bore, and press it in place with the tool shown in fig. 21. Number 1 cam bearing must be pressed in 0.005-0.025 inch below the front face of the bearing bore. Press the remaining bearings in sufficiently to align the oil supply holes.

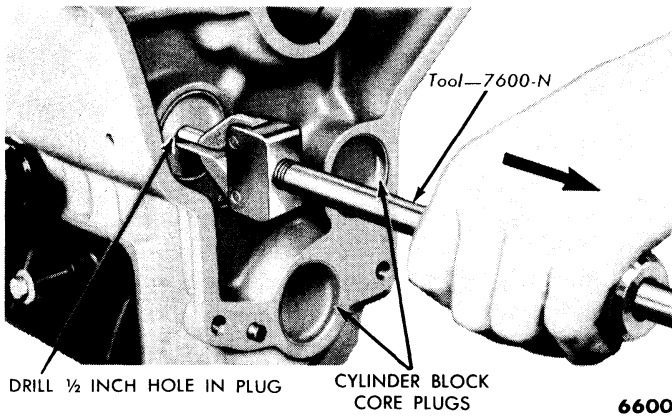

Fig. 20—Camshaft Bore Plug Removal

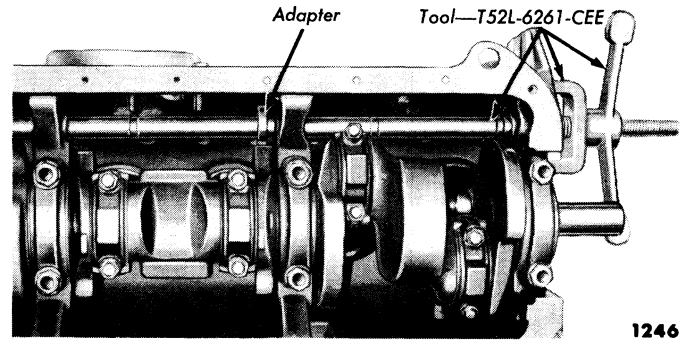

Fig. 21—Camshaft Bearings—Removal or Installation

Clean out the plug recess in the camshaft rear bore. Lightly coat the outer rim of a new plug with sealer. Install the plug with the tool shown in fig. 22.

Install the camshaft as outlined in "b." Install the crankshaft and flywheel, then install the engine in the car.

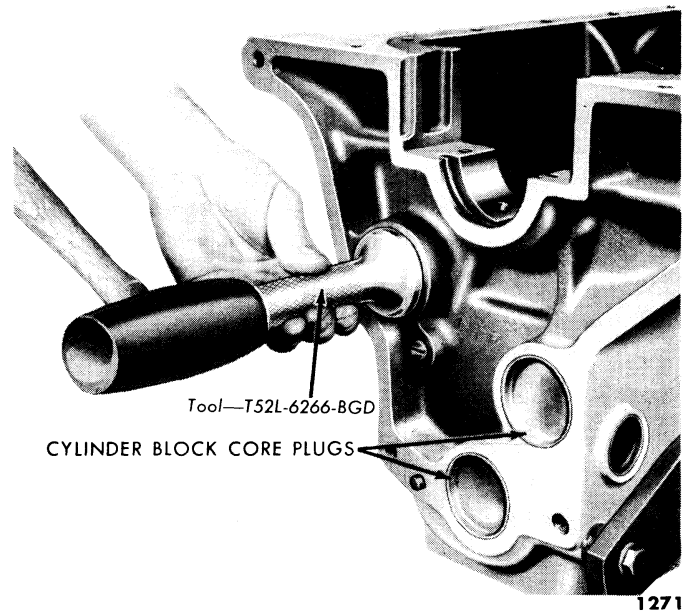

Fig. 22—Camshaft Bore Plug Installation

7. FLYWHEEL, CRANKSHAFT, AND MAIN BEARINGS

The crankshaft and related parts are shown in fig. 23. The procedure for replacing the clutch pilot bushing is covered in Part TWO.

a. Flywheel.

The flywheel is piloted on a shoulder and is retained on the crankshaft by six bolts. The flywheel can be bolted to the crankshaft in only one position as the bolt holes are unequally spaced. The ring gear is a shrink fit on the flywheel.

On cars equipped with a standard or overdrive transmission, the rear face of the flywheel is used as a friction surface which is engaged by the clutch disc. The flywheel can be removed and installed with the engine mounted in the car.

The flywheel used on Fordomatic equipped cars has two laminated spring-steel drive plates riveted to the outer edge 180° apart, to which the converter cover is attached.

(1) REMOVAL — STANDARD OR OVERDRIVE

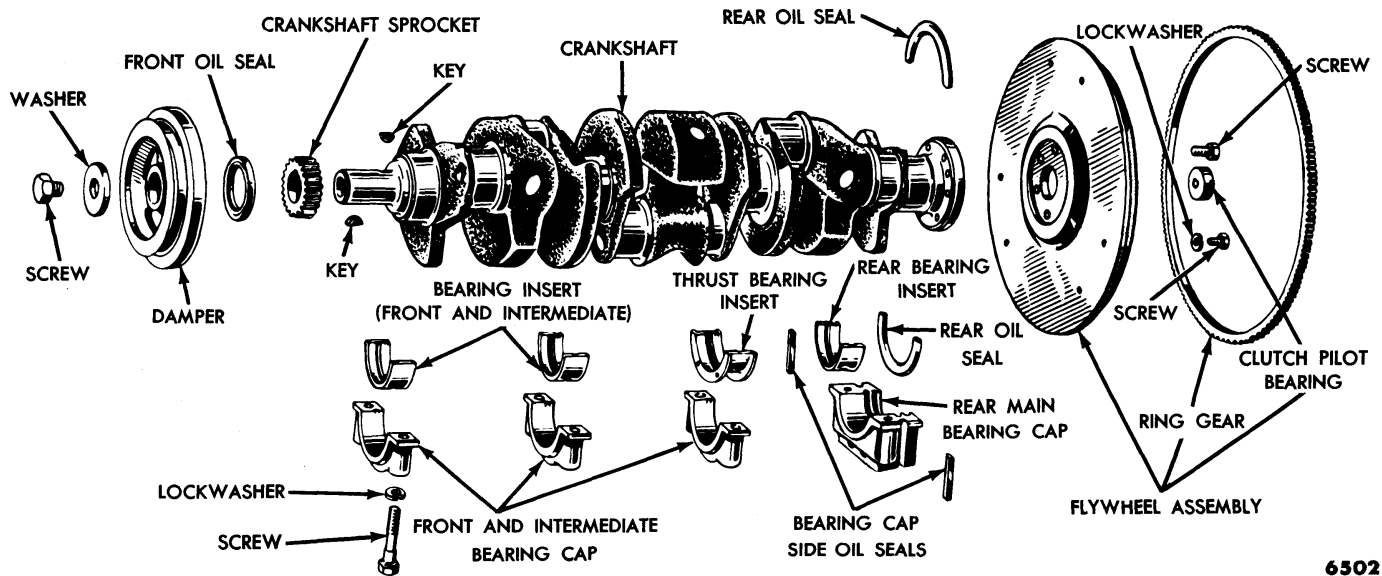

Fig. 23—Crankshaft and Related Parts

6502

TRANSMISSION. Remove the transmission. Remove the flywheel housing dust cover. Mark the clutch assembly so it can be replaced in the same position. Remove the clutch release rod, spring, and bearing. Remove the clutch pressure plate and disc (Tool-7563). Remove the flywheel retaining bolts and pry the flywheel off the crankshaft. Remove the flywheel through the housing lower access opening.

CAUTION: Do not get grease or oil on the clutch components.

(2) **INSTALLATION — STANDARD OR OVER-DRIVE TRANSMISSION.** Position the flywheel on the crankshaft flange and align the bolt holes, then install the mounting bolts. Tighten the bolts in sequence across from each other to 75-85 foot-pounds torque. Using a pilot shaft (Tool-6392-N) to locate the clutch disc, install the pressure plate and disc. Install the clutch release rod, bearing, spring, and hub. Install the flywheel housing dust cover. Install the transmission.

(3) **REMOVAL—FORDOMATIC.** Remove the two rubber plugs from the floor pan, then remove the converter housing to engine block upper bolts. Raise the front of the car and position safety stands. Remove the transmission control linkage shield, the torque converter lower access plate, the torque converter air inlet shield, and the torque converter front access plate. Turn the torque converter until the drain plug is at the lower edge. Drain the transmission and torque converter.

Remove the drive shaft. Disconnect the speedometer cable and transmission control rod at the transmission. Remove the battery cable from the starter, then remove the starter. Remove the transmission oil level indicator tube.

Install the drain plug in the torque converter. Posi-

tion a jack under the transmission. Remove the transmission support bolts. Remove the frame cross member at the rear of the transmission. Remove the two lower bolts securing the torque converter housing to the engine block. Move the transmission back far enough to clear the flex drive plate. Secure the torque converter to the housing.

CAUTION: If the torque converter is not secured, it will slide off the splines.

Remove the flex drive plate from the crankshaft.

(4) **INSTALLATION—FORDOMATIC.** Position the flex drive plate on the crankshaft and align the bolt holes, then install the mounting bolts. Tighten the bolts to 75-85 foot-pounds torque. Align the converter pilot and the housing dowel holes, then install the torque converter housing to engine block lower bolts. Install the flex plate to converter bolts. Install the frame cross member. Remove the jack. Install the transmission rear support bolts.

Connect the transmission throttle control linkage, the manual control linkage, and the speedometer cable. Install the torque converter air inlet shield, control linkage shield, torque converter housing front access cover, the torque converter lower access cover, and the transmission oil level indicator tube.

Install the starter, then connect the battery cable to the starter. Install the drive shaft. Remove the safety stands and lower the car. Install the converter housing to engine block bolts. Install the rubber plugs and position the floor mat.

Fill the transmission with fluid. Start the engine to fill the torque converter, then add fluid until the proper level is reached on the oil level indicator. Check for

leaks. Check and adjust the manual control, the neutral switch, and the throttle linkage.

b. Crankshaft.

The crankshaft is precision-molded, alloy iron with integral counterweights and is statically and dynamically balanced. Oil distribution holes are drilled through the shaft to pressure lubricate the main and connecting rod bearings.

NOTE: *Handle the crankshaft with care to avoid possible fractures or damage to the finished surfaces.*

(1) **REMOVAL.** Remove the engine and install it on a work stand. Remove the flywheel housing, clutch assembly, flywheel or flex drive plate, and the engine rear plate. Mark the clutch pressure plate assembly so it can be installed in the same position on the flywheel. Remove the crankshaft damper, cylinder front cover, sprockets and timing chain. Remove the oil pan and the oil pump screen housing assembly.

Make sure all bearing caps (main and connecting rod) are marked so they can be installed in their original locations. Remove the connecting rod bearing caps, using care not to intermix the caps, then push the pistons to the top of the cylinders.

Remove the main bearing caps, and mark them for installation on the same journals. Carefully lift the crankshaft out of the block so the thrust bearing surfaces are not damaged. Remove the rear journal oil seal from the block and rear bearing cap, and remove the cap to block side seals.

(2) **INSTALLATION.** Be sure the bearings and the crankshaft journals are clean. Install a new rear journal oil seal in the block and rear main bearing cap. Carefully lower the crankshaft into place.

CAUTION: *Be careful not to damage the bearing surfaces.*

Check the clearance of each main bearing using Plastigage (Chapter I). After the clearance has been checked and found to be satisfactory, apply a light coat of engine oil to the journals and bearings, then install all the bearing caps except the thrust bearing cap. Install new side seals when the rear main bearing cap is installed. Install the thrust bearing cap and draw the cap bolts up lightly, then align the thrust bearing (Chapter I). Tighten the cap bolts to specifications. Check the crankshaft end play (Chapter I).

Install the connecting rod caps in their original positions. Check the bearing clearance, using Plastigage (Chapter I). After the clearance has been checked and found to be satisfactory, apply a light coat of engine oil to the journals and bearings, then install the rod

caps. Tighten the nuts to 45-50 foot-pounds torque. Install the pal nuts and tighten them to 3-4 foot-pounds torque. Check the end play of each connecting rod (Chapter I).

Install the engine rear plate. Install the flywheel or flex drive plate. Align the clutch disc (Tool-6392-N), compress the clutch pressure plate springs, and install the pressure plate assembly. Install the flywheel housing. Install the sprockets and timing chain. Install the cylinder front cover, oil pump screen assembly and oil pan, the crankshaft damper, and belt.

On cars equipped with power steering, install the power steering pump pulley and belt.

Install the engine in the car. Fill the crankcase, then start the engine and check for oil pressure and oil leaks.

c. Main Bearings.

The main bearings are the steel-backed, copper-lead, or lead-babbitt insert-type.

Crankshaft end play is controlled by the number 3 main bearing flanges.

If the crankshaft has been removed, new bearings can be readily fitted. However, the bearings can be fitted with the engine in the chassis as follows:

Remove the oil pan, then remove the oil pump.

NOTE: *Replace one bearing at a time, leaving the other bearings securely fastened.*

Remove the main bearing cap to which new bearings are to be fitted. Insert the upper bearing removal tool (Tool 6-331) in the oil hole in the crankshaft. Rotate the crankshaft in the opposite direction to engine rotation to force the bearing out of the block.

NOTE: *When replacing standard bearings with new bearings, it is good practice to first try to obtain the proper clearance with two blue bearing halves.*

To install the upper main bearing, place the plain end of the bearing over the shaft on the locking tang side of the block. Using the same tool, rotate the crankshaft in the direction of engine rotation until the bearing seats itself. Remove the tool. Replace the bearing cap.

Clean the crankshaft journal and bearings. Check the bearing clearance using Plastigage (Chapter I). After the clearance has been checked and found to be satisfactory, apply a light coat of engine oil to the journals and bearings, then install the bearing cap. Tighten the bolts to 95-105 foot-pounds torque.

If the rear main bearing is replaced, replace the journal oil seals and the side seals.

Install the oil pump and oil pan. Fill the crankcase, then start the engine and check for oil pressure and oil leaks.

8. CONNECTING RODS AND BEARINGS, PISTONS, PINS, AND RINGS

The piston and connecting rod are shown disassembled in fig. 24.

a. Piston and Connecting Rod Removal.

Remove the oil pan and cylinder head. Before removing the piston assemblies, remove any ridge and/or carbon deposits from the upper end of the cylinder bores. Move the piston to the bottom of its travel and place a cloth on the piston head to collect the cuttings. Remove the cylinder ridge with a ridge cutter. Follow the instructions furnished by the tool manufacturer.

CAUTION: *Never cut into the ring travel area in excess of 1/32 inch when removing ridges.*

After the ridge has been removed, remove the cutter from the cylinder bore, then turn the crankshaft until the position is at the top of its stroke and carefully remove the cloth with the cuttings.

Turn the crankshaft until the connecting rod being removed is down. Remove the pal nuts and the hex head nuts from the connecting rod bolts. Pull the cap off the rod, then push the rod and piston assembly out the top of the cylinder with the handle end of a hammer.

CAUTION: *Avoid damage to the crankpin or the cylinder wall when removing the piston and rod.*

Remove the glaze from the cylinder wall (Chapter I). Repeat this procedure for each assembly.

NOTE: *Each rod and bearing cap is numbered from 1 to 6 from the front to the rear of the engine. The numbers on the rod and bearing cap must be on the same side when installed in the cylinder bore. If a connecting rod is ever transposed from one block or cylinder to another, new bearings should be fitted, and the rod should be numbered to correspond with the new cylinder number.*

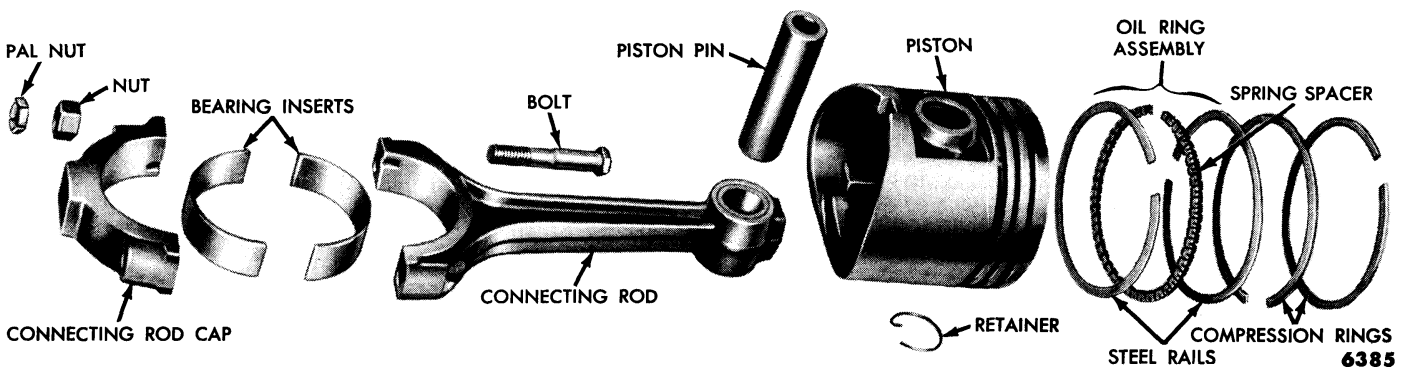

Fig. 24—Piston and Connecting Rod Disassembled

b. Piston and Connecting Rod Disassembly.

Mark the pistons and pins to assure assembly with the same rod and installation in the same cylinder from which they were removed. Remove the piston rings.

Remove the piston pin retainers, then drive the pin out of the piston and rod (fig. 25). Discard the retainers.

c. Piston and Connecting Rod Assembly.

Lubricate all parts with light engine oil.

NOTE: *Assemble the piston and connecting rod with the oil squirt hole in the rod positioned as shown in fig. 26.*

Position the connecting rod in the piston and push the pin into place.

Insert new piston pin retainers by spiraling them into the piston with the fingers. Do not use pliers.

Follow the instructions contained in the piston ring package and install the piston rings.

Be sure the bearings and journals are clean. If it is necessary to replace the connecting rod bearings, replace them at this time.

d. Piston and Connecting Rod Installation.

Oil the piston rings, pistons, and cylinder walls with light engine oil.

NOTE: *Be sure to install the pistons in the same cylinder from which they were removed, or to which they were fitted.*

Make sure the ring gaps are properly spaced around the circumference of the piston. Install a piston ring compressor on the piston and push the piston in with a hammer (fig. 27) until it is slightly below the top of

the cylinder. Be sure to guide the connecting rods to avoid damaging the crankshaft journals.

NOTE: *Install the piston with the indentation in the piston head toward the front of the engine.*

Check the bearing clearance using Plastigage (Chapter I). After the clearance has been checked, and found satisfactory, apply a light coat of engine oil to the journals and bearings. Turn the crankshaft throw to the bottom of its stroke, then push the piston all the way down until the rod bearing seats on the crankpin. Install the rod cap, then tighten the bolts to 45-50 foot-pounds torque. Install the pal nuts and tighten them to 3-4 foot-pounds torque.

After all the piston and rod assemblies have been installed, check the end play of the connecting rods (Chapter I).

Install the oil pan and cylinder head. Fill the crankcase with the proper grade and amount of lubricant. Fill the cooling system. Run the engine at fast idle. Make sure there is sufficient oil pressure and the engine does not overheat. Check for oil and coolant leaks.

e. Connecting Rod Bearing Replacement.

If the engine is removed and mounted on a stand, the bearings can be readily fitted. However, the bearings can be fitted without removing the engine as follows:

Remove the oil pan, then remove the oil pump.

Remove the connecting rod bearing caps to which new bearings are to be fitted. Push the piston up in the cylinder, then remove the upper and lower bearings.

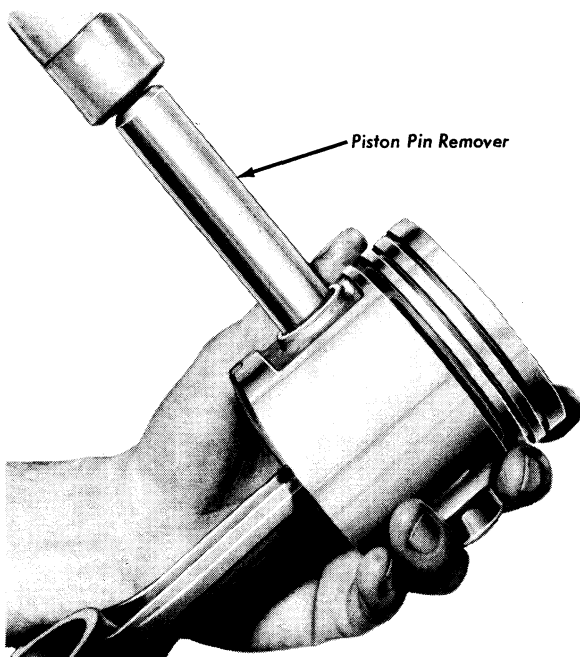
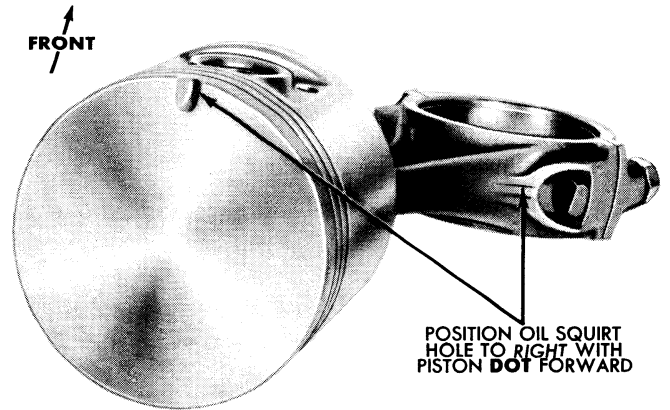

Fig. 25—Piston Pin Removal

6386



6387

Fig. 26—Correct Position of Oil Squirt Hole

Clean the crankshaft journal, the cap, and the upper half of the bearing bore.

NOTE: *When replacing standard bearings with new bearings, it is good practice to first try to obtain the proper clearance with two blue bearing halves.*

Install the new bearings in the rod and cap. Check the fit using Plastigage (Chapter I). After the bearing fit has been checked and found to be satisfactory, apply a light coat of engine oil to the journals and bearings, then install the rod cap. Tighten the bolts to 45-50 foot-pounds torque. Install the pal nuts, and tighten them to 3-4 foot-pounds torque. Repeat the procedure for the remaining bearings that need replacing.

After all the bearings have been replaced, install the oil pump and oil pan. Fill the crankcase, then operate the engine and check for oil pressure and oil leaks.

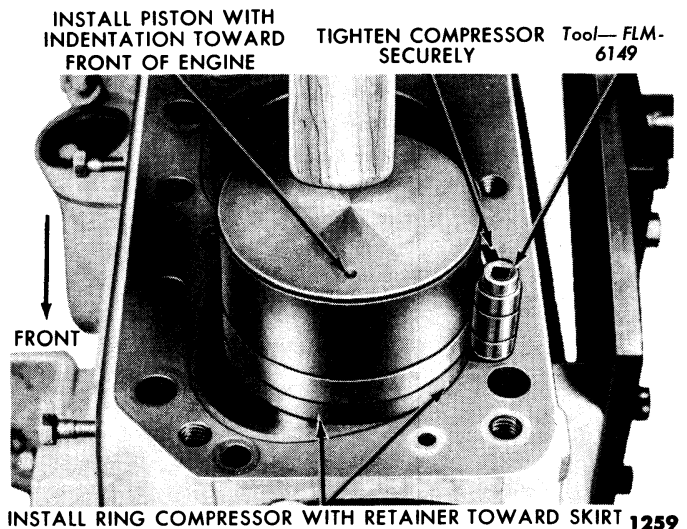

Fig. 27—Piston Installation

1259

9. OIL PAN, OIL FILTER, AND OIL PUMP

Procedures for the removal and installation of the above components are presented below.

a. Oil Pan.

(1) **REMOVAL.** Drain the crankcase. Remove the oil level indicator. Remove the engine left and right front splash aprons.

Remove the flywheel housing inspection cover. Remove the oil pan retaining screws and remove the pan and gasket.

(2) **INSTALLATION.** Make sure the gasket surfaces of the block and pan are clean and free from burrs. Coat the block surface and oil pan gasket surface with sealer and position the gasket on the oil pan. Hold the pan in place against the block and install a screw, finger tight, at each end of the pan. Install the remaining screws, then tighten the screws from the center outward in each direction to 12-15 foot-pounds torque.

Install the flywheel housing inspection cover. Install the engine right and left front splash aprons.

Install the oil level indicator. Fill the crankcase with the proper grade and quantity of engine oil. Run the engine and check for oil leaks.

b. Oil Filter.

The full flow-type oil filter (fig. 28) filters the entire output of the pump before the oil enters the engine lubrication system.

A built in by-pass provides oil to the system in case the filter element becomes clogged. The by-pass is located in the hollow center bolt and consists of a spring loaded valve. When the element is clean and oil will flow through it, the pressure difference between the inner and outer faces of the valve is not great enough to overcome the spring pressure behind the valve. Therefore, no oil flows through the by-pass. When the element is dirty and will not permit a sufficient flow of oil, the oil pressure acting on the inner face of the valve drops. If the pressure difference between the valve faces is great enough to overcome the spring pressure, the valve will open. Oil then by-passes the element, thereby maintaining an emergency supply of oil to the

engine lubrication system until the source of restriction to the normal oil flow is corrected.

(1) **REMOVAL.** Remove the filter from the bottom of the car. Place a drip pan under the filter. Remove the filter center bolt, then remove the filter assembly and gasket.

(2) **DISASSEMBLY.** Remove the filter element, neoprene gasket, spring, and seat, then remove the center bolt from the container and the fiber gasket from the bolt. Discard the filter element and all gaskets. Wash all parts in solvent. Make sure all the openings in the center bolt are clean.

(3) **ASSEMBLY.** Install a new fiber gasket on the center bolt, then place the bolt through the filter container. Install the spring and spring seat assembly on the bolt, making sure the seat tangs are engaged in the spring. Install a new neoprene gasket and a new filter element over the center bolt.

(4) **INSTALLATION.** Check to see if the two elongated holes in the oil filter anti-drain back diaphragm are in the up position as shown in fig. 29. Clean the cylinder block filter recess, then install a new gasket. Place the filter assembly in position, and thread the center bolt into the adapter finger-tight. Rotate the filter assembly slightly, in each direction, to make sure the gasket is seated evenly. Tighten the center bolt to 20-25 foot-pounds torque.

CAUTION: *Do not over tighten the center bolt.*

Refill the crankcase with oil if necessary, then operate the engine at fast idle, and check for leaks. If oil leaks are evident, perform the necessary repairs to correct the leakage.

c. Oil Pump.

A gear-type oil pump is mounted inside the crankcase in line with the distributor.

The pump is driven by means of an intermediate hex shaped drive shaft. The shaft is pinned into the end of the distributor drive shaft.

(1) **REMOVAL.** Remove the distributor, oil level indicator, and the oil pan. Remove the two nuts and lockwashers retaining the pump to the cylinder block. Remove the pump and gasket. Thoroughly clean the old gasket material from the mounting pad on the block and pump.

(2) **DISASSEMBLY.** Remove the screen assembly retaining screws, the screen assembly, and gasket. Remove the cover retaining screws, cover, and gasket. Push the pump drive shaft and drive gear assembly from the pump housing. Remove the driven gear. Remove the oil pressure relief valve chamber plug, spring, and plunger.

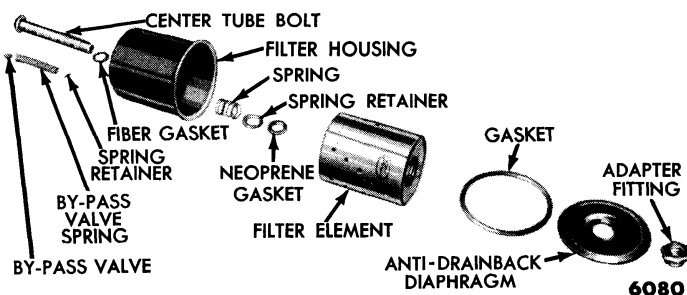

Fig. 28—Oil Filter Disassembled

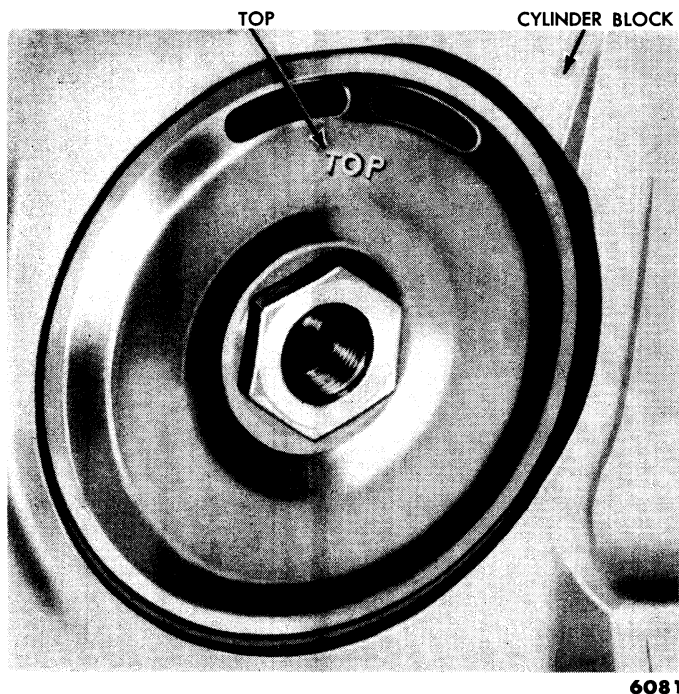

Fig. 29—Oil Filter Anti-Drain Back Diaphragm Position

Remove the snap wire retaining the pump screen, and remove the screen from the housing. The oil pump and screen are shown disassembled in fig. 30.

(3) **ASSEMBLY.** Apply a light coat of engine oil to all moving parts.

Install the pressure relief valve plunger, spring, and plug. Tighten the plug to 33-38 foot-pounds torque.

Slide the drive gear and shaft assembly into the housing. Install the driven gear. Check the end play of the gears using Plastigage or a dial indicator (Chapter I). Apply sealer to both sides of the pump cover gasket, then position the gasket on the pump. Install the pump cover, but do not tighten the retaining screws. Install

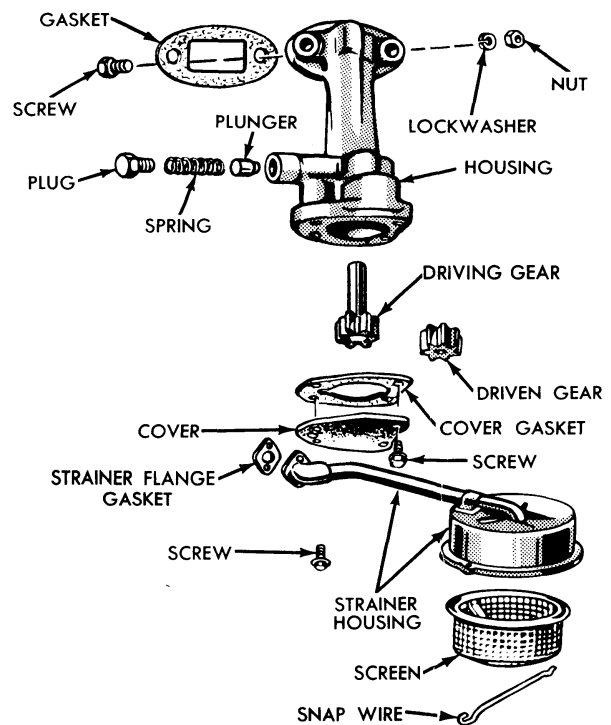

Fig. 30—Oil Pump Disassembled

the screen in the screen cover and secure it with the retainer. Install the inlet tube gasket, and the screen and inlet tube assembly on the pump cover. Tighten the retaining screws to 12-15 foot-pounds torque. Rotate the pump shaft by hand to make sure it turns freely.

(4) **INSTALLATION.** Place a new gasket on the retaining bolts, slide the pump mounting flange over the retaining bolts, and install the lock washers and nuts. Tighten the nuts to 30-35 foot-pounds torque. Install the distributor.

Install the oil pan. Fill the crankcase with the proper grade and quantity of oil.

Run the engine at fast idle and check for oil pressure and oil leaks.

10. EXHAUST SYSTEM

The exhaust system consists of a muffler, a muffler outlet pipe, and a muffler inlet pipe (fig. 31). These parts are provided as individual service parts.

NOTE: *When replacing any part of the exhaust system, loosen all the frame attaching bracket clamps to relieve twists in the system, then tighten the clamps.*

a. Muffler Replacement.

Extra heavy, double-wall constructed mufflers are available for service.

(1) **REMOVAL.** Loosen the outlet pipe to frame rear clamp, then remove the lower half of the clamp

at the rear of the muffler. Separate the outlet pipe and muffler, by sliding the outlet pipe to the rear. Loosen the muffler inlet pipe clamp and slide the clamp away from the muffler. Separate the muffler from the inlet pipe, then remove the muffler.

(2) **INSTALLATION.** Position the new muffler and clamp on the inlet pipe. Slide the muffler forward on the inlet pipe until the slots in the muffler extension are blocked. However, do not slide the muffler on the inlet pipe more than 1¾ inches. Align the muffler. Rotate the inlet pipe clamp downward approximately 45° so the clamp opening is not positioned directly opposite the slots in the muffler extension.

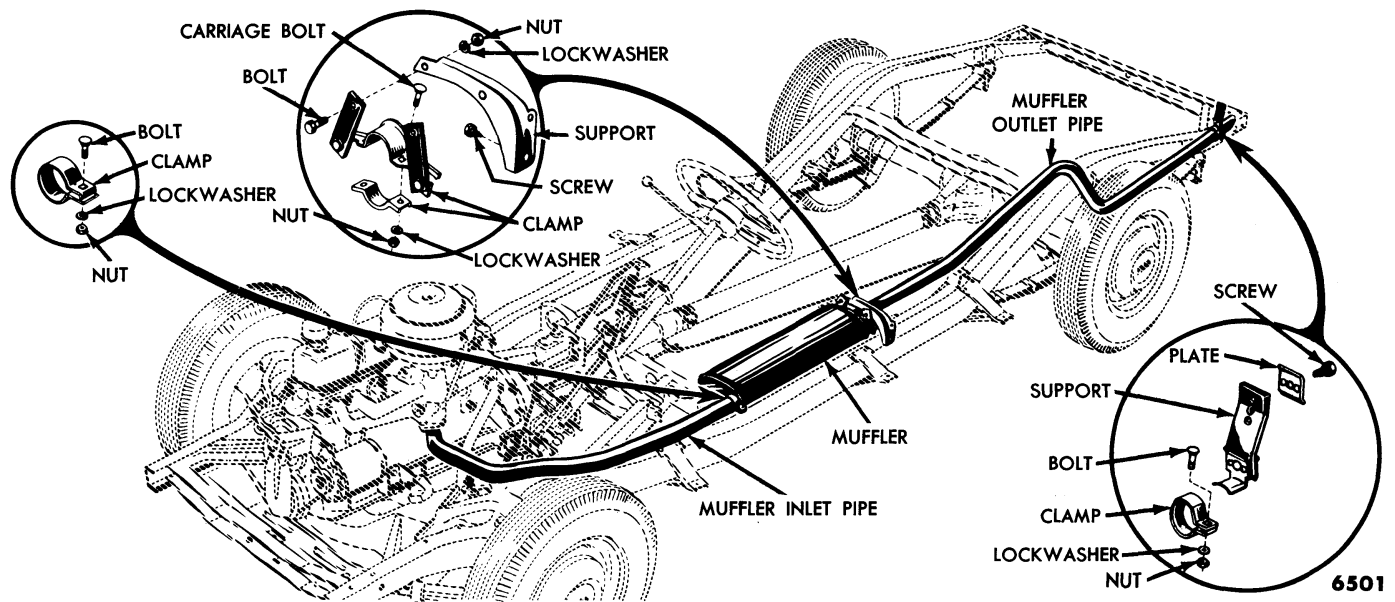

Fig. 31—Exhaust System

Slide the outlet pipe forward into the muffer extension until the slots in the muffer extension are blocked. However, do not slide the pipe into the muffer more than $1\frac{3}{4}$ inches. Connect, but do not tighten, the lower half of the clamp at the rear of the muffer. Check for possible interference between the outlet pipe “kick-up” and the floor pan. Reposition the outlet pipe if necessary. Tighten the outlet pipe clamps.

b. Outlet Pipe Replacement.

The outlet pipe is attached to the frame by flexible sound deadening materials which not only prevent the exhaust noises from being conducted through the chassis frame, but also relieve the exhaust system from twisting or bending stresses.

(1) **REMOVAL.** Remove the lower half of the clamp at the rear of the muffer, then remove the rear clamp from its support. Separate the muffer and outlet pipe.

(2) **INSTALLATION.** Slide the outlet pipe into the muffer extension until the slots in the muffer extension are blocked. However, do not slide the pipe into the muffer more than $1\frac{3}{4}$ inches. Slide the rear clamp on the outlet pipe and connect, but do not tighten it to its support. Connect, but do not tighten, the lower half of the clamp at the rear of the muffer. Check for possible interference between the outlet pipe “kick-up” and the

floor pan. Reposition the outlet pipe if necessary. Tighten the outlet pipe clamps.

c. Inlet Pipe Replacement.

The muffer inlet pipe is designed to give the exhaust gases leaving the exhaust manifolds a direct through passage to the muffer, thereby increasing the over-all efficiency of the exhaust system.

(1) **REMOVAL.** Loosen the outlet pipe clamps and the muffer inlet pipe clamp. Remove the two nuts fastening the inlet pipe to the exhaust manifold. Slide the muffer to the rear, then separate the muffer and inlet pipe. Remove the inlet pipe and gasket.

(2) **INSTALLATION.** Slide the clamp on the new inlet pipe, then slide the inlet pipe into the muffer extension until the slots in the extension are blocked. However, do not slide the pipe into the muffer more than $1\frac{3}{4}$ inches. Install a new gasket on the exhaust manifold outlet flange studs, then connect the inlet pipe to the exhaust manifold. Tighten the bolts to 23-28 foot-pounds torque. Position the muffer, then tighten the outlet pipe clamps. Rotate the inlet pipe clamp downward approximately 45 degrees so the clamp opening is not positioned directly opposite the slots in the muffer extension, then tighten the clamp.

Part ONE

POWER PLANT

Chapter III

8-Cylinder Engines

Section	Page
1 General Information	47
2 Engine Steady Rest	49
3 Manifolds	49
4 Cylinder Heads and Valves	51
5 Crankshaft Damper	54
6 Cylinder Front Cover and Crankshaft Oil Seal	55
7 Sprockets and Timing Chain, Camshaft and Bearings, and Tappets	56
8 Flywheel, Crankshaft, and Main Bearings	60
9 Connecting Rods and Bearings, Pistons, Pins, and Rings	62
10 Oil Pan, Oil Filter, and Oil Pump	64
11 Exhaust System	66

This chapter contains the removal, disassembly, assembly, and installation procedures for the component parts of the 8-cylinder engines.

The cleaning, inspection, and repair procedures for

the component parts and engine overhaul instructions are covered in Chapter I, "General Engine Overhaul, Inspection, and Repair." In addition, engine trouble shooting and tune-up are covered in Chapter I.

I. GENERAL INFORMATION

Removal and installation procedures of the component parts of all the 8-cylinder engines are the same unless otherwise noted. The engine models are listed in

Table 1 and a brief description of each engine is given below.

Table 1—Engine Models

Displacement (Cubic Inch)	Letter Designation	Compression Ratio	Exhaust	Transmission	Fuel Required	Carburetor Type
272	ECG	8.0:1	Single	STD. or O.D.	Regular	2-Venturi
272	ECG	8.4:1	Single	Fordomatic	Regular	2-Venturi
272*	ECG	8.0:1	Dual	STD. or O.D.	Regular	4-Venturi
272*	ECG	8.4:1	Dual	Fordomatic	Regular	4-Venturi
292	EDB	8.0:1	Dual	STD. or O.D.	Regular	4-Venturi
292	EDB	8.4:1	Dual	Fordomatic	Regular	4-Venturi
292*	EDB	9.0:1	Dual	Fordomatic	Premium	4-Venturi
292	ECJ	8.4:1	Dual	Standard	Premium	4-Venturi
312	ECJ	8.4:1	Dual	Overdrive	Premium	4-Venturi
312	ECJ	9.0:1	Dual	Fordomatic	Premium	4-Venturi
312	ECG	8.0:1	Dual	STD. or O.D.	Regular	4-Venturi
312	ECG	8.4:1	Dual	Fordomatic	Regular	4-Venturi

*Special

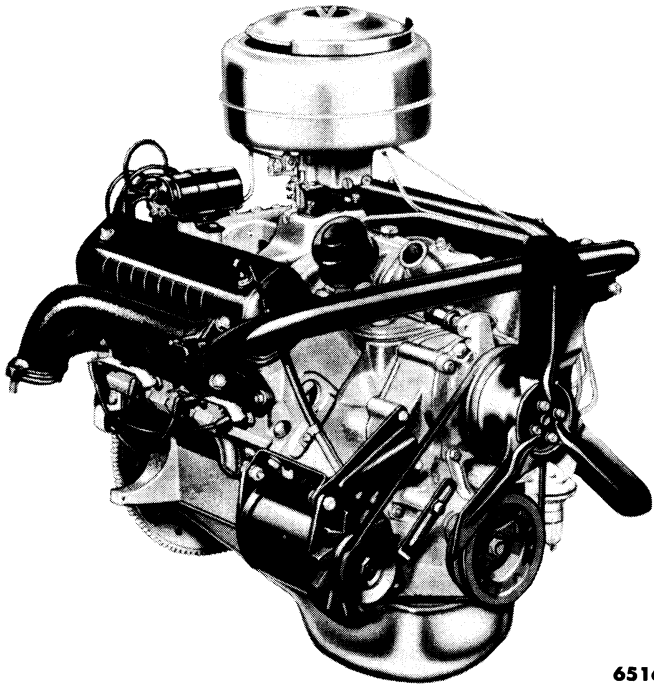

6516

Fig. 1—ECG 272 Cubic Inch Engine— $\frac{3}{4}$ Front View

a. 272 Cubic Inch Engine.

The 272 cubic inch engine (figs. 1 and 2) has a bore of 3.62 inches and a stroke of 3.30 inches.

b. 292 Cubic Inch Engine.

The 292 cubic inch engine has a bore of 3.75 inches and a stroke of 3.30 inches.

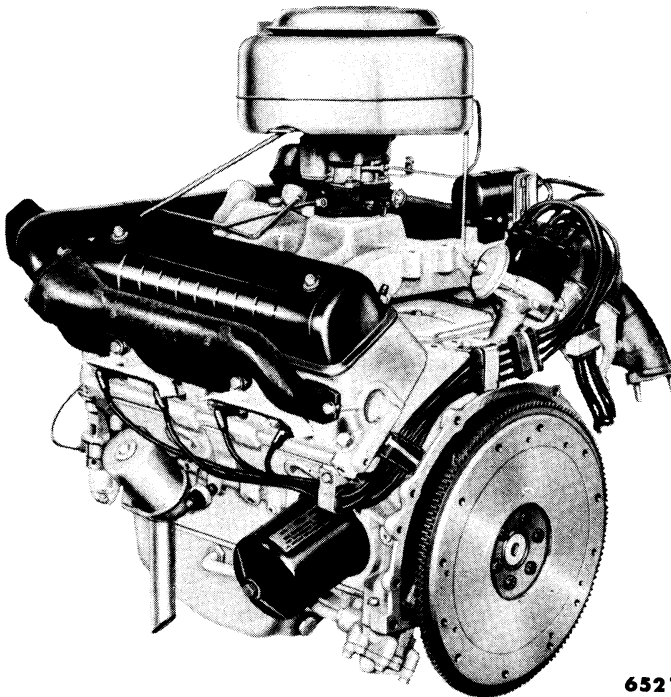

6521

Fig. 2—ECG 272 Cubic Inch Engine— $\frac{3}{4}$ Rear View

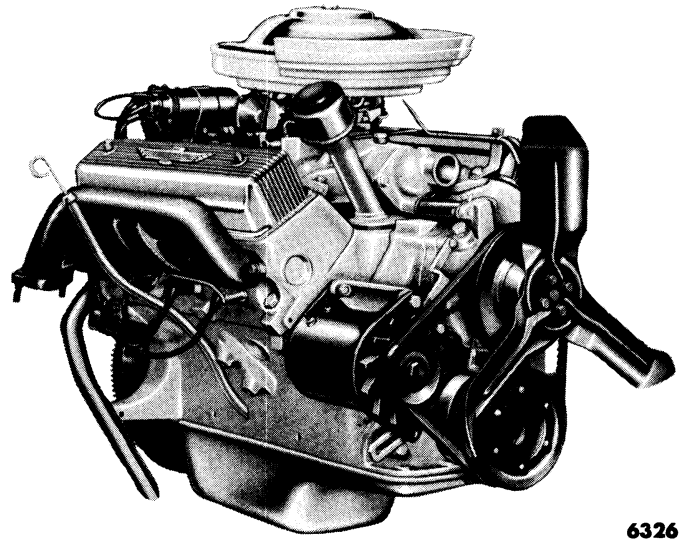

6326

Fig. 3—312 Cubic Inch Engine (Thunderbird)— $\frac{3}{4}$ Front View

c. 312 Cubic Inch Engine.

The 312 cubic inch engine (figs. 3 and 4) has a bore of 3.80 inches and a stroke of 3.44 inches.

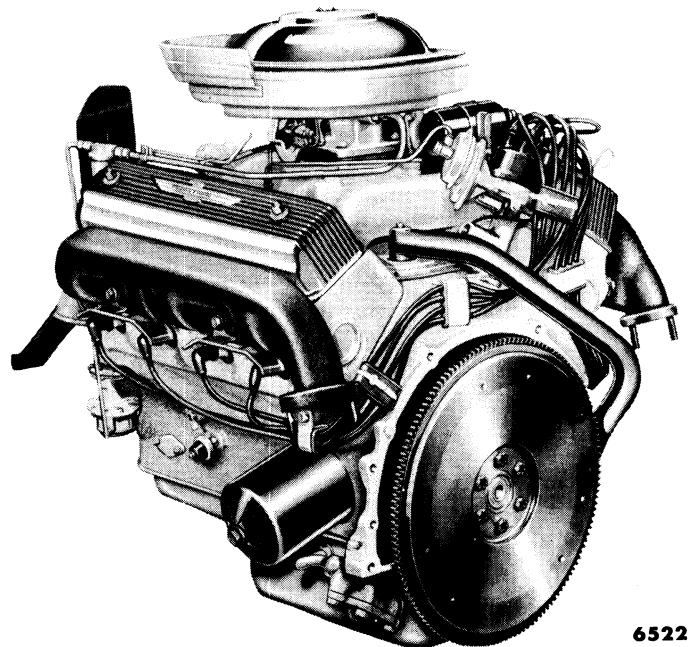

6522

Fig. 4—312 Cubic Inch Engine (Thunderbird)— $\frac{3}{4}$ Rear View

2. ENGINE STEADY REST

The engine steady rest does not support any engine weight and, as its name implies, it functions as a stabilizer only.

a. Conventional Car.

The steady rest (fig. 5) is mounted at the front of the engine.

(1) **REMOVAL.** Drain the cooling system, then remove the radiator. Remove the fan, all drive belts, and the crankshaft damper.

Remove the two clamp bolts at the front of the bracket assembly. Remove the spacer bolt and remove the spacer, insulators, and retainers. Remove the four bolts that fasten the bracket assembly to the cylinder front cover and remove the bracket assembly.

(2) **INSTALLATION.** Install the bracket assembly on the cylinder front cover, then tighten the bolts to 23-28 foot-pounds torque. Position the top insulator and spacer on the frame cross member. Position the lower in-

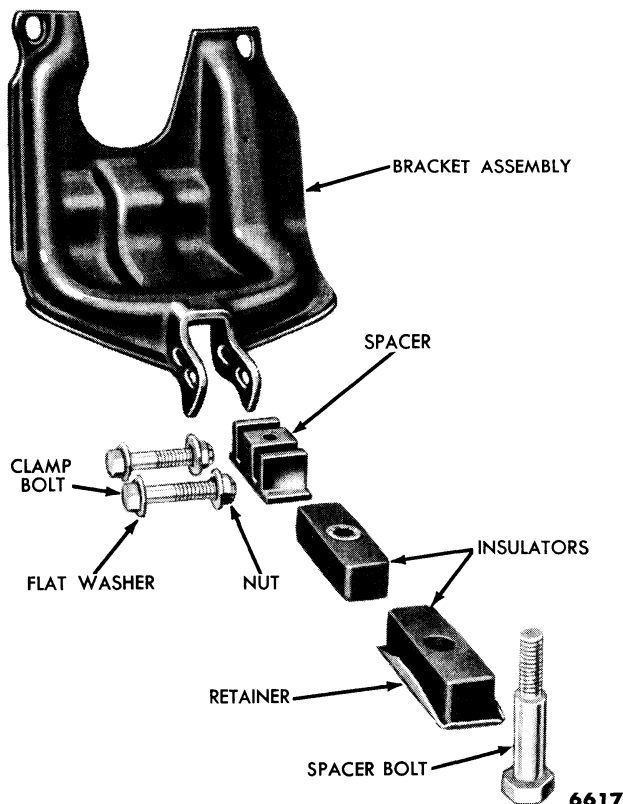

Fig. 5—Steady Rest Disassembled—Conventional Car

ulator and retainer, then install the spacer bolt.

NOTE: If necessary, center the spacer bolt in the frame bracket by shifting the engine front supports in their frame brackets.

Tighten the spacer bolt to 20-25 foot-pounds torque. Make sure engine weight is not being transferred to the insulators, then install and tighten the clamp bolts to 25-30 foot-pounds torque. Install the crankshaft damper.

Install and adjust all drive belts. Install the radiator, then fill the cooling system.

b. Thunderbird.

A steady rest (fig. 6) is mounted on each side of the engine. The procedures are identical for each steady rest.

(1) **REMOVAL.** Remove the upper and lower bracket retaining bolts, then remove the steady rest assembly from the car.

(2) **DISASSEMBLY.** Remove the nut, washer, bushing, and washer from the lower end of the steady rest rod, then remove the lower bracket. Remove the remaining lower bushing and washer.

Remove the nut, washer, insulator, and bracket from the top of the rod. Remove the remaining insulator, washer, and nut from the top of the rod.

(3) **ASSEMBLY.** Assemble the bottom nut, washer, insulator, and bracket on the upper end of the rod. Install the top insulator, washer, and nut on the upper end of the rod. Assemble the top washer, bushing, and the bracket on the lower end of the rod. Install the bottom washer, bushing, washer, and nut on the lower end of the rod.

(4) **INSTALLATION.** Install the assembly in the car. Tighten the bracket bolts to 30-35 foot-pounds torque. Adjust the steady rest as outlined in the Thunderbird Engine Installation procedure (Chapter I).

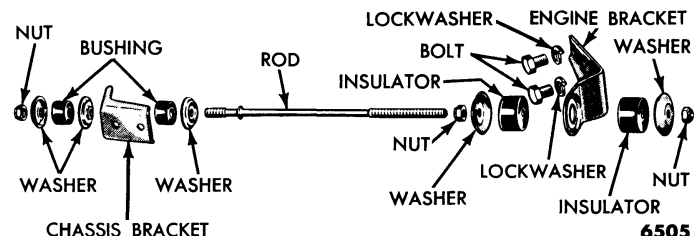

Fig. 6—Steady Rest Disassembled—Thunderbird

3. MANIFOLDS

The following procedures cover the removal and installation of the intake and exhaust manifolds.

a. Intake Manifold.

The intake manifold is bolted to the cylinder heads

and straddles the center portion of the cylinder block. The manifold and attached accessories can be removed as an assembly.

All 8-cylinder intake manifolds contain a passage

through the center section and under the carburetor, through which hot exhaust gases are directed to assist in vaporizing the incoming fuel charge, thus assuring improved fuel distribution. In addition, stalling and carburetor icing are minimized during cold engine operation. The exhaust gases are diverted into the intake manifold by a thermostatically controlled exhaust valve.

On cars equipped with a single exhaust system, the valve is located between the crossover pipe and the inlet of the right exhaust manifold. When the valve is closed or in the "heat on" position part of the exhaust gases are diverted from the left exhaust manifold, through the heat riser passage, to the right exhaust manifold. When the valve opens (heat off) more of the exhaust gases from the left manifold are permitted to flow directly out the exhaust system in the normal manner.

On cars equipped with a dual exhaust system, the valve is installed at the outlet of the right exhaust manifold. Therefore, the exhaust gases flow from the right to the left through the heat riser passage.

(1) **REMOVAL.** Drain the radiator. Remove the air cleaner. Tape the air horn of the carburetor closed.

Disconnect the windshield wiper hose, the vacuum line at the intake manifold, and the fuel line at the fuel pump and at the carburetor. Remove the vacuum lines from the fuel pump, and remove the three lines as an assembly.

Disconnect the distributor vacuum line at the distributor. Disconnect the throttle linkage. Remove the throttle linkage bracket from the intake manifold.

NOTE: On the Thunderbird, disconnect the throttle pull back spring.

Disconnect the primary and secondary wires at the coil. Disconnect the heater inlet hose and the heater vacuum control line at the water control valve. Disconnect the radiator upper hose and the water pump by-

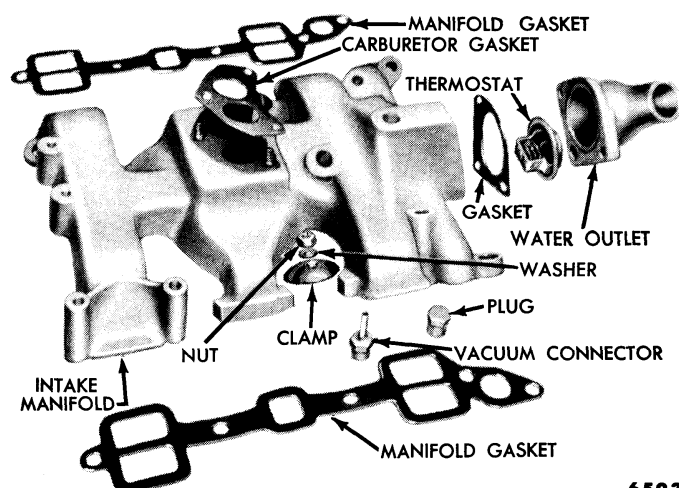

Fig. 7—Intake Manifold—Typical

6523

pass hose.

Remove the manifold retaining bolts, nuts, and four clamps, then remove the manifold (and gaskets), carburetor, and coil as an assembly.

The two-barrel carburetor manifold is shown in fig. 7.

(2) **INSTALLATION.** Using new gaskets, install the manifold. Align the holes in the manifold gaskets and manifold with the cylinder head tapped holes. Position the manifold clamps, install the manifold retaining bolts and nuts, and tighten them to 23-28 foot-pounds torque, working from the center to the ends.

Connect the radiator upper hose and the water pump by-pass hose. Connect the heater vacuum control line and the heater inlet hose. Connect the primary and secondary coil wires.

NOTE: On the Thunderbird, connect the throttle pull back spring.

Install the throttle linkage bracket on the intake manifold. Connect the throttle linkage. Connect the distributor vacuum line.

Install the windshield wiper line, intake vacuum line, and the fuel pump to carburetor line as an assembly. Connect the three lines at the fuel pump. Connect the windshield wiper hose, then connect the vacuum line to the intake manifold and the fuel line at the carburetor.

Remove the tape from the air horn of the carburetor. Install the air cleaner. Fill the radiator.

b. Exhaust Manifolds.

The exhaust manifolds, of the dual exhaust equipped cars, are of special design to provide outlets to the separate exhaust systems.

(1) **REMOVAL — SINGLE EXHAUST SYSTEM.** Disconnect the crossover pipe from both manifolds. Remove the crossover pipe and the exhaust gas control valve. Disconnect the muffler inlet pipe from the right manifold. Remove the bolts, flat washers, spark plug heat shields, and manifolds. Remove the gasket and heat shield assemblies. The exhaust manifolds and the crossover pipe assembly are shown in fig. 8.

(2) **INSTALLATION — SINGLE EXHAUST SYSTEM.** Coat the mating surface of the manifold with a light film of graphite grease. Start the manifold rear bolt into the cylinder head. Hook the manifold on the rear bolt, then install the spark plug heat shields and remaining washers and retaining bolts. Tighten the bolts, working from the center to the ends, to 23-28 foot-pounds torque. Install the exhaust gas control valve at the front of the right manifold with a new gasket on both sides. Install one crossover pipe gasket on the left manifold. Place the crossover pipe on the manifold studs, and install the retaining nuts. Tighten the nuts to 23-28 foot-pounds torque. Install a new gasket and connect the muffler inlet pipe.

(3) **CROSSOVER PIPE REPLACEMENT.** Remove the nuts and lockwashers retaining each end of the pipe to the manifolds. Remove the crossover pipe, exhaust gas control valve, and gaskets.

Position the exhaust gas control valve on the right manifold with a new gasket on each side. Position a new gasket on the left manifold, then install the crossover pipe. Tighten the nuts to 23-28 foot-pounds torque.

(4) **REMOVAL DUAL EXHAUST SYSTEM.** The removal procedure for both exhaust manifolds is the same. Disconnect the muffler inlet pipe from the manifold. Remove the bolts, flat washers, spark plug heat shields, and the manifold.

Remove the exhaust gas control valve with the right exhaust manifold.

(5) **INSTALLATION—DUAL EXHAUST SYSTEMS.** Coat the mating surfaces of the manifolds with a light film of graphite grease. Start the manifold rear bolt into the cylinder head. Hook the manifold on the rear bolt, then install the spark plug heat shields, and the remaining bolts. Tighten the bolts, working from the center to the ends, to 23-28 foot-pounds torque. Using a new gasket on both sides, install the exhaust gas control valve on the right manifold. Install the muffler inlet pipe. Tighten the retaining nuts to 23-28 foot-pounds torque.

c. Exhaust Gas Control Valve Replacement.

(1) **SINGLE EXHAUST SYSTEM.** Remove the

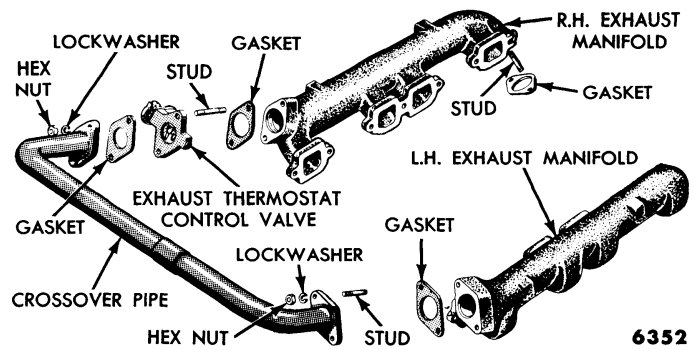

Fig. 8—Manifolds and Crossover Pipe—Single Exhaust System

manifold crossover pipe, then remove the control valve from the right-hand manifold. Clean the manifold and crossover pipe flanges. Place a new gasket on both sides of the control valve and position the valve on the right manifold. Install the crossover pipe. Tighten the nuts to 23-28 foot-pounds torque.

(2) **DUAL EXHAUST SYSTEM.** Remove the right exhaust manifold. Remove the control valve from the muffler inlet pipe. Clean the inlet pipe and manifold flanges.

Place a new gasket on both sides of the control valve and position the valve on the muffler inlet pipe. Install the exhaust manifold. Tighten all mounting bolts to 23-28 foot-pounds torque.

4. CYLINDER HEADS AND VALVES

The cylinder head contains the valves and the rocker arm mechanism.

The left and right cylinder heads on each particular engine are interchangeable, provided a water outlet plug or temperature sending unit insert is removed from one end of the head and a new plug or insert is installed in the other end. Cylinder heads serviced in the field will not have the water outlet plug or insert installed, so they can be used for either right or left installations.

The plug is installed in the rear water outlet opening of the right cylinder head by using the tool shown in fig. 9. The temperature sending unit insert is installed in the rear water outlet opening of the left cylinder head with the same tool. Be sure to apply a light coat of water resistant sealer to the sealing surface of the plug or insert before installation.

NOTE: *Installation of the correct cylinder head is extremely important. If the incorrect head is installed, rough engine operation will occur. To insure installation of the correct head, use the identifications given in Table 2.*

The intake and exhaust valves are the rotating type and incorporate umbrella-type valve stem seals (fig. 10).

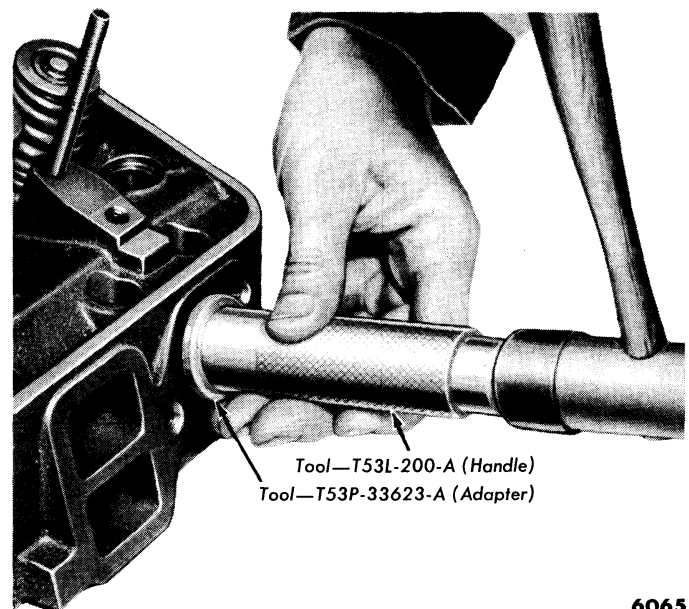

Fig. 9—Cylinder Head Water Outlet Plug Installation

Table 2—Cylinder Head Identification

Engine (Cubic Inch)	Compression Ratio	Identification
272	8.0:1	ECZ-C
272	8.4:1	ECG-H
292	8.0:1	ECZ-B
292	8.4:1	ECZ-C
292	9.0:1	ECG-H
312	8.0:1	ECZ-A
312	8.4:1	ECZ-B
312	9.0:1	ECZ-C

a. Cylinder Head Removal.

Drain the cooling system. Clean the outside of the rocker arm cover and remove the cover. Remove the exhaust manifold, the spark plugs, and the intake manifold. Remove the ignition harness bracket from the right cylinder head.

When removing the right head from the Thunderbird, remove the distributor cap. When removing the right head from all other cars, disconnect the battery ground cable, and the oil level indicator tube bracket from the cylinder head. Remove the generator bracket to cylinder head bolt, remove the generator front mounting bolt, and move the generator out of the way.

Release the spring tension on the rocker arms by loosening the adjusting screws, then remove the rocker arm assembly and oil baffle plates. Remove and identify the push rods so they can be replaced in their original positions (fig. 11). Disconnect the wire from the temperature sending unit.

Remove the cylinder head bolts. Install the cylinder head holding fixtures (fig. 12).

NOTE: *On the Thunderbird, install the rear fixture on the right head one hole forward because of interference with the distributor.*

Lift the cylinder head off the block. Do not pry between the head and block. Remove the head gasket.

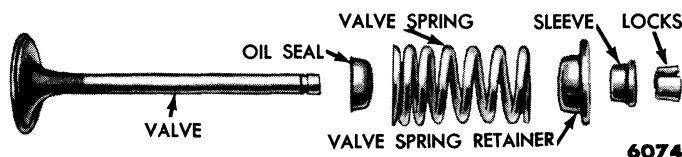

Fig. 10—Rotating-Type Valve Assembly

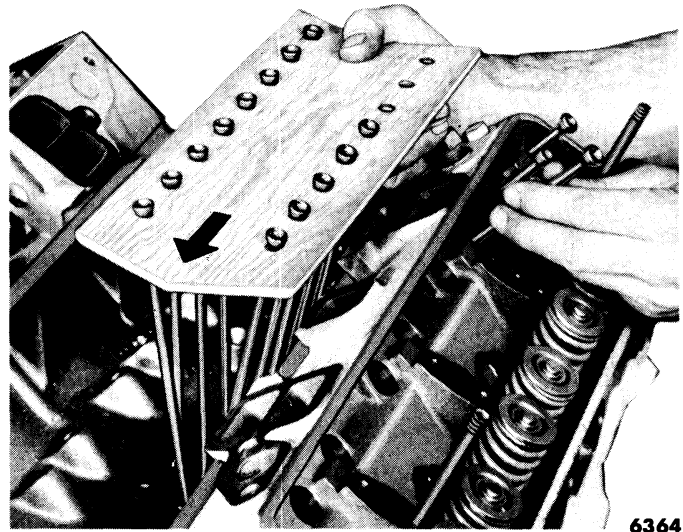

Fig. 11—Valve Push Rod Removal

b. Rocker Shaft Disassembly.

Remove the cotter pins from each end of the rocker arm shaft, then remove the flat washers and spring washers. Slide the rocker arms, springs, and brackets off the shaft. Be sure to identify the parts. Remove the plugs from each end of the shaft.

NOTE: *The plugs are an interference fit. To remove the plugs, drill or pierce one plug, then insert a steel rod through the plug and knock out the plug on the opposite end. Working from the open end, knock out the remaining plug.*

c. Cylinder Head Disassembly.

Clean the carbon out of the cylinder head combustion chambers before removing the valves. Compress the valve springs (fig. 13), then remove the spring retainer

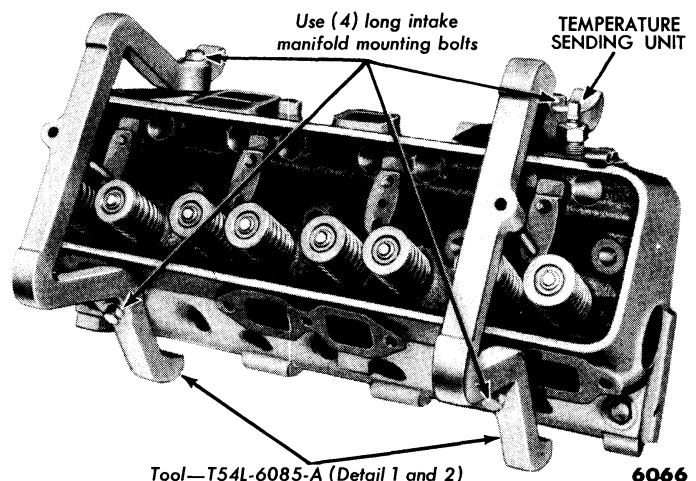

Fig. 12—Cylinder Head Holding Fixture

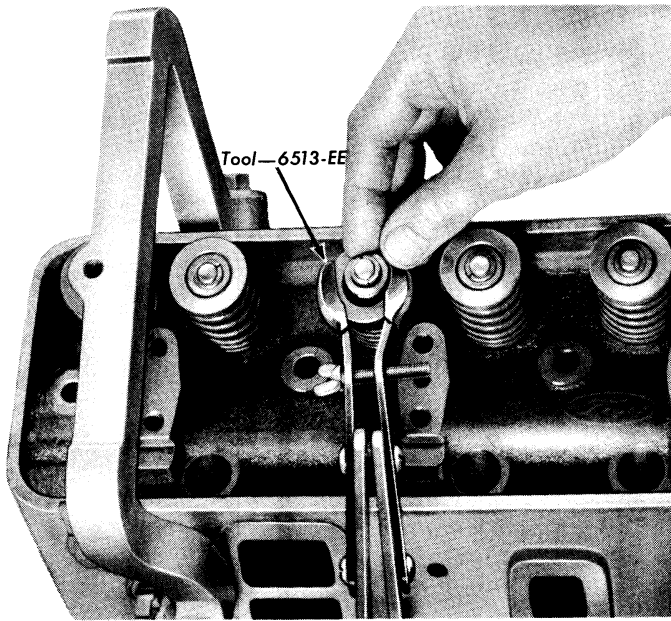

Fig. 13—Removing or Installing Spring Retainer Locks

locks, and release the spring.

Remove the sleeve, spring retainer, spring, stem seal, and valve. Discard the valve stem seals. Identify all valve parts.

d. Rocker Shaft Assembly.

Oil all moving parts with engine oil. Using a blunt tool or large diameter pin punch, install a plug, cup side out, in each end of the rocker shaft. Install a flat washer, spring washer, another flat washer, and a cotter pin on one end of the shaft. Install the rocker arms, support brackets, and springs in the order shown in fig. 14.

Complete the assembly by installing the remaining two flat washers with the spring washer between them and install the cotter key.

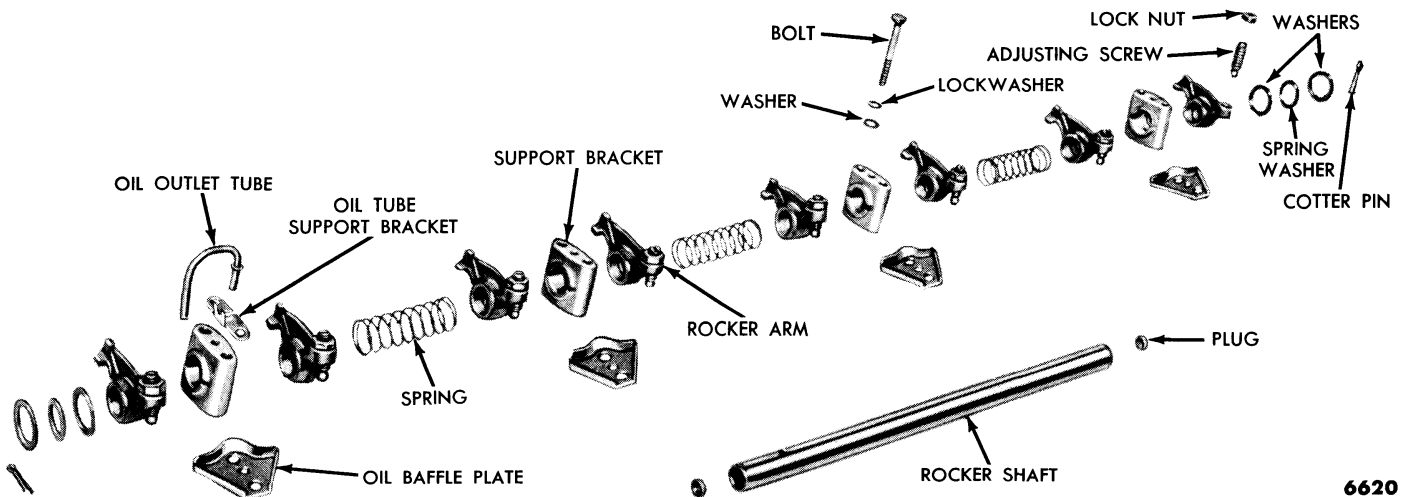

Fig. 14—Rocker Arm Mechanism Disassembled

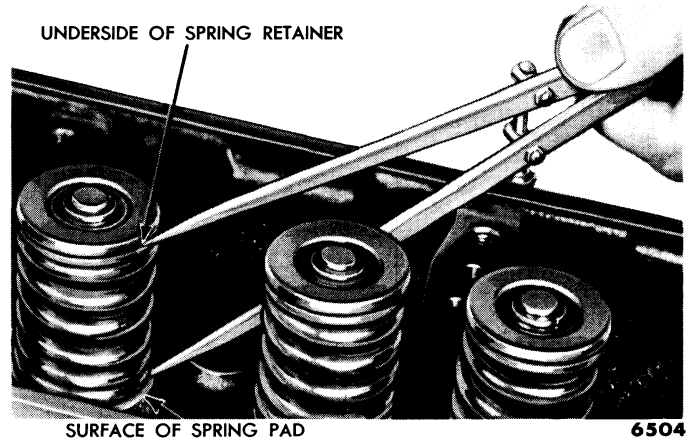

Fig. 15—Checking Valve Spring Assembled Height—Typical

e. Cylinder Head Assembly.

Install each valve in the port from which it was removed or to which it was fitted. Install a stem seal on the valve. Install the valve springs with the tightly wound coil end of the spring against the head surface, then install the spring retainer and sleeve. Compress the spring and install the retainer locks. (fig. 13).

Measure the valve spring assembled height from the machined surface of the cylinder head spring pad to the spring retainer contact surface as shown in fig. 15. If the assembled height is $1\frac{3}{16}$ inches or greater, install the necessary 0.030 inch thick spacer and/or spacers between the cylinder head valve spring pad and the valve spring to bring the assembled height to the recommended dimension of $1\frac{25}{32}$ – $1\frac{13}{16}$ inches.

CAUTION: Do not install spacers unless necessary. Use of spacers in excess of recommendations will result in overstressing the valve springs which leads to excessive load loss and spring breakage.

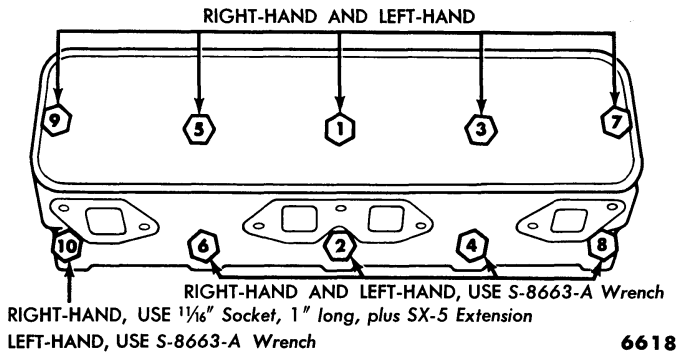

Fig. 16—Cylinder Head Bolt Tightening Sequence—Typical

f. Cylinder Head Installation.

Apply a coating of head gasket sealer to both sides of a new head gasket. Use the brush furnished to spread the sealer evenly over the entire gasket surface. Guided by the word "front" embossed on the gasket, install the head gasket over the cylinder head dowels.

Place the cylinder head on the engine. Remove the holding fixtures. Coat the head bolt threads with water resistant sealer. Install the bolts. The cylinder head bolt tightening procedure is performed in three progressive steps. First, tighten the bolts to 55 foot-pounds torque (cold) in the sequence shown in fig. 16, then tighten them to 65 foot-pounds torque (cold) in the same sequence. Install the push rods in their proper sequence. Position the lower end of the rods in the tappet sockets. Position the oil baffle plates on the head, then place the rocker assembly on the plates. Install, but do not tighten, the bracket retaining screws and nuts. Be sure to install the oil drain tube on the same end bracket from which it was removed. The bracket end of the tube must enter the locating hole in the rocker shaft to properly position the shaft. Position the oil drain tube on the right rocker assembly so the oil will drain in the front (number 1 exhaust) push rod opening (fig. 17). Position the oil drain tube on the left rocker arm assembly so the oil will drain in the end (number 8 exhaust) push rod opening.

CAUTION: *Be sure the rocker shaft support brackets are not installed upside down as there is a difference in height when installed in this position.*

Tighten the bracket retaining screws and nuts to 12-15 foot-pounds torque. Perform a preliminary (cold) valve lash adjustment.

5. CRANKSHAFT DAMPER

A single sheave crankshaft damper and pulley assembly is standard on passenger cars, while on Thunderbirds a double sheave assembly is standard. Both type assem-

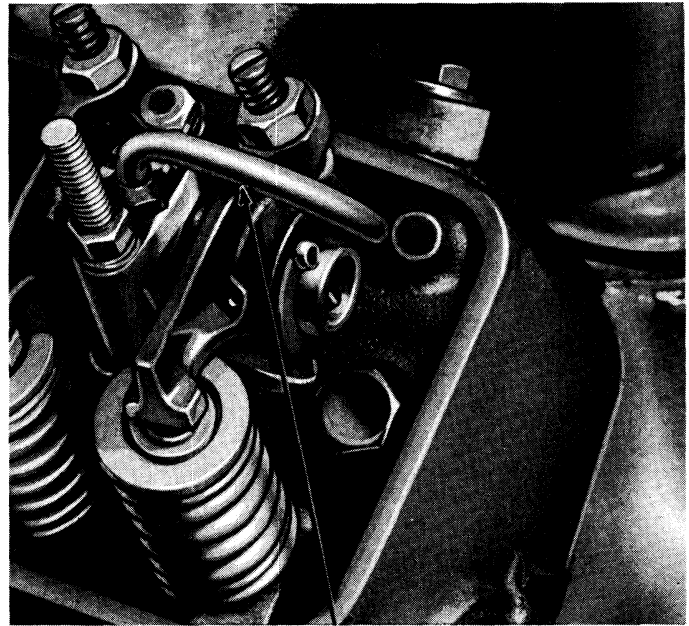

ROCKER ARM SHAFT OIL OUTLET TUBE

6619

Fig. 17—Rocker Shaft Oil Drain Tube Position—Typical

Connect the temperature sending unit wire.

After installing the right head on all cars, except the Thunderbird, position the generator, and install the generator front mounting bolt, then fasten the generator bracket to the cylinder head. Connect the battery ground cable and the oil level indicator tube bracket.

After installing the right head on the Thunderbird, install the distributor cap.

Attach the ignition harness bracket. Install the intake manifold. Install the spark plugs, then install the exhaust manifolds.

Fill the cooling system and run the engine for a minimum of 30 minutes at approximately 1200 r.p.m. With the engine warmed up, tighten the head bolts, in proper sequence, to 75 foot-pounds torque (hot), then check the valve lash with engine idling and adjust it if necessary.

NOTE: *After the cylinder head bolts have been tightened to specifications the bolts should not be disturbed.*

Coat one side of the rocker arm cover gaskets with oil resistant sealer, and lay the cemented side of the gasket in place in the covers. Install the rocker arm covers, making sure that the gasket seats evenly all around the head. Install the rubber seals on the studs making sure they are centered in the cover openings. Tighten the retaining nuts to 2.0-2.5 foot-pounds torque.

blies are pressed on, and keyed to, the front of the crankshaft and are retained by a large cap screw and washer.

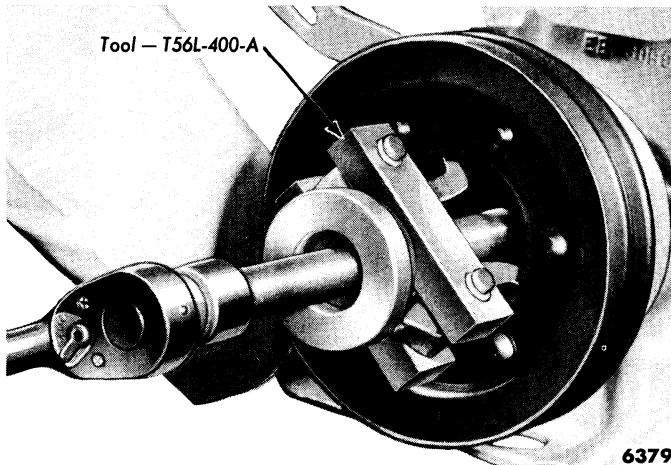

Fig. 18—Crankshaft Damper Removal—Thunderbird

On passenger cars equipped with power steering, an additional single sheave pulley is bolted to the crankshaft damper to drive the power steering pump.

On passenger cars equipped with power steering and air conditioning a special three sheave damper is used. This damper is retained on the crankshaft in the same manner as the single sheave damper.

a. Removal.

Remove the radiator. Remove the fan and drive belts.

On passenger cars equipped with a separate power steering pulley, remove the two cap screws and lock washers securing the pulley to the crankshaft damper, then remove the pulley. Remove the large cap screw and washer from the end of the crankshaft.

Install the puller on the crankshaft damper (fig. 18 or 19) and remove the damper.

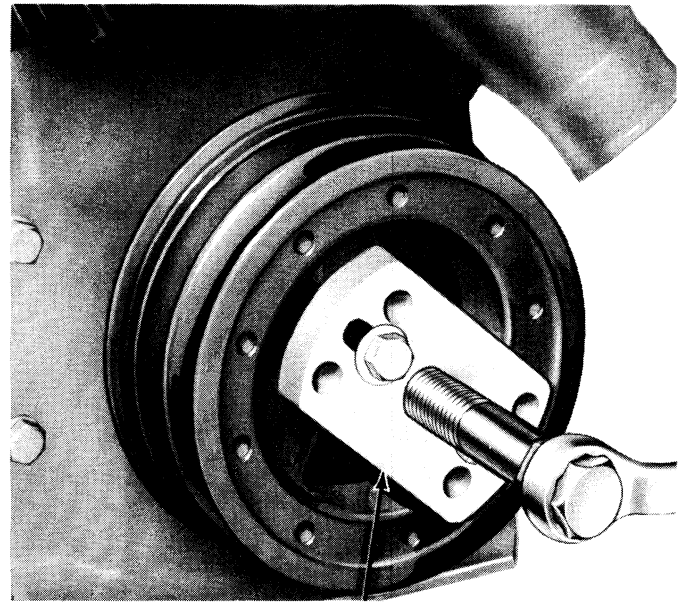

Fig. 19—Crankshaft Damper Removal—272, 292, 312 (Police Interceptor) Cubic Inch Engines

b. Installation.

Lubricate the crankshaft with a white lead and oil mixture and lubricate the oil seal rubbing surface with grease. Line up the damper keyway with the key on the crankshaft. Drive it on the crankshaft using Tool—T52L-6406-AEE. Install the damper cap screw and washer, and tighten it to specifications. Install the air conditioning and/or power steering belt if applicable.

On passenger cars equipped with a separate power steering pulley, attach the pulley to the crankshaft damper. Tighten the screws to 23-28 foot-pounds torque. Install and adjust the drive belt(s). Install the radiator.

6. CYLINDER FRONT COVER AND CRANKSHAFT OIL SEAL

The cylinder front cover is fastened to the cylinder block by ten hex-head cap screws and to the oil pan by four cap screws. The cover retaining bolts also support the engine steady rest (front support on Thunderbirds). The water pump (and spacer on Thunderbirds) and fuel pump are mounted on the cover.

NOTE: *It is good practice to replace the crankshaft oil seal each time the cylinder front cover is removed.*

a. Cylinder Front Cover Removal.

Remove the radiator, the fan blades and hub, crankshaft damper, fuel pump, and the oil pan.

On cars equipped with power steering, disconnect the power steering pump bracket from the water pump and move the power steering pump out of the way.

On passenger cars, remove the engine steady rest.

On Thunderbirds, support the engine, then remove the engine front support.

On cars equipped with air conditioning, remove the condenser brackets from the front cover and move them out of the way.

Remove the generator mounting bracket bolts from the cylinder front cover, and move the bracket out of the way. Loosen the generator adjusting bracket and move it out of the way. Disconnect the water by-pass tube.

Remove the remaining bolts, then remove the water pump (and spacer on Thunderbirds) and front cover as an assembly.

b. Oil Seal Replacement.

Drive out the crankshaft oil seal with a pin punch, then clean out the recess in the cover. Coat a new seal

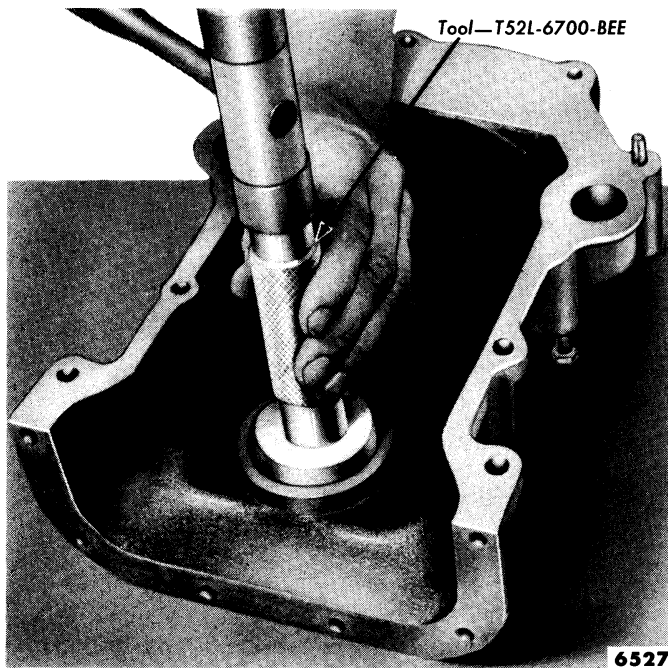
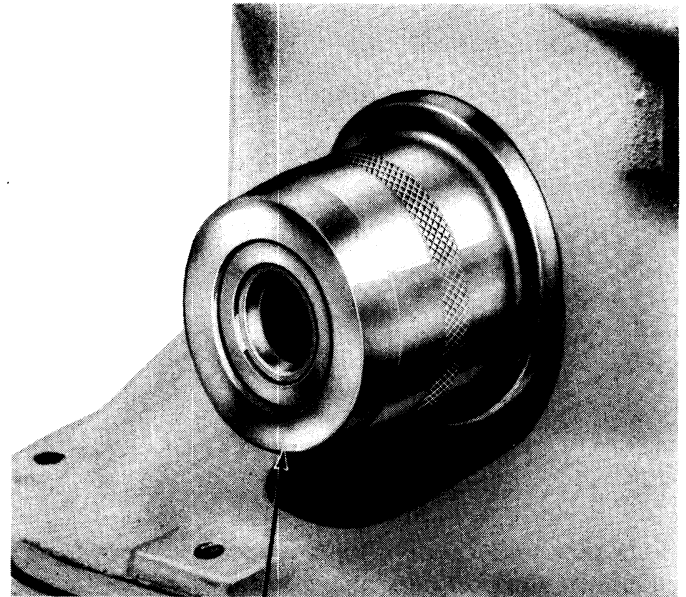

Fig. 20—Crankshaft Oil Seal Installation—Typical

with grease, then install the seal (fig. 20). Drive the seal in until it is fully seated in the recess. Check the seal after installation to be sure the spring is properly positioned in the seal.

c. Cylinder Front Cover Installation.

Clean the cylinder front cover and the gasket surface of the cylinder block. Coat the gasket surface of the block and cover and the cover bolt threads with sealer. Position a new gasket on the block. Insert the large diameter end of the oil seal pilot in the bore of the cover. Position the cover and pilot assembly over the end of the crankshaft and against the block (fig. 21). While pushing in on the pilot, install and tighten the



Tool—T52L-6059-AAE

6506

Fig. 21—Cylinder Front Cover Alignment—Typical

cover bolts. Tighten the $\frac{3}{8}$ inch bolts to 23-28 foot-pounds torque and the $\frac{5}{16}$ inch bolts to 12-15 foot-pounds torque. Install the oil pan.

On passenger cars, install the engine steady rest.

On Thunderbirds, install the engine front support, then remove the jack supporting the engine.

On cars equipped with power steering, connect the power steering pump bracket to the water pump.

On cars equipped with air conditioning, connect the condenser brackets to the cylinder front cover.

Install the water by-pass tube and the crankshaft damper. Using a new gasket, install the fuel pump. Install the fan blades and hub. Install and adjust the drive belts.

Install the radiator, then fill the cooling system. Operate the engine and check for coolant and oil leaks.

7. SPROCKETS AND TIMING CHAIN, CAMSHAFT AND BEARINGS, AND TAPPETS

The camshaft is supported by five steel-backed babbitt insert-type bearings pressed into the block. It is driven by a sprocket and timing chain in mesh with a sprocket on the crankshaft. Camshaft thrust is controlled by a spacer and a thrust plate located between the camshaft sprocket and the shoulder on the camshaft. The thrust plate is bolted to the front of the block.

a. Sprockets and Timing Chain and Fuel Pump Eccentric.

The camshaft sprocket is a slip fit on, and is keyed

to, the end of the camshaft. The camshaft sprocket, counterweight, fuel pump eccentric, spacer washer, and lockwasher are retained on the camshaft by a cap screw.

(1) **REMOVAL.** Remove the radiator, fan blades, and hub, the cylinder front cover, and oil pan. Remove the camshaft sprocket cap screw and lockwasher. Remove the fuel pump eccentric and counterweight from the camshaft.

Crank the engine until the timing marks on the sprockets and chain are positioned as shown in fig. 22. Slide both sprockets and the timing chain forward, and

remove the sprockets and the timing chain as an assembly (fig. 23).

(2) **INSTALLATION.** Place the keys in position on the crankshaft and camshaft. Position the sprockets and timing chain on the camshaft and crankshaft (fig. 23). Be sure the timing marks on the sprockets and chain are positioned as shown in fig. 22. There are 12 timing chain link pins between the timing marks on the sprockets.

Install the camshaft counterweight and fuel pump eccentric (fig. 24). Install the camshaft sprocket cap screw, lockwasher, and spacer. Tighten the sprocket cap screw to specifications.

Install the cylinder front cover, fuel pump, crankshaft damper, and the oil pan. Install and adjust the drive belts.

Install the hub, fan blades, the radiator, and radiator grille support bracket.

b. Camshaft.

The camshaft and related parts are shown in fig. 25.

(1) **REMOVAL.** Remove the radiator, radiator grille support bracket, cylinder front cover, and oil pan.

Remove the intake manifold, carburetor, and coil as an assembly. Remove the rocker arm covers, then remove both rocker arm assemblies. Remove the valve push rods in sequence. Remove the push rod chamber cover.

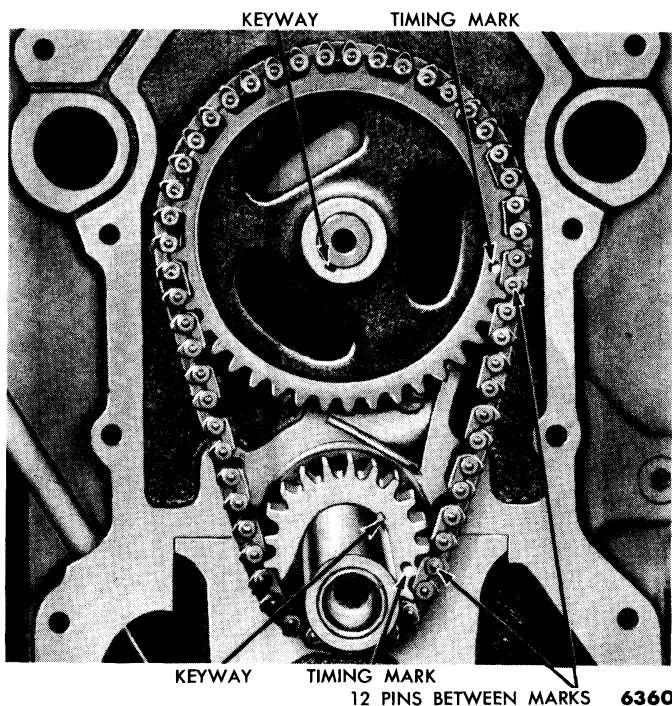

Fig. 22—Aligning Timing Marks

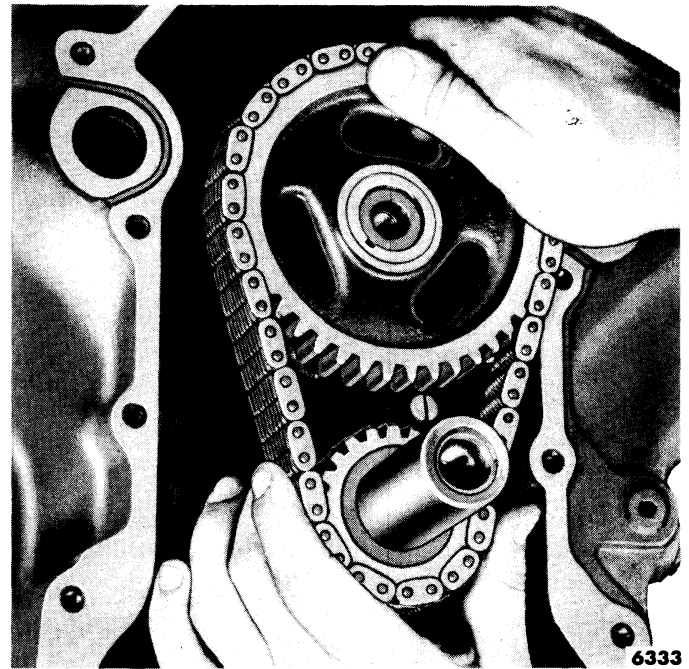

Fig. 23—Removing or Installing Timing Chain and Sprockets

Crank the engine until the timing marks on the sprockets and chain are positioned as shown in fig. 22. Remove the distributor cap, and scribe a line on the distributor housing and cylinder block to mark the position of the rotor and distributor housing for installation, then remove the distributor.

Remove the camshaft sprocket bolt, fuel pump ec-

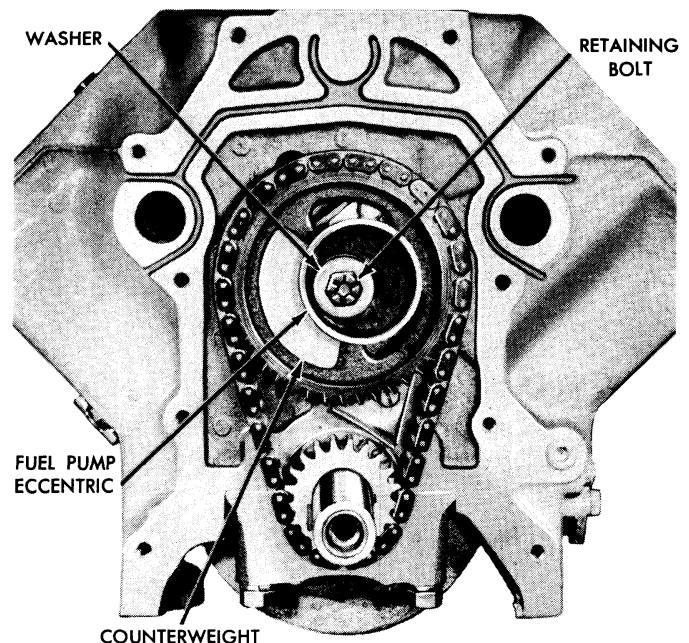
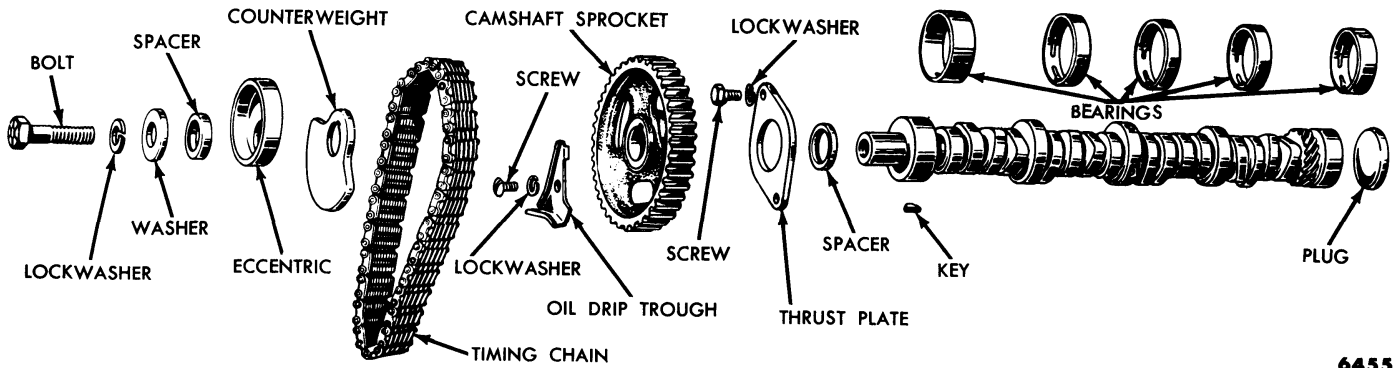

Fig. 24—Fuel Pump Eccentric and Counterweight Installed—Typical



6455

Fig. 25—Camshaft and Related Parts

centric, and counterweight.

Remove the sprockets and timing chain as an assembly. Remove the camshaft thrust plate, woodruff key, and spacer (fig. 26).

Turn the camshaft until the tappets can be lifted with either a magnet (fig. 27), or the fingers. Raise the tappets clear of the camshaft lobes and secure them with spring-type clothes pins, or window regulator spring clips (figs. 27 and 28).

Carefully remove the camshaft by pulling it toward the front of the engine.

CAUTION: Exercise the necessary caution to avoid damaging the camshaft bearings.

(2) **INSTALLATION.** Oil the camshaft and carefully slide it through the bearings. Install the thrust plate and spacer (fig. 26).

NOTE: Be sure the chamfer on the inside of the spacer is to the rear or faces the camshaft journal when the spacer is installed.

Tighten the retaining bolts to 12-15 foot-pounds torque. Install the woodruff key in the camshaft.

Check the camshaft end play (Chapter I). If the end play is excessive, inspect the spacer for correct installation. Replace the thrust plate and/or spacer if necessary. Install the sprockets and timing chain, counterweight, fuel pump eccentric, spacer, washers, and camshaft sprocket bolt.

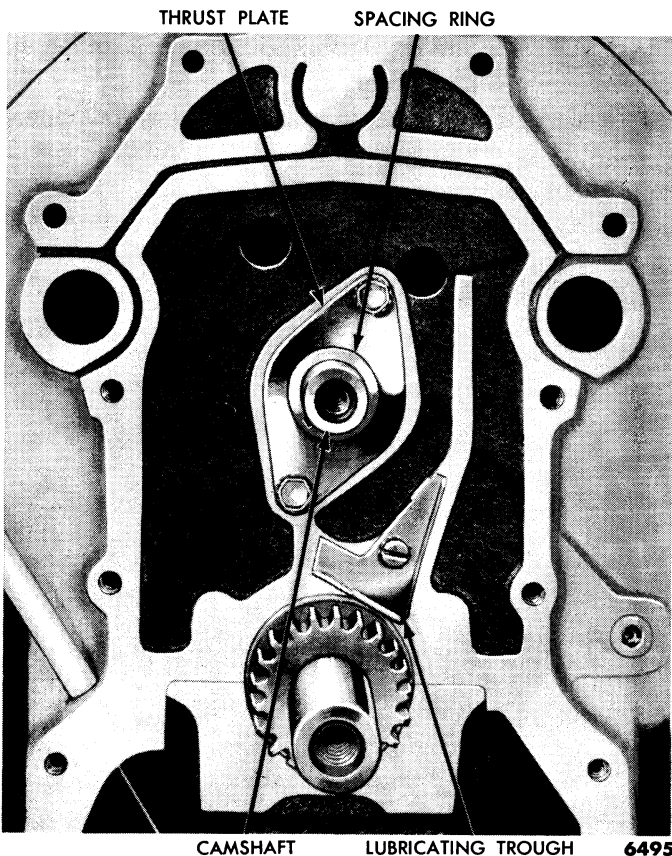

Fig. 26—Camshaft Thrust Plate

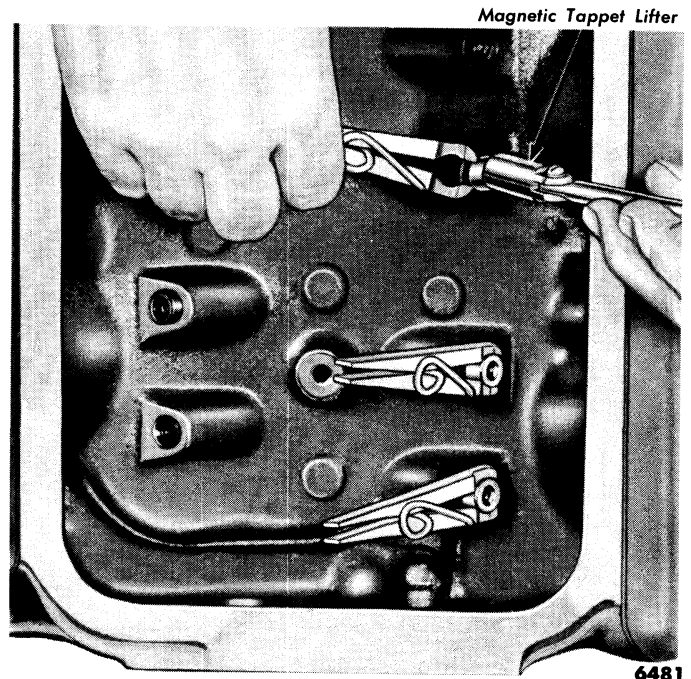

Fig. 27—Lifting and Securing Valve Tappets

Install the cylinder front cover, crankshaft damper, drive belts, and oil pan.

Install the hub and fan blades, fuel pump, radiator, and radiator grille support bracket.

Release the tappets and install the push rods, then install the rocker arm assemblies.

Install the distributor in the cylinder block, using the scribed lines as guides to properly position the rotor and housing. Install the distributor cap.

Install the push rod chamber cover. Install the intake manifold, carburetor, and coil as an assembly. Connect the vacuum lines, fuel lines, and accelerator linkage. Install the carburetor air cleaner. Fill the cooling system and the crankcase.

Make a preliminary (cold) valve lash adjustment. Run the engine for approximately 30 minutes at 1200 r.p.m., then make a final (hot) valve lash adjustment while operating the engine at idle speed. Check for oil and coolant leaks. Install the rocker arm covers. Check and adjust the ignition timing.

c. Tappet Replacement.

Remove the camshaft as outlined in "b." Remove and install one tappet at a time through the bottom of the block. A flexible-type holding tool can be used for this operation. As each tappet is installed, it should be secured in the up position.

After the tappets are installed, install the camshaft as outlined in "b."

d. Bearing Replacement.

It will be necessary to remove the engine from the car to replace camshaft bearings. The bearings are available pre-finished to size for standard and 0.015 inch

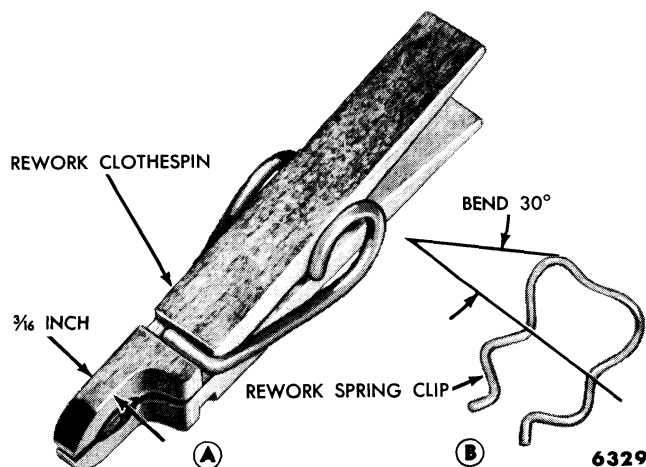

Fig. 28—Tappet Retainers

Tool—T52L-6261-CEE
Remover adapter—T54L-6250-B (Detail No. 2)
Replacer adapter—T54L-6250-B (Detail No. 1)

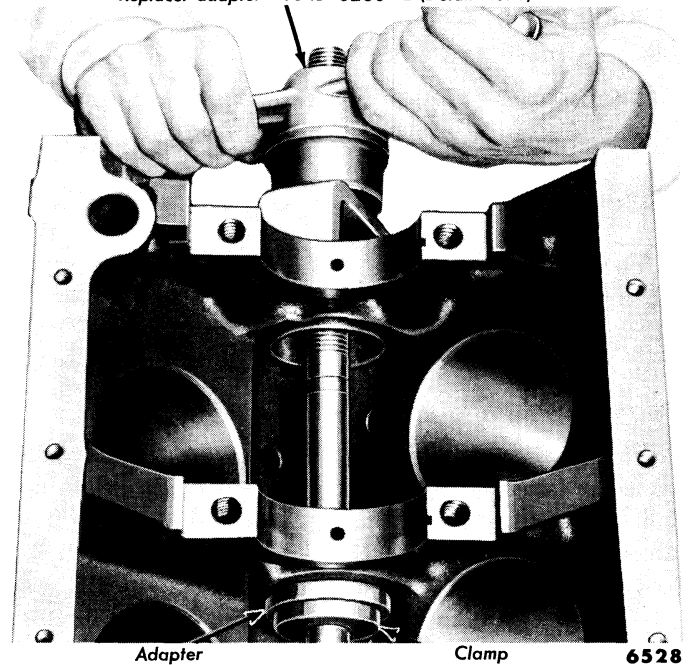

Fig. 29—Camshaft Bearing Removal or Installation

undersize journal diameters. Number 1 bearing is not interchangeable with the other bearings.

Remove the camshaft as outlined in "b." Remove the flywheel and crankshaft. Push the piston to the top of the cylinder to move the connecting rods out of the way. Knock out the camshaft rear bearing bore plug working from the front bearing bore, or drill a 1/2 inch hole in the plug and use Tool-7600-E to remove the plug. Remove the camshaft bearings as outlined in fig. 29.

Position the bearing at the bearing bore, and press it in place with the tool shown in fig. 29. Be sure to align the oil holes in the bearings with the oil holes in the cylinder block when the bearings are installed.

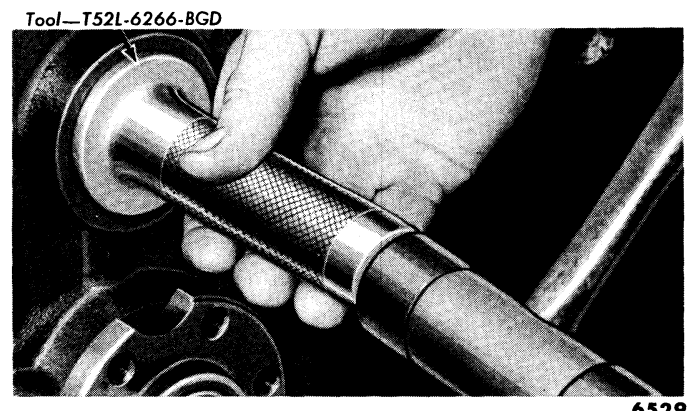

Fig. 30—Camshaft Rear Bearing Bore Plug Installation

NOTE: Be sure the camshaft front bearing is installed 0.005-0.020 inch below the front face of the cylinder block. This will allow proper installation of the thrust plate.

Clean out the plug recess in the camshaft rear bore.

Lightly coat the outer rim of a new plug with sealer. Install the plug with the tool shown in fig. 30.

Install the camshaft as outlined in "b." Install the crankshaft, and flywheel, then install the engine in the car.

8. FLYWHEEL, CRANKSHAFT, AND MAIN BEARINGS

The crankshaft and related parts are shown in fig. 31. The procedure for replacing the clutch pilot bushing is covered in Part TWO.

a. Flywheel.

The flywheel is piloted on a shoulder and is retained on the crankshaft by six bolts. The flywheel can be bolted to the crankshaft in only one position as the bolt holes are unequally spaced. The ring gear is a shrink fit on the flywheel.

On standard or overdrive equipped cars, the rear face of the flywheel is used as a friction surface which is en-

gaged by the clutch disc. The flywheel can be removed and installed with the engine mounted in the car.

The flywheel used on Fordomatic equipped cars has two laminated spring-steel drive plates riveted to the outer edge 180° apart, to which the converter cover is attached.

The following removal and installation procedures apply to all cars, except a Fordomatic equipped Thunderbird. The Fordomatic cannot be removed as a separate assembly from the Thunderbird; therefore, it will be necessary to remove the engine from the car in order to replace the flywheel.

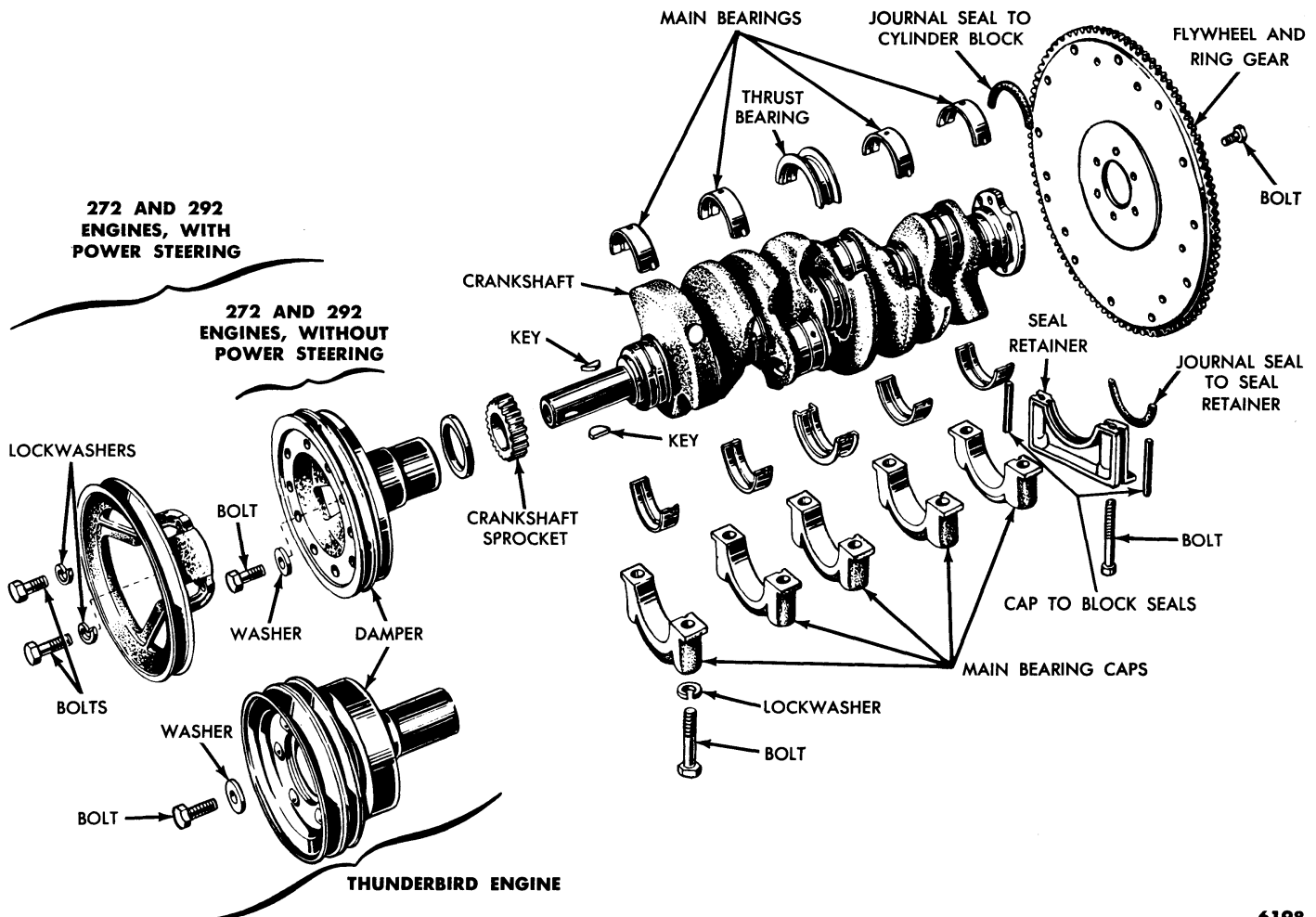

Fig. 31—Crankshaft and Related Parts

(1) **REMOVAL — STANDARD OR OVERDRIVE TRANSMISSION.** Remove the transmission. Remove the flywheel housing dust cover. Mark the clutch assembly so it can be replaced in the same position. Remove the clutch release rod, spring, and bearing. Remove the clutch pressure plate and disc (Tool-7563). Remove the six flywheel retaining bolts, then remove the flywheel.

CAUTION: *Do not get grease or oil on the clutch components.*

(2) **INSTALLATION — STANDARD OR OVERDRIVE TRANSMISSION.** Position the flywheel on the crankshaft and align the bolt holes, then install the mounting bolts. Tighten the bolts alternately and evenly, to seat the flywheel, to 75-85 foot-pounds torque. Using a pilot shaft to locate the clutch disc, install the pressure plate and disc. Install the clutch release rod, bearing, spring, and hub. Install the flywheel housing dust cover. Install the transmission.

(3) **REMOVAL—FORDOMATIC.** Remove the two rubber plugs from the floor pan, then remove the converter housing to engine block upper bolts. Raise the front of the car and position safety stands. Remove the transmission control linkage shield, the torque converter lower access plate, the torque converter air inlet shield, and the torque converter front access plate. Turn the torque converter until the drain plug is at the lower edge. Drain the transmission and the torque converter.

Remove the drive shaft. Disconnect the speedometer cable and transmission control rod at the transmission. Remove the battery cable from the starter, then remove the starter. Remove the transmission oil level indicator tube.

Install the drain plug in the torque converter. Position a jack under the transmission. Remove the transmission support bolts. Remove the frame cross member at the rear of the transmission. Remove the two lower bolts securing the torque converter housing to the engine block. Move the transmission back far enough to clear the flex drive plate. Secure the torque converter to the housing.

CAUTION: *If the torque converter is not secured, it will slide off the splines.*

Remove the flex drive plate from the crankshaft.

(4) **INSTALLATION—FORDOMATIC.** Position the flex drive plate on the crankshaft and align the bolt holes, then install the mounting bolts. Tighten the bolts to 75-85 foot-pounds torque. Align the converter pilot and the housing dowel holes, then install the torque converter housing to engine block lower bolts. Install the flex plate to converter bolts. Install the frame cross member. Remove the jack. Install the transmission rear support bolts.

Connect the transmission throttle control linkage, the manual control linkage, and the speedometer cable. Install the torque converter air inlet shield, control linkage shield, torque converter housing front access cover, the torque converter lower access cover, and the oil level indicator tube.

Install the starter, then connect the battery cable to the starter. Install the drive shaft. Remove the safety stands. Install the converter housing to engine block bolts. Install the rubber plugs and position the floor mat.

Fill the transmission with fluid. Start the engine to fill the torque converter, then add fluid until the proper level is reached. Check for leaks. Check and adjust the manual control, the neutral switch, and the throttle linkage.

b. Crankshaft.

The crankshaft is made from a cast iron alloy. It has integral counterweights and is statically and dynamically balanced.

NOTE: *Handle the crankshaft with care to avoid possible fractures or damage to the finished surfaces.*

(1) **REMOVAL.** Remove the engine from the car and mount it on an engine stand. Drain the oil. Remove the generator and fuel pump. Remove the oil pump and intermediate shaft, then remove the oil pan and oil inlet pipe as an assembly. Remove the crankshaft damper. Remove the cylinder front cover with the fan and water pump as an assembly. Remove the crankshaft damper spacer, and woodruff key. Remove the sprockets and the timing chain. Remove the clutch assembly and the flywheel, or the flex drive plates. Remove the crankshaft rear oil seal retainer. Remove the connecting rod bearing caps, using care not to intermix the caps, then carefully push the piston and rod assemblies against the head.

Remove the main bearing caps, and mark them for installation on the same journals. Carefully lift the crankshaft out of the cylinder block so the thrust bearing surfaces are not damaged. Be sure all parts are identified so they can be installed in their original positions.

(2) **INSTALLATION.** Be sure that all bearings and the crankshaft journals are clean. Install a new rear journal oil seal in the block and rear journal oil seal retainer. Carefully lower the crankshaft into place.

CAUTION: *Be careful not to damage the bearing surfaces.*

Check the clearance of each main bearing using Plastigage (Chapter I). After the clearance has been checked and found to be satisfactory, apply a light coat of engine oil to the journals and bearings, then install

all the bearing caps, except the thrust bearing cap. Install the thrust bearing cap and draw the cap bolts up lightly, then align the thrust bearing (Chapter I). Tighten the cap bolts to specifications. Install the rear bearing oil seal retainer and new side seals. Check the crankshaft end play (Chapter I).

Check the connecting rod bearing clearance, using Plastigage (Chapter I). After the clearance has been checked and found to be satisfactory, apply a light coat of engine oil to the journals and bearings, then install the rod caps. Tighten all the nuts to 45-50 foot-pounds torque. Install the pal nuts and tighten them to 3-4 foot-pounds torque. Check the end play of each connecting rod (Chapter I).

Install the flywheel and the clutch assembly, or the flex drive plate. Install the sprockets and the timing chain, counterweight, fuel pump eccentric, spacer, washers, and camshaft sprocket bolt.

Install the cylinder front cover, crankshaft damper, fuel pump, generator, and drive belts. Install the oil pan, oil pump, and oil pump inlet tube.

Install the engine in the car.

Install the hub and fan blades. Install the radiator, then fill the cooling system and crankcase. Operate the engine and check for oil and coolant leaks. Check and adjust the ignition timing.

c. Main Bearings.

The main bearings are the steel-backed, copper-lead, or lead-babbitt insert-type.

If the crankshaft has been removed, new bearings can

be readily fitted. However, the bearings can be fitted with the engine in the chassis, as follows:

Remove the oil pan.

NOTE: *Replace one bearing at a time, leaving the other bearings securely fastened.*

Remove the main bearing cap to which new bearings are to be fitted. Insert the upper bearing removal tool (Tool-6331) in the oil hole in the crankshaft. Rotate the crankshaft in the opposite direction to engine rotation to force the bearing out of the block.

NOTE: *When replacing standard bearings with new bearings, it is good practice to first try to obtain the proper clearance with two blue bearing halves.*

To install the upper main bearing, place the plain end of the bearing over the shaft on the locking tang side of the block. Using the same tool, rotate the crankshaft in the direction of engine rotation until the bearing seats itself. Remove the tool. Replace the cap bearing.

Clean the crankshaft journal and bearings. Check the bearing clearance using Plastigage (Chapter I). After the clearance has been checked and found to be satisfactory, apply a light coat of engine oil to the journals and bearings, then install the bearing cap. Tighten the bolts to specifications.

If the rear bearing oil seal retainer is removed, replace the crankshaft journal oil seals, and use new side seals when the retainer is installed.

Install the oil pan. Fill the crankcase, then start the engine and check for oil pressure and oil leaks.

9. CONNECTING RODS AND BEARINGS, PISTONS, PINS, AND RINGS

The piston and connecting rods are shown disassembled in fig. 32.

a. Piston and Connecting Rod Removal.

Remove the oil pan and cylinder heads. Before re-

moving the piston assemblies, remove any ridge and/or carbon deposits from the upper end of the cylinder bores. Move the piston to the bottom of its travel and place a cloth on the piston head to collect the cuttings. Remove the cylinder ridge with a ridge cutter. Follow the instructions furnished by the tool manufacturer.

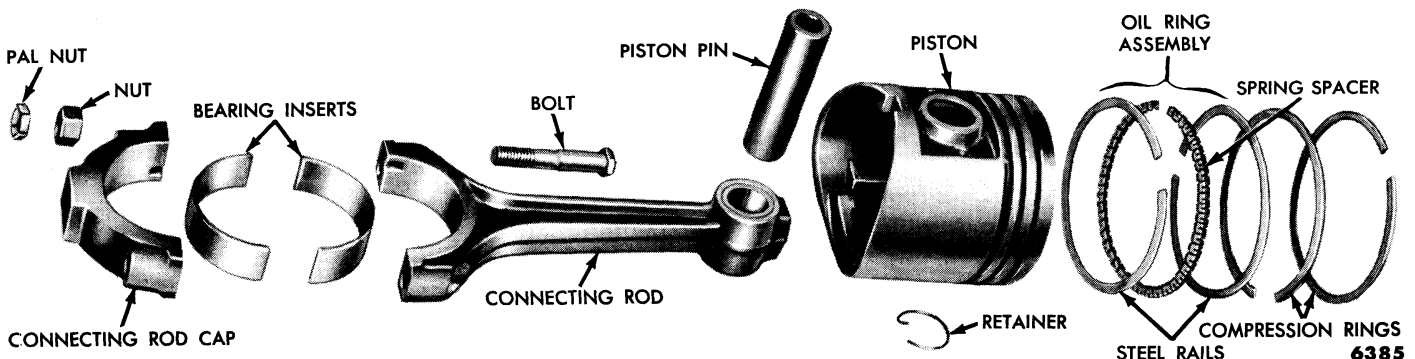

Fig. 32—Piston and Connecting Rod Disassembled—Typical

CAUTION: *Never cut into the ring travel area in excess of 1/32 inch when removing ridges.*

After the ridge has been removed, remove the cutter from the cylinder bore, then turn the crankshaft until the piston is at the top of its stroke and carefully remove the cloth with the cuttings.

Turn the crankshaft until the connecting rod being removed is down. Remove the pal nuts and the hex head nuts from the connecting rod bolts. Pull the cap off the rod, then push the rod and piston assembly out the top of the cylinder with the handle end of a hammer.

CAUTION: *Avoid damage to the crankpin or the cylinder wall when removing the piston and rod.*

Remove the glaze from the cylinder wall (Chapter I).

Repeat this procedure for each assembly.

NOTE: *Connecting rod and bearing cap assemblies are numbered from 1 to 4 in the right bank and from 5 to 8 in the left bank, beginning at the front of the engine. The numbers on the rod and bearing cap must be on the same side when installed in the cylinder bores. If a connecting rod is ever transposed from one block or cylinder to another, new bearings should be fitted and the rod should be numbered to correspond with the new cylinder number.*

b. Piston and Connecting Rod Disassembly.

Mark the pistons and pins to assure assembly with the same rod and installation in the same cylinder from which they were removed. Remove the piston rings.

Remove the piston pin retainers, then drive the pins out of the piston and rod (fig. 33). Discard the retainers.

c. Piston and Connecting Rod Assembly.

Lubricate all parts with light engine oil.

NOTE: *Assemble the connecting rods and pistons as shown in fig. 34.*

Position the connecting rod in the piston and push the pin into place.

Insert new piston pin retainers by spiraling them into the piston with the fingers. Do not use pliers.

Follow the instructions contained in the piston ring package and install the piston rings.

Be sure the bearings and journals are clean. If it is necessary to replace the connecting rod bearings, replace them at this time.

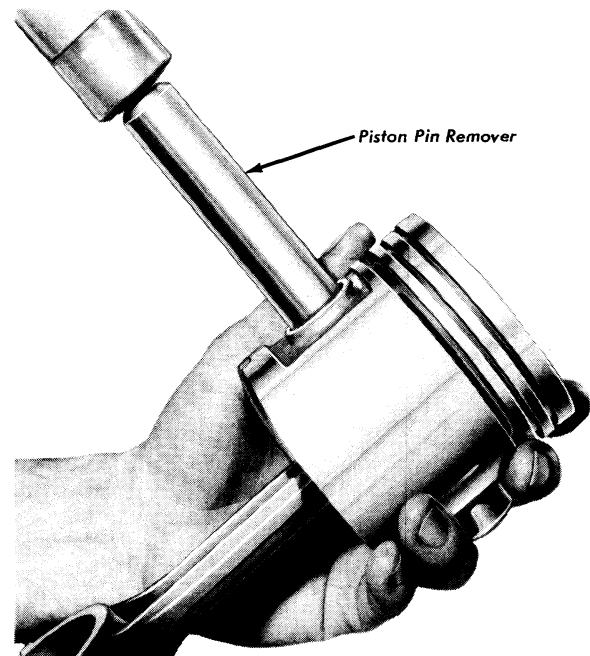

Fig. 33—Piston Pin Removal

6386

d. Piston and Connecting Rod Installation.

Oil the piston rings, pistons, and cylinder walls with heavy engine oil.

NOTE: *Be sure to install the pistons in the same cylinders from which they were removed, or to which they were fitted.*

Make sure the ring gaps are properly spaced around the circumference of the piston. Install a piston ring compressor on the piston and push the piston in with a hammer handle (fig. 35) until it is slightly below the top of the cylinder. Be sure to guide the connecting rods to avoid damaging the crankshaft journals.

NOTE: *Install the piston with the indentation in the piston head toward the front of the engine. When installed, the rod bearing lock slots in the connecting rod should be toward the outside of the engine.*

Check the bearing clearance using Plastigage (Chapter I). After the clearance has been checked and found to be satisfactory, apply a light coat of engine oil to the

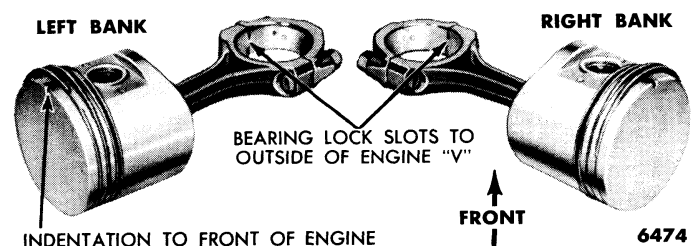

Fig. 34—Connecting Rod and Piston Assembly

6474

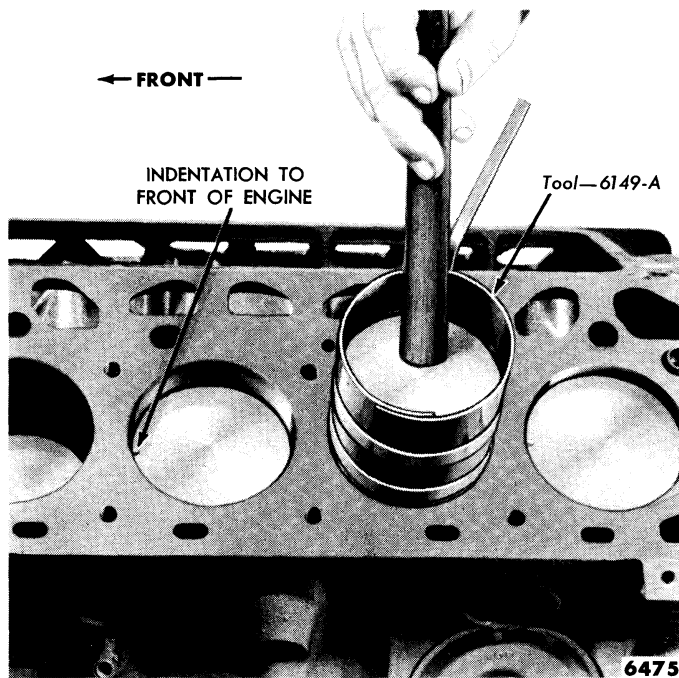

Fig. 35—Piston Installation

journals and bearings. Turn the crankshaft throw to the bottom of its stroke, then push the piston all the way down until the rod bearing seats on the crankpin. Install the rod cap, then tighten the bolts to 45-50 foot-pounds torque. Install the pal nuts and tighten them to 3-4 foot-pounds torque.

After the piston and rod assemblies have been installed, check the end play of the connecting rods (Chapter I).

Install the oil pan, cylinder heads, and manifold. Fill

the crankcase with the proper grade and quantity of engine oil. Fill the cooling system. Run the engine at fast idle. Make sure there is sufficient oil pressure and the engine does not overheat. Check for oil and coolant leaks.

e. Connecting Rod Bearing Replacement.

If the engine is removed from the car and mounted on a stand, new bearings can be readily fitted. However, the bearings can be fitted without removing the engine, as follows:

Remove the oil pan.

Remove the cap from the connecting rod to which new bearings are to be fitted. Push the piston up in the cylinder, then remove the upper and lower bearings. Clean the crankshaft journals, the cap, and the upper half of the bearing bore.

NOTE: *When replacing standard bearings with new bearings, it is good practice to first try to obtain the proper clearance with two blue bearing halves.*

Install the new bearings in the rod and cap. Check the fit using Plastigage (Chapter I). After the bearing fit has been checked and found to be satisfactory, apply a light coat of engine oil to the journals and bearings, then install the rod cap. Tighten the bolts to 45-50 foot-pounds torque, then install the pal nuts, and tighten them to 3-4 foot-pounds torque. Repeat the procedure for the remaining rods that require new bearings.

After all the bearings that required replacement have been replaced, install the oil pan. Fill the crankcase, then operate the engine and check for oil pressure and oil leaks.

10. OIL PAN, OIL FILTER, AND OIL PUMP

Procedures for the removal and installation of the above components are presented below.

a. Oil Pan.

The oil pan is sealed to the cylinder block by a one-piece cork gasket. A screen assembly, located in the oil pan sump, screens the oil before it flows to the pump. Oil enters the inlet side of the pump through an external pick-up tube.

NOTE: *On the Thunderbird engine, the sump is at the rear of the oil pan, while on the Police Interceptor and passenger car engine it is at the front.*

The oil inlet screen cover and oil pump inlet tube assembly is a one-piece design. It is assembled to the oil pan from the inside by inserting the tube through the hole in the side of the pan. A threaded fitting, which is

welded to the tube, projects through the hole in the pan and the tube fitting gasket and nut secures and seals the tube to the pan.

(1) **REMOVAL.** Remove the oil level indicator. Drain the crankcase. Remove the engine front splash pans (except on the Thunderbird). On Fordomatic equipped cars, remove the converter housing cover assembly. Disconnect the oil pump inlet tube at the oil pump. Remove the "O" ring seal from the pump end of the tube. Remove the oil pan retaining screws and nuts, then remove the oil pan.

NOTE: *On all cars except the Thunderbird, number 5 cylinder must be at approximately top dead center before the oil pan can be removed.*

Remove the nut securing the inlet tube to the oil pan, then remove the oil pump screen and tube assembly from the oil pan.

(2) **INSTALLATION.** Make sure the gasket surfaces of the oil pan and block are clean and free of burrs.

Fasten the oil pump screen to the cover and tube assembly with the screen retainer.

Insert the tube through the hole in the side of the oil pan from the inside of the pan. Coat the inlet tube to oil pan nut with oil resistant sealer, then install a new washer and the nut. Do not tighten the nut at this time.

Coat the cylinder block oil pan gasket surface with oil resistant sealer.

Position a new gasket on the oil pan, hold the pan in place against the block, and install two of the retaining screws on each side of the pan. Install the remaining screws, and tighten them, from the center outward to 12-15 foot-pounds torque. If the car is equipped with Fordomatic, install the converter housing cover assembly.

Install a new "O" ring seal on the pump end of the tube, then install the tube and seal in the pump. Tighten the jam nut at the oil pump to 10-12 foot-pounds torque and the nut at the oil pan to 28-32 foot-pounds torque.

CAUTION: Do not overtighten the inlet tube nuts.

Install the engine front splash pans (except on the Thunderbird). Install the oil level indicator. Fill the crankcase with the proper amount and grade of lubricant.

b. Oil Filter.

The full flow-type oil filter (fig. 36), filters the entire output of the pump before the oil enters the engine lubrication system.

A built in by-pass provides oil to the system in case the filter element becomes clogged. The by-pass is located in the hollow center bolt and consists of a spring loaded valve. When the element is clean and oil will flow through it, the pressure difference between the inner and outer faces of the valve is not great enough to overcome the spring pressure behind the valve. Therefore, no oil flows through the by-pass. When the element is dirty and will not permit a sufficient flow of oil, the oil pressure acting on the inner face of the valve drops. If the pressure difference between the valve faces is great enough to overcome spring pressure, the valve will open. Oil then by-passes the element, thereby main-

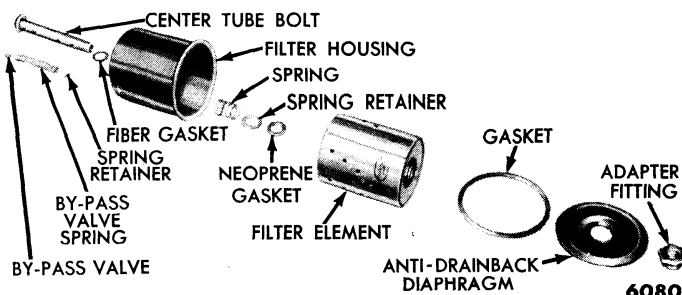

Fig. 36—Oil Filter Disassembled

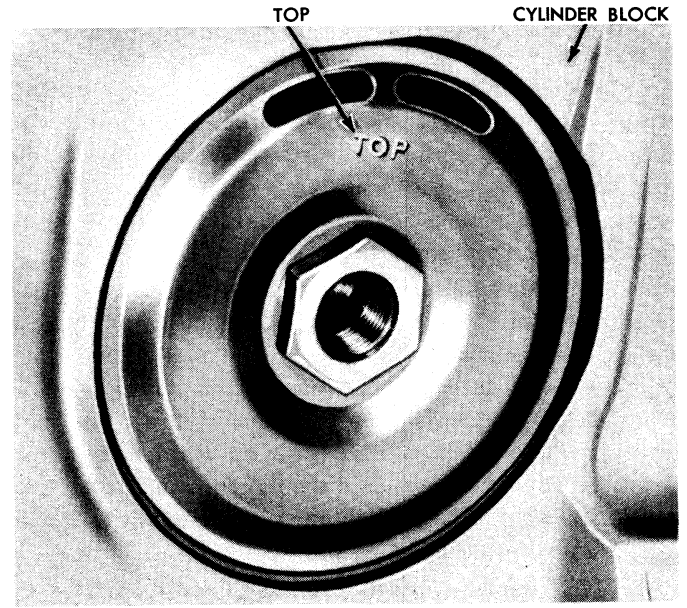

Fig. 37—Oil Filter Anti-Drain Back Diaphragm Position

taining an emergency supply of oil to the engine lubrication system until the source of restriction to the normal oil flow is corrected.

(1) **REMOVAL.** The filter is removed from the bottom of the car. Put the car on a hoist or jack up the front of the car.

NOTE: On cars equipped with power steering, turn the front wheels to the full right position to facilitate removal of the oil filter.

Place a drip pan under the filter. Remove the filter center bolt, then remove the filter assembly and gasket.

(2) **DISASSEMBLY.** Remove the filter element, neoprene gasket, spring, and seat. Remove the center bolt from the container and the fiber gasket from the bolt. Discard the filter element and all gaskets. Wash

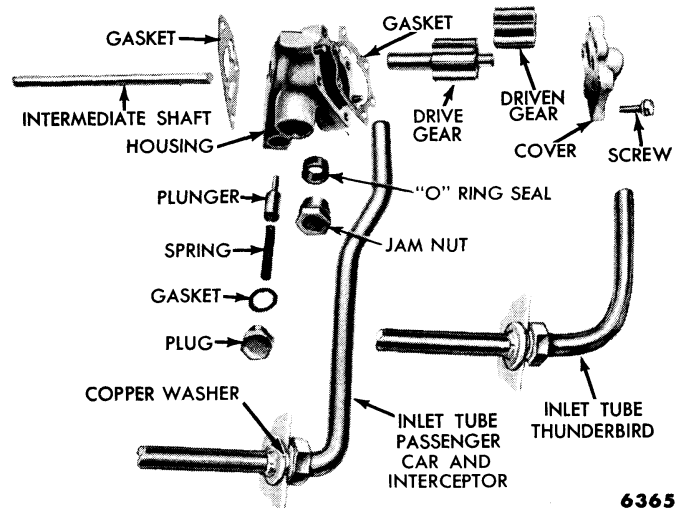

Fig. 38—Oil Pump Disassembled

all parts in solvent. Make sure all the openings in the center bolt are clean.

(3) **ASSEMBLY.** Install a new fiber gasket on the center bolt, then place the bolt through the filter container. Install the spring and spring seat assembly on the bolt, making sure the seat tangs are engaged in the spring. Install a new neoprene gasket and a new filter element over the center bolt.

(4) **INSTALLATION.** Check to see if the two elongated holes in the oil filter anti-drain back diaphragm are in the up position as shown in fig. 37. Clean the cylinder block filter recess, then install a new gasket. Place the filter assembly in position, and thread the center bolt into the adapter finger-tight. Rotate the filter assembly slightly, in each direction, to make sure the gasket is seated evenly. Tighten the center bolt to 20-25 foot-pounds torque.

CAUTION: Do not overtighten the center bolt.

Refill the crankcase with oil if necessary, then operate the engine at fast idle, and check for leaks. If oil leaks are evident, perform the necessary repairs to correct the leakage.

c. Oil Pump.

The gear-type oil pump (fig. 38) is externally mounted on the lower left corner of the engine. It is driven by the distributor shaft through an intermediate hex-shaped shaft. An external inlet tube picks up the oil from the pan and transfers it to the inlet side of the pump.

(1) **REMOVAL.** Disconnect the oil inlet tube at the pump and loosen the tube at the pan. Remove the three cap screws and lockwashers securing the pump body to the block. Remove the pump, intermediate shaft, pump to block gasket, and the tube to pump "O" ring seal.

(2) **DISASSEMBLY.** Remove the four cap screws retaining the pump cover to the pump body. Remove the cover plate and gasket. Do not tap the pump drive shaft to remove the cover. Remove the oil pump gear and shaft assembly and the idler gear. Remove the oil pressure relief valve chamber plug, gasket, spring, and plunger.

(3) **ASSEMBLY.** Oil all parts thoroughly. Install the oil pressure relief valve plunger, spring, plug, and gasket. Install the idler gear and drive gear. Check the end play of the gears using Plastigage or a dial indicator (Chapter I). Apply sealer to both sides of the pump cover gasket, then position the gasket on the pump. Install the cover plate, then tighten the cover screws to 12-15 foot-pounds torque.

(4) **INSTALLATION.** Insert the intermediate shaft into the oil pump drive shaft. Install a new "O" ring seal on the pump end of the tube, then install the tube and seal in the pump. Using a new gasket coated with sealer, position the pump on the block.

CAUTION: Do not attempt to force the pump into position if it will not seat readily. The intermediate shaft hex may be misaligned with the distributor shaft. To align, rotate the intermediate shaft into a new position.

Tighten the oil pump retaining screws alternately to 12-15 foot-pounds torque. Tighten the oil inlet tube to oil pump jam nut to 10-12 foot-pounds torque, and tighten the oil tube to oil pan nut to 28-32 foot-pounds torque.

CAUTION: Do not overtighten the inlet tube nuts.

Run the engine at fast idle and check for oil pressure and oil leaks.

II. EXHAUST SYSTEM

The single exhaust system is standard on Mainline and Customline models.

A dual exhaust system is standard on the Interceptor, Thunderbird, Station Wagon, and Fairlane models. The dual exhaust system is also installed on other models as optional equipment. This system consists of two muffler inlet pipes, two mufflers, and two outlet pipes.

NOTE: The Thunderbird has a 2-piece outlet pipe.

The dual exhaust system is designed to facilitate rapid scavenging of the exhaust gases, thereby minimizing exhaust gas back pressure. The Thunderbird exhaust system is shown in fig. 39.

Inlet pipes, mufflers, outlet pipes, and outlet pipe extensions (Thunderbird) are provided as individual service parts.

The procedures given apply to all models and to both right and left assemblies on dual exhaust equipped cars,

unless otherwise stated. The outlet pipe replacement procedure for the Thunderbird varies slightly because of the two-piece outlet pipe.

NOTE: When replacing any part of the exhaust system, loosen all the frame attaching bracket clamps to relieve twists in the system, then tighten the clamps.

a. Muffler Replacement.

Extra heavy, double-wall constructed mufflers are available for service.

(1) **PASSENGER CARS AND POLICE INTERCEPTOR UNIT.** Loosen the outlet pipe to frame rear clamp. Loosen the muffler inlet pipe clamp. Slide the clamps away from the muffler. Remove the lower half of the clamp at the rear of the muffler. Separate the muffler and outlet pipe by sliding the outlet pipe to the

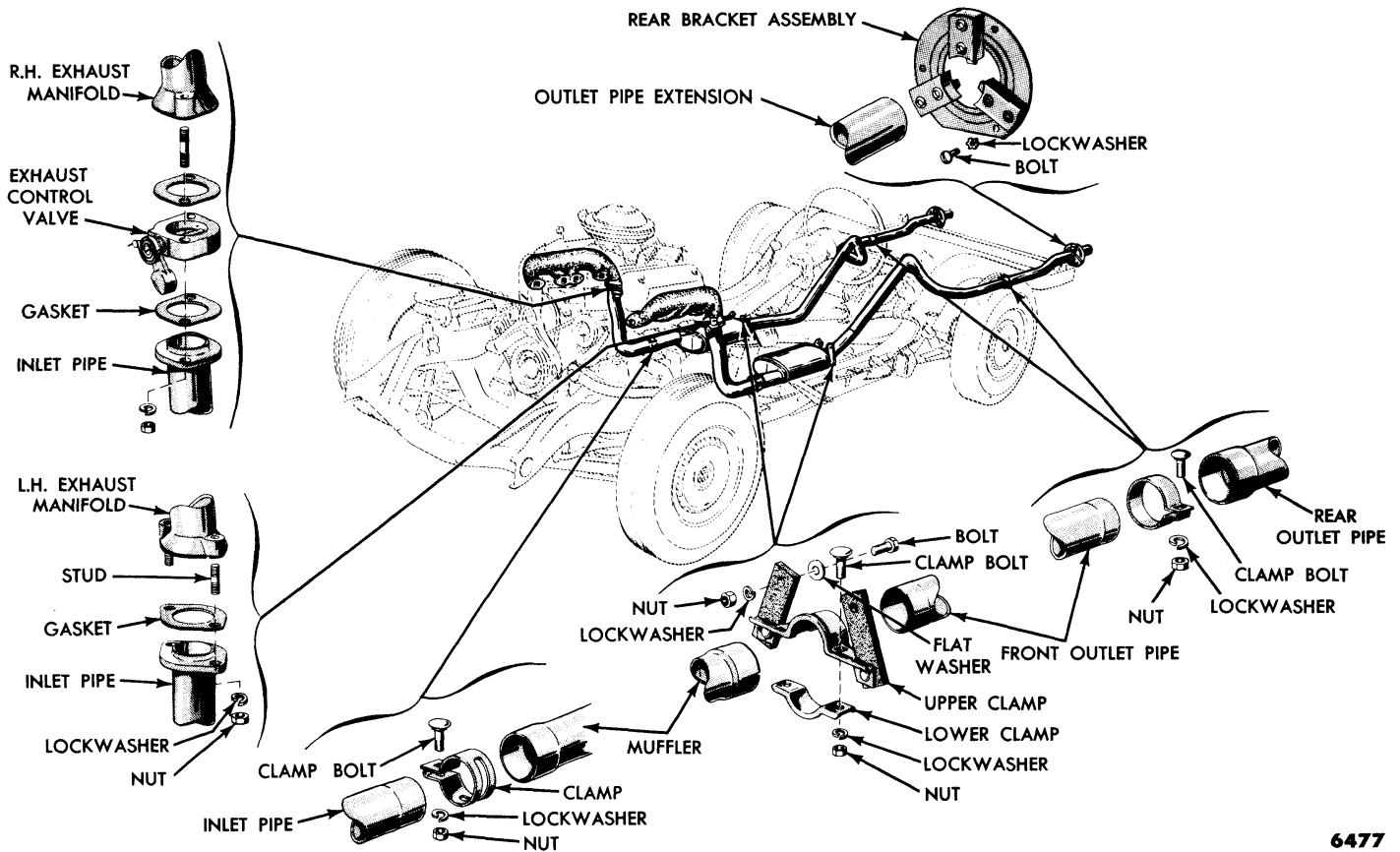

Fig. 39—Dual Exhaust System—Thunderbird

6477

rear. Separate the muffler from the inlet pipe and remove the muffler.

Position the new muffler and clamp on the inlet pipe. Slide the muffler forward on the inlet pipe until the slots in the muffler extension are blocked. The overlap must not be greater than $1\frac{3}{4}$ inches. Align the muffler. Rotate the front clamp downward approximately 45° so the clamp opening is not positioned directly opposite the slots in the extension. Tighten the front clamp.

Slide the outlet pipe forward into the muffler extension until the slots in the extension are blocked. Do not insert the pipe more than $1\frac{3}{4}$ inches into the muffler. Connect, but do not tighten, the lower half of the clamp at the rear of the muffler. Check for possible interference between the outlet pipe "kick-up" and the floor pan. Reposition the outlet pipe if necessary. Tighten all the clamps.

(2) **THUNDERBIRD.** Remove the lower half of the clamp at the rear of the muffler. Loosen the clamp at the junction of the front and rear outlet pipes and slide the clamp to the rear. Separate the front and rear outlet pipes. Remove the front outlet pipe from the muffler. Slide the clamp forward on the inlet pipe. Remove the inlet pipe (and the exhaust gas control valve with the right inlet pipe) from the exhaust manifold. Remove

the muffler from the inlet pipe.

Position the new muffler on the inlet pipe. Install the inlet pipe (and the exhaust gas control valve with the right inlet pipe) on the exhaust manifold. Tighten the retaining nuts to 23-28 foot-pounds torque. Slide the muffler forward on the inlet pipe until the slots in the muffler extension are blocked by the inlet pipe. The overlap must not be greater than $1\frac{3}{4}$ inches. Rotate the front clamp downward approximately 45° so the clamp opening is not positioned directly opposite the slots in the extension. Tighten the front clamp.

Install the front outlet pipe in the muffler. Connect the front and rear outlet pipes. Slide the outlet pipe forward into the muffler extension until the slots in the extension are blocked. Do not insert the pipe more than $1\frac{3}{4}$ inches into the muffler. Check for possible interference between the front outlet pipe "kick-up" and the floor pan. Reposition the front outlet pipe if necessary. Tighten the clamp at the front and rear outlet pipe junction. Install the lower half of the clamp at the rear of the muffler.

b. Outlet Pipe Replacement.

The outlet pipe is attached to the frame by flexible sound-deadening clamps. These clamps not only prevent

the exhaust noises from being conducted through the chassis frame, but also relieve the exhaust system from twisting or bending stresses.

(1) **PASSENGER CARS AND POLICE INTERCEPTOR.** Loosen the outlet pipe to frame clamp. Remove the lower half of the clamps at the rear of the muffler, then separate the outlet pipe and the muffler. Remove the outlet pipe.

Position the outlet pipe to frame clamp on the new outlet pipe, then slide the pipe into the muffler until the slots in the muffler extension are blocked. Do not insert the pipe more than 1¾ inches into the muffler. Connect, but do not tighten, the lower half of the clamp at the rear of the muffler. Connect, but do not tighten, the outlet pipe to frame clamp.

Check for possible interference between the outlet pipe "kick-up" and the floor pan. Reposition the outlet pipe if necessary. Tighten all clamps.

(2) **THUNDERBIRD.** Loosen the clamp at the junction of the front and rear outlet pipes and slide the clamp to the rear. Separate the front and rear outlet pipes. Remove the lower half of the clamp at the rear of the muffler. Separate the front outlet pipe and the muffler, then remove the front outlet pipe. Remove the rear outlet pipe from the rear bumper guard retainer.

Position the outlet pipe to frame clamp on the rear outlet pipe. Position the rear outlet pipe in the rear bumper guard retainer. Slide the front outlet pipe into the muffler until the slots in the muffler extension are blocked. Do not insert the pipe more than 1¾ inches into the muffler. Connect, but do not tighten, the lower half of the clamp at the rear of the muffler. Connect the front and rear outlet pipes. Connect, but do not tighten, the clamp at the front and rear outlet pipe junction.

Check for possible interference between the front outlet pipe "kick-up" and the floor pan. Reposition the front outlet pipe if necessary. Tighten all clamps.

c. Inlet Pipe Replacement.

The muffler inlet pipe is designed to give the exhaust gases leaving the exhaust manifolds a direct through passage to the muffler, thereby increasing the over-all efficiency of the exhaust system.

(1) **PASSENGER CARS AND POLICE INTERCEPTOR.** On single exhaust equipped cars, or to replace the left inlet pipe from a dual exhaust, proceed as follows:

Loosen the muffler inlet pipe clamp. Disconnect the inlet pipe at the exhaust manifold and remove it from the muffler. Remove the muffler inlet pipe through the bottom of the car.

Position the muffler inlet pipe and clamp on the muffler. Slide the muffler forward on the inlet pipe until the slots in the muffler extension are blocked by the inlet pipe. The overlap should not be greater than 1¾ inches. Align the muffler. Install the inlet pipe to exhaust manifold nuts and lockwashers, then tighten them to 23-28 foot-pounds torque. Rotate the inlet pipe clamp downward approximately 45° so the clamp opening is not positioned directly opposite the slots in the extension.

To remove the right inlet pipe from a dual exhaust, it is necessary to remove the muffler as previously explained. Upon installation, install the inlet pipe and exhaust gas control valve, then install the muffler as previously explained.

(2) **THUNDERBIRD.** Remove the muffler. Remove the inlet pipe (and the exhaust gas control valve on the right inlet pipe) from the bottom of the car.

Position a new inlet pipe (and the exhaust gas control valve with the right inlet pipe) on the exhaust manifold. Install the muffler as previously explained.

Part ONE POWER PLANT

Chapter IV

Ignition, Fuel, and Cooling Systems

Section		Page
1	Ignition System	69
2	Distributor Minor Repair and Adjustments	74
3	Distributor Overhaul	78
4	Carburetor Operation and Adjustments—Single and Dual Carburetors	84
5	Single Barrel Carburetor Overhaul	89
6	Dual Carburetor Overhaul	92
7	Four-Barrel Carburetor Operation, Adjustments, and Overhaul	95
8	Fuel Pumps, Vacuum Booster, and Fuel Filter	108
9	Fuel Tanks and Lines	110
10	Fans and Belts	111
11	Water Pumps	112
12	Radiator, Hose, and Thermostat	115

The ignition, fuel, and cooling systems are all necessary components of the engine itself. However, since service on these systems is performed separately from engine service, they have been grouped together in one chapter. Another advantage to this grouping lies in the fact that most quick service operations involve one or more of these systems, and the service information

necessary for performing quick service operations is in one place, arranged in easy-to-find sections as listed above.

The information contained in this chapter pertains to the adjustments, tests, replacements, and repair of the parts which are included in the ignition, fuel, and cooling systems.

I. IGNITION SYSTEM

The ignition system is composed of a primary and a secondary circuit. The battery, ignition switch, primary circuit resistor, primary wiring of the ignition coil, distributor points, and condenser are in the primary circuit. The secondary wiring of the ignition coil, rotor, distributor cap, high tension wires and spark plugs compose the secondary circuit.

Repair, adjustment, and testing procedures for the above components, with the exception of the distributor, are given in this section.

NOTE: *All 1956 vehicles have a negative ground electrical system. Be sure the test equipment is properly connected.*

The primary circuit resistor is mounted next to the ignition coil (fig. 1). The purpose of the resistor is to control high voltage in the primary circuit while the engine is operating. During starting, the resistor is cut out of the circuit allowing the full voltage available from the battery to act upon the primary circuit, thus providing excellent starting qualities.

a. Primary Circuit Resistance Test.

Excessive voltage drop in this circuit will lessen the secondary output of the ignition coil, resulting in hard starting and poor performance.

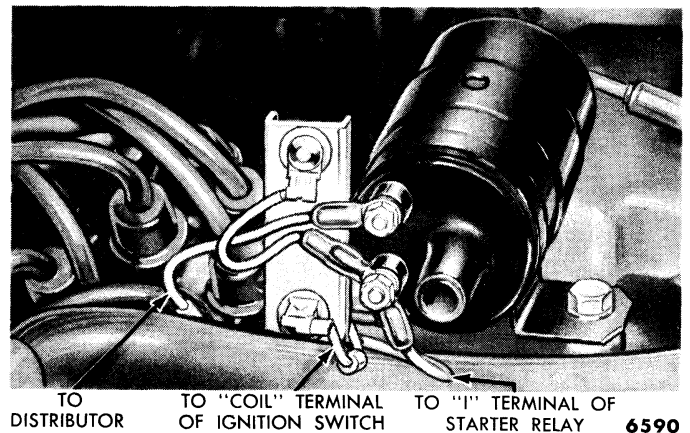

Fig. 1—Resistor Installation—Typical

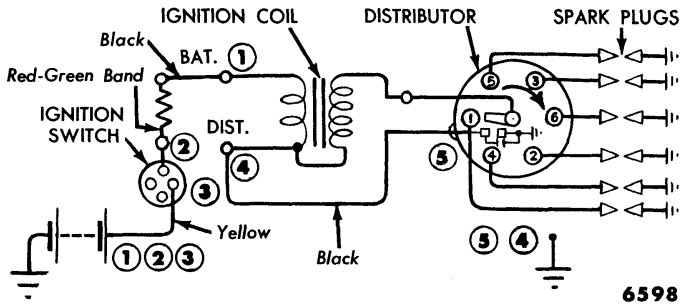

Fig. 2—Ignition Wiring—6-Cylinder Engine

Schematic drawings of the ignition circuit are shown in figs. 2 and 3. The numbers appearing in these drawings establish the order in which the various components are tested.

During the following procedures the ignition switch is on and the distributor points are closed.

(1) **BATTERY TO COIL TEST.** Connect the negative lead of a voltmeter to the battery terminal of the ignition coil resistor (1) and the positive lead to the battery positive terminal (1). The voltmeter should not read more than 0.2 volt. Test the ignition switch by turning it off and on several times. The voltmeter should read the same each time the switch is turned on.

If the voltmeter reading in the battery to ignition coil circuit exceeds 0.2 volts, check each element of the circuit (steps 2 and 3, fig. 2 or 3) until the point of excessive voltage drop is located.

(2) **COIL TO GROUND TEST.** Connect the voltmeter positive lead to the distributor terminal of the coil (4) and the negative lead to the ground (4).

If the voltmeter reading in the coil to ground circuit exceeds 0.1 volt, check each element of the circuit (step 5, fig. 2 or 3) until the point of excessive voltage drop is located.

b. Spark Plugs.

An 18-millimeter spark plug (fig. 4) is used in all

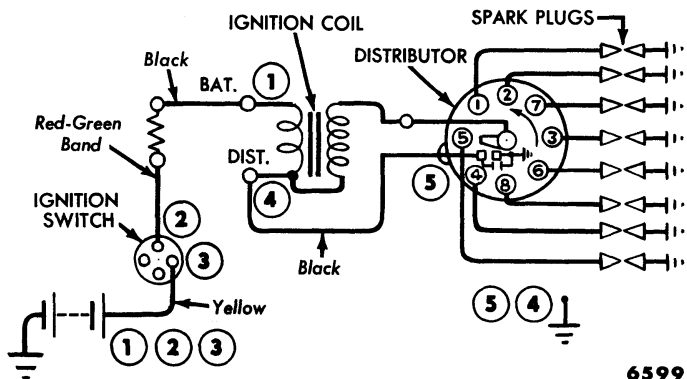

Fig. 3—Ignition Wiring—8-Cylinder Engine

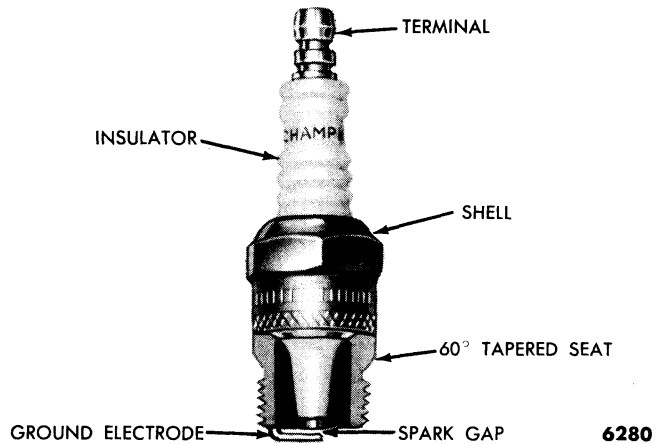

Fig. 4—18-Millimeter Spark Plug

engines. This plug does not require a gasket and is designed to operate efficiently under all conditions.

(1) **REMOVAL.** Pull the wire off each spark plug. Use compressed air to clean the area around each spark plug. Remove the plugs with a spark plug wrench.

(2) **CLEANING AND INSPECTION.** Examine the firing ends of the plugs, noting the type of deposits and the degree of electrode erosion. The various types of spark plug fouling and the normal condition of the spark plug after usage is shown in fig. 5.

Oil fouling (fig. 5) is usually identified by wet, sludgy deposits. These are traceable to excessive oil entering the combustion chamber through worn rings and pistons, excessive clearance between the valve guides and stems, or worn or loose bearings.

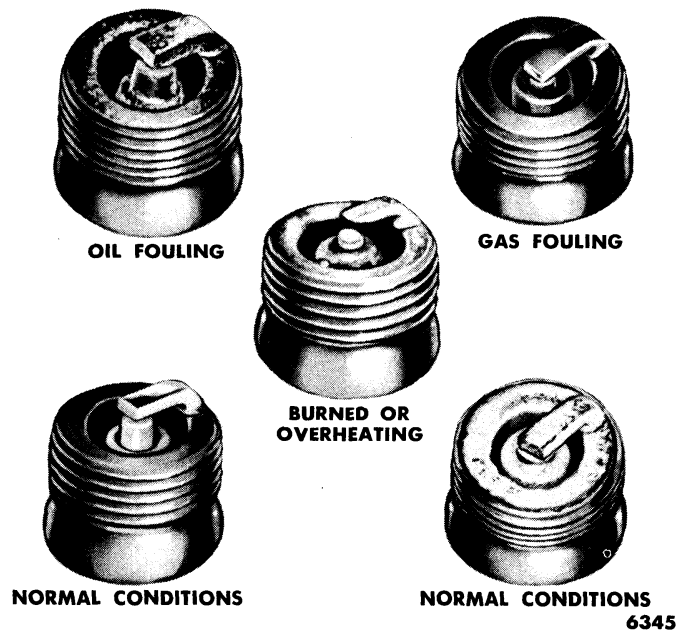

Fig. 5—Visual Inspection—Spark Plugs

Gas fouling (fig. 5) is usually identified by dry, black, fluffy deposits which result from incomplete combustion. Too rich a fuel-air mixture can cause incomplete burning. In addition, a defective coil, defective breaker points, or a defective ignition cable can reduce the voltage supplied to the spark plug and cause mis-firing.

Burned or overheated spark plugs (fig. 5) are usually identified by a white, burned, or blistered insulator nose and badly eroded electrodes. Inefficient engine cooling, improper ignition timing, or the wrong type of fuel can cause general overheating.

Normal conditions (fig. 5 left) where regular or unleaded gasolines have been used are usually identified by a rusty-brown to grayish-tan, powdery deposit and minor electrode erosion, indicating proper ignition and combustion conditions.

Normal conditions (fig. 5 right) where highly leaded gasolines have been used are usually identified by white, powdery deposits. If the spark plugs are cleaned at regular intervals and normal service conditions are encountered, these deposits have little or no effect on plug performance. However, prolonged high-speed, high load operation will fuse these deposits to form a yellowish glaze. At high temperatures, this glaze may be conductive, resulting in spark plug "missing" or fouling.

The main object in cleaning plugs is to remove all of the carbon and lead deposits from the insulator, shell, and electrodes. This can be done on a sand blast cleaner. Do not prolong the use of the abrasive blast as it will wear the insulator and damage the plug. A thorough cleaning of spark plugs should always include removing carbon and other deposits from the threads with a stiff wire brush. These threads are the means of carrying the heat away from the plug. Any deposits will retard the heat flow from the plug to the cylinder head, causing spark plug overheating and pre-ignition.

The electrode construction is such that the cleaning process sometimes does not remove the deposits from all surfaces of the electrodes. Therefore, it is important to clean the electrode surface with a small file. Dress the electrodes to secure flat parallel surfaces on both the center and side electrode.

By removing the oxide coating on the surface and providing sharp edges on the electrodes, the voltage required to jump the gap is reduced, and spark plug performance is improved. A visual inspection will indicate when the plug has been properly cleaned. The insulator appearance should be white and the metal case clean.

After cleaning, examine the plug carefully for cracked or broken insulators, badly pitted electrodes, or other signs of failure. Replace as required.

(3) **ADJUSTMENT.** Set the spark plug gap (0.032-0.036 inch) by bending the ground electrode.

(4) **TESTING.** Set the gap, then test the plugs on an approved tester. Compare the sparking efficiency of the cleaned and re-gapped plug with a new plug. Replace the plug if it fails to meet requirements.

During this test, check the plug for pressure leakage at the insulator seal. Apply a coating of oil to the shoulder of the plug where the insulator projects through the shell, and to the top of the plug, where the center electrode and terminal project from the insulator. Place the plug under pressure, and if air bubbles appear, the plug is leaking and must be replaced. If the plug is satisfactory, wipe it clean.

(5) **INSTALLATION.** Clean the area around the spark plug port to insure proper seating of the plug. Install the plugs, then tighten each plug to 15-20 foot-pounds torque.

c. High Tension (Secondary) Wires.

The high tension wires include the wires connecting the distributor cap to the spark plugs and the wire connecting the center terminal of the distributor cap to the center terminal of the ignition coil.

At regular intervals, clean and inspect the wires for cracked insulation and loose terminals. Wires can be checked for open circuits or high resistance with a 6-volt test lamp. All high tension wires should carry the full 6 volts with no voltage drop. Repair or replace the wires as required.

NOTE: To remove the wires from the spark plugs, grasp the molded cap only. Do not pull on the wire, as this may separate the wire connection inside the cap or damage the weather seal.

(1) **REPLACEMENT—6-CYLINDER ENGINE.** A spark plug wire set for 6-cylinder engines is available for service. The 6-cylinder ignition wire installation is shown in fig. 6.

(a) **REMOVAL.** Disconnect the wires at the spark plugs and at the distributor cap. Remove the weather seals on the distributor end of the wires and the rubber

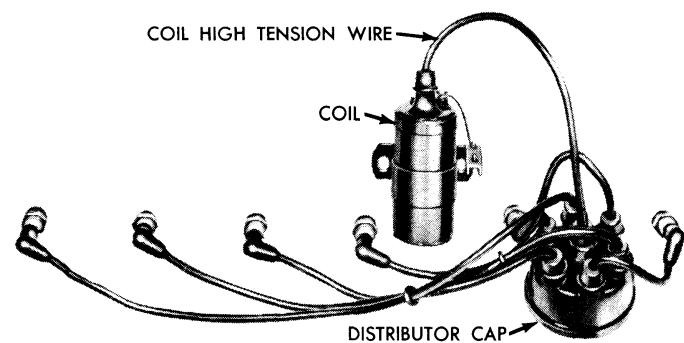

Fig. 6—Ignition Wire Installation—6-Cylinder Engine

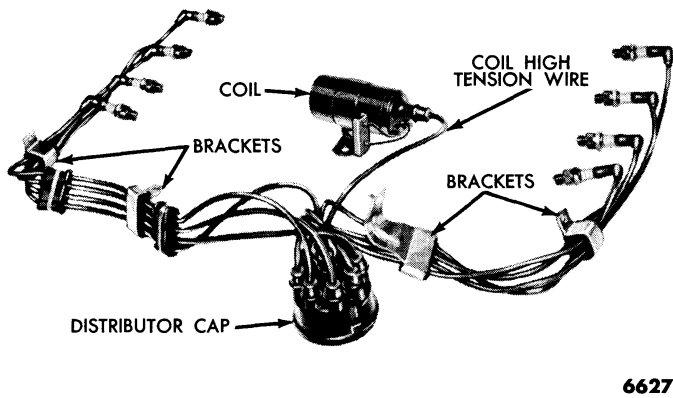

Fig. 7—Ignition Wire Installation—8-Cylinder Engine

rings. Disconnect the ignition coil to distributor high tension wire assembly from the coil and distributor cap.

(b) **INSTALLATION.** Install a rubber ring on the number 3 and 4, and on number 5 and 6 wires. Connect the wires to the proper spark plugs. Install the weather seals on the distributor end of the wires, and insert the ends of the wires in the correct sockets in the distributor cap. Be sure the wires are forced all the way down into their sockets and that they are held firmly in position. Each socket is identified on the cap. Install the wires in a clockwise direction in the firing order 1-5-3-6-2-4. Install the coil to distributor wire, and push all weather seals into position.

(2) **REPLACEMENT—8-CYLINDER ENGINE.** A spark plug wire set is available for service. The ignition wire installation is shown in fig. 7.

(a) **REMOVAL.** Remove the mounting brackets, disconnect the wires from the spark plugs and the distributor cap.

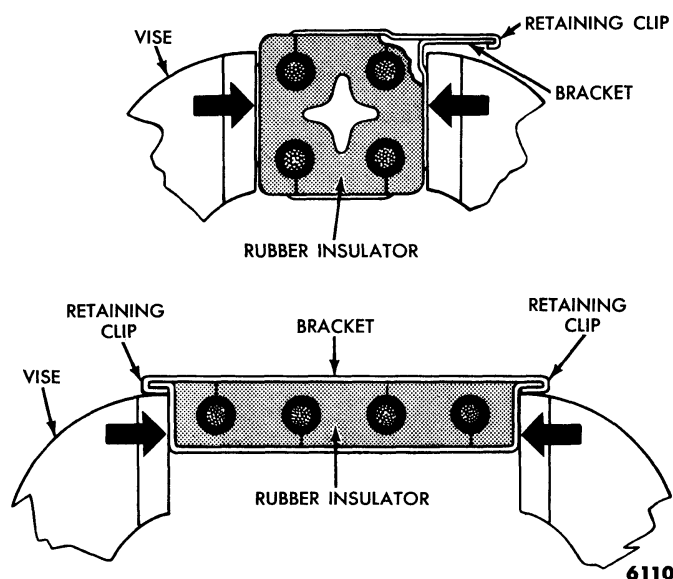

Fig. 8—Releasing Bracket Clips

Remove the high tension wires and brackets from the engine. To remove the old wires from the brackets, squeeze the brackets in a vise, applying force in the direction shown in fig. 8, to release the bracket clips. Pull the rubber insulator out of the bracket, and separate the wires and insulators.

(b) **INSTALLATION.** Install new wires in the rubber insulators. Be sure the wires are positioned correctly in the insulator and the insulator is in the correct location with relation to the bracket mounting points on the engine (fig. 7).

Position the insulators in the brackets, and squeeze the brackets in a vise to facilitate snapping the bracket tips under the retaining clips. Install weather seals on the distributor ends of the wires. Install the wires and brackets on the engine. Insert each wire in the proper distributor cap socket. Be sure the wires are forced all the way down into their sockets. The number one socket is identified by the number "1" on the cap. Install the wires in a counterclockwise direction in the firing order 1-5-4-8-6-3-7-2.

NOTE: Cylinders are numbered from front to rear—right bank, 1-2-3-4; left bank, 5-6-7-8.

Connect the wires to the proper spark plugs. Install the coil to distributor high tension lead, then push all weather seals into position.

d. Coil and Resistor.

The same coil and resistor are used on all engines. They are mounted on the cylinder head of the 6-cylinder engine, and right rear corner of the intake manifold of the 8-cylinder engine.

(1) **REMOVAL.** Disconnect the high tension lead and the primary leads from the coil. Remove the coil mounting screws and remove the coil. If necessary, disconnect the wires and remove the resistor.

(2) **INSTALLATION.** Place the coil and resistor in position and install the mounting screws. Insert the high tension lead into the coil socket, and connect the primary wires to the coil and resistor. Be sure the wires are properly installed as shown in fig. 1. Push the weather seal tightly against the coil.

(3) **TESTING ON CAR.** Remove one spark plug wire, and install a terminal adaptor in the wire terminal. Hold the end of the adaptor approximately $\frac{3}{16}$ -inch from the cylinder head. Run the engine at idle speed. The spark should jump the gap regularly.

(4) **TEST ON A COIL TEST UNIT.** Install the coil on a test unit and check the coil output, following the instructions of the test unit manufacturer.

e. Timing.

The 6-cylinder engine is equipped with a crankshaft damper having five timing marks (fig. 9). The long mark represents top dead center (T.D.C.) and each succeeding mark represents 3°, 5°, 7°, and 9°, respectively, before top dead center (B.T.D.C.). These marks, and a pointer welded to the cylinder front cover, are used to time the engine.

The 8-cylinder engine is equipped with a crankshaft damper having six timing marks (fig. 10). The long mark represents T.D.C. and each succeeding mark represents 2°, 4°, 6°, 8°, and 10°, respectively, B.T.D.C. These marks and a pointer, bolted to the water pump, are used to time the engine.

(1) **INITIAL TIMING.** The initial timing should be set as follows:

3° B.T.D.C.—All 6 and 8-cylinder cars with standard or overdrive transmission.

6° B.T.D.C.—All 6 or 8-cylinder cars with Fordomatic.

NOTE: *If the distributor has been removed from a 6-cylinder engine, be sure the oil pump intermediate shaft engages the seat in the oil pump. On 8-cylinder engines, make sure the distributor shaft engages the oil pump intermediate hex shaft. It may be necessary to turn over the engine with the starter, after the distributor drive gear is partially engaged, in order to engage the intermediate shaft.*

(2) **CHECKING TIMING WITH TIMING LIGHT.** Disconnect the distributor vacuum line.

Connect the timing light high tension lead to the number one spark plug and the other two leads of the timing light to the battery terminals. Clean the dirt from the timing marks, and if necessary, chalk the proper mark and the pointer to improve legibility. Operate the engine at idle speed. The timing light should flash just as the proper mark lines up with the pointer, indicating correct timing. The operator's eye should be in line with the center of the damper and the timing pointer.

If the proper timing mark and the pointer do not line up, rotate the distributor until the correct mark and the pointer are in line.

On 6-cylinder cars, timing is advanced by counterclockwise rotation of the distributor body, and retarded by clockwise rotation.

The timing on 8-cylinder cars is advanced by clockwise rotation of the distributor body, and retarded by counterclockwise rotation.

After the ignition timing has been properly set, connect the distributor vacuum line, then check the dis-

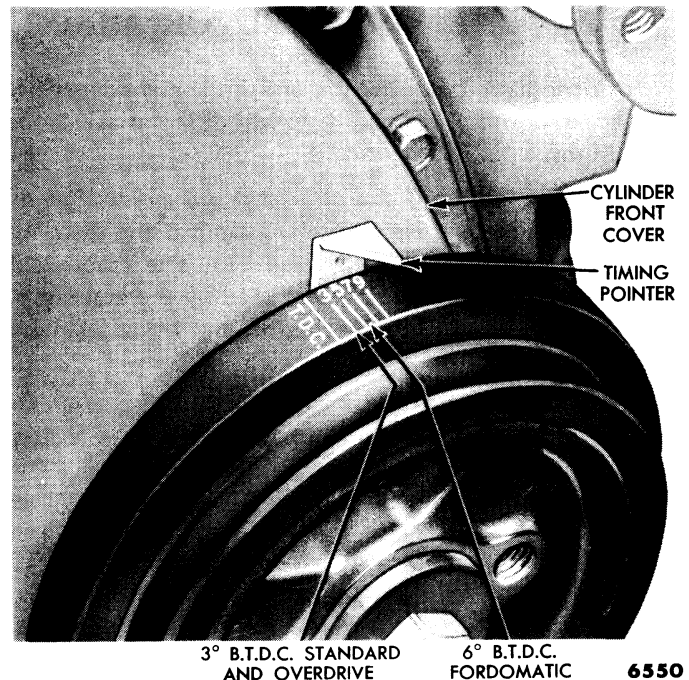

Fig. 9—Timing Marks—6-Cylinder

tributor to determine if the advance mechanism is operating. To do this, hold the timing light on the timing marks and pointer, and accelerate the engine. If no advance is evident, one of the following is the probable cause:

- (a) No vacuum available at the distributor.
- (b) Vacuum advance diaphragm leaking or disconnected from the breaker plate.
- (c) Breaker plate binding in the housing or on the bushing.

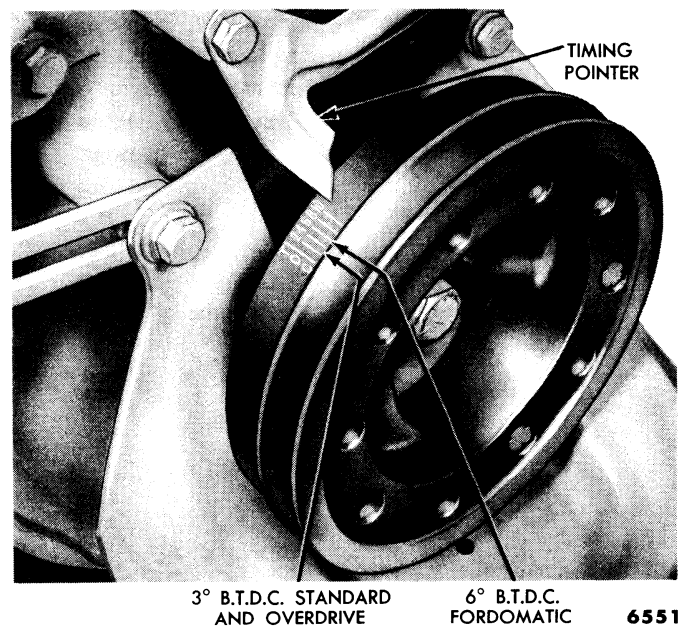

Fig. 10—Timing Marks—8-Cylinder

2. DISTRIBUTOR MINOR REPAIR AND ADJUSTMENTS

In loadomatic-type distributors the spark advance is regulated entirely by the vacuum differential at the carburetor.

The spark advance characteristics are controlled by two breaker plate springs, working against the distributor spark control diaphragm (fig. 11). The amount of spark advance obtained is determined by the amount of vacuum supplied to the distributor, and by adjustment of the breaker plate springs.

The 8-cylinder distributors, used with four barrel carburetors, incorporate a new double diaphragm for better control of breaker plate advance characteristics. The purpose of the second diaphragm is to provide a rapid spark retard at the acceleration tip-in point. The primary spark control diaphragm (closest to the distributor body) operates in the same manner as the single type diaphragm.

The 6-cylinder carburetor incorporates a nylon distributor vacuum passage check ball which, at high engine speeds, prevents venturi vacuum bleed back into the manifold and assures maximum spark advance.

A vacuum operated spark control valve is attached to the carburetor throttle body on all 8-cylinder engines to control manifold vacuum to the distributor and regulate spark advance. This feature improves engine performance and increases overall fuel economy.

a. Operation of Distributor Double Diaphragm.

The secondary spark control diaphragm (fig. 12) forces a quick, momentary spark retard while the distributor vacuum line, carburetor vacuum passages, and primary spark control diaphragm are normalizing to the new pressure conditions which develop when the spark control valve closes the manifold vacuum passage in the carburetor. This provides the sudden retard necessary

to prevent "tip-in" detonation. As soon as the vacuum passage pressures normalize, the primary spark control diaphragm again resumes full control of advance characteristics.

The secondary spark control diaphragm (furthest from the distributor body) is not connected either to the breaker plate or the primary spark control diaphragm. There is merely an air chamber between the two diaphragms. The secondary spark control diaphragm is held in an outward position by straight intake manifold vacuum working against a calibrated spring. This spring is located under the hex head plug in the center of the secondary diaphragm housing. The manifold vacuum is taken from the base of the carburetor throttle body. When the throttle is opened suddenly for rapid acceleration, manifold vacuum drops quickly, and the spring loaded secondary spark control diaphragm moves toward the primary spark control diaphragm. The resulting air pressure between the two diaphragms pushes the primary spark control diaphragm inward, providing a quick spark retard. In this way "ping" or detonation at the tip-in point of acceleration is definitely reduced if not entirely eliminated.

b. Operation of Spark Control Valve.

The spark control valve retards distributor spark advance during acceleration at low speeds to prevent excessive "ping" (detonation). When the throttle is opened to a setting greater than that required to maintain existing engine speed, manifold vacuum drops sufficiently to permit the spark control valve to close, cutting off the manifold vacuum passage to the distributor, thereby providing the spark retard needed to prevent objectionable "ping." As engine speed approaches the throttle setting, manifold vacuum builds up sufficiently to open the spark control valve, permitting manifold vacuum to effect the advance of the spark timing to meet engine requirements.

Through use of the spark control valve, a distributor advance curve has been established to provide the best spark advance under road load conditions without incurring "ping" on acceleration.

A schematic drawing of the spark control valve and the related vacuum passages in the carburetor is shown in fig. 13. Operation is as follows:

The inner side of diaphragm "A" is subjected to manifold vacuum while the outer side is exposed to atmospheric pressure. Spring "C" is calibrated to allow valve operation at approximately 6.5 inches of mercury manifold vacuum. Since vacuum passage "D" is above the throttle plate closed position, the spark control valve is

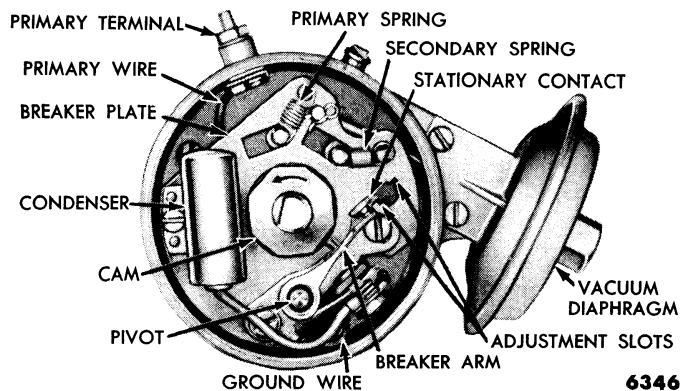

Fig. 11—Distributor—Typical

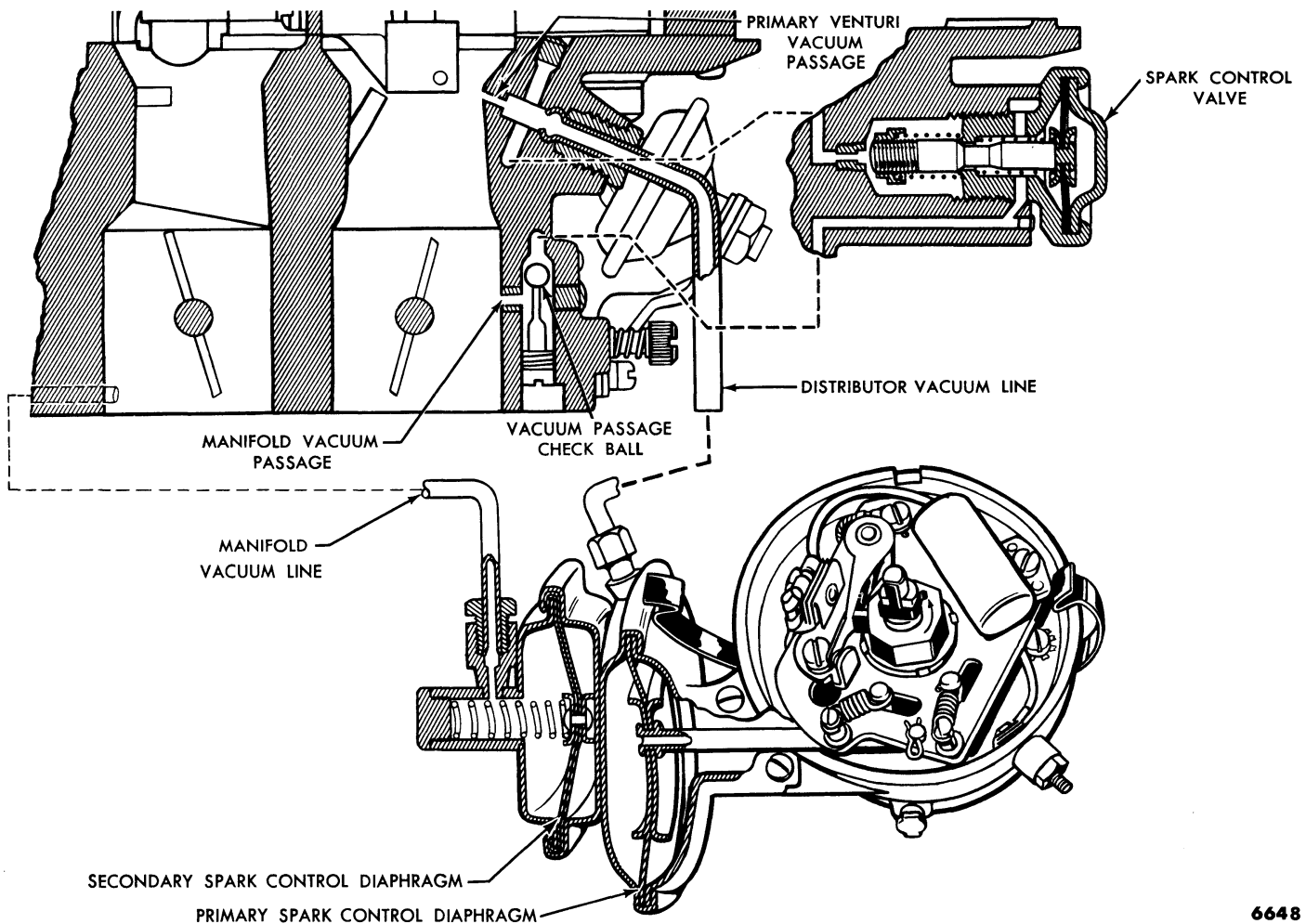

Fig. 12—Distributor Advance Controls

normally closed when the engine is not running or is only operating at idle speed.

When the vehicle is being operated at steady part throttle under normal road load conditions, manifold vacuum is above 6.5 inches of mercury and valve "B" is open, permitting manifold vacuum to effect distributor spark advance. Sudden opening of the throttle for acceleration causes a drop in manifold vacuum. When this drop reduces manifold vacuum below approximately 6.5 inches of mercury, the spark control valve closes, cutting off manifold vacuum to the distributor which results in a retard of spark timing. With the valve closed, spark advance is controlled entirely by venturi vacuum which is low at reduced engine speeds.

As engine speed approaches the throttle setting, manifold vacuum increases sufficiently to open valve "B" allowing manifold vacuum to again act on the distributor advance mechanism.

When operating the vehicle at high speeds, at or near full throttle opening, manifold vacuum is low and will

not hold the spark control valve open. Under these conditions, venturi vacuum is high and is the sole control of spark advance. With the spark control valve closed, venturi vacuum will not bleed back into the manifold, and the best possible spark advance is assured.

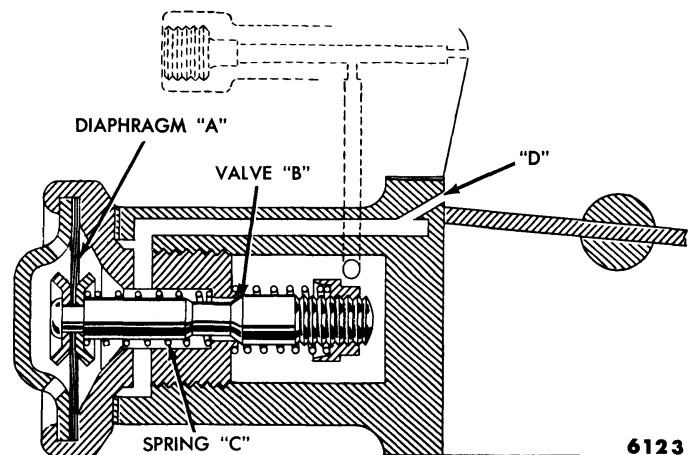

Fig. 13—Spark Control Valve Diagram

c. Distributor Points.

The distributor point assembly consists of the stationary distributor point bracket assembly, breaker arm, and primary wire terminal. The assembly is mounted on the breaker plate, as a unit, and can be replaced without removing the distributor from the engine (fig. 11).

Distributor points should be inspected, cleaned, and adjusted at regular intervals. Points can be cleaned with solvent and a stiff bristle brush. Replace the point assembly if the contacts are badly burned or excessive metal transfer between the points is evident. Metal transfer is considered excessive when it equals or exceeds the gap setting.

Burned points are generally the result of an accumulation of oil and dirt on the contacts. This is usually caused by oil bleeding from the distributor base bushing onto the points, by excessive or improper cam lubricant being thrown off onto the points, and/or neglect to clean the points periodically.

Excessive metal transfer between the points is generally caused by incorrect point alignment, voltage regulator setting that is incorrect, a radio condenser installed to the distributor side of the coil, an ignition

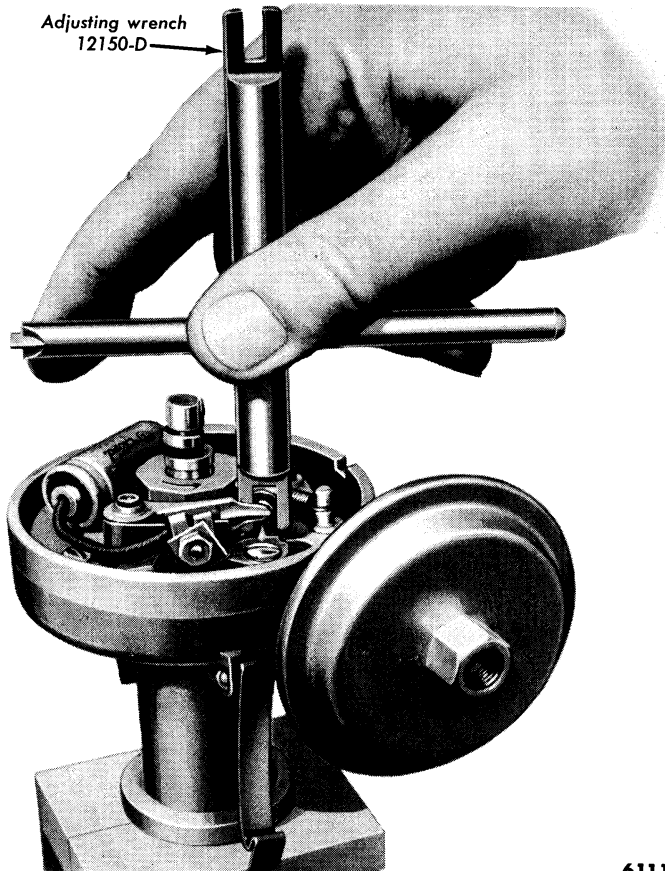

Fig. 14—Breaker Point Alignment—Typical

condenser of improper capacity, or extended operation at speeds other than normal.

(1) **REMOVAL.** Disconnect the primary and condenser leads. Remove the screws that secure the point assembly to the breaker plate, then remove the point assembly.

(2) **INSTALLATION.** Place the primary and condenser leads on the point assembly primary terminal. Install the lock washer and nut, then tighten the nut securely. Position the point assembly on the breaker plate, then install the hold down screws. Make sure the ground wire terminal is on the screw furthest from the adjustment slot. Adjust the distributor point gap.

(3) **SPRING TENSION.** Correct distributor point spring tension is essential to proper engine operation and normal point life. If the spring tension is too great, rapid wear of the breaker arm rubbing block will result, causing the point gap to close up and retard the spark timing. If the spring tension is too low, the breaker arm will flutter at high speed, resulting in an engine miss at high r.p.m.

To check spring tension, place the tension gauge as near as possible to the distributor points, then move the gauge at a right angle (90°) to the moveable arm until the points just open. If the tension is not within specifications (17-20 ounces), adjust the spring.

Disconnect the primary and condenser leads at the point assembly primary terminal. Loosen the nut holding the spring in position, then move the spring toward the breaker arm pivot to decrease tension and in the opposite direction to increase tension. Tighten the lock nut, then check spring tension. Repeat the adjustment until the specified spring tension is obtained. Install the primary and condenser leads with the lock washer and tighten the nut securely.

(4) **DISTRIBUTOR POINT GAP.** The distributor points can be adjusted with the distributor in the vehicle or on a test set. However, best accuracy and results will be obtained with the distributor removed from the engine.

The vented-type points must be accurately aligned and strike squarely in order to realize the full advantages provided by this design, and assure normal point life. Any misalignment of the point surfaces will cause premature wear, overheating, and pitting. Distributor points should be aligned by bending or twisting the fixed point only (fig. 14). Correct alignment and examples of misalignment are shown in fig. 15.

A light film of high-temperature, non-fibre grease should be applied to the cam when new points are installed.

CAUTION: Do not use engine oil to lubricate the distributor cam.

When distributor points are replaced or need adjustment, rotate the distributor cam until the rubbing block rests on the peak of a cam lobe. Loosen the lock screws, insert a screw driver, or the adjusting blade of the distributor adjusting wrench, in the adjusting slots (fig. 16), and turn it to obtain the proper point gap (0.024-0.026 inch on the 6-cylinder engine and 0.014-0.016 inch on all 8-cylinder engines). Tighten the lock screws and check the point gap. Check the dwell angle (35-38° on the 6-cylinder engine and 26-28½° on all 8-cylinder engines) with a dwell meter. Always reset the ignition timing after adjusting the distributor point gap.

d. Condenser.

The condenser can be removed from the distributor when the distributor is in the engine or when it is removed from the engine.

(1) **REMOVAL.** Disconnect the condenser lead from the distributor point primary terminal, and remove the screw that holds the condenser on the breaker plate. Lift the condenser out of the distributor.

(2) **INSTALLATION.** Position the condenser on the breaker plate. Install the condenser holding screw. Connect the condenser lead to the primary terminal.

(3) **TESTING.** Before removing the condenser to make a test, it is advisable to first make the test on the vehicle.

(a) **TEST ON VEHICLE.** This test is made at the same time and in the same manner as the coil test. If the spark is not satisfactory, it will be necessary to remove the condenser and test it on a test unit.

(b) **TEST ON TEST UNIT.** Install the condenser on a test unit, following the instructions of the test unit manufacturer. Test for leakage, series resistance, and capacity. Capacity is 0.21-0.25 microfarads, leakage should be greater than 5 megohms at room temperature, and series resistance should be 1 ohm or less.

e. Distributor.

The distributor should be removed from the engine when the vacuum advance is to be adjusted.

(1) **REMOVAL.** Before removing the distributor from an engine which is timed correctly, scribe a mark on the distributor body indicating the position of the rotor, and place another mark on the cylinder block and distributor body to indicate the position of the body. The distributor can be reinstalled and proper ignition timing retained using these marks as guides.

The distributor vacuum chamber diaphragm should be checked for leakage before making further tests. Hold the thumb over the end of a vacuum pump hose, then set the pump gauge to read 20 inches of Mercury. Attach the hose to the distributor diaphragm fitting (pri-

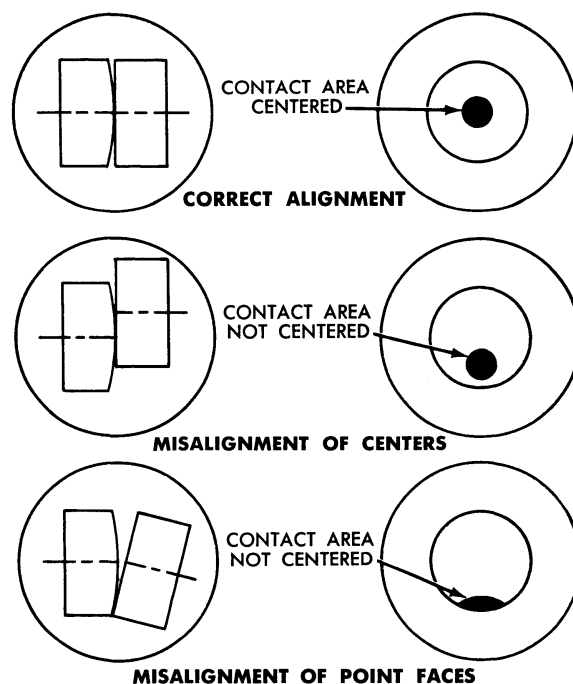

Fig. 15—Distributor Point Alignment

mary diaphragm fitting on double diaphragm unit). If the reading builds up to 20 inches of Mercury, the diaphragm(s) is in good condition. If the reading is less than 20 inches of Mercury, it indicates a leak in the diaphragm(s), and the diaphragm assembly should be replaced.

Remove the distributor.

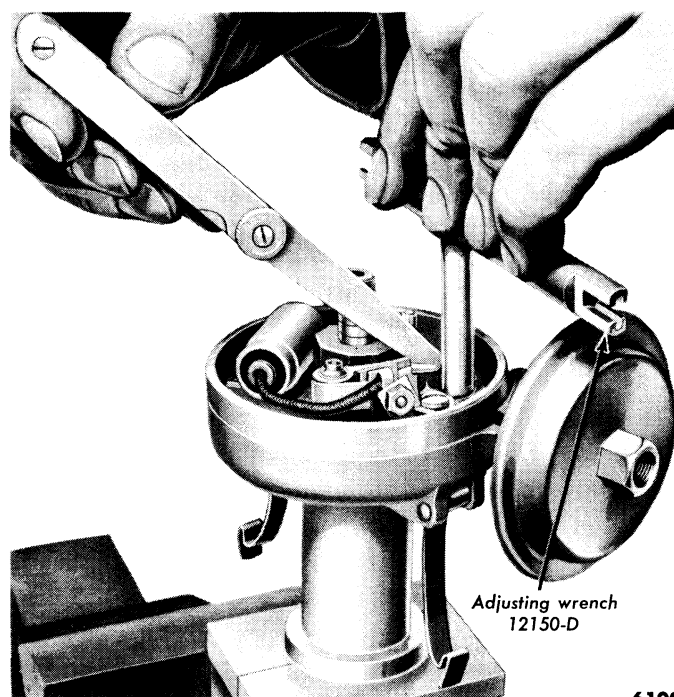

Fig. 16—Point Gap Adjustment—Typical

1299

6109

(2) **CHECK VACUUM ADVANCE.** Install the distributor on a distributor tester. Connect the dwell lead and check the dwell angle. If the dwell is not between 35-38° for the 6-cylinder engine distributor, or 26-28½° for all 8-cylinder engine distributors, and the point gap is not within limits, adjust the points. Check the breaker arm spring tension (17-20 ounces), and adjust if necessary.

Set the distributor speed at 200 r.p.m., hold the breaker plate against the stop in full retard position, then line up the zero degree position on the scale. Tighten the distributor holding clamp. Check the distributor according to the speed and vacuum settings given in the specification section.

Set the distributor speed to the proper r.p.m. and apply the required vacuum. Read the spark advance on the degree scale. If the spark advance is not within specifications, adjust the tension of the springs.

NOTE: *On double diaphragm units, connect the vacuum hose to the primary (closest to the distributor body) diaphragm fitting.*

(3) **VACUUM ADVANCE ADJUSTMENT.** If the above check does not prove satisfactory, release the tension on the two retard springs by turning both adjustment posts as required.

Using the adjusting wrench 12150-D or N, adjust the primary spring (farthest from the vacuum chamber)

first, for the low vacuum settings, and the secondary spring last, for the high vacuum settings.

The proper vacuum settings are given in the specifications section.

Check the operation of the vacuum advance according to specifications. If the spark advance is not within the limit under low vacuum, the primary spring adjustment is at fault. If the spark advance is not within the limits under high vacuum, the secondary spring adjustment is at fault.

If it is impossible to adjust both springs to give the correct spark advance throughout the range, one or both springs should be replaced and the spark advance readjusted. If the advance characteristics still cannot be brought within specifications, check to make sure the proper diaphragm assembly is installed.

(4) **INSTALLATION.** Align the rotor with the mark previously scribed on the distributor body. Install the distributor in the engine, with the marks previously made on the body and cylinder block in alignment. Check and adjust the ignition timing, using a timing light.

CAUTION: *When installing the distributor on a 6-cylinder engine, be sure the oil pump intermediate shaft engages the seat in the oil pump. On 8-cylinder engines, be sure the distributor shaft engages the oil pump intermediate hex shaft. It may be necessary to turn over the engine with the starter, after the distributor drive gear is partially engaged, in order to engage the intermediate shaft.*

3. DISTRIBUTOR OVERHAUL

Before overhauling the distributor it is advisable to test it on a distributor test unit for variation of advance characteristics. The test will give valuable information on distributor condition, and indicate the parts which need replacement.

a. Distributor—6-Cylinder Engine.

The distributor is mounted on the right side of the engine and is retained by two screws and lock washers.

(1) **REMOVAL.** Disconnect the primary wire at the distributor. Disconnect the distributor vacuum advance line, and remove the distributor cap. Scribe a mark on the distributor body indicating the position of the rotor, and scribe another mark on the body and engine block, indicating the position of the body in the block. These marks can be used as guides when installing the distributor in a correctly timed engine. Remove the screws and lock washers and pull the distributor out of the block.

NOTE: *Do not crank the engine while the distributor is removed or the initial timing operation will have to be performed.*

(2) **DISASSEMBLY.** If the vacuum unit, ground wire, insulator, and primary wire are in satisfactory condition, it is not necessary to remove these parts from the distributor body. Figure 17 illustrates the distributor parts in their relative positions.

(a) **SHAFT AND CAM REMOVAL.** Remove the pin that retains the oil pump drive shaft in the distributor shaft, then remove the oil pump drive shaft. If necessary, file the peened end from the pin retaining the distributor drive gear. Drive out the pin with a punch as shown in fig. 18. Remove the drive gear. If the gear does not remove easily by hand, press it off the shaft as shown in fig. 19. Slide the distributor shaft out of the body.

(b) **BREAKER PLATE REMOVAL.** Place the distributor body in a holding block, and clamp the block in a vise as shown in fig. 20. Remove the distributor point assembly.

bly. Remove the condenser. Remove the hair pin retainer, disconnect the vacuum advance rod, and push the rod out of the plate. Release the tension on the return springs, and disconnect the springs.

NOTE: *Do not stretch the springs as distortion may result, making it difficult to obtain adjustment.*

Remove the lock ring attaching the breaker plate to the upper bushing. Lift the breaker plate from the body. If it is necessary to replace the primary wire or ground wire, remove them at this time.

(c) **INSPECTION.** Inspect the distributor shaft and bushings for wear. The minimum allowable shaft diameter at the bushing is 0.4675 inch. The maximum allowable inside diameter of the bushing is 0.4690 inch.

(d) **BUSHING REMOVAL.** Compress and insert the slotted end of the tool in the distributor body as shown in fig. 21. Allow it to expand and butt against the lower bushing. Drive out the bushing. Invert the body then drive out the upper bushing.

(3) **ASSEMBLY.** Be sure to oil the bushings and shaft before installation.

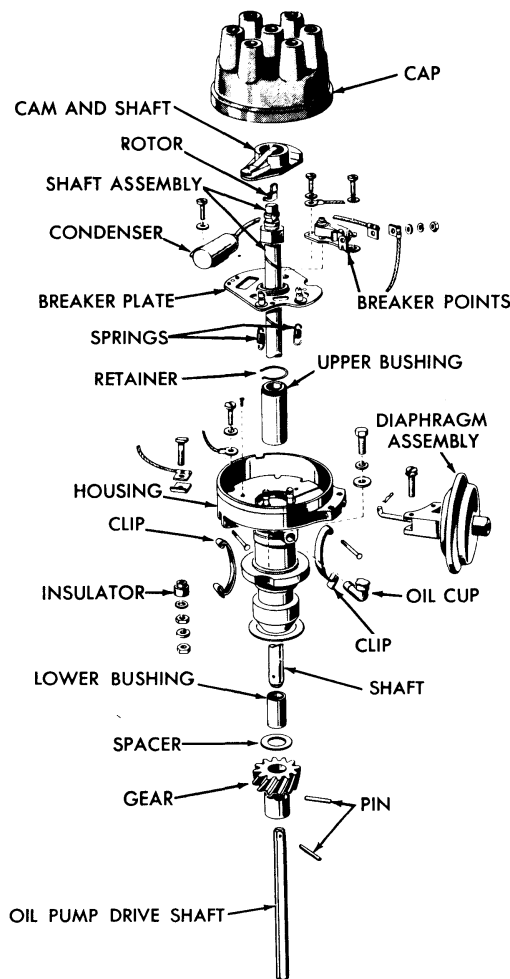
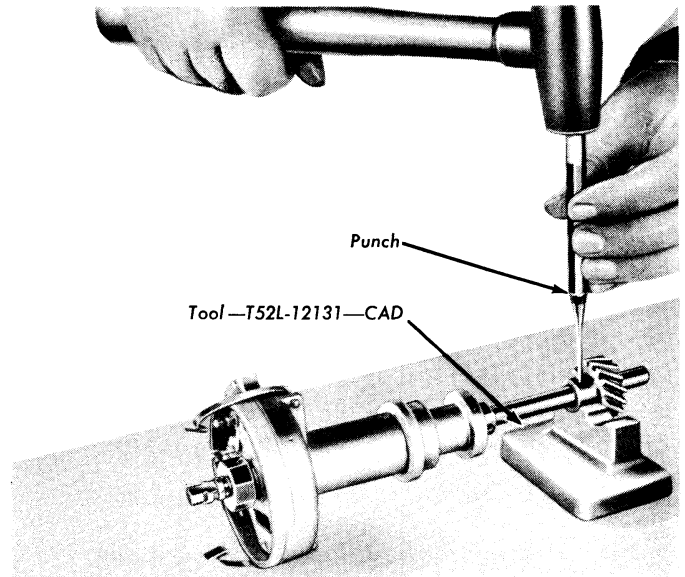

Fig. 17—Distributor—6-Cylinder Engine

6347



6285

Fig. 18—Gear Pin Removal—Typical

(a) **BUSHING INSTALLATION.** Position a new lower bushing on the bushing installation tool, then install the bushing in the distributor body as shown in fig. 22. Turn the tee-handle on the tool until the lower bushing is flush with the distributor body. Position the upper bushing in the body with the lock ring end up. Install the bushing with the tool shown in fig. 23. Turn the tee-

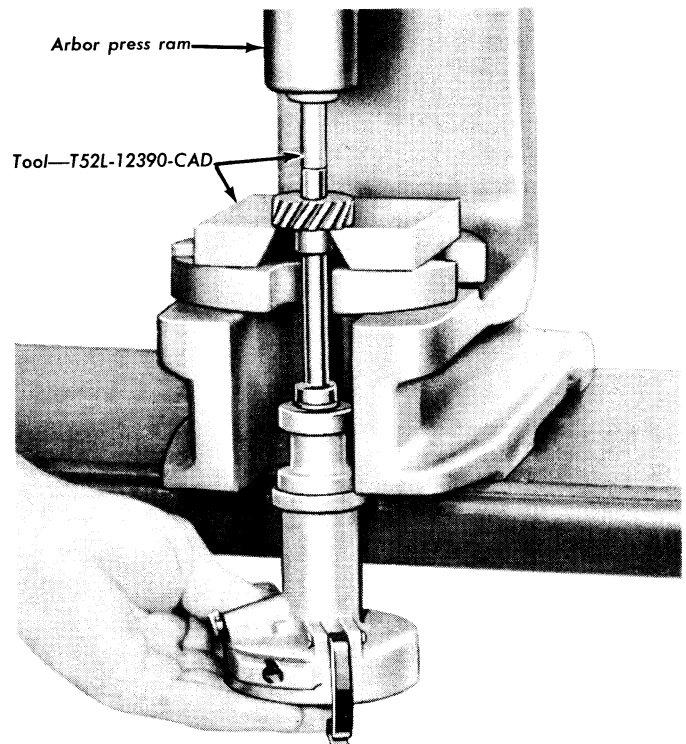

6300

Fig. 19—Gear Removal—Typical

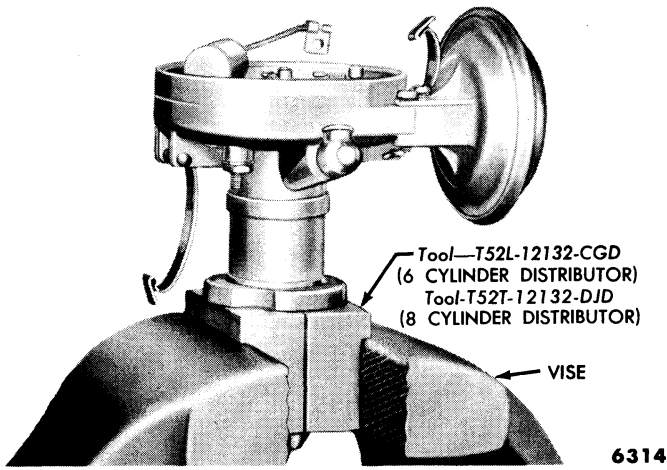

Fig. 20—Distributor Holding Fixture—Typical

handle on the tool until the adaptor bottoms firmly against the distributor body.

NOTE: Before using the tool shown in fig. 23, check the adapter that fits over the distributor shaft bushing. The base of the adapter must be chamfered to allow it to bottom against the distributor body. Tools which do not have this chamfer may be reworked by grinding a 60° chamfer on the outside diameter as shown in fig. 24.

Burnish both bushings to the proper size with a burnishing tool as shown in fig. 25.

(b) **BREAKER PLATE INSTALLATION.** Install a new ground wire and the primary wire in the distributor body if the original wires have been removed.

Position the breaker plate in the body. Install the lock ring to secure the plate. Install the condenser then place the condenser lead, primary lead, lock washer, and nut on the primary terminal. Install the distributor

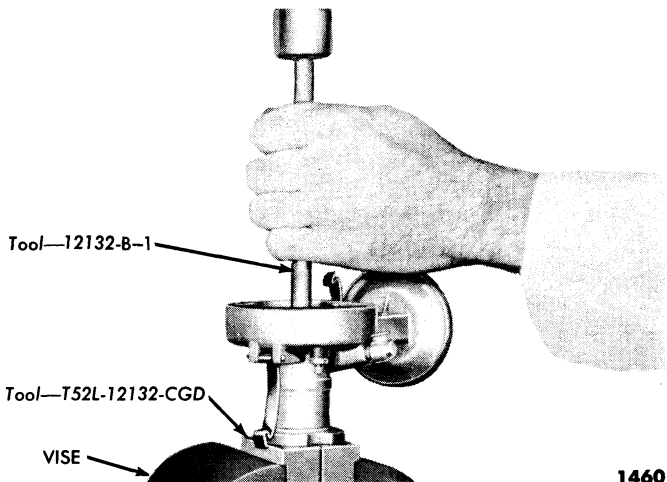

Fig. 21—Bushing Removal

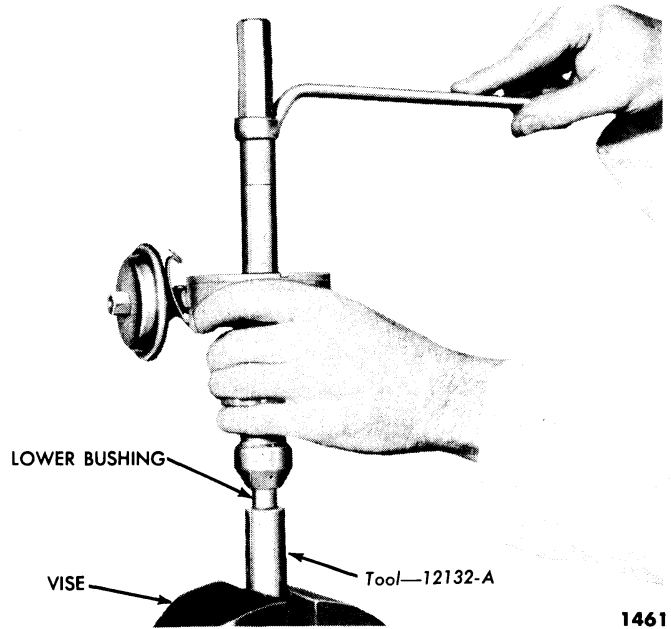

Fig. 22—Lower Bushing Installation

breaker point assembly. Be sure the pivot pin enters the hole in the breaker plate.

Install the ground wire and the screw at the adjustment slot end of the breaker assembly, and the screw and lock washer at the opposite end of the assembly. Install the vacuum unit on the distributor body if it has been removed. Install the two return springs on the adjustment and breaker plate posts. Insert the tip of the

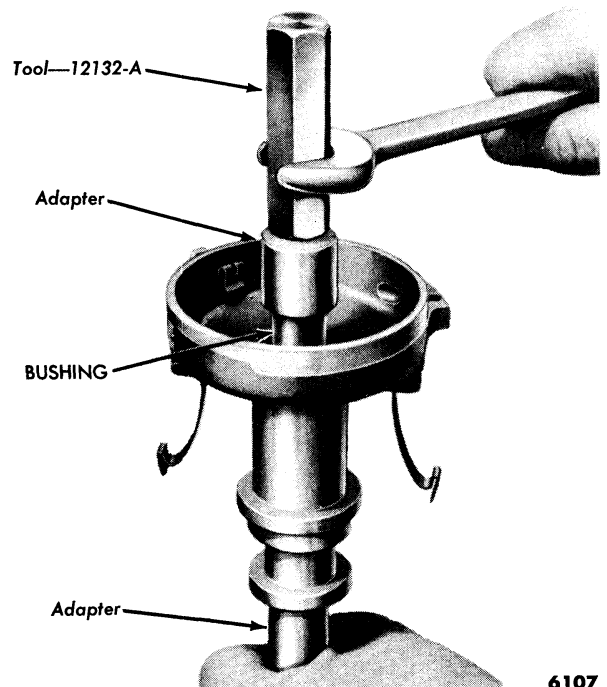

Fig. 23—Upper Bushing Installation—Typical

vacuum rod through the breaker plate, and attach the rod with the hair pin retainer.

CAUTION: *Make certain that the secondary spring is installed adjacent to the vacuum chamber.*

(c) **SHAFT INSTALLATION.** Slide the shaft into the body using care not to damage the rubbing block on the breaker points. Then place the spacer on the gear end of the shaft. Install the drive gear.

Press the gear on the shaft (fig. 26) until an end clearance of 0.005-0.008 inch is obtained. Drill the shaft with a No. 30 (0.1285) drill. Install the pin through the gear and shaft, andpeen the pin if the solid type pin is used, using the riveting fixture as a support.

Make complete adjustments, then insert the oil pump drive shaft in the end of the distributor shaft, and insert the retaining pin.

(d) **ADJUSTMENT.** Align the distributor points and lubricate the cam with high temperature, non-fiber grease. Adjust the spring tension and the point gap. Install the distributor on a distributor tester, check the dwell and point resistance, and adjust the vacuum advance.

(4) **INSTALLATION.** If the engine has not been turned over while the distributor was removed, install the distributor with the rotor aligned with the mark previously scribed on the distributor body, and the marks on the body and engine block in alignment.

If initial timing is required, set the engine crankshaft so that the number one cylinder is on T.D.C. after the compression stroke (with the timing mark in line with the pointer). Install the distributor so that the rotor points to the number one spark plug wire terminal in the distributor cap.

NOTE: *Make sure the oil pump intermediate drive shaft is properly seated in the oil pump. It may be necessary to turn over the engine with the starter*

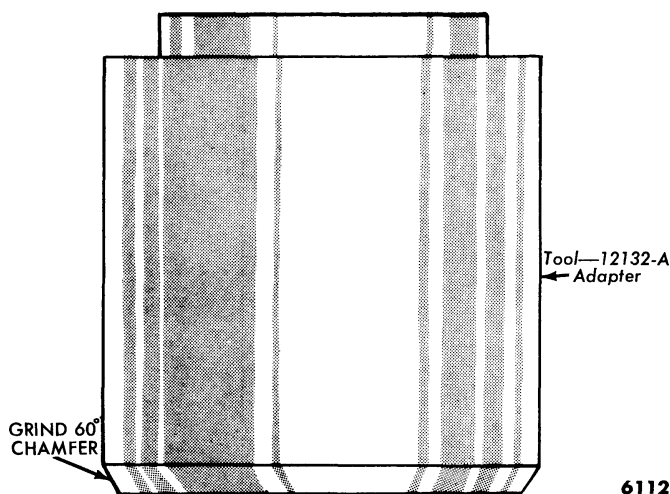

Fig. 24—Bushing Installer With 60° Chamfer

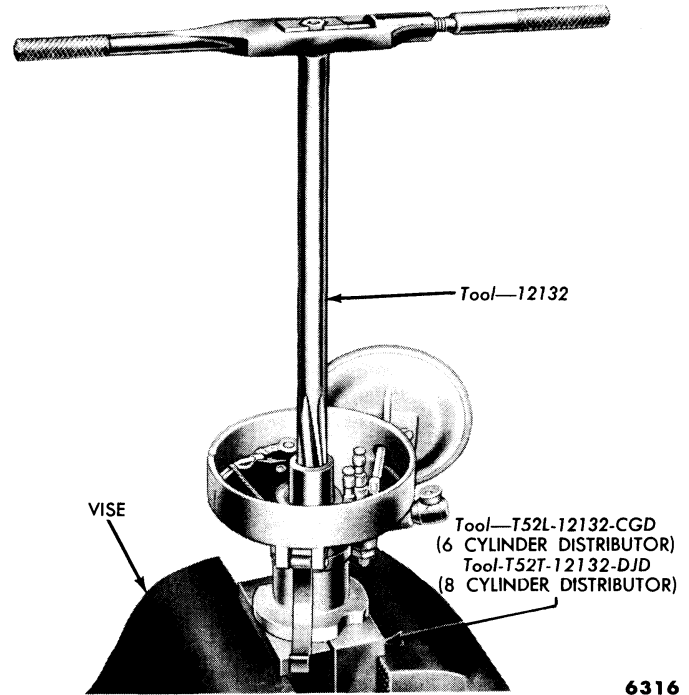

Fig. 25—Burnish Bushings—Typical

after the distributor drive gear is partially engaged, in order to engage the intermediate shaft fully in the oil pump.

Install the retaining screws and lock washers, but do not tighten the screws at this time. Connect the distributor primary wire. Rotate the distributor body clockwise until the points are just starting to open. Tighten the screws. Install the rotor and distributor cap. Start the engine, and check the initial timing with a timing light.

b. Distributor—8-Cylinder Engine.

The distributor is mounted at the rear of the cylinder block and is retained by a clamp and cap screw.

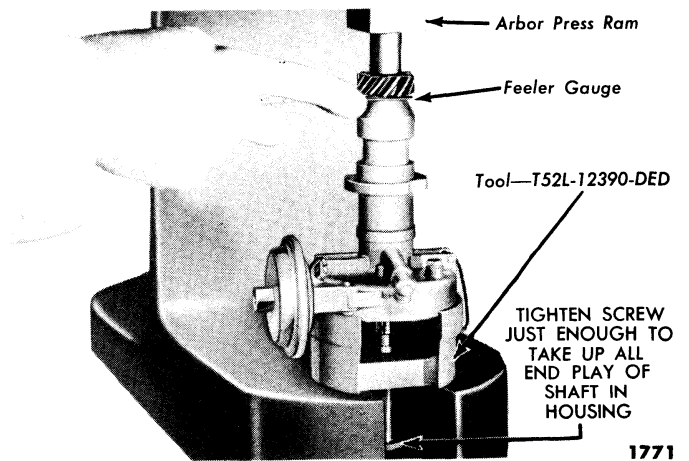

Fig. 26—Gear Installation

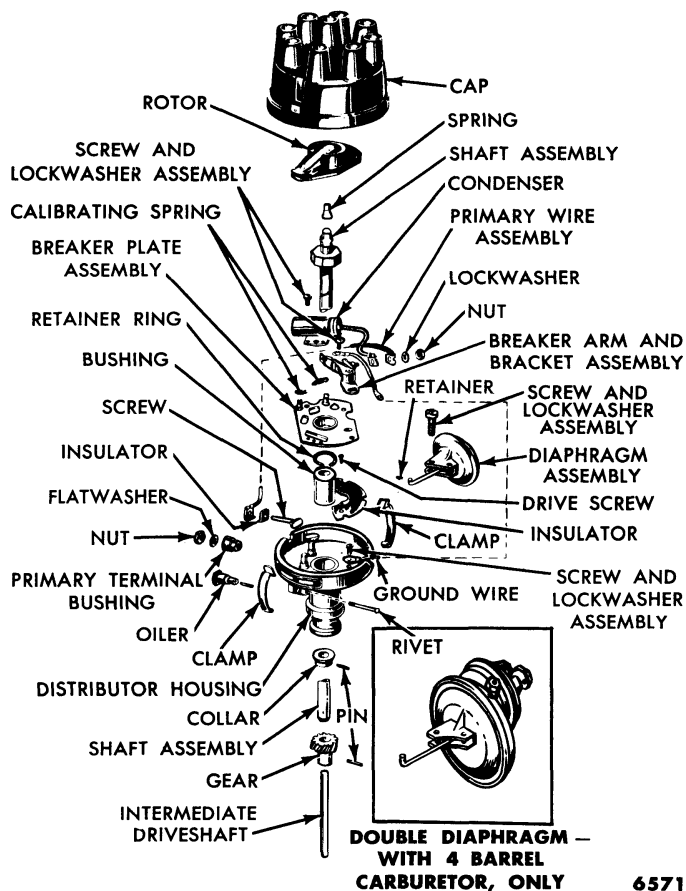
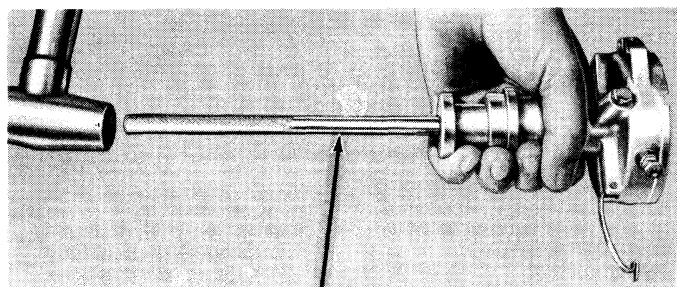

Fig. 27—Distributor—8-Cylinder Engine

(1) **REMOVAL.** Disconnect the primary wire at the distributor. Disconnect the distributor vacuum advance line, and remove the distributor cap. Scribe a mark on the distributor body indicating the position of the rotor, and scribe another mark on the body and engine block indicating the position of the body in the block. These marks can be used as guides when installing the distributor in a correctly timed engine. Remove the distributor hold down cap screw and clamp, then lift the distributor out of the block.

(2) **DISASSEMBLY.** If the vacuum unit, ground wire, and primary wire are in satisfactory condition, it is not necessary to remove these parts from the dis-



Tool—12132-B-1

6108

Fig. 28—Distributor Shaft Bushing Removal

tributor body. The distributor is shown disassembled in fig. 27.

(a) **SHAFT AND CAM REMOVAL.** File the peened end from the pin that retains the distributor gear on the shaft. Drive out the pin with a punch (fig. 18). If the gear does not remove easily by hand, press it off the shaft as shown in fig. 19.

If necessary, file the peened end from the pin that retains the collar. Drive out the pin with a punch using the same tool shown in fig. 18. Remove the collar from the shaft, then slide the shaft out of the distributor body.

(b) **BREAKER PLATE REMOVAL.** Place the distributor in a holding block, and clamp the block in a vise (fig. 20). Remove the distributor point assembly and the condenser. Remove the hair pin retainer, and push the vacuum advance rod out of the plate. Release the tension on the return springs and disconnect the springs.

NOTE: Do not stretch the springs as distortion may result, making it difficult to obtain adjustment.

Remove the lock ring attaching the breaker plate to the bushing, then lift the breaker plate from the body. If it is necessary to replace the primary wire or ground wire, remove them at this time.

(c) **INSPECTION.** Inspect the distributor shaft and bushing for wear. The minimum allowable shaft diameter at the bushing is 0.4675 inch. The maximum allowable inside diameter of the bushing is 0.4690 inch.

(d) **BUSHING REMOVAL.** Compress and insert the slotted end of the tool through the hole at the bottom of the body (fig. 28). Allow the tool to expand and butt against the bushing. Drive out the bushing.

(3) **ASSEMBLY.** Oil the shaft and bushing before installation.

(a) **BUSHING INSTALLATION.** Install a new bushing in the distributor housing as shown in fig. 23. When the adaptor bottoms against the housing, the bushing will be installed to the correct depth.

NOTE: Before installation of the bushing, check the adaptor which fits over the bushing. The base of the adaptor must be chamfered to allow it to bottom in the distributor body. Tools which do not have this chamfer may be reworked by grinding a 60° chamfer on the outside diameter as shown in fig. 24.

Burnish the distributor shaft bushing to the proper size with the distributor bushing burnishing tool (fig. 25).

(b) **BREAKER PLATE INSTALLATION.** Install a new ground wire and primary wire in the distributor body if the original wires have been removed. Position the

breaker plate in the body, and install the lock ring on the bushing to secure the plate. Install the condenser, then place the condenser lead, primary lead, lock washer, and nut on the breaker point terminal. Install the breaker point assembly, placing the ground wire terminal under the screw adjacent to the pivot. Install the vacuum unit on the distributor housing if it has been removed. Install the two return springs carefully so as not to overstretch them. Make certain that the secondary spring is installed adjacent to the vacuum chamber. Insert the tip of the vacuum rod through the breaker plate, and install the hair pin retainer in the end of the rod.

(c) **SHAFT AND CAM INSTALLATION.** Slide the shaft into the body, using care not to damage the rubbing block on the breaker points. Place the collar in position on the shaft and install a new pin. Check the shaft end play with a feeler gauge placed between the collar and body. If end play is not within limits (0.022-0.030 inch), the shaft must be replaced.

Install the distributor shaft supporting fixture (fig. 29), and tighten the backing screw sufficiently to remove all end play in the shaft.

Press the gear on the shaft as shown in fig. 29.

Install a new retaining pin, then check the gear location dimension. With all end play removed, this dimension should be 4.991-4.996 inches as measured from the bottom face of the gear to the bottom face of the distributor mounting pad. Use the gauge shown in fig. 29 to check this dimension.

If a new shaft must be installed, slide it into the housing, and attach the shaft supporting fixture (fig. 29). Using the holding fixture, clamp the assembly in a vise. Insert a 0.022-inch feeler gauge between the backing screw and the shaft as shown in fig. 30. Tighten the backing screw sufficiently to remove all shaft end play, then remove the feeler gauge, allowing the shaft to rest on the backing screw. Place the collar on the shaft, then while holding the collar against the distributor body, drill a $\frac{1}{8}$ -inch hole through the shaft using the hole in the collar as a pilot. Drill half way through from each side. Install the pin, then check the shaft end play to be sure it is between 0.022-0.030 inch. Peen the pin if the solid type pin is used.

Before installing the distributor gear, remove all shaft end play by tightening the backing screw.

Place the gear installing tool on the gear. Press the gear on the shaft to the proper dimension as measured by the gauge shown in fig. 29. Drill a $\frac{1}{8}$ -inch hole through the shaft using the pin hole in the gear shoulder as a pilot. Drill only half way through from each side. Install and peen the new pin, if the solid type pin is used.

(d) **ADJUSTMENT.** Align the distributor points, adjust the spring tension, and adjust the point gap. Install the

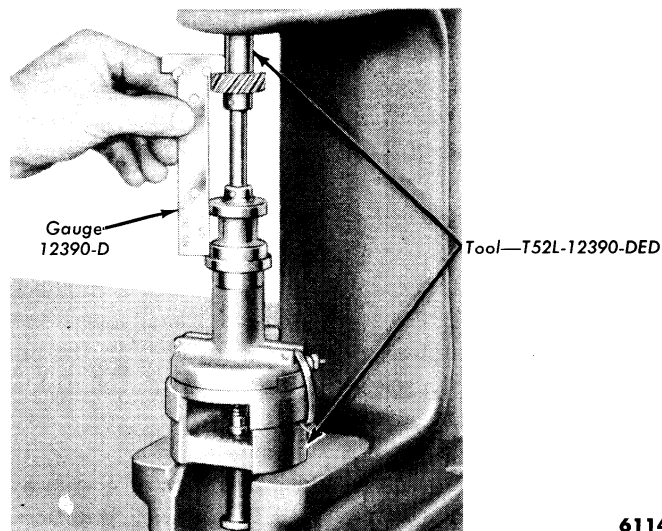

Fig. 29—Pressing Gear on Shaft

distributor on a test set, check the breaker point dwell and point resistance, and adjust the vacuum advance.

(4) **INSTALLATION.** If the crankshaft has not been disturbed, install the distributor using the marks previously scribed on the distributor body and engine block as guides. If the crankshaft has been rotated while the distributor was removed from the engine, it will be necessary to retime the engine. Crank the engine to bring number 1 cylinder to T.D.C. (after the compression stroke). Align the T.D.C. mark on the crankshaft damper with the timing pointer. Install the distributor so that the rotor points at the number 1 spark plug wire terminal in the cap.

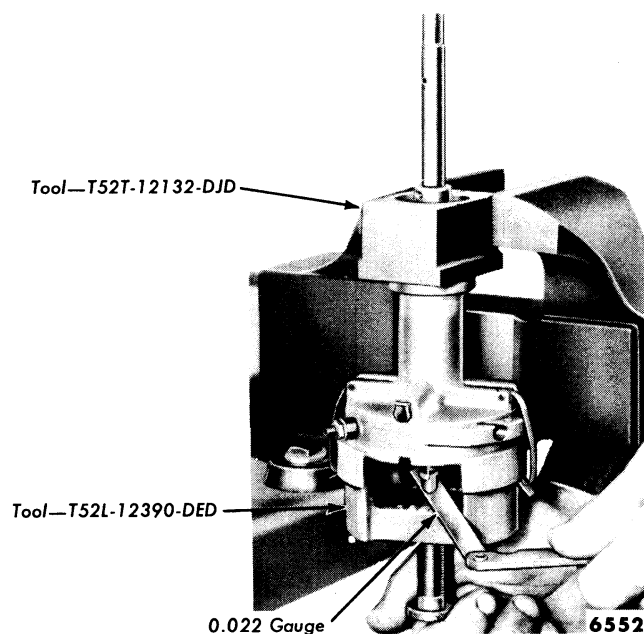

Fig. 30—Distributor Shaft End Play

NOTE: Make sure the oil pump intermediate shaft properly engages the distributor shaft. It may be necessary to turn over the engine with the starter, after the distributor drive gear is partially engaged, in order to engage the oil pump intermediate shaft.

c. Distributor Gear Backlash and Shaft End Play.

Certain circumstances will make it desirable to check the distributor gear backlash and the distributor shaft end play, upon installation of the distributor in the engine. This will only be necessary when the camshaft has been replaced, or a new distributor shaft, gear, body, or complete assembly has been installed.

The distributor gear backlash and shaft end play should be checked, when any of the above conditions exist, to avoid the possibility of damage to the distributor or camshaft when the engine is started. Improper end play or backlash will indicate one of the following:

- (a) Incorrect number of teeth on the distributor or camshaft gear.
- (b) Excessively worn gears.
- (c) Installation of incorrect part.
- (d) Improper installation of correct part or parts.
- (e) Foreign material obstructing the installation of

distributor.

After the distributor has been installed in the engine, check the distributor gear backlash with a dial indicator. Mount the indicator to take the reading at a point on the rotor approximately $\frac{5}{8}$ inch from the center of the rotor.

Mount the dial indicator in position to take the end play reading at the top of the shaft. Move the shaft up and down by grasping the shaft just above the cam.

NOTE: Be sure to use the "installed" specifications given in Table 1 when making these checks. Use the "removed" specifications when performing a distributor overhaul.

Before connecting the distributor vacuum line, check the initial timing with a timing light and adjust if necessary. Connect the vacuum line, and check the advance with the timing light when the engine is accelerated.

Table 1—Distributor Gear Backlash and Shaft End Play

ENGINE	End Play Dist. Removed (inch)	End Play Dist. Installed (inch)	Backlash Dist. Installed (inch)
6-cylinder	0.005-0.008	0.005-0.008	0.003-0.005
8-cylinder	0.022-0.030	0.004-0.020	0.003-0.007

4. CARBURETOR OPERATION AND ADJUSTMENTS — SINGLE AND DUAL CARBURETORS

Operating principles, tests, and adjustments pertaining to the single and dual carburetors are covered in this section under appropriate headings. Single-barrel carburetors are used on all 6-cylinder engines. Dual carburetors are standard equipment on 8-cylinder engines.

single and dual carburetors, each carburetor has four fuel circuits and the principles involved are the same for each. Minor variations in design are pointed out in the text.

Each system is designed to supply the correct quantity

a. Operation.

While some variation in design exists between the

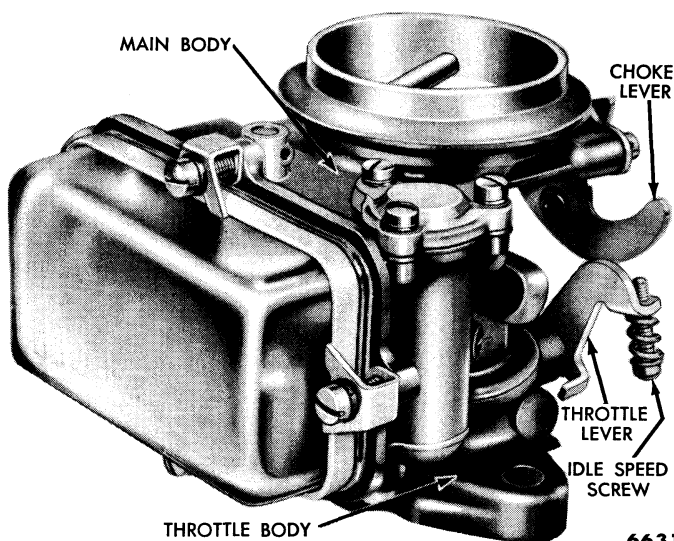

Fig. 31—Single-Barrel Carburetor

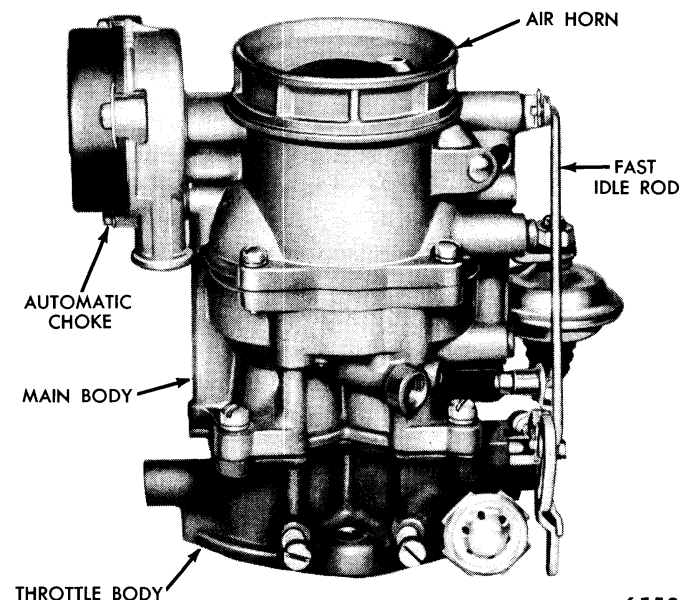

Fig. 32—Dual Carburetor

of fuel under a particular type of operation.

The carburetors are illustrated in figs. 31 and 32.

(1) **IDLE FUEL SYSTEM.** The fuel from the carburetor bowl passes through the main metering jet and into the idle tube, where air is introduced into the fuel stream by the idle air bleed. In the dual carburetor, the idle mixture goes around the booster venturi, then travels down the idle passages to the idle discharge holes.

In the single-barrel carburetor used on the 6-cylinder engine, the air and fuel travel down a passage under the air bleed and through the idle passages to the idle discharge holes.

When the engine is running at a speed of approximately 450 r.p.m., the mixture is discharged from the lower hole only, and the idle transfer holes act as additional air bleeds. As the throttle plate opens exposing the transfer holes to manifold vacuum, fuel begins to discharge from the transfer holes also.

The action and timing are such that the discharge from the transfer holes becomes less effective as the main nozzle starts to flow.

The lower discharge hole is provided with an idle adjusting screw. Turning this screw out gives a richer mixture and turning the screw in gives a leaner mixture.

(2) **MAIN FUEL SYSTEM.** The main fuel system starts to operate as the idle system becomes less effective and the main nozzle starts to deliver fuel. At this time there is a definite blend of the idle system and the main metering system.

In the dual carburetor, a supply of air is introduced to this mixture, by an air bleed in the side of the nozzle bar.

In the single-barrel carburetor, a supply of air is introduced into the main fuel well by the high speed air bleed. The fuel and air travel up the main well and are then discharged into the booster venturi where the fuel vaporizes and mixes with the air flowing through the carburetor

(3) **POWER FUEL SYSTEM.** The power fuel system vacuum diaphragm and spring are actuated by the vacuum below the throttle plate. At idle speed, vacuum is high but decreases as the load increases.

On the dual carburetor, the diaphragm actuated by the vacuum holds the power valve on its seat until the vacuum drops to about 7.5-9.0 inches of mercury, which is not high enough to resist the action of the spring.

On the single-barrel carburetor, the diaphragm and the spring are held in the "up" position which allows the valve to remain closed until the vacuum drops to approximately 6.0-7.0 inches of mercury.

Under load, as in climbing hills, the vacuum drops because it becomes necessary to open the throttle wider in order to maintain speed. When the vacuum drops below 6.5 inches of mercury, the power valve is opened

by the spring on the dual carburetor, and held open by the rod on the single-barrel carburetor. Additional fuel then flows through the power valve, into the main well, and out the main discharge nozzle. This gives the additional fuel required for high speeds, for heavy loads, and for low speeds at full throttle.

(4) **ACCELERATING SYSTEM.** The accelerating pump is connected to the throttle linkage, and its function is to enrich the mixture temporarily for rapid acceleration. The fuel is drawn into the pump chamber, through the pump inlet passage and the pump inlet ball check valve, on the upward stroke of the pump piston (or diaphragm). When the throttle is opened, the piston (or diaphragm) is moved in its discharge stroke, thus closing the pump check valve and overcoming the weight of the pump discharge needle valve. The accelerating fuel then goes around this valve, and out the pump discharge nozzle(s).

A spring on the slotted pump piston stem allows the pump operating rod to overrun the pump piston when the throttle is opened suddenly. This overrun causes the pump piston to be subjected to the pressure of the spring, thereby giving a prolonged steady discharge of the accelerating fuel.

(5) **AUTOMATIC CHOKE SYSTEM.** An automatic choke is provided on all dual carburetors. When a cold engine is being started, much of the fuel discharged by the carburetor is unable to vaporize during its travel to the combustion chamber until sufficient heat is developed in the intake manifold to maintain a homogenous mixture for efficient combustion. Therefore, a much larger quantity of fuel must be supplied to compensate for this lack of vaporization when starting and running a cold engine.

The choke plate, located in the air horn, provides a high vacuum above, as well as below, the throttle plates when it is closed. With a vacuum above the throttle plates, fuel will flow from the main system as well as from the idle system, thus bringing about the extremely rich mixture necessary for cold engine operation.

The carburetor choke shaft is linked to a thermostatic choke control mechanism, mounted directly on the air horn.

The bi-metal thermostatic spring in the choke control mechanism will unwind when cold and wind up when warm. When the engine is cold, the thermostatic spring holds the choke plate in a closed position. Manifold vacuum, channeled through a passage in the carburetor and choke control mechanism, draws the choke vacuum piston downward, exerting an opening force on the choke plate. When the engine is started, manifold vacuum, acting directly on the piston located in the choke housing, and the flow of air acting on the offset choke plate, immediately moves it against the tension of the thermo-

static spring to a partially open position to prevent stalling. As the engine continues to run, manifold vacuum by-passing the choke vacuum piston, draws air through an air heater tube in the intake manifold heat chamber where the air is warmed by the engine heat. The warmed air then enters the choke housing and heats the bi-metal spring, causing it to wind up. The tension of the bi-metal spring gradually decreases as manifold temperature rises, allowing the applied vacuum on the choke piston to further open the choke plate. The air then flows through a passage and is exhausted into the intake manifold.

When the engine reaches its normal operating temperature, the bi-metal spring no longer exerts an opposing tension on the choke piston, allowing the piston to pull the choke plate to the full open position. In this position, the choke piston is at its lowest travel in the cylinder. Slots in the piston bore allow sufficient air to bleed past the piston and into the intake manifold, permitting a continual flow of warm air to pass through the thermostat housing. The bi-metal spring thus remains heated and the choke plate remains fully open until the engine is stopped and allowed to cool.

If the engine should reach the stall point during the warm-up period, manifold vacuum will drop considerably. The tension of the bi-metal spring then overcomes the lowered vacuum acting on the choke piston, and the choke plate will be moved toward the closed position, providing a richer mixture to help prevent engine stalling.

The automatic choke is provided with an adjustment to control its reaction to engine temperature. By loosening three screws that retain the plastic cover, it can be turned in a clockwise direction ("rich"), which will require a higher engine temperature to fully open the choke plate. Turning the cover in the opposite direction (counterclockwise) will cause the choke plate to fully open at a lower engine temperature. This is the lean direction as indicated by the arrows on the cover. Proper adjustment will be very close to the mid-position mark as indicated by the divisions on the housing.

The linkage between the choke shaft and the fast idle cam is designed so the choke plate will partially open when the accelerator pedal is depressed to the wide open

position of the throttle. This permits unloading of a flooded engine. The linkage also holds the fast idle cam to a fast idle position until the engine has warmed up.

b. Idle Fuel Mixture Adjustment.

The idle fuel mixture is controlled by the idle mixture adjustment screw(s) (single-barrel carburetor has only one screw). The adjusting screws are shown in figs. 33 or 34. Turn the screw(s) "in" to lean the mixture, and "out" to enrich the mixture. Make the initial mixture adjustment by turning the screw(s) "in" until they lightly touch the seat. Then back off the screw(s) 1 turn.

CAUTION: *Do not turn a screw against the seat tight enough to groove the point. If a screw is damaged, it must be replaced before proper mixture adjustment can be obtained.*

Run the engine for 20 minutes at fast idle speed to bring it to normal operating temperature. Make sure the fast idle cam is in the slow position.

Turn the mixture adjusting screw(s) in until the engine begins to run rough from the lean mixture. Turn the screw(s) out until the engine begins to "roll" from the rich mixture. Then turn the screw(s) in until the engine runs smoothly. Always favor a slightly rich mixture rather than a lean setting.

On 8-cylinder carburetors the needles should be turned about the same amount. Final setting may vary 1/2 turn difference between the screws.

It may be necessary to reset the idle speed stop screw after the correct idle mixture is obtained.

c. Idle Speed Adjustment.

A stop screw controls the engine idle speed (figs. 33 or 35). Run the engine until normal operating temperature has been reached and the fast idle cam is in the slow position. Turn the idle stop screw "in" to increase the engine speed and "out" to decrease the engine speed. Idle speed should be 475-500 r.p.m. on all standard and overdrive equipped cars.

On Fordomatic equipped vehicles, place the selector lever in the N (neutral) position, then run the engine

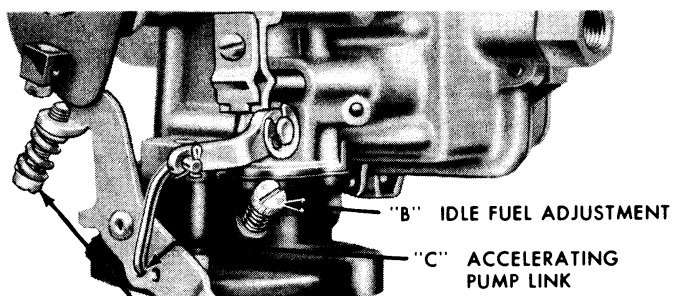

"A" IDLE SPEED ADJUSTMENT

3357

Fig. 33—Idle Adjustments—Single-Barrel Carburetor

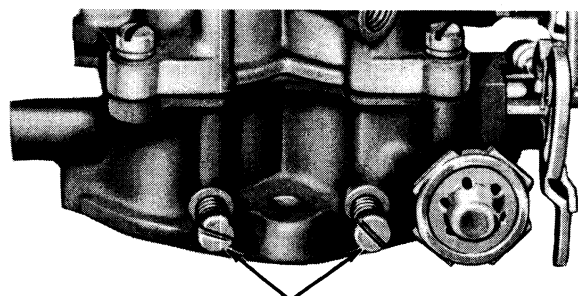

IDLE MIXTURE SCREWS

6554

Fig. 34—Idle Adjustments—Dual Carburetor

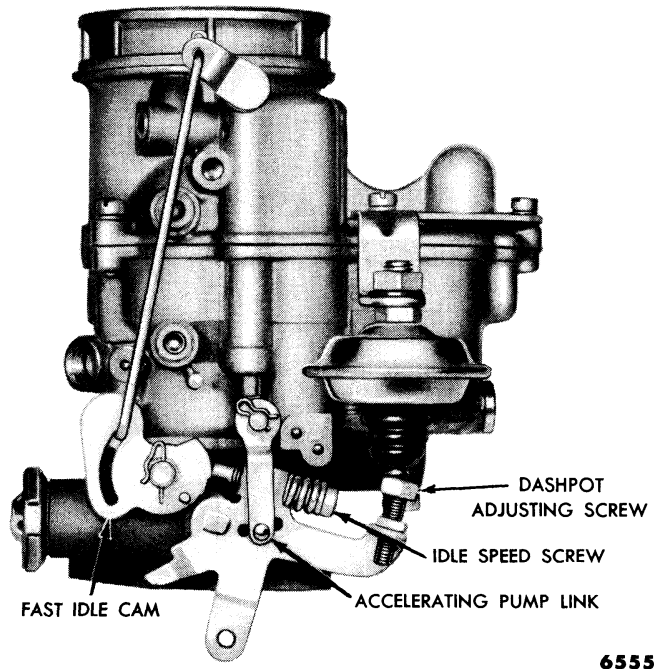

**Fig. 35—Idle Speed and Dashpot Adjustment—
Dual Carburetor**

until normal operating temperature is reached and the fast idle cam is in the slow position.

CAUTION: *Set the hand brake.*

Idle speed should be 475-500 r.p.m. Check the idle speed in DR (drive) position; it should be 425-450 r.p.m. If it is not 425-450 r.p.m. in DR (drive) range, adjust the idle speed so it falls in the DR (drive) range specification.

Adjust the anti-stall dashpot.

d. Anti-Stall Adjustment—Fordomatic Equipped Vehicles.

Adjust the engine idle speed.

Loosen the dashpot adjusting screw locknut (fig. 35).

Hold the throttle in the closed position, depress the dashpot plunger with a screwdriver blade. Turn the adjusting screw in a direction to provide the specified dashpot clearance of 0.045-0.064 inches.

Tighten the adjusting screw locknut to secure the adjustment.

e. Accelerating Pump Stroke Adjustment.

The quantity of fuel discharged by the accelerating pump is controlled by changing the position of the pump link in the throttle lever holes. On the dual carburetor, three positions are provided. The shortest stroke (closest hole to the throttle shaft) is suitable for hot weather operation. The center hole should be used for average conditions. The longest stroke, which provides the greatest fuel discharge, is recommended for extreme cold weather operation.

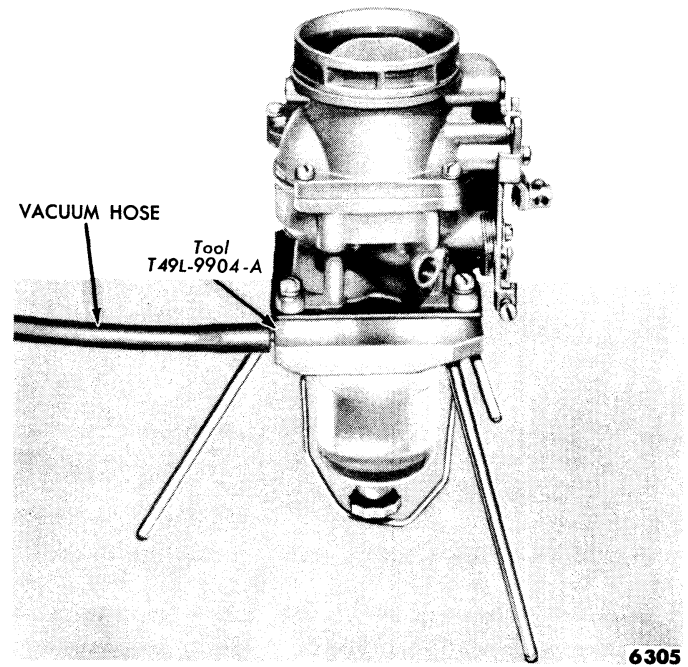

**Fig. 36—Carburetor Power Valve Diaphragm Check—
Typical**

The single-barrel carburetor has two positions. The inner hole is for average or hot weather operation, and the outer hole is for cold weather operation.

f. Checking Accelerating Pump.

Remove the air cleaner. Operate the throttle and observe the fuel flow from the discharge outlet. If the system is in good condition, a quick steady stream will flow from the outlet when the throttle is opened.

g. Checking Power Valve Diaphragm— Dual Carburetor.

Remove the carburetor throttle body. Position the carburetor main body in the fixture shown in fig. 36 with the power valve inserted into the counterbore of the fixture. Install the three throttle body screws to secure the main body to the fixture. Be sure the main body is seated and sealed securely to the neoprene pad. Remove the glass bowl from the fixture. Fill the bowl half-full of water. Install the bowl to the fixture. Connect a vacuum line from an idling engine (or a distributor test set) to the 1/4-inch tube on the fixture. Look for bubble formations from the end of the tube which is submerged in the water in the bowl. A continuous stream of bubbles indicates leakage through the power valve diaphragm or gasket. If leakage is encountered, the power valve gasket should be replaced with a nylon gasket. Repeat the check and if bubbles are seen, the power valve diaphragm is leaking, or the gasket seats are damaged and the defective parts should be replaced.

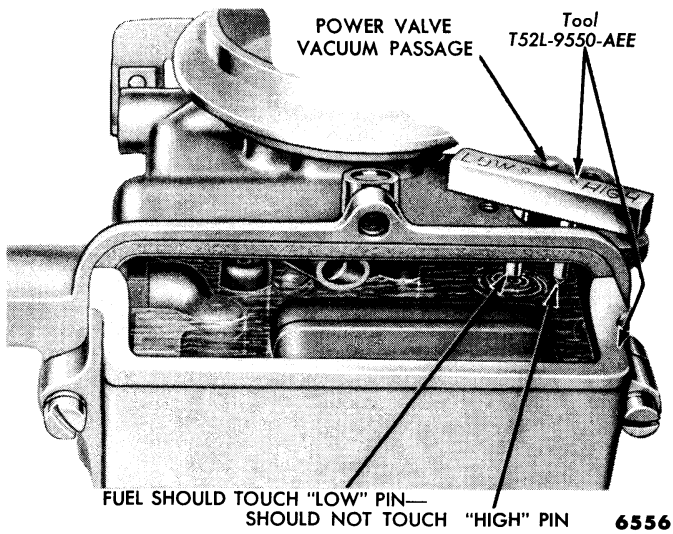

Fig. 37—Fuel Level Gauge—Single-Barrel Carburetor

A few bubbles may be noticed immediately upon attaching the vacuum line. The bubbling should stop within approximately 15 seconds or after the air has been removed from the system. If no bubbles are seen, the power valve diaphragm and gasket are sealing properly.

h. Checking and Adjusting Fuel Level.

Procedures for checking and adjusting the fuel level (or float level) are given below.

(1) **SINGLE BARREL CARBURETOR.** To check the fuel level, remove the power valve diaphragm cover and valve assembly. Place the fuel gauge in this opening. Hold a finger over the power valve vacuum passage, and start the engine. The fuel should touch the tip of the

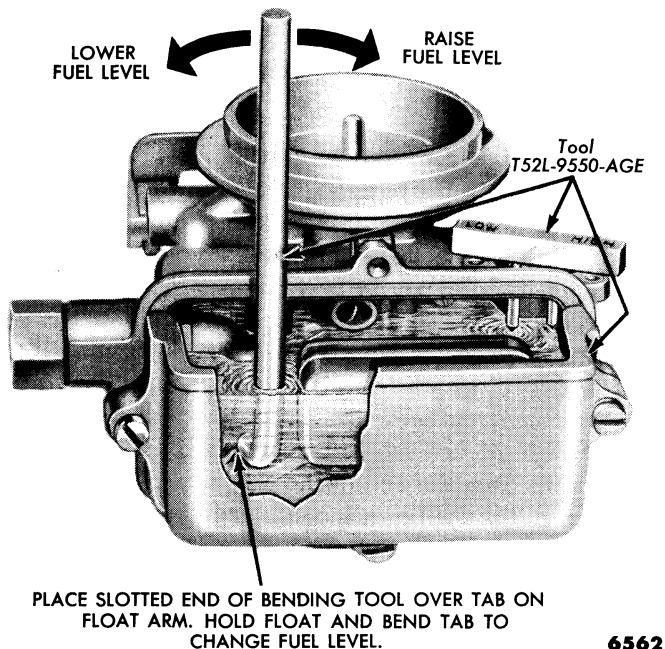

Fig. 38—Fuel Level Adjustment—Single-Barrel Carburetor

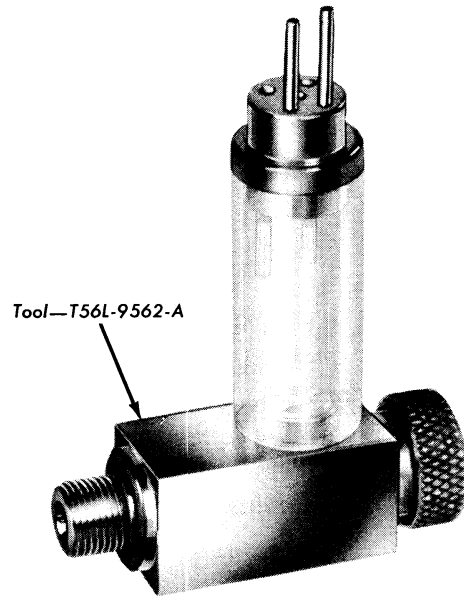

Fig. 39—Fuel Level Gauge—Dual Carburetor

“low” gauge pin and should not touch the tip of the “high” gauge pin.

If the fuel level is too high or too low, remove the carburetor fuel bowl, and install the dummy bowl using the fuel bowl gasket and three of the retaining screws (fig. 37).

CAUTION: *Position a suitable container under the carburetor to prevent fuel from splashing on the engine and manifolds.*

To adjust the fuel level, bend the float arm tab with the tool shown in fig. 38. Start the engine and recheck the fuel level.

(2) **DUAL CARBURETOR.** To check the fuel level, install the gauge shown in fig. 39 in one of the main jet plug holes. Operate the engine at idle speed. Proper fuel level is indicated by the “LO” pins in the gauge cap. If the fuel level is incorrect, remove the carburetor air horn and set the float level.

The float level is checked by holding the air horn upside down with the float in the closed position as shown in fig. 40. Check the dimension from the flange surface of the air horn to the edge of the soldered seam on the

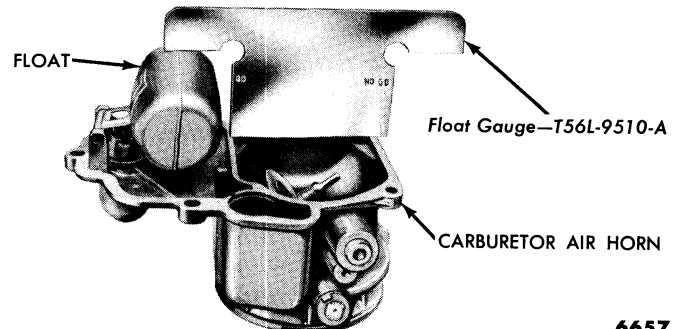

Fig. 40—Float Level Check—Dual Carburetor—Typical

bottom side of the float. The correct distance is 1.374-1.438 inches and it should be equal on both ends of the float. This dimension should provide the proper fuel level.

To correct the float setting, bend the float lever arm up or down until the float level is within the limits.

i. Automatic Choke Adjustment.

The automatic choke normally requires no attention under most operating conditions. Normal setting for the choke is alignment of the indexing mark on the cover with the center mark on the housing as shown in fig. 41. This setting should prove highly satisfactory for both winter and summer driving, as the thermostatic spring in the choke cover reacts to ambient air temperature as well as manifold temperature.

If hard starting is encountered while the engine is cold, and all other units are in standard operating condition, loosen the three choke cover screws and turn the cover in a clockwise direction, one notch at a time, until the engine starts properly. Turning the cover in a clockwise direction increases the spring tension on the choke lever, providing greater choking action.

If hard starting is encountered while the engine is hot, turn the choke cover in a counterclockwise direction, one notch at a time, until the engine starts properly. This

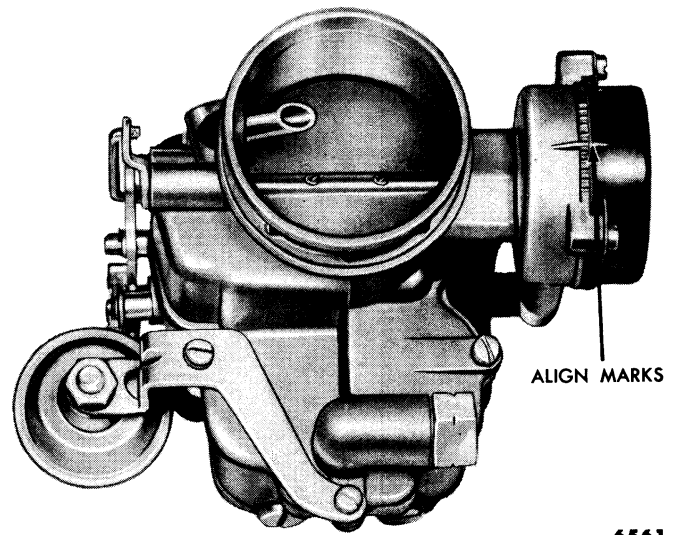

6561

Fig. 41—Automatic Choke Adjustment

is the “lean” direction as indicated by the arrows on the cover.

NOTE: *It should not be necessary to vary the choke setting more than two notches, in either direction, to obtain proper starting. If proper starting is not obtained within this range, refer to the “Trouble Shooting” Section for other possible causes.*

5. SINGLE BARREL CARBURETOR OVERHAUL

The carburetor is shown disassembled in fig. 42.

a. Removal.

Remove the air cleaner. Disconnect the accelerator rod, choke wire, fuel line, and distributor vacuum line. Remove the carburetor from the manifold.

b. Disassembly.

Use a separate container for the component parts of the sub-assemblies to facilitate cleaning, inspection, and assembly. The throttle plate and shaft should not be removed from the throttle body. The choke plate cannot be removed from the main body. If the choke plate or booster venturi is damaged, it will be necessary to replace the main body.

(1) **SEPARATE MAIN BODY FROM THROTTLE BODY.** Remove the accelerator pump link cotter pin and slide the upper end of the link out of the pump operating lever. Remove the two throttle body screws and lock washers. Separate the throttle body and main body, and remove the gasket.

(2) **DISASSEMBLE MAIN BODY.** Remove the fuel inlet fitting with a box wrench, and remove the gasket. Remove the dashpot if so equipped. Remove the four float bowl retainer screws, lock washers, and clamps.

Remove the retainer, retainer gasket, float bowl, and bowl gasket. Remove the fuel inlet seat screw and gasket located in the fuel inlet opening. Remove the fuel inlet needle valve and float assembly, and the gasket from inside the main body. Remove the float shaft, releasing the float. Slide the fuel inlet needle assembly off the float lever tab. Remove the wire clip, spring, and plunger from the fuel inlet needle. Remove the three power valve diaphragm screws and lock washers, then lift the power valve diaphragm and stem assembly out of the main body.

NOTE: *If the power valve diaphragm is known to be defective, separate the cover from the diaphragm and stem assembly, and discard the diaphragm and stem assembly.*

Remove the five main well and power valve body screws and lock washers, then remove the main well and power valve body. Remove the main jet with a jet wrench.

Remove the pump inlet check valve retainer and the pump discharge valve retainer from the main well body. Invert the body, allowing the pump inlet check ball, pump outlet check ball, and pump outlet weight to fall out into the hand. Remove the pump return spring from

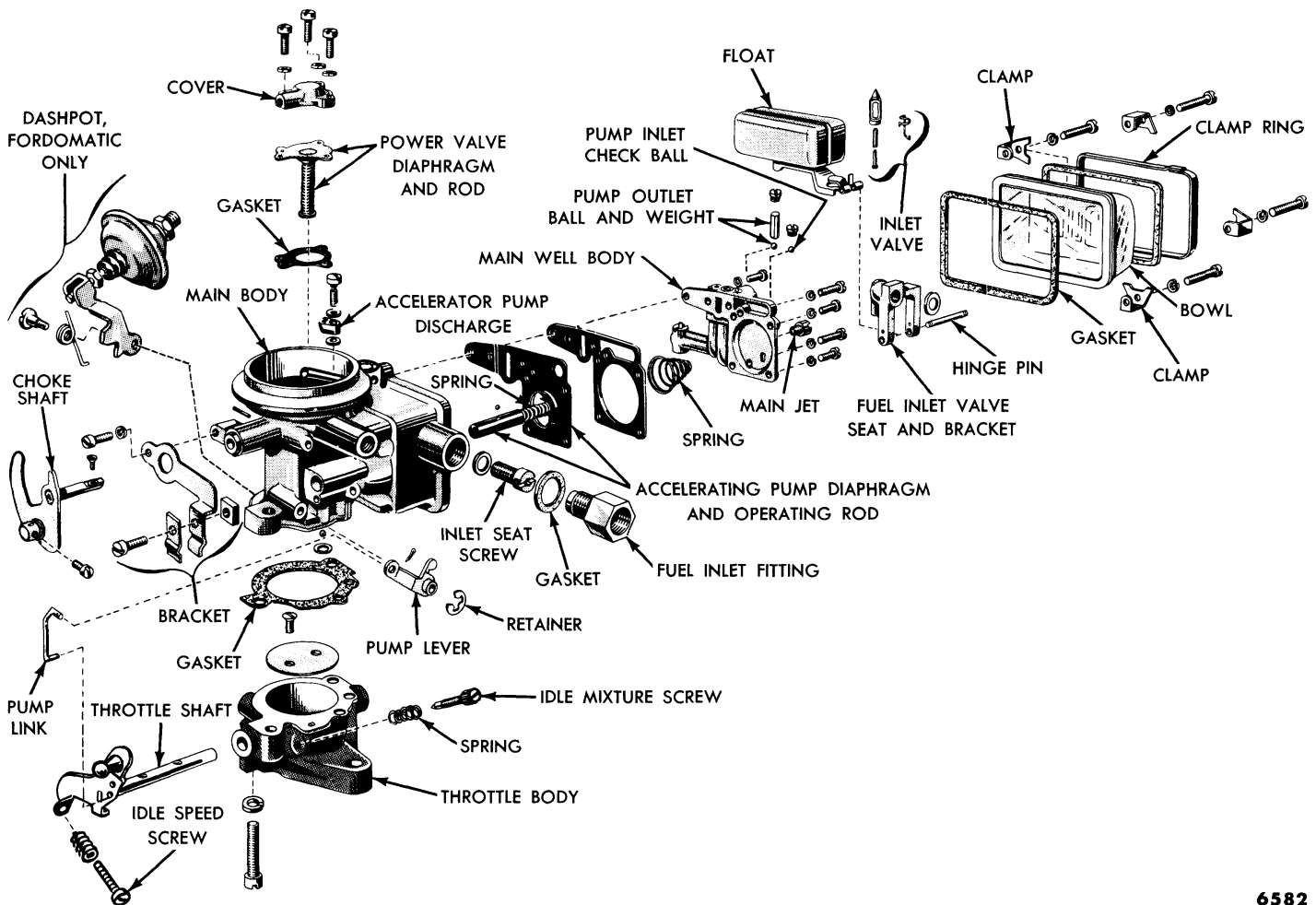

Fig. 42—Single Barrel Carburetor—Disassembled

6582

the metal disc on the accelerating pump diaphragm and rod assembly.

CAUTION: *Pull the accelerating pump diaphragm and rod assembly straight out of the main body to avoid damaging the diaphragm.*

Separate the gasket from the accelerating pump diaphragm.

Press the pump rod sleeve toward the diaphragm until the pump rod sleeve retainer ball drops out. Remove the pump rod sleeve. Pry the pump operating lever retainer off the stud. Remove the pump operating lever. Remove the pump discharge nozzle screw and pump discharge nozzle. Remove the distributor passage ball retainer and ball.

If it is necessary to remove the choke lever and shaft assembly, remove the screw retaining the choke plate to the shaft, and slide the shaft out of the main body.

NOTE: *The choke plate cannot be removed from the main body because the main discharge nozzle, which acts as one of the choke plate pivot points, is pressed in. If the choke plate or booster venturi is damaged, it will be necessary to replace the main body.*

(3) **DISASSEMBLE THROTTLE BODY.** Remove the idle adjusting needle and spring. Remove the pump link cotter pin and link.

At times it may be necessary to remove the throttle plate and shaft to accomplish a thorough cleaning job. If this is done, be sure to mark the throttle plate before removal so it can be reinstalled in exactly the same position. Throttle plates and shafts cannot be interchanged between carburetors, nor are they serviced as separate parts. This is done because the idle discharge hole is drilled after the throttle plate is installed, and is an individual operation for each throttle body assembly.

c. Cleaning and Inspection.

Many carburetor troubles are the result of deposits accumulating in the carburetor. A thorough cleaning must be performed to assure the satisfactory performance of the carburetor.

(1) **CLEANING.** Soak all castings and metal parts (except the dashpot) in a cleaning solution to soften and loosen all foreign deposits. If a commercial carburetor cleaning solvent is not available, lacquer thinner or denatured alcohol may be used. Remove all remain-

ing deposits with a stiff bristled brush. Blow out all passages in the casting with compressed air. Rinse the clean parts and castings in hot water to remove all traces of cleaning solution, then dry them with compressed air.

(2) **INSPECTION.** Replace the float if it leaks or if the assembly is damaged in any way. Replace the main body if the choke plate or booster venturi is damaged, or if the protective plating is damaged exposing bare metal to corrosion. Check the action of the poppet valve in the choke plate, and free it up if necessary. Replace the choke lever and shaft assembly if the threads in the shaft are stripped or if it is not securely riveted to the lever.

d. Assembly.

Always install new gaskets when rebuilding the carburetor. A carburetor overhaul kit is available for service.

(1) **ASSEMBLE THROTTLE BODY.** Install the pump link in the throttle lever, then secure it with a cotter pin. Install the idle adjusting needle and spring. Turn the needle in gently with the fingers until it seats, then back it off 1½ turns for a preliminary idle adjustment.

NOTE: Do not force the needle against its seat, to avoid grooving the tip of the needle.

(2) **ASSEMBLE MAIN BODY.** Install the distributor passage ball and ball retainer. Install a new gasket under the pump discharge nozzle, then insert the special nozzle screw through the grooved side of the nozzle. Install the nozzle in the recess at the top of the venturi in the main body. Tighten the pump discharge nozzle screw, keeping the nozzle centered in the recess. If it has been removed, position the choke bracket assembly on the protruding boss on the main body, and install the screw and washer. Slide the choke shaft and lever assembly into the main body, then install the screw through the shaft and choke plate, with the choke plate in the full closed position. Make sure the choke plate does not bind in the throat, then tighten the screw. Stake the choke plate screw.

Place the pump operating lever on the stud in the main body, and fit the pump operating lever retainer onto the stud. Place the spring on the pump diaphragm rod, and press the pump rod sleeve into the rod to compress the spring. Drop the pump rod sleeve retainer ball into the hole in the sleeve. Position the pump assembly in the main body fuel bowl, then place the main well body spacer gasket over the pump assembly. Install the pump inlet check ball and retainer in the main well body. Install the pump outlet check ball, the weight, and the retainer. Seat the check balls with one gentle tap of a light hammer on a soft brass drift, then

be sure the check balls move freely in their chambers before installing the retainers.

Install the main jet in the main well body with the jet wrench. Seat the large end of the pump return spring in the metal disc on the accelerating pump diaphragm. Position the main well body screws and lock washers in the body. The two long screws are placed in the center top and center bottom holes; the short screws are used in the three remaining holes. Insert the power valve end of the main well body into the main body, then press the main well body into position against the spacer gasket as follows:

Apply pressure with the index finger against the protruding end of the pump rod sleeve, to fully compress the pump return spring, as the thumb presses the main well body into position. This will prevent the pump return spring pressure from disturbing the alignment of the holes in the diaphragm, spacer gasket, and main body. Before releasing the pump rod sleeve, tighten the five main well body screws.

Position the power valve gasket, power valve diaphragm stem assembly, and the power valve body cover in the main body. Install the three power valve body cover screws and lock washers.

Place the inlet needle spring over the fuel inlet needle plunger, and insert these parts, spring first, into the hollow fuel inlet needle. Install the wire fuel valve clip on the fuel inlet needle. Clip the needle on the float lever tab. Guide the needle into the inlet needle seat, and position the float lever between the two float hinge bracket arms. Install the float lever shaft.

NOTE: Do not attempt to interchange fuel inlet needles or seats; they are matched assemblies.

Install the fuel inlet seat screw gasket on the screw, and insert the screw through the fuel inlet fitting boss in the main body. Place the seat gasket on the threaded end of the inlet seat screw which protrudes into the fuel bowl, set the float and fuel inlet valve assembly into position, and install the carburetor float gauge under the float hinge bracket as shown in fig. 43 to prevent the assembly from tilting when tightening the seat screw. Tighten the screw securely, then remove the gauge.

Invert the main body assembly, and check the setting of the float with the cardboard gauge provided in the repair kit (fig. 44). If necessary, bend the tab on the float arm to bring the float setting within limits. This should provide the proper fuel level.

Install a new float bowl gasket into the recess in the main body. Install the retainer gasket over the bowl. Place the retainer on the bowl, and set the bowl into position. Install the four clamps, screws, and lock washers. Tighten the two center screws, then the two end screws, alternately, to evenly compress the gasket

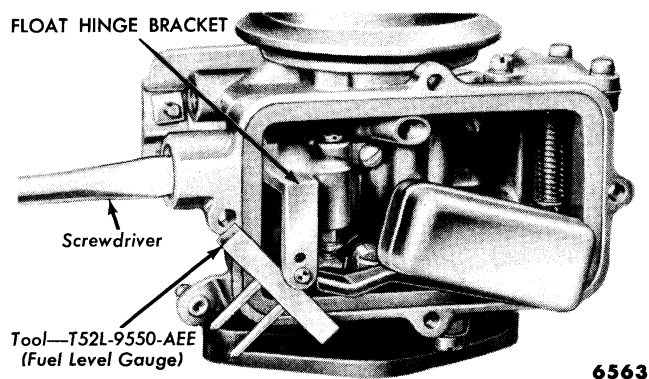

Fig. 43—Float Hinge Bracket Alignment

(approximately 8-10 inch-pounds torque). Do not over-tighten these screws as the bowl may crack. Install the inlet fitting and gasket. Install the dashpot if so equipped.

(3) **ASSEMBLE THROTTLE BODY TO MAIN BODY.** Place a new throttle body to main body gasket on the throttle body, and check the alignment of all holes in the gasket with the corresponding holes in the throttle body. Insert the two throttle body screws and lock washers through the throttle body and gasket to maintain gasket alignment, then set the main body on the throttle body. Invert the carburetor, and tighten the two throttle body screws evenly. Insert the upper end of the pump link through the hole at the end of the pump operating lever, and install the cotter pin.

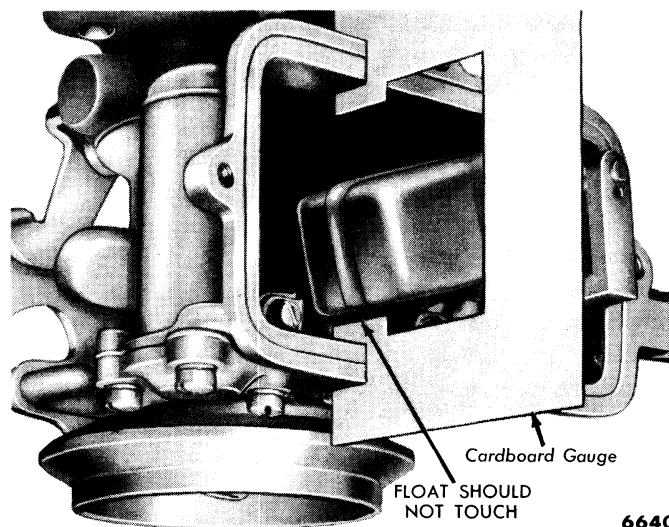

Fig. 44—Float Setting—Bench Test Only

e. Installation.

If the carburetor to intake manifold gasket is not serviceable, install a new one. Place the carburetor on the manifold, and secure it with the lock washers and nuts. Tighten the nuts evenly. Connect the choke and throttle linkage to the carburetor, and adjust if necessary. Connect the fuel line and the distributor vacuum line. Install the air cleaner and tighten the clamp. Be sure the air cleaner gasket is in place. Adjust idle fuel mixture, engine idle speed, and the dashpot (Fordomatic). Check the fuel level, and adjust if necessary.

6. DUAL CARBURETOR OVERHAUL

The procedures for removing, overhauling, and installing the dual carburetor are covered in this section under appropriate headings.

a. Removal.

Remove the air cleaner. Disconnect the accelerator rod at the carburetor. Disconnect the heat tube at the choke housing. Disconnect the distributor vacuum line and the fuel line. Remove the carburetor hold down nuts and lock washers, then lift the carburetor off the manifold.

b. Disassembly.

The throttle plate and shaft should not be removed from the throttle body. If the throttle plates are damaged, replace the throttle body assembly. If the choke plate or shaft is damaged, replace the air horn assembly.

(1) **THROTTLE BODY AND AIR HORN REMOVAL.** Remove the hairpin clips and washers retaining the fast idle rod, then remove the rod. Remove the screws holding the throttle body to the main body

(fig. 45). Remove the accelerator pump link. Lift the throttle body and gasket from the main body. Remove the screws holding the air horn on the main body. Lift the air horn from the main body.

(2) **MAIN BODY DISASSEMBLY.** Remove the accelerating pump rod stud, then lift the accelerating pump assembly from the main body (fig. 46). Remove the screws from each nozzle bar clamp, and remove the clamps. Lift the pump discharge nozzle and the two nozzle bars from the main body. Remove the two main jet plugs and gaskets from the main body. Remove the two main jets as shown in fig. 47. Remove the power valve and gasket. Remove the pump check ball retainer from the main body. A tool for this operation can be made by bending the end of a small wire to form a hook. Insert the hook in the bore, and engage the end of the retainer. Turn the assembly upside down, be sure to catch the pump check ball and pump discharge needle. Remove the idle tubes from the nozzle bars.

(3) **AIR HORN DISASSEMBLY.** Remove the float lever shaft, float, and float needle valve from the air

horn (fig. 48). Remove the float needle valve seat with a jet wrench. Remove the fuel inlet fitting and gasket.

Remove the three choke cover retaining screws, then remove the cover, gasket, and shield. Remove the choke lever retaining nut, lock washer, and spacer. Slide the choke lever off the shaft, and lift the piston out of its bore. Remove the two choke housing retaining screws, then remove the choke housing and gasket.

(4) **THROTTLE BODY DISASSEMBLY.** Remove the two idle adjusting screws and springs. Remove the spark control valve and gasket.

Usually it will not be necessary to remove the throttle plates or shaft; however, removal of these parts may be necessary, in some instances, to accomplish a thorough cleaning job. When the throttle plates are removed, mark them for assembly in the same throats from which they were removed. Upon installation, hold the throttle plates in the closed position as the screws are tightened.

c. Cleaning and Inspection.

Many carburetor troubles are the result of deposits

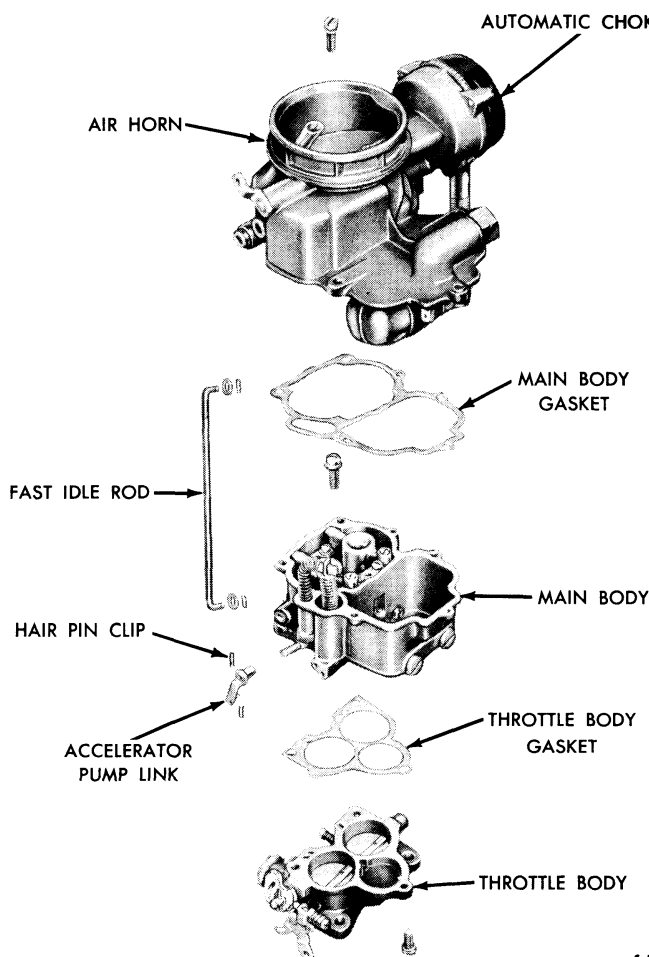

6558

Fig. 45—Throttle Body, Main Body, and Air Horn—Disassembled

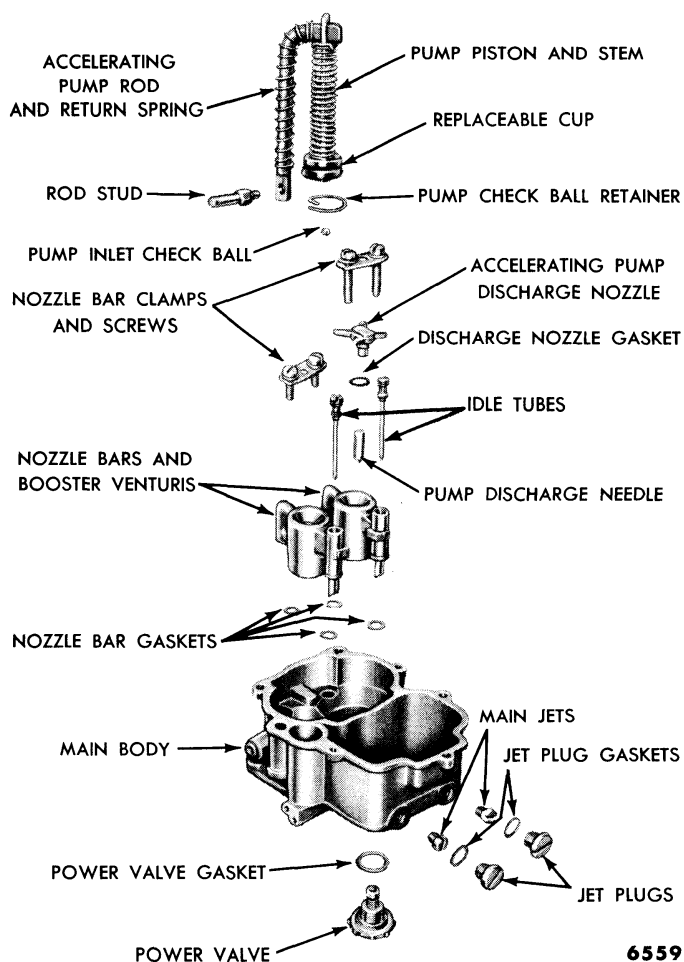

6559

Fig. 46—Main Body—Disassembled

accumulating in the carburetor. A thorough cleaning must be performed to assure satisfactory performance.

Clean all parts, except the carburetor power valve, the accelerating pump piston, and the spark control valve, in a cleaning solvent. Cleaning solvent may damage the rubber parts of these assemblies. Discard all gaskets.

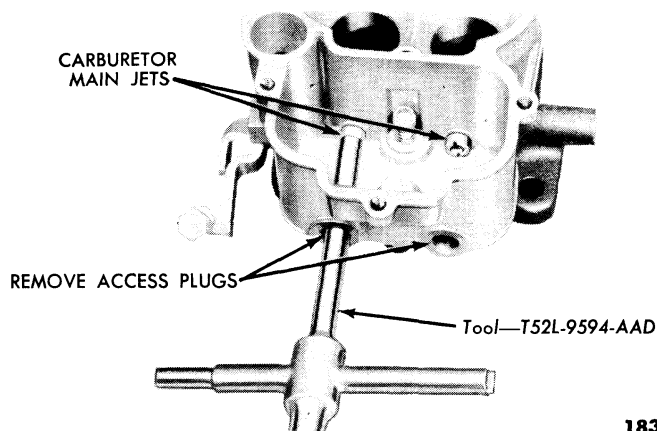

1831

Fig. 47—Main Jet Removal

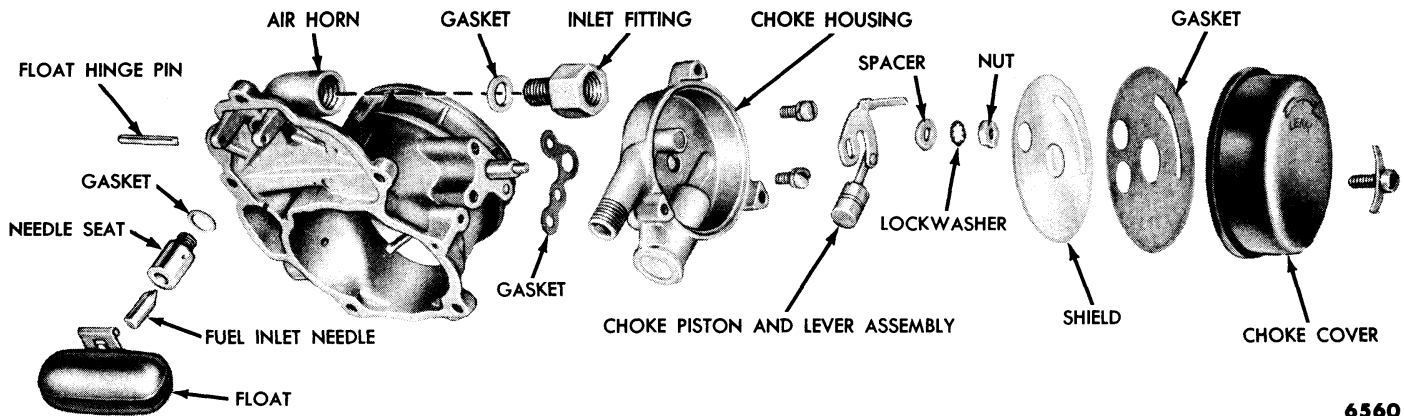

6560

Fig. 48—Air Horn—Disassembled

(1) **THROTTLE BODY.** Make certain that any gum varnish, or other deposits are removed from the throttle bores.

Replace the idle adjusting needles if a ridge is visible on the valve surfaces of the needles.

Examine the spark control valve gasket mating surface, and replace the throttle body if this surface is damaged so the gasket will not seal properly. Check the spark control valve stem and diaphragm for binding by moving the valve stem manually. If binding or stickiness is evident, replace the spark control valve assembly.

(2) **MAIN BODY.** Clean all passages with compressed air. Replace the main body if it is cracked, has nicks large enough to permit leakage at any gasket surface, or if it has stripped threads.

Inspect the accelerating pump, and replace the pump piston spring if it is broken. Replace the pump piston if it is worn or damaged.

Inspect the idle tubes and replace them if they are plugged, bent, broken, or the screw driver slots are damaged. Replace the pump discharge needle if it is ridged. Replace the pump discharge nozzle if it is plugged, broken, or damaged in any way.

Examine the power valve gasket mating surface, and replace the main body if this surface is damaged so the valve gasket will not seal properly. This would cause fuel to leak into the lower body and affect the fuel mixture. Check the power valve stem and diaphragm for free movement. Test the power valve as shown in fig. 36.

(3) **AIR HORN.** Replace the air horn if it is cracked or has nicks large enough to permit leakage at any gasket surface.

Open and close the choke plate several times to assure that the plate or shaft is not loose or binding. Replace the air horn assembly if necessary.

Inspect the float for leaks by holding the float under water that has been heated to just below the boiling point. Bubbles will appear if the float leaks. If the float

leaks, replace with a new float. Polish the needle contact surface of the float arm. Replace the float if the arm contact surface is grooved.

Inspect the fuel inlet needle valve and seat. Replace both parts if either part is worn as the fuel inlet needle valve and seat are matched in sets.

(4) **AUTOMATIC CHOKE.** Replace the choke cover if it is cracked, if the gasket surface is chipped, or if the thermostatic spring is broken, or damaged from excessive heat. Replace the choke piston and lever assembly if the piston is scored, or if the rivet is excessively loose. Check the choke housing for cracks, and replace if necessary. Clean all parts with solvent and compressed air. Make sure all the carbon is removed from the choke piston and the piston bore.

d. Assembly.

Always use new gaskets when rebuilding the carburetor. A gasket kit and a repair kit are available.

(1) **ASSEMBLE AIR HORN.** Position the choke housing and gasket on the air horn, then install the retaining screws. Drop the choke piston into its bore, position the choke lever on the shaft, then install the spacer, lock washer, and nut. Position the shield and cover gasket on the choke housing. Install the choke cover, making sure the choke lever is properly engaged in the end of the thermostatic spring. Start the three cover retaining screws, adjust the cover to the mid-position, then tighten the cover screws.

Install the fuel inlet fitting and a new gasket. Install the fuel inlet needle seat and a new gasket. Be sure to tighten the needle seat securely. Install the float needle valve in its seat, position the float, then install the float lever shaft.

(2) **ASSEMBLE MAIN BODY.** Install the proper size main jets recommended for the altitude at which the vehicle is primarily operated (see "Specifications"). Install the power valve, using a new nylon gasket, and tighten the valve to specifications. Position the pump

discharge needle, then seat it with a soft brass drift and light hammer. Place the pump discharge nozzle, and a new gasket in the main body.

Install the idle tubes in the nozzle bars, then check the idle tubes to make sure they do not touch the sides of the main well tubes. Place four new nozzle bar gaskets in position in the main body, then place the nozzle bars in position with the idle tube end toward the fuel bowl, and secure them with the two nozzle bar clamps.

NOTE: *The two long screws are used in the nozzle bar clamp at the pump discharge side of the carburetor throat.*

Install the pump check ball. Seat the ball with a soft brass drift and light hammer, then install the retainer. Install the accelerator pump assembly, then install the stud on the end of the pump operating rod.

(3) **ASSEMBLE THROTTLE BODY.** Install the idle fuel adjusting needles and springs in the throttle body. Turn the needles in gently with the fingers, until they just touch the seats, then back them off 1 turn for preliminary idle adjustment. Install the spark control valve with a new gasket.

7. FOUR-BARREL CARBURETOR OPERATION, ADJUSTMENTS, AND OVERHAUL

The four-barrel carburetor combines the performance characteristics of the earlier dual concentric models with added features which improve engine breathing and fuel distribution (fig. 49). The two primary stage (front) throats each contain a primary and booster venturi, main fuel discharge nozzle, throttle plate, transfer tube, and

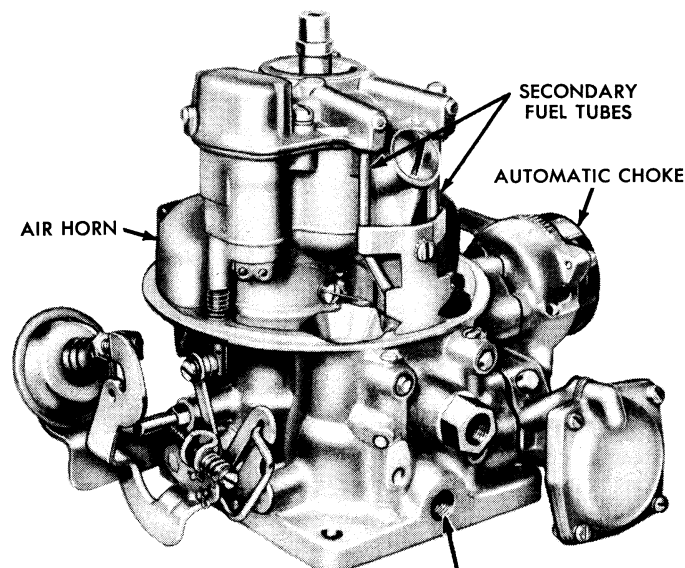

Fig. 49—Four-Barrel Carburetor

(4) **THROTTLE BODY AND AIR HORN INSTALLATION.** Place a new throttle body gasket on the main body. Secure the throttle body to the main body with three screws and lock washers. Place a new gasket on the main body, and secure the air horn to the main body with the screws and lock washers. Install the dashpot assembly at the same time, if Fordomatic equipped. Install the accelerator pump link, making sure to use the correct adjustment hole. Install the fast idle rod between the choke lever and fast idle cam with the washers and hair pin clips.

e. Installation.

Position the gasket on the manifold. Use a new one if necessary. Place the carburetor on the manifold, then install the lock washers and nuts. Alternately tighten the nuts to 12-15 foot-pounds torque. Connect the choke heat tube and the throttle linkage to the carburetor. Connect the fuel line and the distributor vacuum line. Place the air cleaner on the carburetor, and tighten the clamp. Adjust the idle fuel mixture and the engine idle speed.

idle system fuel passages. The choke plates, mounted in the air horn between the throttle body and main body, are controlled by an automatic choke mechanism mounted on the throttle body.

The two secondary stage (rear) throats each have a main venturi and a throttle plate. The throttle plates

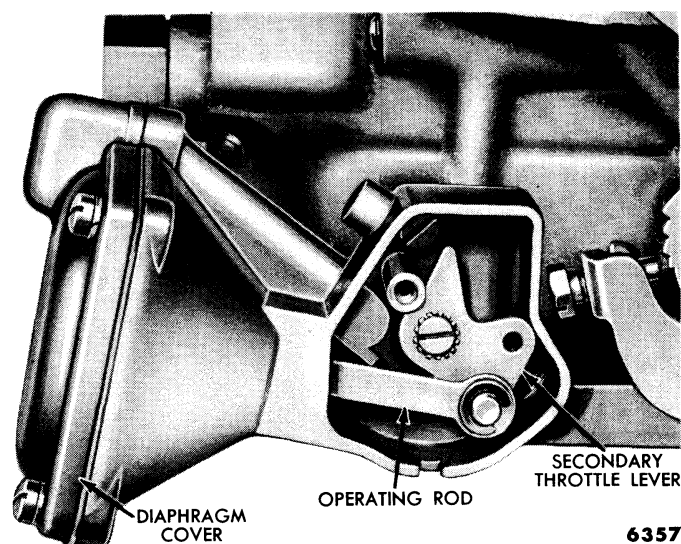

Fig. 50—Secondary Throttle Operating Diaphragm Assembly

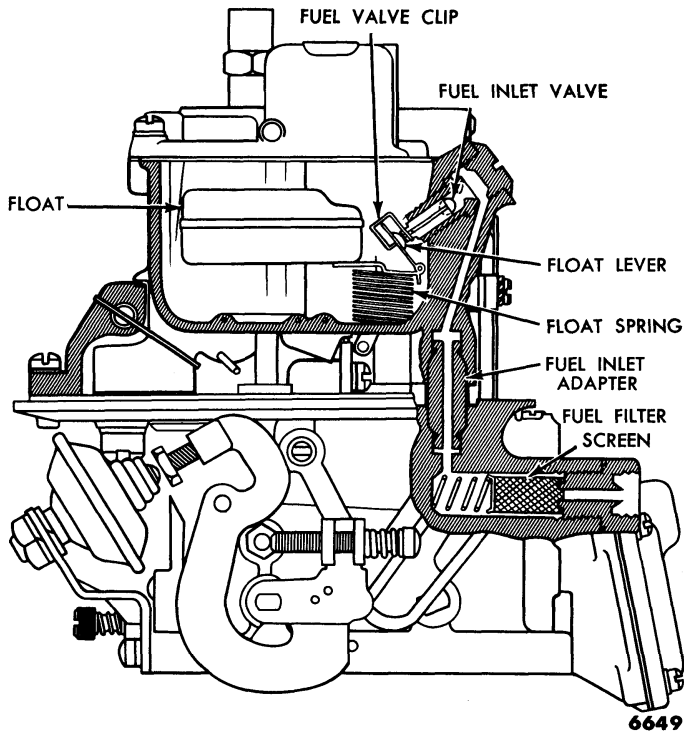

Fig. 51—Fuel Inlet System

are operated by a vacuum controlled diaphragm attached to the throttle body (fig. 50). Vacuum, to operate the diaphragm assembly which actuates the secondary stage throttle plates during periods of heavy engine loads or high speed operation, is obtained from a pas-

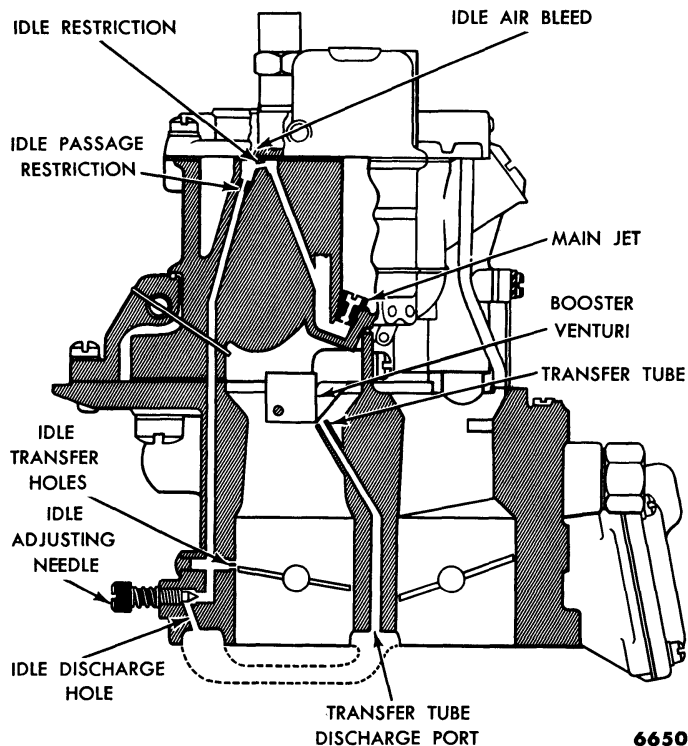

Fig. 52—Idle Fuel System

sage connecting the diaphragm chamber with the right primary and secondary stage venturis.

Fuel is supplied to the secondary stage throats by two tubes which extend from the float bowl cover into the throttle body secondary wells.

The carburetor is fully sealed within the air cleaner, using only filtered air which flows downward around the sides of the main body into the four throats in the throttle body. A locating feature provides indexing of the air cleaner mounting surface to the carburetor flange insuring proper installation of the air cleaner.

a. Operation.

To effectively provide the correct fuel-air mixture during all phases of engine operation, the carburetor is equipped with five basic fuel metering systems. They are: the main fuel system, the idle fuel system, the power fuel system, the accelerating system, and the vacuum operated secondary fuel system.

In addition to the five basic systems, a fuel inlet system regulates the supply of fuel to the various fuel systems, and an automatic choke system provides an enriched mixture to aid in starting and running a cold engine.

The operation of the various fuel systems is explained below.

(1) **FUEL INLET SYSTEM.** All of the fuel for the basic fuel systems enters the carburetor through the ball type fuel inlet needle valve and seat assembly (fig. 51). Movement of the needle valve in relation to the seat is controlled by the float and lever assembly which rises and falls with the fuel level. As the fuel level drops, the float lowers, opening the needle valve to allow fuel to enter the float chamber. When the fuel in the float chamber reaches a pre-set level, the float moves the needle valve to a position where it restricts the flow of fuel, admitting only enough fuel to replace that being used. Thus, any change in the fuel level causes a corresponding movement of the float, opening or closing the needle valve to maintain the pre-set level of fuel. The fuel inlet system must maintain this pre-set level, because the basic metering systems are calibrated to deliver the proper mixture only when the fuel is at the proper level.

A retracting clip is attached to the needle valve and hooks under the tab of the float assembly. This clip assures reaction of the needle valve to any movement of the float. A coil spring, located beneath the float tab, dampens any float vibrations that may be present.

(2) **IDLE SYSTEM.** At idle and low speed operation, the engine does not draw sufficient air through the booster venturi to create a vacuum great enough to operate the main metering system. Therefore, an idle speed fuel system is provided, which is not dependent

upon venturi vacuum, to discharge fuel (fig. 52). At idle and low engine speeds, intake manifold vacuum is high. This high manifold vacuum provides a pressure differential great enough to operate the idle fuel system.

At idle speed, the normal air pressure in the float chamber causes fuel to flow through the idle fuel system passages to the greatly reduced pressure area (vacuum) below the throttle plates. Fuel flows from the float chamber through the main jet and into the bottom of the main well. From the main well, it flows into the idle well and upward to the top of the idle well where it passes through two idle restrictions, then it passes into idle passage in the main body. The calibrated restrictions, in the top of the idle passage in the main body, meter the flow of fuel in the idle system. An air bleed, located in the cover above each idle passage in the main body, admits a metered flow of air to the idle system, and also serves as a vent to prevent any siphoning effect through the idle system at high engine speeds, or when the engine is stopped. The fuel continues down the idle passage in the throttle body and past the two idle transfer holes (Fordomatic), or one idle transfer hole (Standard and Overdrive) which act as additional air bleeds. This passage is fitted with an idle fuel mixture adjusting needle which controls the mixture. The idle system fuel flows around each idle mixture adjusting needle, through vertical passages, and into an equalizing slot, in the base of the carburetor throttle body, which leads to the primary and secondary throttle bores (fig. 53). These slots allow fuel to flow equally into both the primary and the secondary bores, insuring even distribution of idle system fuel throughout the manifold.

(3) **MAIN FUEL SYSTEM.** As engine speed increases, the air passing through the booster venturi creates a vacuum in the venturi. The amount of venturi vacuum is determined primarily by the air flow through the venturi, which in turn is regulated by the speed of the engine. The pressure differential in the venturi and float chamber causes fuel to flow through the main metering system (fig. 54).

At a predetermined throttle opening, fuel flows from the float chamber, through the main jets, and into the bottom of the main well. The fuel moves up the main well, into the main discharge nozzle, and past the air bleed slot and the small air bleed holes in the side of the main discharge nozzle. Air is supplied to the main discharge nozzle air bleeds from the main air bleed in the cover directly above the center of the main discharge nozzle. When air is added to the fuel the mixture of fuel and air is lighter than raw fuel, is more responsive to changes in venturi vacuum, and is vaporized more readily than raw fuel when discharged into the air stream in the venturi. Additional air from the aspirating air bleed enters the fuel as it passes from the tip of the main discharge nozzle to a vertical passage leading to

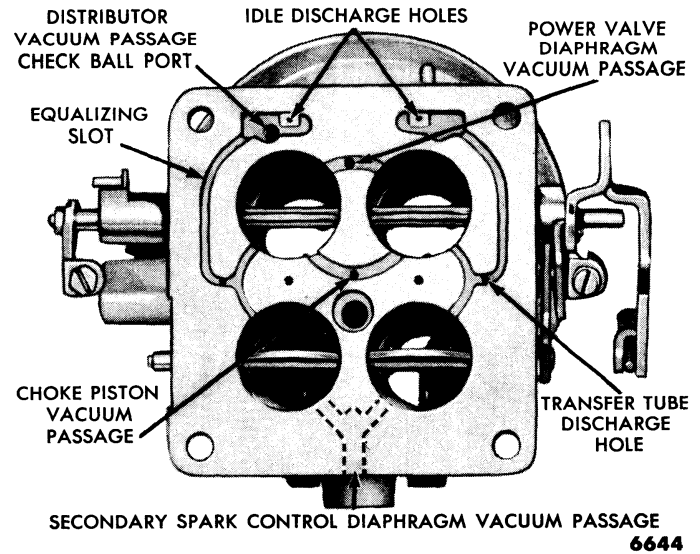

Fig. 53—Carburetor—Bottom View

the discharge tube. This mixture of fuel and air is discharged directly into the air stream in the booster venturi where vacuum is high. The throttle plate controls the amount of fuel-air mixture admitted to the intake manifold, thus regulating the speed and power output of the engine.

When the primary throttle plates are moved slightly beyond the idle transfer holes, fuel is discharged from the transfer holes as they are exposed to manifold vacuum. As the primary throttle plates are opened wider and engine speed increases, the air flow through

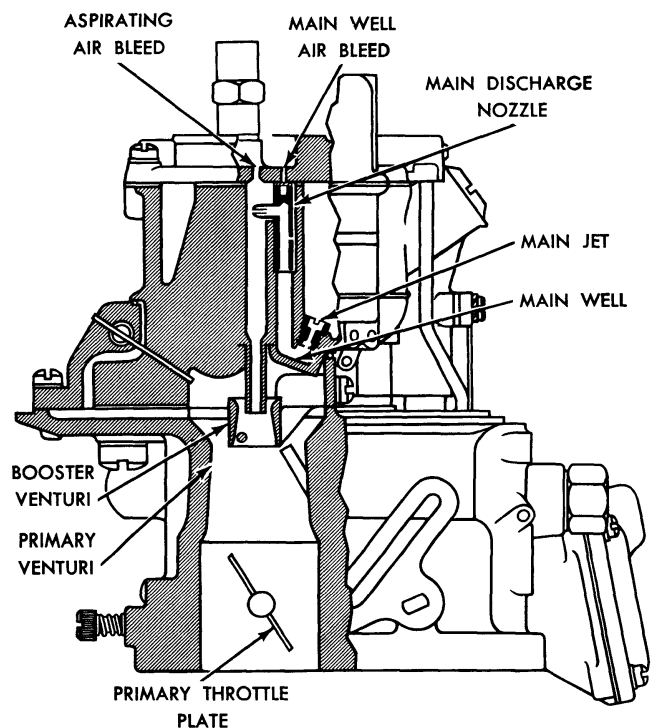

Fig. 54—Main Fuel System

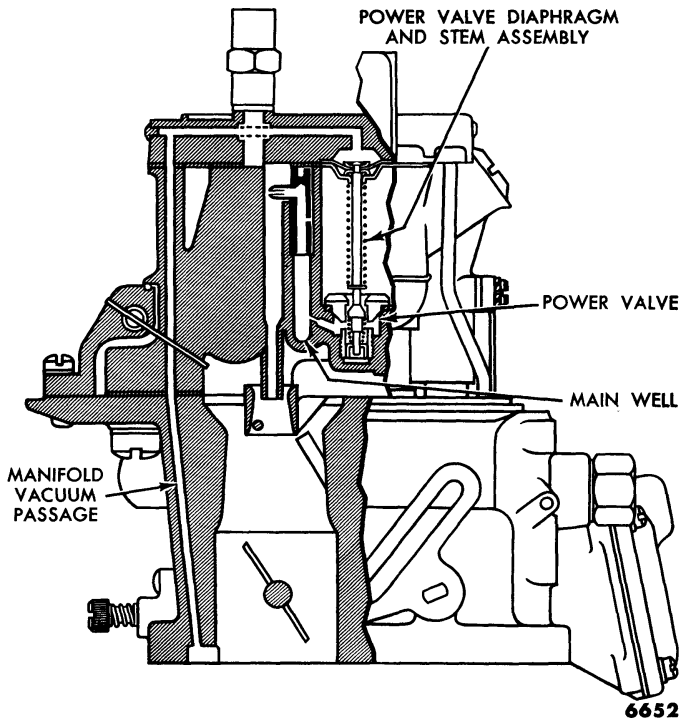

Fig. 55—Power Fuel System

the carburetor venturis is also increased, thus creating a vacuum in the booster venturis great enough to bring the main metering system into operation. The fuel flow from the idle fuel system tapers off as the main metering system begins to operate. The operation of the two systems is designed to provide a smooth transition from the idle system to the main fuel system.

Each primary venturi also contains a transfer tube directly below the booster venturi. Upon deceleration, the transfer tube siphons off any excess fuel remaining

in the main discharge tube, and transfers it to the idle system equalizing slots (fig. 53). The transfer tube also serves as an additional idle air bleed during idle system operation.

(4) **POWER FUEL SYSTEM.** During periods of high power operation, the carburetor has a tendency to lean out as the air flow is increased. To supplement the main and secondary fuel systems, additional fuel is required to maintain the proper fuel-air ratio. The added fuel required during this period is supplied by the power fuel system (fig. 55).

The power fuel system is controlled by manifold vacuum, which gives an accurate indication of the power demands placed on the engine. Manifold vacuum is highest at idle speed and decreases as the load on the engine is increased.

Manifold vacuum is transmitted from an opening in the base of the throttle body, through a passage in the throttle body, main body, and main body cover, to the top of the power valve diaphragm. The manifold vacuum, acting on the power valve diaphragm at idle speed or normal road load condition, is great enough to hold the power valve diaphragm stem from contacting the power valve pin located directly below the stem. When high power operation places a greater load on the engine, manifold vacuum drops below a predetermined value, then the spring-loaded stem of the power valve diaphragm overcomes the reduced vacuum at the top of the diaphragm and extends downward. This depresses the pin in the center of the power valve and opens the valve. Fuel from the float chamber is now free to flow into the power valve and, through holes in the side of the power valve body, into passages leading to both main fuel wells. The fuel from each main well flows into the main metering system, thereby supplementing the fuel flow through the main jets.

As engine power demands are reduced, manifold vacuum increases. The increased vacuum overcomes the tension of the spring-loaded stem of the power valve diaphragm and draws the stem up from the pin on the power valve, closing the valve and shutting off the added supply of fuel.

(5) **SECONDARY SYSTEM.** To provide sufficient fuel-air mixture to operate the engine at maximum power, the mixture supplied by the primary stage of the carburetor is supplemented by an additional quantity of fuel-air mixture from the secondary system (fig. 56).

This additional supply of fuel-air mixture is delivered through the two secondary (rear) throats of the carburetor. The secondary stage throttle plates are operated by a spring-loaded vacuum diaphragm assembly attached to the side of the throttle body and linked to the secondary throttle shaft.

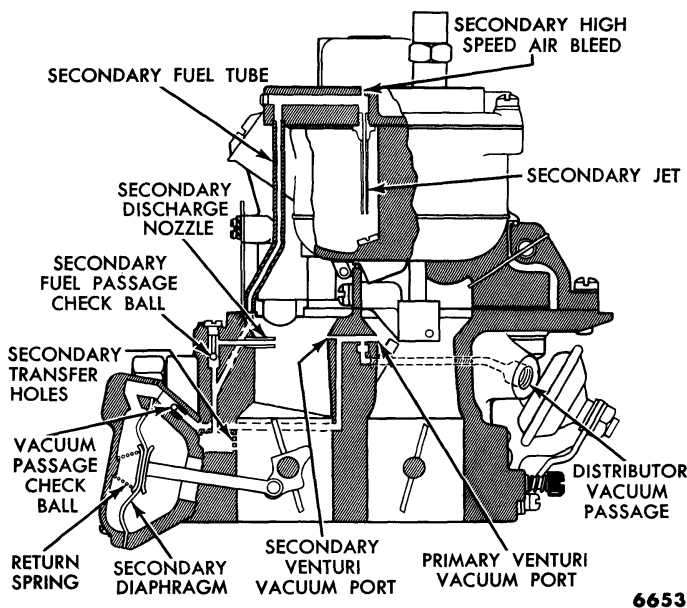

Fig. 56—Secondary System

Opening of the secondary throttle plates is controlled by vacuum from the right primary and secondary venturis. When operating at moderate speeds, the primary venturi vacuum, which would normally start to open the secondary throttle plates, is bled into the right secondary venturi. This bleed back of primary venturi vacuum prevents the secondary throttle plates from opening too soon.

As the primary throttle plates are opened further, primary venturi vacuum increases sufficiently to overcome the bleed back into the secondary venturi. Primary venturi vacuum then starts to act on the secondary system operating diaphragm, which in turn starts to open the secondary throttle plates. The bleed back hole in the right secondary venturi now becomes a vacuum passage which delivers secondary venturi vacuum to the diaphragm, assisting primary venturi vacuum in further opening the secondary throttle plates.

Three transition holes are located in each secondary throttle bore just above the throttle plates. As the secondary throttle plates are moved slightly beyond each transition hole, fuel is drawn from the transition holes by manifold vacuum. The secondary fuel supply is cut off from the secondary main fuel outlets by two steel balls located in the secondary fuel passages in the throttle body. As the secondary throttle plates open further, secondary venturi vacuum increases sufficiently to lift the steel balls off their seats, allowing fuel to be expelled from the secondary main fuel outlets. The transfer holes now act as air bleeds.

A ball check, located in the vacuum passage in the diaphragm assembly, restricts the amount of venturi vacuum entering the diaphragm chamber. This controls the rate at which the secondary throttle plates are allowed to open.

When decelerating slowly, vacuum at the openings in the primary and secondary venturis decreases, and the secondary throttle plates begin to close. The ball check in the diaphragm vacuum passage will unseat when the throttle is closed quickly, allowing the low pressure on the vacuum side of the diaphragm to rapidly return to atmospheric pressure. Linkage on the opposite side of the secondary throttle shaft (coupled to the throttle lever) will mechanically overcome any lag in the vacuum system, closing the secondary plates immediately, thereby assuring rapid and positive engine deceleration.

(6) **ACCELERATING PUMP SYSTEM.** Upon acceleration, engine response would not be instantaneous unless some means were provided to supply an immediate amount of fuel during the short interval of time required for the other fuel systems to begin operating. The accelerating pump, which is connected by a link to the throttle lever, provides this immediate supply of fuel during acceleration periods (fig. 57).

When the throttle plates are closing, the accelerating pump piston moves upward, drawing fuel from the float chamber through the pump inlet check valve and into the pump chamber. A check valve, located at the bottom of the pump chamber, opens to allow fuel to enter the chamber, and closes to prevent a reverse flow when the pump is operated on its discharge stroke. The upper end of the pump operating rod fits around the stem of the pump piston and moves independently of the pump piston upon acceleration. When the throttle is opened, the pump operating rod is pulled down, compressing the pump piston operating spring. The pressure of the spring moves the pump piston slowly downward, forcing fuel through the accelerating pump system. This spring override feature assures a sufficiently long interval of discharge, regardless of how quickly the throttle is opened.

Pressure of the pump piston, acting on the fuel in the pump discharge passage, raises the pump discharge needle valve. The fuel then flows upward, past the unseated valve, and down a vertical passage in the main body to the two pump discharge nozzles. The fuel discharges from each nozzle into the air stream of each primary stage venturi.

The pump discharge needle valve seals the fuel discharge passage when the pump piston is not discharging fuel. This prevents siphoning of fuel from the pump chamber, by the suction action of the air stream at the discharge nozzles, during higher engine speeds. It also prevents air from entering the system when the throttle is being closed and the pump piston is drawing another supply of fuel into the pump chamber.

The accelerating pump rod is drilled to provide an outside vent for the float bowl. The vent operates only while the throttle plates are in the approximate closed

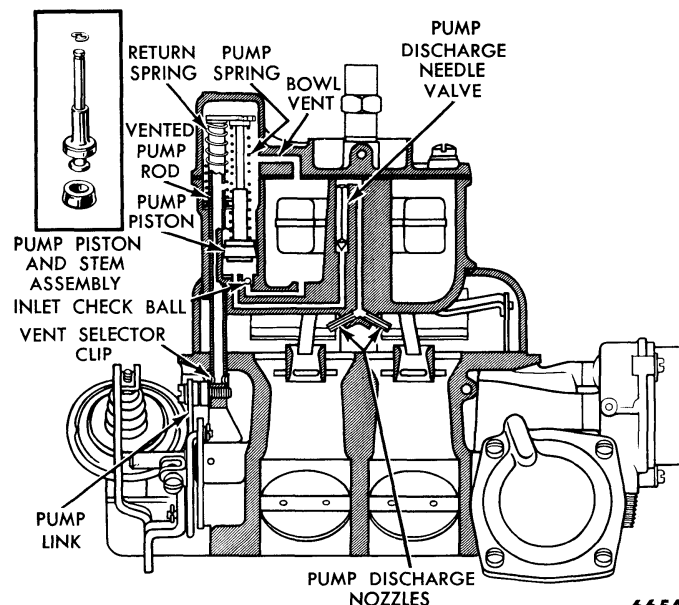

Fig. 57—Accelerating Pump System

position. A vent clip, at the bottom of the pump operating rod, can be raised to open or lowered to close the vent hole. The vent hole should be open during hot weather to allow fuel vapors to escape, thereby improving hot engine starting. Close the vent in cold weather, as any vapors which may be present will assist engine starting.

(7) **AUTOMATIC CHOKE SYSTEM.** When a cold engine is being started, much of the fuel discharged by the carburetor is unable to vaporize during its travel to the combustion chamber until sufficient heat is developed in the intake manifold to maintain a homogeneous mixture for efficient combustion. Therefore, a much larger quantity of fuel must be supplied to compensate for this lack of vaporization when starting and running a cold engine.

The choke plates (fig. 58), located in the air horn above the primary stage venturis, when closed, provide a high vacuum above as well as below the throttle plates. With a vacuum above the throttle plates, fuel will flow from the main system as well as from the idle system, thus bringing about the extremely rich mixture necessary for cold engine operation.

The carburetor choke shaft is linked to a thermostatic choke control mechanism, mounted directly on the throttle body.

The bi-metal thermostatic spring in the choke control mechanism will unwind when cold and wind up when warm. When the engine is cold, the thermostatic spring, through attaching linkage, holds the choke plates in a

closed position. Manifold vacuum, channeled through the throttle body and a passage in the choke control mechanism, draws the choke vacuum piston downward, exerting an opening force on the choke plates. When the engine is started, manifold vacuum, acting directly on the piston located in the choke housing, and the flow of air acting on the offset choke plates, immediately moves them against the tension of the thermostatic spring to a partially open position to prevent stalling. As the engine continues to run, manifold vacuum, acting on the choke vacuum piston, draws filtered air from the carburetor through an air heater tube in the intake manifold heat chamber where the air is warmed by the engine heat. The warmed air then enters the choke housing and heats the bi-metal spring, causing it to contract. The tension of the bi-metal spring gradually decreases as manifold temperature rises, allowing the applied vacuum on the choke piston to further open the choke plates. The air then flows through a passage and is exhausted into the intake manifold.

When the engine reaches its normal operating temperature, the bi-metal spring no longer exerts an opposing tension on the choke piston, allowing the piston to pull the choke plates to the full open position. In this position, the choke piston is at its lowest travel in the cylinder. Slots in the piston bore allow sufficient air to bleed past the piston and into the intake manifold, causing a continual flow of warm air to pass through the thermostat housing. The bi-metal spring thus remains heated and the choke plates remain fully open until the engine is stopped and allowed to cool.

If the engine should reach the stall point during the warm-up period, manifold vacuum will drop considerably. The tension of the bi-metal spring then overcomes the lowered vacuum acting on the choke piston, and the choke plates will be moved toward the closed position, providing a richer mixture to help prevent engine stalling.

The automatic choke is provided with an adjustment to control its reaction to engine temperature. By loosening three screws that retain the plastic cover, it can be turned in a clockwise direction, which will require a higher engine temperature to fully open the choke plates. Turning the cover in the opposite direction (counterclockwise) will cause the choke plates to fully open at a lower engine temperature. This is the lean direction as indicated by the arrows on the cover. Proper adjustment will be very close to the mid-position mark as indicated by the divisions on the housing.

The linkage between the choke lever and the throttle shaft is designed so the choke plates will partially open when the accelerator pedal is depressed to the wide open position of the throttle. This permits unloading of a flooded engine. The linkage also holds the fast idle

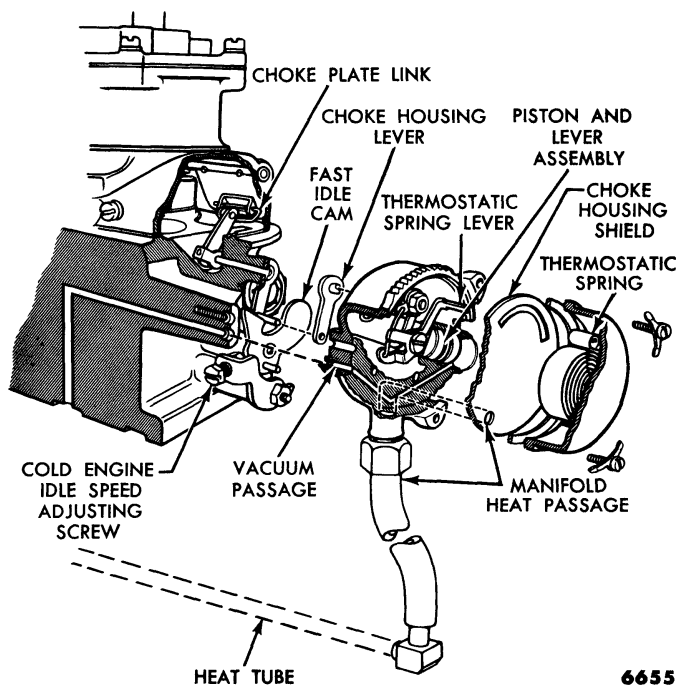

6655

Fig. 58—Automatic Choke System

cam to a fast idle position until the engine has warmed up.

(8) **SPARK CONTROL VALVE.** A vacuum operated spark control valve, attached to the throttle body of the carburetor, controls manifold vacuum to the distributor and regulates the spark advance during acceleration periods except when the throttle is at or near the wide open position. When accelerating, the spark control valve closes off the manifold vacuum which operates the spark advance mechanism, preventing excessive spark advance. As the engine speed approaches the throttle setting of the carburetor, manifold vacuum increases sufficiently to open the spark control valve and advance the spark timing.

b. Adjustments.

The various adjustments necessary for proper carburetor operation are given in the following paragraphs:

(1) **IDLE SPEED ADJUSTMENT.** The engine idle speed must be adjusted to proper hot and cold settings.

(a) **HOT ENGINE IDLE SPEED.** Adjustment of the left side stop screw controls the hot engine idle speed (fig. 59). Clockwise rotation increases the engine idle speed. Counterclockwise rotation decreases the idle speed.

Set the hand brake. Place the transmission selector lever in neutral position. Operate the engine until the temperature has stabilized, and the choke fast idle cam is in the slow position.

NOTE: *Back off the cold engine idle speed adjustment screw prior to adjusting the hot engine idle speed.*

Back off the choke fast idle adjustment screw from the fast idle cam, then turn the hot engine idle adjustment screw in a direction to obtain 475-500 r.p.m. Open the throttle by hand and allow it to close normally. Recheck the hot engine idle speed.

On vehicles equipped with Fordomatic, place the selector lever in DR (Drive) position, and recheck the engine idle speed. Adjust the idle speed to 425-450 r.p.m. in DR (Drive) position if necessary. Adjust the cold engine idle speed setting.

NOTE: *When adjustment of the hot engine idle speed setting is made, it is also necessary to properly adjust the cold engine idle speed setting.*

(b) **COLD ENGINE IDLE SPEED.** The adjustment screw, on the right side of the carburetor contacts steps on the fast idle cam during the engine warm-up period and controls the cold engine idle speed (choke fast idle speed, fig. 59).

Adjust the hot engine idle speed to the recommended r.p.m. before attempting to set the cold engine idle speed. Make this adjustment with the engine at normal operating temperature.

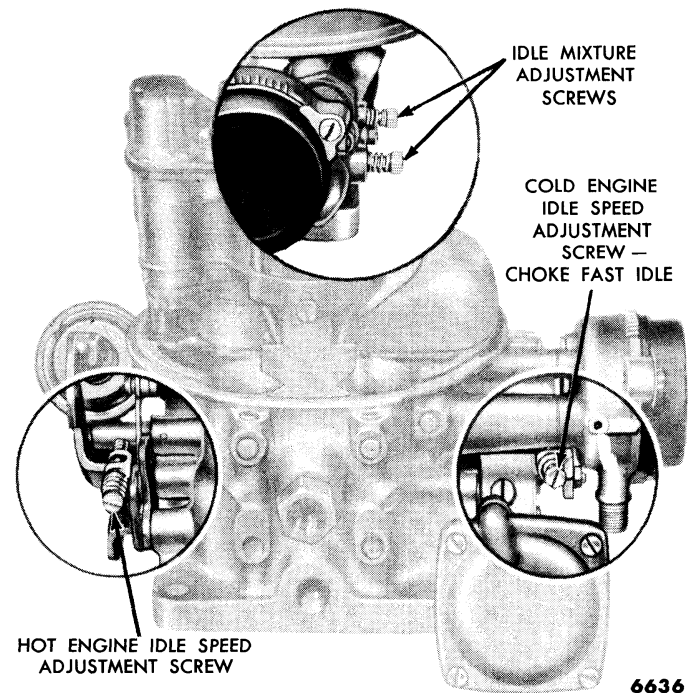

Fig. 59—Idle Adjustments

With the fast idle cam in the slow position, turn the cold engine idle speed adjustment screw in until it just touches the lowest step on the fast idle cam.

NOTE: *In localities where normal setting of the cold engine idle speed may be considered unnecessarily high, the cold engine idle speed may be reduced by backing off the adjusting screw not in excess of one full turn.*

(2) **IDLE MIXTURE ADJUSTMENT.** The idle fuel mixture to both primary and secondary throttle bores is controlled by two idle mixture adjusting screws located at the base of the throttle body (fig. 59). Proper adjustment is necessary in order to obtain a smooth engine idle.

To make the initial adjustment, turn the idle mixture screws "in" until they seat lightly, then back off each screw $\frac{5}{8}$ turn.

CAUTION: *Do not turn the adjustment screws too tightly against their seats, as this may groove the points. If an adjustment screw is damaged, it must be replaced before the proper idle mixture adjustment can be obtained.*

Run the engine at fast idle speed until the engine temperatures are stabilized. Place the choke fast idle cam in the slow position. Turn both mixture screws in until the engine begins to run rough from the lean mixture. Turn the screws out until the engine begins to "roll" from the rich mixture. Then turn the screws in until the engine begins to run smoothly. Always favor a slightly rich mixture rather than a lean setting. Each

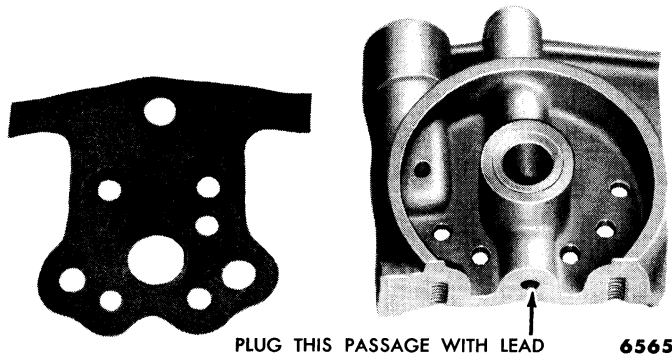

Fig. 60—Main Body Cover Sectioned

needle should be turned about the same amount. Final setting may vary $\frac{1}{2}$ turn difference between the screws.

If adjustment of the idle mixture has increased the engine r.p.m., reset the hot engine idle speed to the recommended r.p.m., then recheck the idle mixture.

(3) **ACCELERATOR PUMP STROKE ADJUSTMENT.** To satisfy acceleration requirements in various climates or altitudes, adjustment holes in the throttle lever allow the accelerator pump link to operate in one of two positions. The hole closest to the throttle shaft provides the shortest pump stroke and is suitable for average or hot weather operation. The outer hole is for cold weather operation. The position of the link may be changed as follows:

Remove the carburetor air cleaner. Remove the hair-pin clip which retains the pump link to the throttle lever. Remove the retaining screw from the pump rod. Place the pump link in the desired adjustment hole in the throttle lever, and secure it with the hairpin clip. Secure the pump link to the pump operating rod. Install the air cleaner. Tighten the air cleaner wing nut finger tight.

(4) **DASHPOT ADJUSTMENT.** With the engine at normal operating temperature and the fast idle cam in the slow position, hold the throttle lever in the closed position, and turn the dashpot adjusting screw out (counterclockwise) until the head of the dashpot adjusting screw pushes the dashpot rod to the end of its travel, and engine speed just starts to increase.

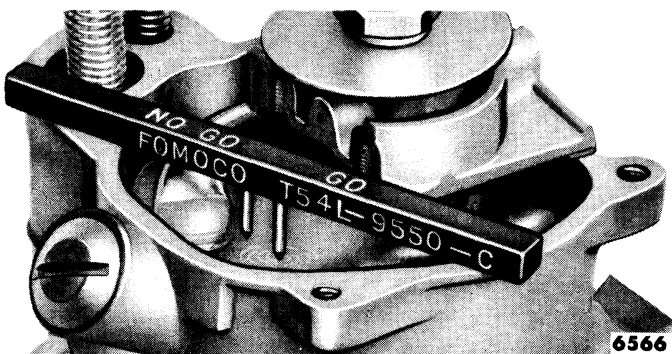

Fig. 61—Fuel Level Check

Turn the dashpot adjusting screw in (clockwise) $1\frac{1}{2}$ to 2 turns to obtain the specified end stop clearance of 0.045-0.064 inch.

(5) **SECONDARY DIAPHRAGM AND VACUUM SYSTEM CHECK.** To test the secondary vacuum system for air leakage, remove the carburetor from the engine. Remove the main body and air horn from the throttle body. Fully open (at the linkage) both the primary and secondary throttle.

Block off the secondary vacuum openings in the right primary and secondary venturi, and the distributor vacuum line fitting, with the fingers. Release the secondary throttle linkage with these openings blocked off while continuing to hold the primary throttle linkage open. If no leak exists, the secondary throttle plates should remain partially open.

To check the diaphragm assembly for air leakage with the carburetor on the engine, remove the complete diaphragm and housing assembly from the carburetor. Pull the diaphragm rod in a direction to compress the spring. Cover the slot located at the housing to carburetor mounting face with a finger in order to eliminate any air leakage at this point. Release the diaphragm rod. If no leak exists the spring should stay partially compressed.

(6) **FUEL LEVEL CHECK.** The fuel level can be checked with the engine running. A main body cover and gasket should be sectioned as shown in fig. 60. After the cover is sectioned, be sure to plug the power valve diaphragm vacuum passage with lead.

Remove the air cleaner and main body cover. Install the sectioned cover and gasket, place the fuel level gauge as shown in fig. 61, then start the engine. The fuel should touch the low pin on the gauge, but should not touch the high pin. If the fuel level gauge is not available, the fuel level should be $\frac{1}{2}$ inch \pm $\frac{1}{32}$ inch from the flange surface of the main body, with the engine idling. The fuel will maintain a $\frac{1}{16}$ - $\frac{1}{8}$ inch lower level at higher engine speeds.

Bend the float lever tab up or down to change the fuel level.

c. Carburetor Overhaul.

The procedures for removing, overhauling, and installing the carburetor are given in the following paragraphs.

(1) **REMOVAL.** Remove the air cleaner. Unhook the clip which secures the throttle rod to the throttle lever. Remove the throttle rod from the throttle lever. Disconnect the choke control heat tube and the fuel line from the carburetor. Disconnect the distributor vacuum lines from the carburetor. Remove the four nuts and lock washers which secure the carburetor to the mani-

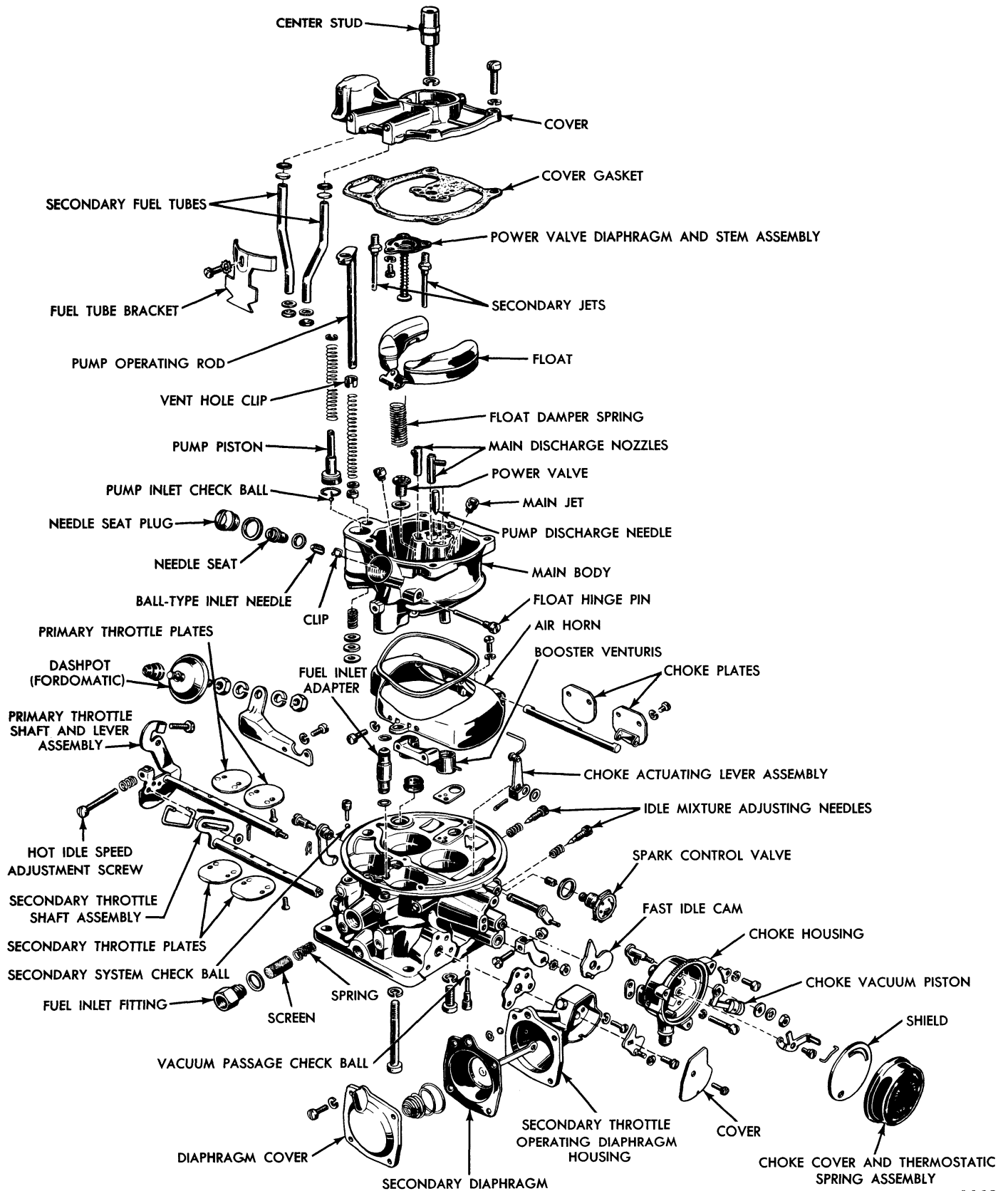

Fig. 62—Four Barrel Carburetor—Disassembled

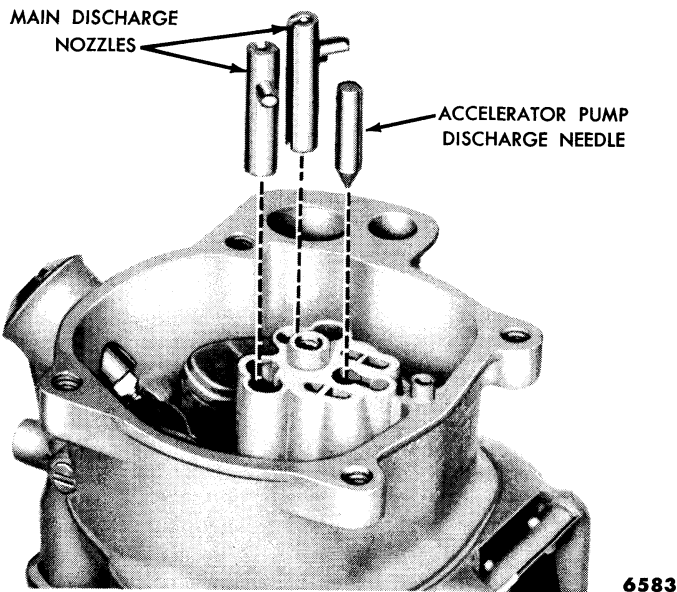

Fig. 63—Main Discharge Nozzles and Pump Discharge Needle

fold riser. Remove the carburetor from the engine, being careful that the choke fresh air supply tube slides free of the throttle body. Remove the spacer and two gaskets (one on each side of the spacer) from the riser on the intake manifold.

(2) **DISASSEMBLY.** Use a separate container for the component parts of the throttle body and the main body. Do not remove the throttle plates, unless necessary, as difficulty may be encountered when installing these parts to obtain correct positioning. It is not necessary to remove the choke plates from the air horn unless they are damaged or the shaft is binding. Remove the booster venturis only when damage makes replacement necessary. The carburetor is shown disassembled in fig. 62.

(a) **MAIN BODY.** Remove the center stud, and lock washer. Remove the cover retaining screws, then lift the cover off the main body. Remove the screw and bracket retaining the secondary fuel tubes. Remove the

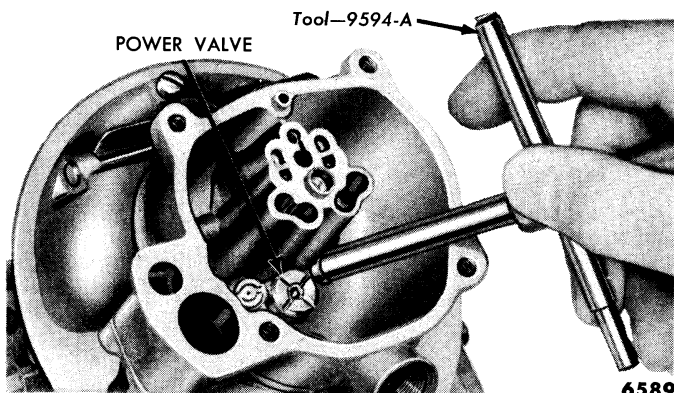

Fig. 64—Main Jet Removal

secondary fuel tubes by gently pulling them from the throttle body.

CAUTION: Do not bend the secondary fuel tubes.

Remove the accelerator pump link from the operating rod and throttle lever. Remove the stud and the vent clip from the lower end of the pump operating rod, then lift the pump assembly out of the main body. Remove the pump rod dust seal, washer, and spring. Remove the pump rod upper seal and washer.

Lift the main discharge nozzles out of the main body (fig. 63) with a pair of needle nose pliers. Use care not to damage the nozzles. Invert the carburetor, and catch the pump discharge needle as it falls out.

Remove the float inlet needle seat plug, then remove the inlet needle seat spring, and the seat. Unscrew the float hinge pin, and lift the float assembly out of the main body. Remove the float damper spring.

Remove the main jets (fig. 64), then remove the power valve.

Make a small hook on the end of a suitably sized piece of wire, then lift the accelerator pump inlet check ball retainer out of the pump well. Invert the carburetor, and catch the inlet check ball as it falls out.

Remove the secondary jets from the main body cover, remove the power valve diaphragm retaining screw, then remove the power valve diaphragm and stem assembly.

If necessary, disassemble the accelerator pump assembly. Slip the pump piston cup off the end of the piston stem. Compress the stem spring, pry off the stem retainer, then remove the stem and spring from the operating rod.

(b) **SEPARATE MAIN BODY, AIR HORN, AND THROTTLE BODY.** Remove the air horn to throttle body screw. Invert the carburetor, and remove the two throttle body to main body screws. Lift off the main body, and remove the main body gasket. Lift the air horn off the throttle body, and disengage the choke actuating lever from the choke plate, using care not to bend the lever.

(c) **THROTTLE BODY.** Remove the idle fuel adjustment needles and springs. Remove the three choke retaining screws, then remove the cover and gasket. Remove the choke heat shield. Remove the thermostatic spring lever, and the small wire connecting rod. Remove the three choke housing retaining screws, and remove the choke housing and gasket. Remove the nut, lock washer, and spacer, then slip the choke piston assembly out of the housing. Remove the lever from the back side of the choke housing. Remove the fast idle cam.

Remove the vacuum diaphragm housing cover plate. Remove the retainer which holds the diaphragm rod to the lever pin. Remove the screw holding the diaphragm

lever to the secondary throttle shaft, then remove the lever. Remove the screws which hold the diaphragm housing to the throttle body. Remove the diaphragm assembly and gasket.

Test the diaphragm assembly for leakage. If a leak is evident, remove the diaphragm cover (fig. 65). Remove the diaphragm spring, and the diaphragm. Remove the ball check retainer and the ball. Inspect the ball and ball seat for damage. The ball seat will be oval in shape, but should not have any nicks or scratches. Inspect the gasket surface and the diaphragm sealing surfaces for nicks or scratches which may cause a vacuum leak. Replace parts as necessary.

Remove the spark control valve and gasket. Remove the fuel inlet fitting, gasket, filter screen, and spring (fig. 66).

Remove the secondary fuel system check ball retainers, then invert the throttle body and catch the two balls as they fall out. Remove the vacuum passage check ball retainer from the bottom of the throttle body, and shake out the check ball. If so equipped, remove the dashpot and bracket assembly.

Usually it will not be necessary to remove the throttle plates or shafts; however, removal of these parts may be necessary, in some instances, to accomplish a thorough cleaning job. When the throttle plates are removed, mark them for assembly in the same throats from which they were removed. Upon installation, hold the throttle plates in the closed position as the screws are tightened. Hold the secondary plates closed against a piece of 0.004 inch feeler stock $\frac{3}{16}$ inch wide when tightening the screws.

When binding or damage makes it necessary, remove the choke lever assembly. Remove the pin from the end of the choke lever shaft, slide the shaft out of the throttle body, then remove the choke actuating lever assembly and the washer.

(d) **AIR HORN.** Remove the choke plate screws, and the choke plates. Slide the choke plate shaft out of the air horn. Remove the lock wire from the booster venturi screws, then remove the screws.

(3) **CLEANING AND INSPECTION.** Many carburetor troubles are the result of deposits accumulating in the carburetor. A thorough cleaning must be performed to assure satisfactory performance.

(a) **CLEANING.** Wash all carburetor parts except the accelerator pump rubber cup, power valve diaphragm, spark control valve, secondary throttle operating diaphragm, and dashpot assembly in a **CLEAN** solvent. Wipe the pump rubber cup, power valve diaphragm, and dashpot assembly with a clean, soft, dry cloth. Do not use a wire brush to clean any parts. Dry the parts with compressed air, and place them on a clean bench. Force dry, compressed air through all passages of the



Fig. 65—Diaphragm Cover Removal

throttle body, main body, and main body cover.

(b) **INSPECTION.** Inspect the choke shaft and plates, and the throttle shafts and plates. If the primary throttle shaft is excessively loose or binds in the throttle body, or if the throttle plates are burred, preventing proper closure, the throttle body assembly should be replaced.

Inspect the throttle body, main body, main body cover, and air horn for cracks or leaks. Check the action of the power valve diaphragm. If tests indicate the diaphragm to be defective, remove the diaphragm cover. Blow out the vacuum passage to the diaphragm with



Fig. 66—Fuel Inlet Fitting, Screen, and Spring

compressed air, and install a new assembly.

IMPORTANT: *See the assembly procedure for installing a new power valve diaphragm.*

To check the operation of the power valve diaphragm press down on the stem, cover the vacuum passage in the cover with the thumb, and release the stem. If the diaphragm or center bushing does not leak, the stem will not return all the way down. If the stem does go to the limit of its travel, repeat the check, this time covering both ends of the center bushing, as well as the vacuum passage. If the stem holds steady now, the bushing is leaking, and the main body cover should be replaced. If the stem leaks down all the way, replace the diaphragm and stem assembly.

Inspect the main discharge nozzles, main metering jets, secondary jets, ball check valves, and idle restrictions. If any of the openings are blocked, open them up with compressed air. Do not use a drill or wire to clean out any openings or passages in the carburetor. A drill or wire may enlarge the hole or passage, thus changing the calibration of the carburetor.

NOTE: *The power valve, main metering jets, and secondary jets are stamped with a number which identifies them as to their flow characteristics and not necessarily the drill size of the opening. For instance, a main jet stamped "55" will flow 55 cubic centimeters of fuel in one minute, under controlled conditions.*

If the screwdriver slots or threads of the main metering jets, or power valve are found to be damaged or burred, replace the parts. If the power valve pin is bent, replace the power valve assembly.

Check the accelerator system discharge nozzles. If the holes are blocked, open them with compressed air. Blow out the pump discharge passages in the main body.

Observe the condition of the ball-type float needle and needle seat. If the ball-type needle is nicked or grooved, replace both the needle and the seat, as these parts are furnished as matched assemblies.

Check the accelerator discharge needle. If the needle is nicked or grooved, replace it. Note the condition of the needle seat in the main body. Check the accelerator pump ball check valve. If the ball is nicked or corroded, replace the ball. Check the condition of the ball seat.

Inspect the accelerator pump piston rubber cup. If it is worn or defective, replace it with a new cup. Inspect the accelerator pump operating rod. If the finish is rough, polish the rod with crocus cloth or fine emery cloth. Lubricate the accelerator pump rod with graphite grease before assembly.

Inspect the rubber "O" ring seals on the fuel inlet fitting. Replace if worn or defective.

Clean the idle adjusting screw threads, and inspect the threads and needle faces. Replace the needles if they are grooved or bent.

If the carburetor is equipped with a dashpot, inspect the rubber boot for proper installation in the groove of the stem bushing. Check the stem movement for smooth operation. Do not lubricate the stem. Replace the dashpot assembly if it is defective.

Inspect all gasket surfaces. Repair or replace any parts that are damaged. Replace the choke cover if it is cracked, if the gasket surface is chipped, or if the thermostatic spring is broken. Check the choke housing for cracks, and replace if necessary. Make sure all the carbon is removed from the choke piston and the piston bore.

Install all the new gaskets and parts furnished in the carburetor overhaul kit. Make sure all holes in the new gaskets have been properly punched and that no foreign material has adhered to the gaskets.

(4) **ASSEMBLY.** Assemble the carburetor in the following sequence.

(a) **AIR HORN.** Install the booster venturis with the two screws. Be sure to install a lock wire through the screws. Slide the choke plate shaft into the air horn, position the choke plates, hold them in the full closed position, and install the screws. The choke plate with the lever bracket on it is installed in the right hand port. Check the choke plates for free movement. If any binding is evident, loosen the screws and shift the choke plates to relieve the binding condition.

(b) **THROTTLE BODY.** Position the choke actuating lever assembly and the washer in the throttle body. Slide the choke lever shaft into position, and install the pin.

Install the dashpot and bracket assembly (if so equipped). Drop the distributor vacuum passage check ball into its port in the bottom of the throttle body, then install the retainer. Drop the two secondary fuel system check balls into their ports, seat the balls with a brass drift and light hammer, then install the retainers.

Drop the fuel inlet filter screen spring into the fuel inlet opening. Put a new gasket on the fuel inlet fitting, and install the filter screen on the end of the fitting. Install the fitting and screen assembly in the throttle body. Make sure the parts are installed in the order shown in fig. 66.

Install the spark control valve with a new gasket. Install the check ball and retainer in the secondary diaphragm housing. Install the housing on the throttle body, with a new gasket. Position the secondary diaphragm in the housing, place the spring on the diaphragm disk, then install the cover with the screws only finger tight. Pull the diaphragm rod past the secondary throttle lever as far as it will go, then tighten the cover screws. Connect the diaphragm rod to the link pin. In-

stall the secondary diaphragm housing cover.

Position the fast idle cam on the stud above the primary throttle shaft. Slide the choke piston into its bore. Insert the lever shaft in the back side of the choke housing, and into the piston lever. Install the spacer, lock washer, and nut. Position the small wire connecting rod in the thermostatic spring lever, then install the lever and connecting rod with the retaining screw. Place the heat shield and cover gasket in position, engage the thermostatic spring on the spring lever, then install the three cover retaining screws and clamps. Adjust the cover to the mid-position mark.

Install the idle fuel adjustment needles and springs.

(c) **ASSEMBLE THROTTLE BODY, AIR HORN, AND MAIN BODY.** Install new neoprene seals on each end of the fuel inlet adaptor. Coat the seals lightly with grease, then install the adaptor in the main body. Position the main body to throttle body gasket on the boss in the throttle body.

Drop the accelerator pump inlet check ball into its well. Seat the ball with a brass drift and a light hammer. Make sure the ball is free, then install the check ball retainer. Install a new cup on the accelerator pump stem. Place the stem spring on the stem, then compress the spring with the operating rod, and install the retainer. Place the pump operating rod seal and washer in the main body, then place the pump return spring on the pump operating rod. Install the pump assembly in the main body.

Slide the pump rod spring, washer, and felt dust seal over the end of the pump operating rod. Position the main body on the air horn. Carefully insert the choke actuating lever in the bracket on the back of the choke plate. Start the pump operating rod and the fuel inlet adaptor into their ports, then seat the main body and air horn assembly on the throttle body. Install the vent clip and the stud on the end of the pump operating rod. Invert the carburetor, install the two main body to throttle body screws and lock washers, and tighten to the specified torque. Install the air horn retainer screw.

(d) **MAIN BODY.** Position the power valve diaphragm and retainer in the main body cover. Install secondary jets of the proper size and the retaining screw finger tight. Compress the power valve stem, then tighten the secondary jets and the retaining screw.

Install the power valve. Install main jets of the size recommended for the altitude at which the car is to be primarily operated.

Assemble the ball-type fuel inlet needle and clip to the float assembly. Place the float damper spring over the boss in the main body. Place the float assembly in the float bowl with the inlet needle started into the needle seat boss and the tip of the damper spring engaged in the hole in the float arm. Install the float hinge pin with sealer on the threaded end.

Place a new "O" ring seal on the fuel inlet needle seat, then install the seat, making sure the ball-type inlet needle enters the seat properly. Place the inlet needle seat spring in position. Place a new gasket on the inlet needle seat plug, then install the plug securely.

Hold the float in the closed position, and measure the distance from the gasket surface of the main body to the toe of the float (fig. 67). This distance should be $\frac{1}{4}$ inch. Bend the float lever tab up or down to bring the float to the proper level. Make sure both float toes are at the same level. This adjustment should provide the proper fuel level.

Install the main discharge nozzles in the main wells. Make sure the nozzle tips are pointing away from each other after installation. It is possible to install the main discharge nozzles in the main discharge passages. If this is done, the nozzle tips will be pointing toward each other, and extremely poor operation will result.

Drop the accelerator pump discharge needle into its passage in the main body. Seat the discharge needle with a brass drift and light hammer.

Install new secondary fuel tube seals in the throttle body and the main body cover if necessary. Install the secondary fuel tubes in the throttle body, and secure them with the bracket and screw. Before installing the main body cover, install the carburetor on the engine, and check the fuel level.

(4) **INSTALLATION.** Place the carburetor on the intake manifold, and secure it with the nuts and lock washers. Tighten the nuts evenly in a criss-cross pattern. Install the fuel line and both distributor vacuum lines. Connect the accelerator linkage, and the choke heat tube. Install the air cleaner.

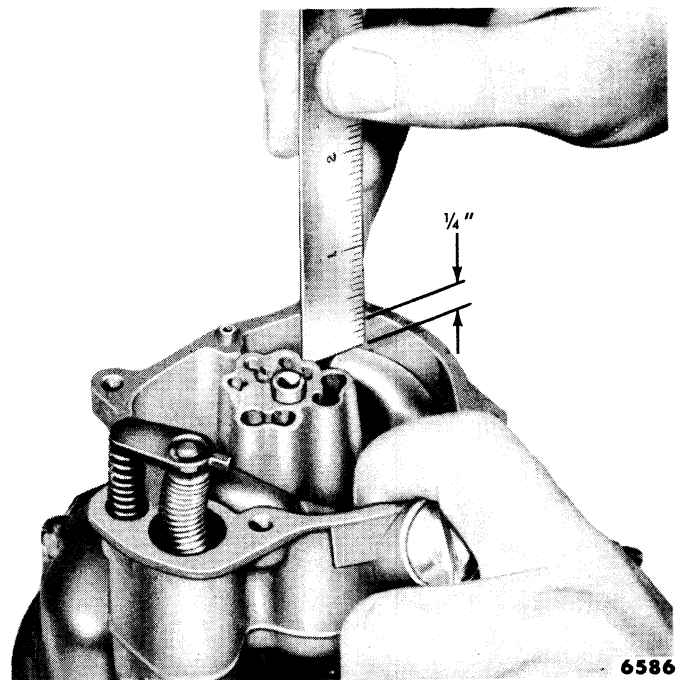

Fig. 67—Float Setting

8. FUEL PUMPS, VACUUM BOOSTER, AND FUEL FILTER

The fuel pump used on the 6-cylinder engine is mounted on the lower right center of the engine cylinder block. The fuel pump used on the 8-cylinder engine is mounted on the left side of the cylinder front cover. All fuel pumps are actuated by the camshaft eccentric.

A combination fuel pump and vacuum booster is standard equipment on cars equipped with Overdrive or Fordomatic.

The fuel filter used on the Thunderbird is not integral with the combination fuel pump. It is located in the fuel line between the fuel pump and carburetor.

a. Fuel Pump.

Fuel pump tests are performed as follows:

(1) **TESTING ON VEHICLE.** These tests are performed with the pump mounted on the engine.

(a) **PRESSURE TEST.** Disconnect the fuel line at the carburetor. Install a pressure gauge and a "T"-type fitting with a petcock between the gauge and the carburetor fuel inlet fitting.

Vent the system, by opening the petcock momentarily, prior to taking a pressure reading. Take a read-

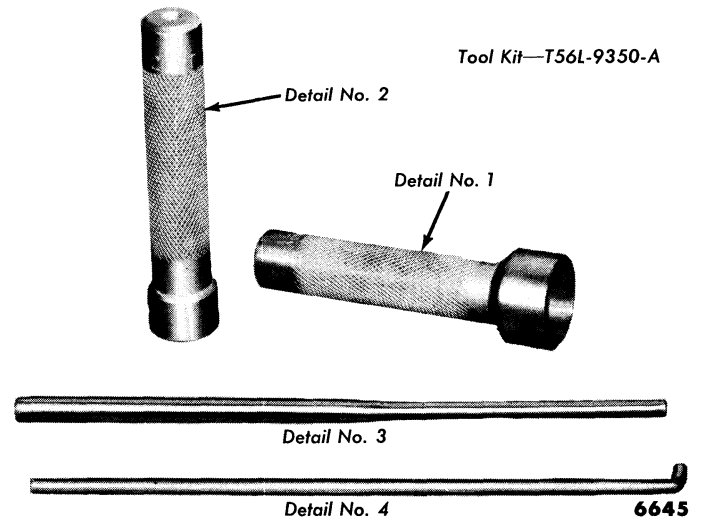

Fig. 69—Fuel Pump Overhaul Kit

ing as soon as the pressure has stabilized. Refer to "Specifications" for test readings.

(b) **CAPACITY TEST.** Perform this test only when the pressure test is within specifications. Open the petcock, and expel the fuel into a suitable container. Operate the engine at 500 r.p.m. and observe the time required to expel one pint. It should be 30 seconds or less.

NOTE: Do not condemn a fuel pump, as the result of a poor capacity test, until it is certain that the fuel filter is clean and in good condition.

(2) **REMOVAL.** Crank the engine to position the cam eccentric on the low side. Disconnect the fuel lines at the fuel pump. Remove the two retaining screws, then remove the pump and gasket.

(3) **DISASSEMBLY.** Remove the glass sediment bowl, gasket, and filter (fig. 68). Scratch a line on the pulsator chamber and body so that, on assembly, the inlet and outlet openings will be in the correct position. Remove the pulsator chamber and the pulsator diaphragm.

Drive out the rocker arm pin and plugs using the long drift (tool—T56L-9350-A, detail 3, fig. 69).

Hold the cover against the pump body, remove the cover retaining screws; then remove the cover.

Turn the diaphragm slightly to unhook the eye in the pull rod from the rocker arm, then remove the diaphragm and spring. Remove the rocker arm and spring. Scrape away the staking marks, and remove the pump rod seal. Scrape away the staking marks and flip the valves out with a screw driver.

(4) **CLEANING AND INSPECTION.** Clean the bowl, filter, cover, and pump body. Blow out all cover pas-

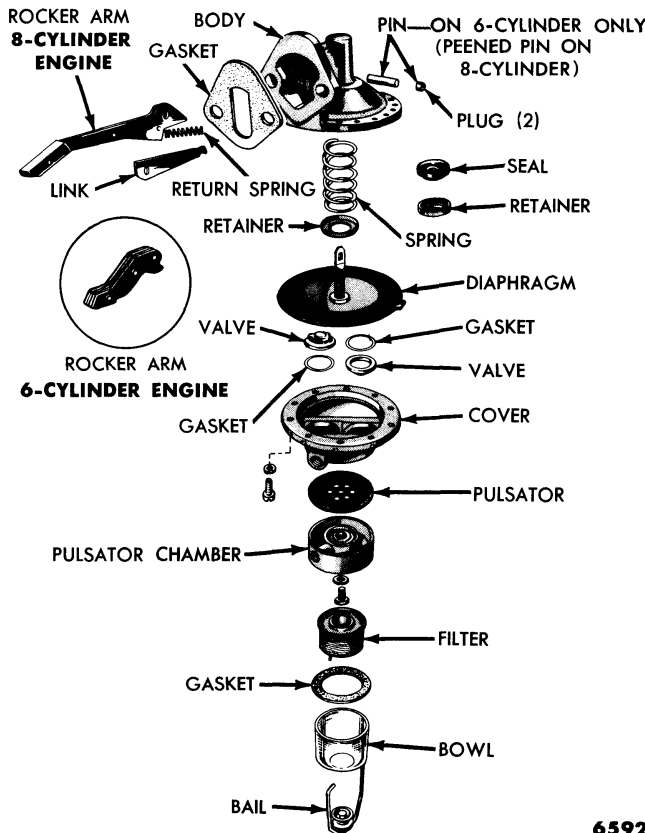

Fig. 68—Fuel Pump—Disassembled

sages. Inspect the body, cover, and bowl for cracks or damage. Remove any high spots around the staking marks that may distort the new valves upon installation. Inspect the pump mounting face for distortion. Replace the pump body or lap the mounting face if it is distorted. It is advisable to install the parts included in the repair kit when rebuilding the fuel pump.

(5) **ASSEMBLY.** Install a new pump rod seal and retainer with tool T56L-9350-A, detail 1. Stake the retainer in place. Lubricate the link, rocker arm bushing, and rocker arm with engine oil, then position them in the pump body and hold them in place with the tapered drift, detail 3, fig. 69.

Install the rocker arm pin. Coat the plugs with sealer, then install the plugs. Place the diaphragm spring and diaphragm in the body, lubricate the pump rod seal rubbing surface with grease, and hook the diaphragm pull rod on the lower link. Install the rocker arm return spring in the rocker arm. Install the valve gaskets, then press the valves in place with tool T56L-9350-A, detail 2. Stake each valve at four points. Hold the rocker arm in the up position, and place the cover on the pump body. Be sure the diaphragm extends evenly all around the cover. Use the diaphragm positioning tool T56L-9350-A, detail 4. Install the screws and tighten them evenly. Install the pulsator and the pulsator cover. Install the sediment bowl gasket, filter, and bowl.

(6) **INSTALLATION.** Coat both sides of a new gasket with sealer. Position the pump, and gasket, on the mounting flange. Hold the pump against the flange to compress the pump spring, then install and alternately tighten the pump mounting bolts to specifications. Connect the fuel inlet and outlet lines.

b. Combination Pumps.

Test and repair procedures for the combination fuel pump and vacuum booster (fig. 70) are presented here.

(1) **TESTS.** The fuel pump portion of the combination pump can be tested as previously outlined under, "a. Fuel Pump." Test the vacuum booster as follows:

Connect a vacuum gauge to the windshield wiper connection of the pump. Disconnect the pump to manifold line at the manifold and plug the line. Operate the engine at approximately 500 r.p.m., and observe the vacuum gauge. The pump should develop a vacuum of at least 10 inches of mercury.

(2) **REMOVAL.** Crank the engine to position the cam eccentric on the low side. Disconnect the fuel lines at the pump. Disconnect the vacuum lines at the vacuum booster. Remove the pump retaining screws, then remove the pump and gasket.

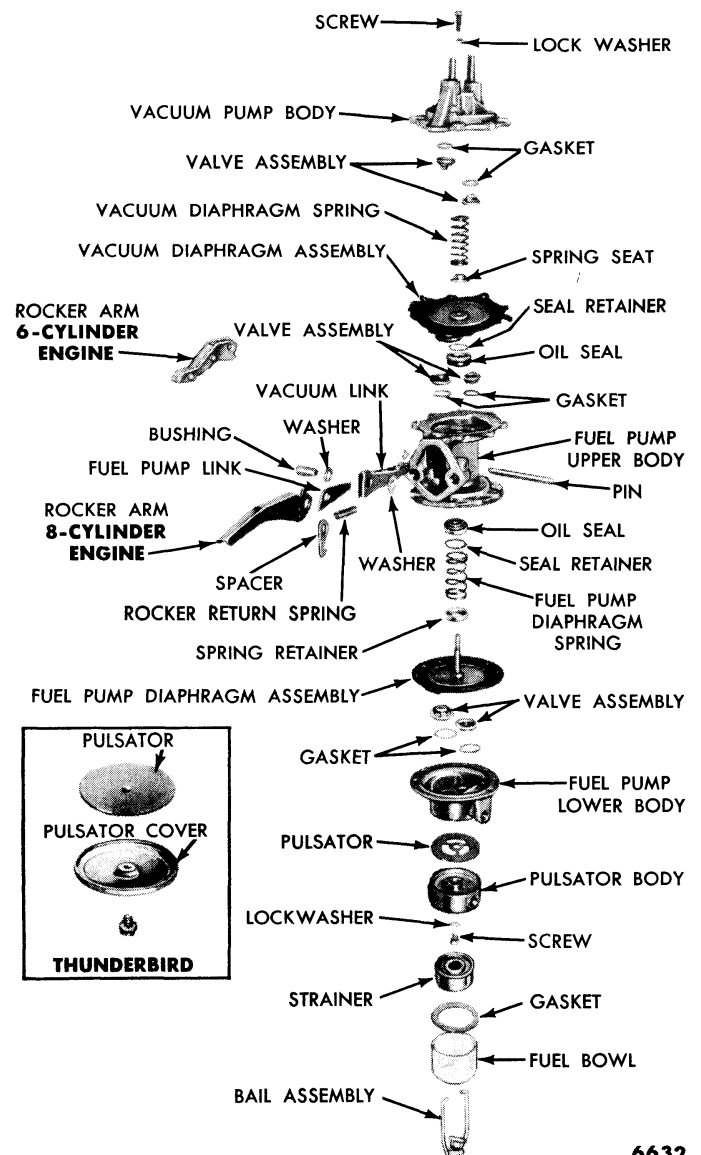

6632

Fig. 70—Combination Pump—Disassembled

(3) **DISASSEMBLY.** On all vehicles except the Thunderbird, remove the sediment bowl, filter, and gasket. Scribe a line to identify the pulsator chamber position. Remove the pulsator chamber and pulsator. Scribe a line on the fuel pump cover and body so its original position can be retained upon assembly. Hold the fuel pump cover against the pump body and remove the cover retaining screws. Remove the cover.

Hold the vacuum booster cover against the pump body, and remove the retaining screws. Allow the spring to push the cover away from the pump body, then remove the cover. Remove the spring and spring seat.

Remove the upset on the end of the rocker arm pin. Remove the retaining washer, then drive the pin out with detail 3, fig. 69 and work the fuel pump and booster links out of the diaphragm stems. Remove the vacuum booster diaphragm. Remove the fuel pump diaphragm,

spring seat, and spring. Remove the rocker arm and link assembly.

Remove the staking marks around the valves, and flip the valves out with a screw driver. Note the position of the inlet and outlet valves so the new valves can be installed in the same manner.

Remove the vacuum booster valve located in the pump body near the mounting pad. Scrape away the staking marks, and remove the other valve. Scrape away the staking marks, and remove the valves in the cover. Note the position of these valves so the new valves can be installed in the same manner.

Scrape away the staking marks, and remove the diaphragm rod oil seals and retainers.

(4) **CLEANING AND INSPECTION.** Clean the bowl, filter, pump body and the covers in solvent. Inspect the body, bowl, and covers for cracks or damage and replace if necessary. Inspect the staked areas around the valve and seal counterbores for high spots which may cause distortion of the new parts upon installation. Remove all high spots. Inspect the mounting flange for distortion. Replace the pump body or lap the distorted flange.

(5) **ASSEMBLY.** Install the diaphragm rod oil seals and seal retainers using tool T56L-9350-A, detail 1. Stake the seal retainers in place. Press the booster pump valves and gaskets in the pump body with detail 1, fig. 69. Stake the valves in place. Press in the valves and gaskets located inside the upper chamber cover with detail 1, fig. 69, and stake them in place.

Install the gaskets and valves in the fuel pump cover with detail 2, fig. 69, and stake them in place.

Place the fuel pump link (short link), with the hook up, inside the return spring retainer spacer. Place this assembly inside the vacuum pump link (long link). Place all these parts inside the rocker arm, and install the bushing. On the 6-cylinder pump, the cam contact surface of the rocker arm faces down. On the 8-cylinder pump, it faces up.

Install a thin washer, then a thick washer on each end of the bushing. Place the rocker arm return spring over the boss in the pump body. Place the rocker arm and link assembly in the pump body, and insert the long tapered drift, detail 3, fig. 69, in place of the rocker arm pin. Install the rocker arm pin by pushing the drift out with the pin. Place the retaining washer on the end of the pin, then peen the pin.

Lubricate the fuel pump diaphragm rod with grease. Assemble the spring seat (cup side toward the spring)

and spring on the fuel pump diaphragm rod. Insert the rod through the fuel pump oil seal, and hook the rod slot over the short link.

Lubricate the booster diaphragm rod with grease. Insert the booster diaphragm rod through the oil seal, and hook the slot in the rod in the long link. Install the spring seat with the cup side toward the diaphragm. Install the spring and the cover. Hold the cover tight against the diaphragm and pump body, and install the cover retaining screws. Make sure the diaphragm extends evenly around the edge of the cover. Use the diaphragm positioning tool T56L-9350-A, detail 4. Tighten the screws securely before releasing the cover.

Place the fuel pump cover on the diaphragm, aligning the scribed line on the cover with the line on the pump body. Compress the spring with the rocker arm, and install the cover retaining screws. Be sure the diaphragm extends evenly all around the edge of the cover. Use the diaphragm positioning tool. Tighten the screws securely, then release the rocker arm. Remove the diaphragm positioning tool.

Install the pulsator diaphragm and the pulsator chamber. Install the sediment bowl gasket, filter, and bowl. Rotate the bowl against the gasket before tightening the bail nut to make sure the bowl seats evenly against the gasket.

(6) **INSTALLATION.** Apply sealer to both sides of a new gasket. Position the gasket on the pump flange, and hold the pump in position against the mounting pad. Make sure the rocker arm is riding on the camshaft eccentric. Press the pump tight against the pad, install the retaining bolts, and alternately tighten them to 23-28 foot-pounds torque. Connect the vacuum lines and the fuel lines.

c. Fuel Filter—Thunderbird.

The fuel filter is located in the fuel line between the fuel pump and the carburetor.

(1) **REMOVAL.** Unscrew the bail nut at the lower section of the filter body. Remove the bowl. Remove and discard the filter element.

(2) **CLEANING AND INSPECTION.** Clean the bowl in solvent. Inspect the gasket and replace if necessary.

(3) **INSTALLATION.** Place the gasket over the filter assembly. Place the gasket and filter in the recess in the body. Install the glass bowl. Tighten the bail screw using normal thumb pressure.

9. FUEL TANKS AND LINES

The fuel tank, mounted on the underside of the rear compartment floor pan, is held in position by two metal straps. The tank to fuel pump line is fastened to the

frame left-hand side rail on 8-cylinder cars and to the frame right-hand side rail on 6-cylinder cars (fig. 71 and 72).

a. Fuel Tank Replacement.

Drain all the fuel from the tank before removing it from the vehicle.

(1) **REMOVAL.** Disconnect the fuel line at the tank. Remove the two nuts retaining the tank support straps to the body floor pan at the rear of the tank, remove the straps, and lower the tank. Disconnect the fuel gauge sending unit wire. Remove the sending unit.

(2) **INSTALLATION.** Be sure the fuel tank drain plug is installed in the new tank. Install the fuel gauge sending unit with a new gasket. Install the tank insulators. Connect the fuel gauge sending unit wire.

Hold the tank in position against the body floor pan. Hook the support straps to the retainers in the floor pan at the front of the tank. Position the straps over the studs, then install the nuts retaining the straps to the body floor pan at the rear of the tank.

Connect the fuel line to the tank. Fill the tank and check all connections for leaks.

b. Fuel Line Replacement.

The fuel line connecting the fuel pump to the tank is not serviced as an assembly. It must be made up from the $\frac{5}{16}$ inch (O.D.) line serviced in 25 foot rolls.

(1) **REMOVAL.** Drain the fuel from the tank. Disconnect the fuel line at the tank and at the flexible hose to the fuel pump. Remove the line from the holding clips along the frame. If the loom material on the old line is in good condition it can be re-used on the new line.

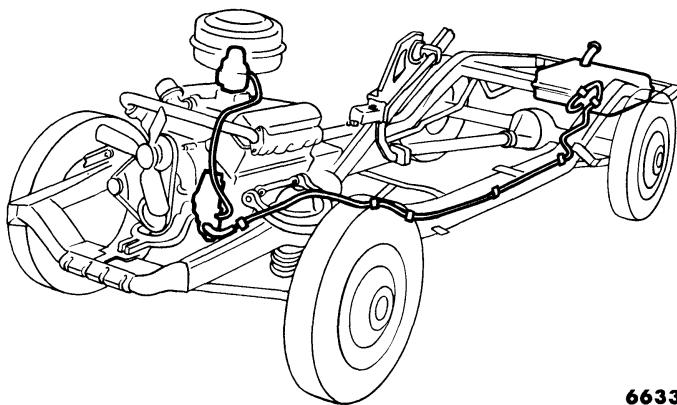

6633

Fig. 71—Fuel Line Installation—8-Cylinder

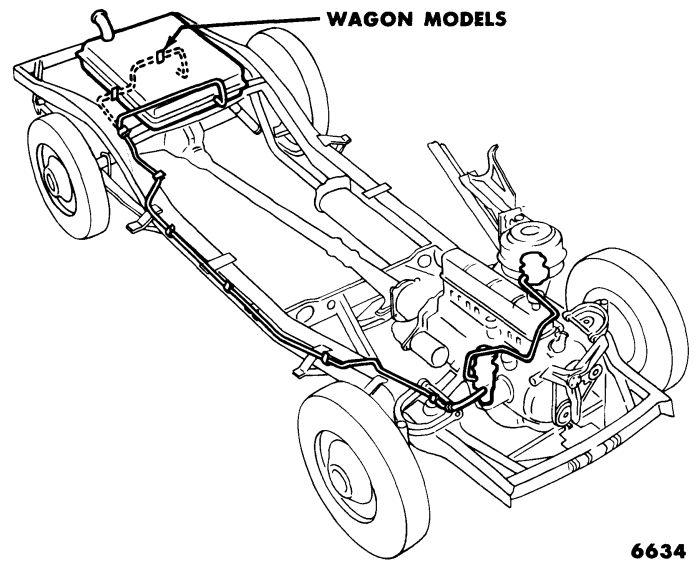

6634

Fig. 72—Fuel Line Installation—6-Cylinder

(2) **INSTALLATION.** Cut the new line to approximately the same length as the original, allowing extra length for flaring the ends of the line. Square the ends of the line with a file. Ream the inside edges of the line with the reamer blade on the tube cutter. Be sure that the metal chips are removed from the inside of the tube.

Position the protective loom on the new line. Place new connections on the line and flare the ends with the tool shown in fig. 73. Bend the line to conform with the contour of the original line. Position the line in the frame clips. Connect the line to the tank and the fuel pump flexible hose. Fill the tank and check the line and connections for leaks.

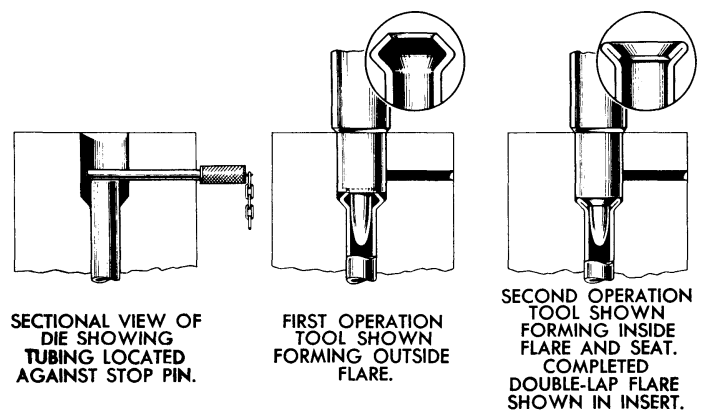

SECTIONAL VIEW OF DIE SHOWING TUBING LOCATED AGAINST STOP PIN.

FIRST OPERATION TOOL SHOWN FORMING OUTSIDE FLARE.

SECOND OPERATION TOOL SHOWN FORMING INSIDE FLARE AND SEAT. COMPLETED DOUBLE-LAP FLARE SHOWN IN INSERT.

2074

Fig. 73—Line Flaring Tool

10. FANS AND BELTS

The fan is mounted on a hub which is pressed on the water pump shaft. One belt drives the water pump, fan and generator.

a. Fans.

Three-bladed fans are used on the 6-cylinder engine

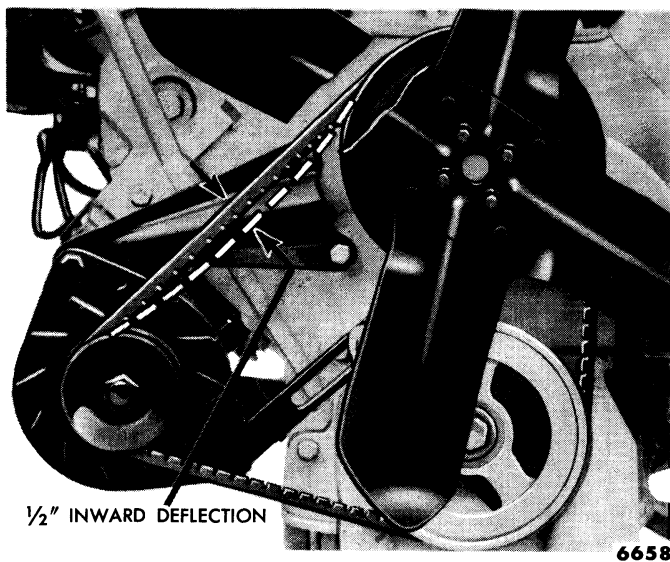

6658

Fig. 74—Fan Belt Deflection—8-Cylinder Engine—Typical

and four-bladed fans are used on the 8-cylinder engines. The fan is bolted to the hub by four cap screws and lock washers. The screws used to fasten the fan also retain the water pump-fan pulley. On 8-cylinder cars, a pulley to fan spacer is used.

(1) **FAN REPLACEMENT.** Loosen the generator link clamp screw and the two generator mounting screws. Move the generator toward the engine, then remove the fan belt. Remove the screws and lock washers retaining the fan, spacer (8-cylinder engine), and pulley to the hub. Remove the fan blades, spacer, and pulley.

To install the fan, hold the pulley and fan against the spacer and hub (8-cylinder engine). Install the lock washers and screws. Install the fan belt, then adjust the belt tension.

b. Belts.

Fan belts should be properly adjusted at all times. Loose belts cause improper generator, fan, and water pump operation. A belt that is too tight places a severe strain on water pump and generator bearings.

Adjustment of the power steering pump belt is cov-

a. Water Pump—6-Cylinder Engine.

A repair kit is available for service.

(1) **REMOVAL.** Drain the cooling system and disconnect the lower radiator hose and heater hose. Remove the fan belt and fan. Remove the three bolts re-

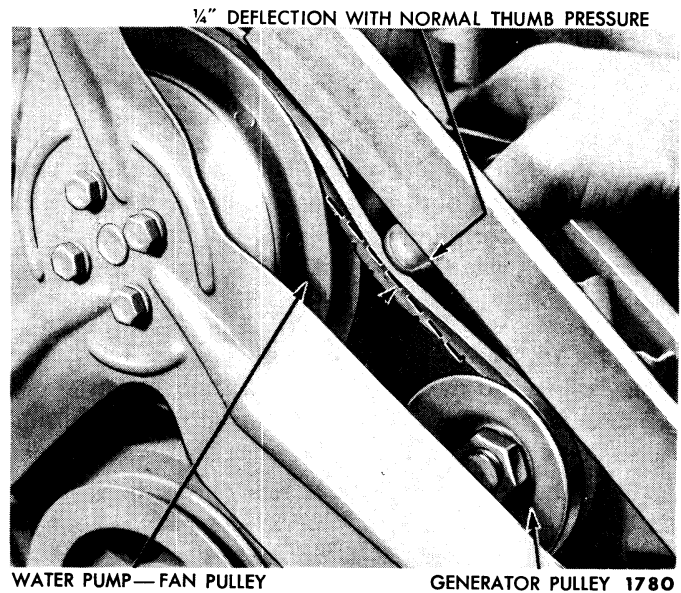

WATER PUMP—FAN PULLEY

GENERATOR PULLEY 1780

Fig. 75—Fan Belt Deflection—6-Cylinder Engine—Typical
ered under "Part Two—Chassis." Adjustment of the air conditioning compressor belt is covered in "Part Three—Electrical and Accessories."

(1) **ADJUSTMENT.** Loosen the generator mounting bolts and the generator link clamp bolt. Move the generator toward or away from the engine until the correct belt deflection under light thumb pressure, is obtained.

On 8-cylinder engines, the deflection should be $\frac{1}{2}$ inch when measured as shown in fig. 74. On 6-cylinder engines, the deflection should be $\frac{1}{4}$ inch when measured as shown in fig. 75. After the correct deflection is obtained, tighten the generator link clamp screw and the mounting bolts.

(2) **REPLACEMENT.** Loosen the generator mounting bolts and the generator link clamp bolt. Move the generator toward the engine. Remove the belt from the generator and crankshaft pulleys, and lift it over the fan.

Place the belt over the fan, and insert it in the water pump pulley, crankshaft pulley, and generator pulley grooves. Adjust the belt tension.

11. WATER PUMPS

Single water pumps are used on both the 6-cylinder and 8-cylinder engines. These pumps are equipped with a sealed bearing integral with the water pump shaft. The bearing requires no lubrication.

taining the pump to the block, then remove the pump and the gasket.

(2) **DISASSEMBLY.** Press the shaft out of the hub (fig. 76). Remove the snap ring retaining the bearing in the housing. Press the shaft out of the impeller and the pump body (fig. 77).

Press out the pump seal (fig. 78). Be sure the tool is not caught on the snap ring inside the pump housing. A disassembled view of the 6-cylinder pump is shown in fig. 79.

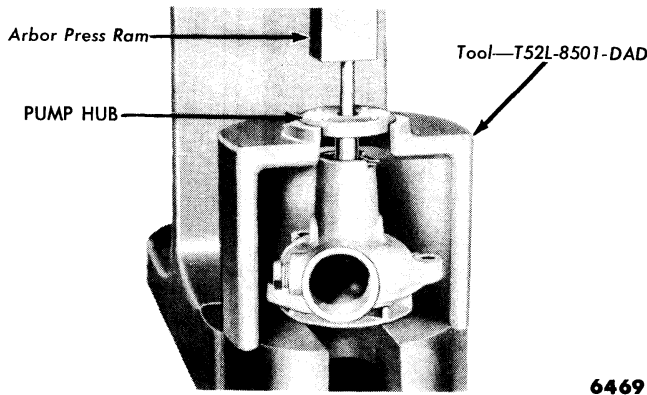

Fig. 76—Hub Removal

6469

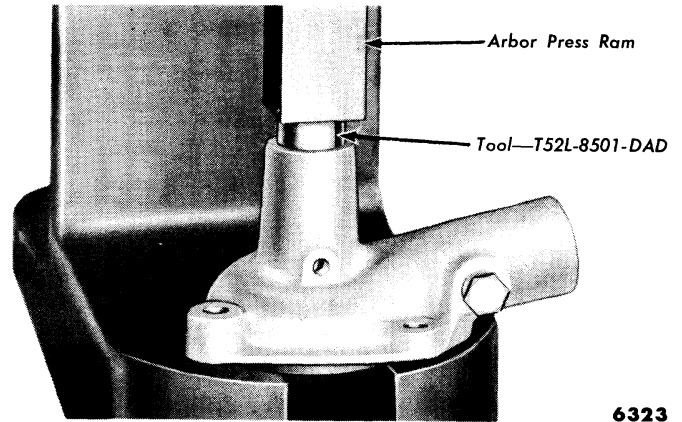

Fig. 78—Pressing Out Seal—Typical

6323

(3) **ASSEMBLY.** Clean all gasket material from the mounting face of the pump. Install a new seal in the pump housing as shown in fig. 80. Coat the seal with a light coating of waterproof sealer. Use the seal installing tool marked 8501-DD-17.

NOTE: *When installing a new shaft and bearing assembly, install a new slinger on the shaft in the same relative position as the slinger on the old shaft, using tool T-52L-8501-DAD, detail 18.*

Coat the bearing outer diameter lightly with grease, and press the shaft and bearing into the pump housing applying pressure to the outer shell of the bearing.

Inspect the seal rubbing face of the impeller for grooves. Replace the impeller if it is worn or damaged.

Coat the seal rubbing face of the impeller lightly with grease. Press the shaft into the impeller as shown in fig. 81.

CAUTION: *Press the shaft into the impeller until the pump housing lightly touches the face of the insert ring. If excessive pressure is exerted on the shaft after the rear face of the housing contacts the insert ring, the pump bearing will be damaged.*

The impeller to pump body clearance should be 0.020-0.030 inch after pressing on the impeller.

Tighten the set screw in the bottom of the fixture plate until the screw touches the end of the shaft. Do not lift the pump body off the fixture plate.

Install the snap ring in the housing. Press the water pump hub on the shaft as shown in fig. 82. Be sure to hold the dimension shown in fig. 82.

(4) **INSTALLATION.** Coat a new gasket on both sides with sealer, then install the pump body and gasket on the block. Install the retaining screws, and tighten them to 23-28 foot-pounds torque. Install the pulley and fan. Install the belt and adjust the belt tension. Connect the radiator hose and heater hose, then fill the cooling system.

b. Water Pump—8-Cylinder Engine.

A repair kit is available for service.

(1) **REMOVAL.** On Thunderbirds, remove the engine left-hand splash shield.

Drain the cooling system. Disconnect the lower radiator hose and heater hose. Remove the fan belt, fan, fan spacer, and pulley.

On Thunderbirds, remove the generator support bracket bolt at the water pump housing and the bolt at the generator, then move the bracket out of the way. Remove the remaining bolts retaining the water pump

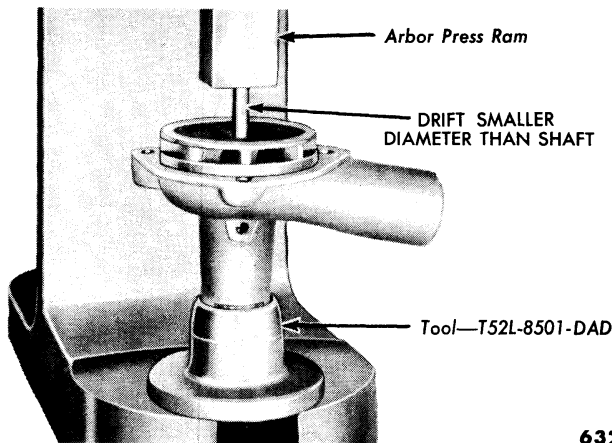

Fig. 77—Pressing Out Shaft—Typical

6322

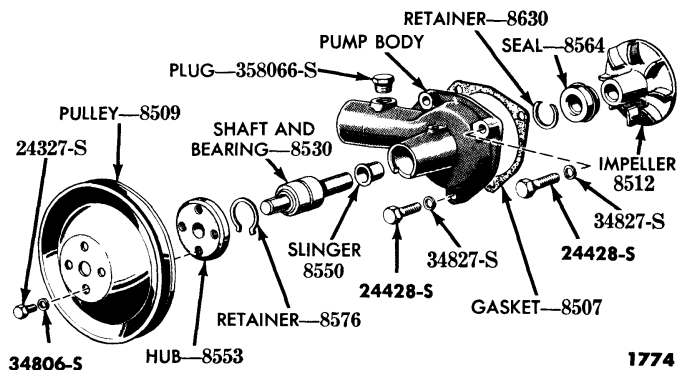

Fig. 79—6-Cylinder Water Pump—Disassembled

1774

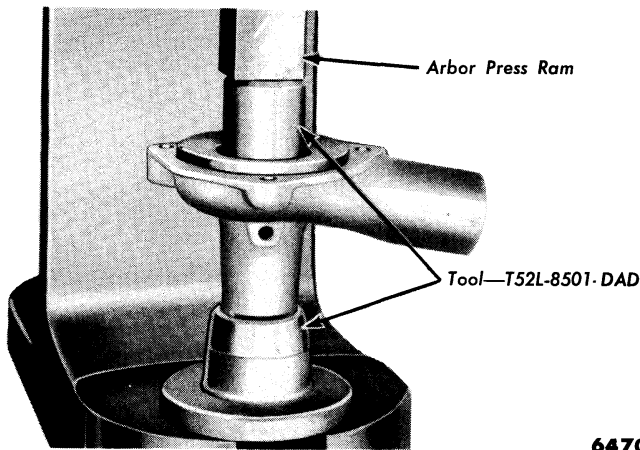

Fig. 80—Seal Installation—Typical

6470

assembly and timing pointer. Remove the water pump assembly.

On all other vehicles, remove the four bolts retaining

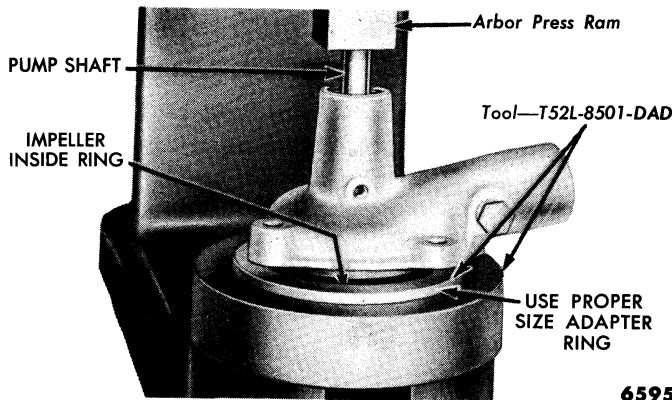

Fig. 81—Pressing Shaft Into Impeller—Typical

6595

the pump to the cover, remove the pump, and the timing pointer.

(2) **DISASSEMBLY.** Pull the hub off the shaft, using

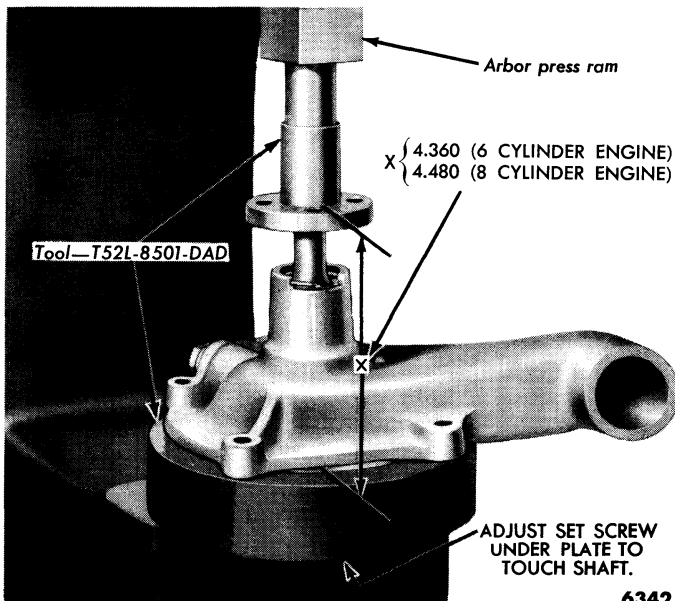

Fig. 82—Hub Installation—Typical

6342

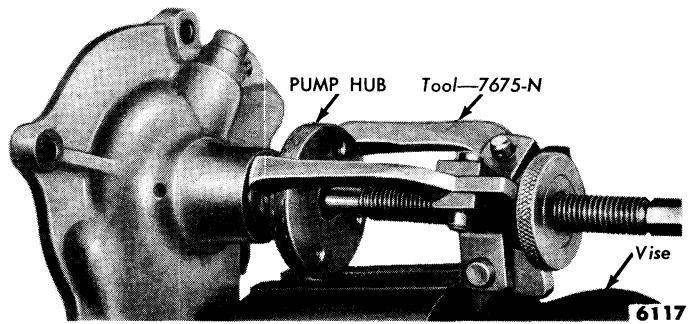

Fig. 83—Hub Removal

6117

a 3 or 4 jaw-type gear puller (fig. 83). Remove the snap ring retaining the bearing in the housing. Press the shaft out of the impeller and the pump body (fig. 77).

Press out the pump seal (fig. 78). Be sure the tool is not caught on the snap ring inside the pump housing.

A disassembled view of the water pump is shown in fig. 84.

(3) **ASSEMBLY.** Clean off any gasket material on the mounting face of the pump and the cylinder front cover. Coat a new seal with a light coating of waterproof sealer. Install the seal in the pump housing as shown in fig. 85.

Coat the bearing outer diameter lightly with grease, and press the shaft and bearing into the pump housing, applying pressure to the outer shell of the bearing.

Inspect the seal rubbing face of the impeller for grooves. Replace the impeller if it is worn or damaged. Coat the seal rubbing face of the impeller lightly with grease. Press the shaft into the impeller as shown in fig. 86.

CAUTION: Press the shaft into the impeller until the pump housing lightly touches the face of the insert ring. If excessive pressure is exerted on the shaft after the rear face of the housing contacts the insert ring, the pump bearing will be damaged. Impeller to pump housing clearance is 0.030-0.040 inch.

Tighten the set screw in the bottom of the fixture plate until the screw touches the end of the shaft. Do not lift the pump body off the fixture plate.

Install the snap ring in the housing. Press the fan hub on the shaft as shown in fig. 82. Be sure to hold the dimension shown in fig. 82.

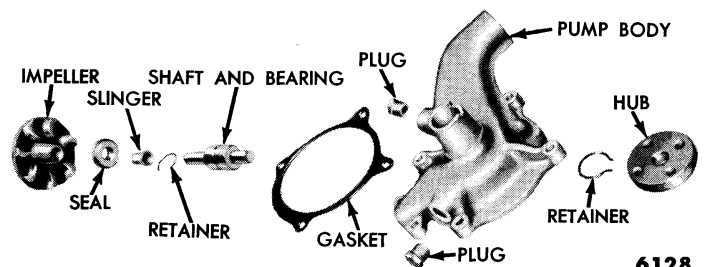

Fig. 84—Water Pump—8-Cylinder Engine

6128

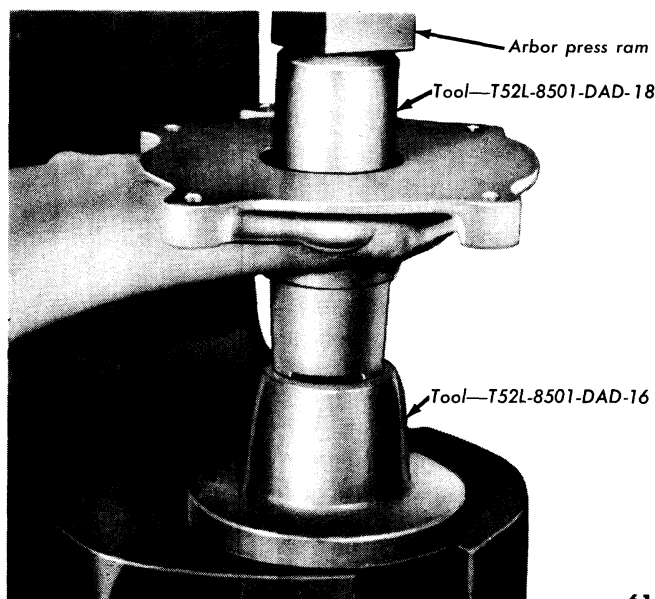

Fig. 85—Seal Installation

(4) **INSTALLATION.** Position a new gasket, coated on both sides with sealer, on the cylinder front cover, then install the pump body on the cover. Position the timing pointer at the two lower mounting holes with the point to the right side of the engine.

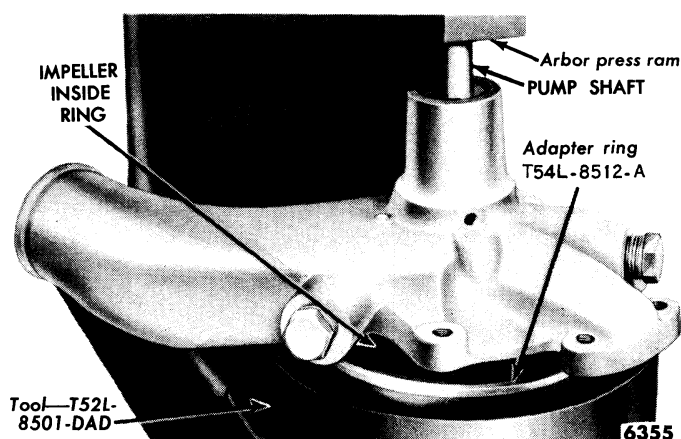

Fig. 86—Pressing Shaft into Impeller

On the Thunderbird, position the generator support bracket on the cylinder front cover.

Install the retaining bolts, and tighten them to 12-15 foot-pounds torque. Install the pulley, spacer, and fan. Install the belt and adjust the belt tension. Connect the radiator hose and heater hose, then fill the cooling system.

On Thunderbirds, install the engine left-hand splash shield.

Run the engine until normal operating temperature has been reached, then check for leaks.

12. RADIATOR, HOSE, AND THERMOSTAT

The cooling system of the passenger car is pressurized at approximately 13 p.s.i.

CAUTION: Use care when removing the radiator cap, to avoid injury from escaping steam or hot water.

a. Care of Cooling System.

Although the cooling system controls the operating temperature of the engine, late ignition timing, a lean fuel mixture, or improper or insufficient lubricating oil in the crankcase may cause the engine to overheat. Refer to "Trouble Shooting" to determine the various causes of inefficient cooling.

(1) **CLEANING COOLING SYSTEM.** To remove rust, sludge, and other foreign material from the cooling system, use either Cooling System Cleanser (1A-19527-A) or Heavy Duty Cleanser (1A-19527-B) in severe cases. Removal of such material restores cooling efficiency and avoids overheating.

In severe cases where cleaning solvents will not properly clean the cooling system for efficient operation, it will be necessary to use the pressure flushing method.

Various types of flushing equipment are available. If pressure flushing is used, make sure the cylinder head

bolts are properly tightened to prevent possible water leakage into the cylinders.

NOTE: Always remove the thermostat prior to pressure flushing.

A pulsating or reversed direction of flushing water flow will loosen sediment more quickly than a steady flow in the normal direction of coolant flow.

(2) **RUST INHIBITOR.** Use Rust Inhibitor (8A-19546-C) after the cooling system has been cleaned, to prevent additional corrosion or rust. Rust inhibitor does not remove rust nor dissolve rust. It is a preventive only and not a cleaner.

All anti-freeze sold by reputable manufacturers contains an anti-rust additive. Therefore, the addition of rust inhibitor, when anti-freeze is used, will not be necessary.

b. Drain Cooling System.

To drain the radiator, open the drain cock located at the bottom of the radiator. The cylinder block of the 8-cylinder engine is drained by opening the drain cocks located at both sides of the cylinder block. The 6-cylinder engine has one drain cock located at the left rear of the cylinder block.

Install the radiator support bolts. Connect the radiator hoses. Fill the cooling system. Warm the engine to normal operating temperature, then check for leaks.

(3) **REMOVAL—THUNDERBIRD.** Raise the front of the vehicle and position safety stands. Drain the cooling system. Remove the fan lower shroud. Remove the radiator upper and lower hoses. Remove the radiator support bolts and remove the radiator and upper shroud as an assembly.

(4) **INSTALLATION—THUNDERBIRD.** Install the fan upper shroud on the radiator but do not tighten the bolts. Position the radiator and shroud in the vehicle. Install and tighten all radiator mounting bolts. Position the fan upper shroud so it is concentric with the fan (approximately $\frac{3}{4}$ inch clearance from the fan blade tip to the shroud), then tighten all upper shroud retaining bolts. Raise the front of the vehicle. Install the fan lower shroud. Install the radiator lower hose. Lower the front of the vehicle. Install the radiator upper hose. Fill the radiator. Run the engine until normal operating temperature has been reached, then check for coolant leaks and proper coolant level.

d. Radiator Hose.

Radiator hoses should be replaced whenever they become cracked or soggy.

(1) **REMOVAL.** Drain the radiator, then loosen the clamps at each end of the hose. Slide the hose off the radiator connection and the water outlet connection (upper hose) or the water pump connection (lower hose).

(2) **INSTALLATION.** Position the clamps on each end of the new hose. Slide the hose on the connections, tighten the clamps firmly. Make sure the clamps are beyond the bead on the connections. Fill the radiator with coolant, run the engine for several minutes, and check the hose and connections for leaks.

e. Thermostat.

All passenger cars are equipped with a single, spring and cartridge-type thermostat, mounted inside the water outlet elbow.

The standard thermostat for use with any anti-freeze or water is 157°-162° F. When using water or permanent type anti-freeze, the standard high temperature 177°-182° F. thermostat can be used.

NOTE: Do not attempt to repair the thermostat. It should be replaced if it is not operating properly.

(1) **REMOVAL.** Drain the cooling system. Disconnect the radiator hose at the outlet elbow. Remove the

elbow, thermostat, and gasket (6-cylinder). Remove the screws retaining the water outlet to the intake manifold (8-cylinder). Remove the screws retaining the water bypass to the water pump. Remove the elbow, thermostat, and gasket with the bypass and bypass hose still attached to the elbow.

(2) **THERMOSTAT TEST.** Insert a piece of 0.003-inch feeler stock $\frac{1}{8}$ inch under the nose of the butterfly valve. Suspend the thermostat, by the feeler stock, in a large container of water so that it is completely submerged, and 1 to 2 inches from the bottom.

NOTE: Suspension of the thermostat in this manner will give an accurate indication when the valve starts to open. The thermostat will drop off the feeler stock. If the thermostat will not stay on the feeler stock when it is first inserted, discard the thermostat.

Suspend a thermometer in the water so that the bulb is at the same level as the thermostat element. Heat the water slowly, and stir it frequently to normalize the temperature. If the valve opens at a temperature of more than 5° below the start-to-open specification, or if the valve does not open at a temperature of more than 5° above the start-to-open specification, the thermostat should be replaced.

(3) **INSTALLATION.** Coat a new water outlet elbow gasket with sealer, then position the gasket on the intake manifold opening (8-cylinder). Place the gasket on the cylinder head opening (6-cylinder).

NOTE: The water outlet gasket must be positioned on the manifold, or head, before the thermostat is installed. If the gasket is placed between the thermostat and the elbow, damage to the thermostat and leaks may result.

Install the thermostat in the cylinder head, or manifold, opening with the word "TOP" toward the top of the engine and the valve end of the thermostat facing outward.

NOTE: If the thermostat is improperly positioned, it can cause a retarded flow of coolant.

Position the outlet elbow against the manifold, or head, and the water bypass against the water pump, then install a new bypass gasket that has been coated with sealer (8-cylinder). Install the retaining screws, and tighten them to 12-15 foot pounds torque (8-cylinder) or 23-28 foot-pounds torque (6-cylinder).

Connect the radiator hose. Fill the cooling system and check for leaks and proper coolant level after the engine has reached normal operating temperature.

Part TWO

CHASSIS

Chapter

I

Clutch, Transmissions, and Gear Shift Linkage

Section	Page
1 Trouble Shooting	117
2 Clutch	119
3 Flywheel Housing Alignment	123
4 Transmission Cleaning and Inspection	124
5 Conventional 3-Speed Transmission	125
6 Overdrive Transmission	129
7 Gear Shift Linkage	138

The same basic clutch and conventional 3-speed transmission are used, as standard equipment, in all cars. An overdrive transmission is available, as optional equipment, for all cars. However, because of certain vehicle design differences, some Thunderbird clutch

and transmission service procedures differ from the procedures used for the same units in the other cars.

The gear shift linkage in the Thunderbird differs in design from the linkage in the other cars.

1. TROUBLE SHOOTING

a. Clutch.

Clutch troubles can often be corrected without removing the clutch from the car.

(1) **NOISY CLUTCH.** To locate the cause of noisy clutch operation, the following checks should be made.

(a) **NOISY WITH ENGINE OFF.** If noise occurs when the pedal is moved up and down with the engine off, the noise is probably in the clutch linkage or the pressure plate and cover assembly. If the linkage needs lubrication, use engine oil S.A.E. 10. If the pressure plate lugs need lubrication, use Lubriplate or equivalent (fig. 8).

Check the retracting spring installation. The spring should be installed with the long straight section of the spring toward the front of the car. If installed backwards it will rub against the steering gear housing.

(b) **NOISY WHEN FREE TRAVEL IS TAKEN OUT.** With the engine running, depress the clutch pedal until all free travel is taken out. This brings the release bearing in contact with the release fingers and causes the bearing to spin. If noise occurs at this point, the clutch release bearing has probably failed and must be replaced. To find the cause of the release bearing failure, follow the procedure given under (2) **INSPECTION** in the clutch section.

(c) **NOISY WHEN PEDAL IS THREE-QUARTERS TO FULLY DEPRESSED.** If noise occurs only when the pedal is three-quarters to fully depressed with the engine running, the probable cause is misalignment between the engine and flywheel housing or a loose or worn pilot bearing or bushing. Alignment procedure is given in Section 3.

(2) **CLUTCH DOES NOT ENGAGE OR DISENGAGE PROPERLY.** If the clutch slips, chatters, or grabs, check and, if necessary, adjust the clutch pedal free travel.

Inspect the clutch facings for oil or grease. This condition may indicate possible lubricant leaks that should be found and corrected. The leak may be from the release bearing, pilot bearing, release lever pivot or transmission.

Check for loose, worn, or damaged parts, and replace anything that is not operating properly.

b. Transmissions.

Always check the possibility that trouble may exist in the clutch, drive shaft, universal joints, or rear axle before removing the transmission from the car for inspection.

(1) **NOISY TRANSMISSION.** A limited amount of transmission gear noise is normal. However, excessive noise may be caused by misalignment due to loose mounting bolts, flywheel housing misalignment, dirt or metal chips in the lubricant, or not enough lubricant in the transmission.

Tighten loose mounting bolts and nuts to the specified torque. Check the condition and the level of the lubricant. Drain and refill, if necessary, or add lubricant if the level is low.

Transmission noise may be caused by worn or damaged parts. Replace the parts as required to correct the noise, or overhaul the transmission assembly.

(2) **TRANSMISSION SHIFTS HARD.** Check the clutch linkage adjustment, and adjust or repair if necessary.

Inspect the transmission linkage for binding caused by bent or worn parts. Replace or repair all worn or damaged parts.

Hard shifting may be caused by improper lubricant in the transmission. Drain and refill, if necessary, with the correct type of lubricant.

(3) **TRANSMISSION JUMPS OUT OF GEAR.** Improper shifting may cause the transmission to jump out of gear. Be sure the gears are completely engaged before releasing the clutch pedal.

Check the transmission linkage for wear and bent parts, then check the adjustment.

Check for excessive end play caused by wear in the shift forks, sliding gear fork grooves, thrust washers, output shaft or countershaft bearings, or clutch pilot bushing. Check for misalignment or excessive clearance between the sliding gear and the output shaft.

Check the operation of the gear shift housing assembly, and replace any broken or damaged parts.

(4) **FLUID LEAKAGE.** Fluid leaks may be caused by overfilling the transmission or by using a lubricant that foams and expands while the car is in operation. Check the lubricant, and drain and refill with the correct type of lubricant if necessary.

Loose gear shift housing cap screws may allow the lubricant to escape between the housing and the transmission case. Tighten the screws if they are loose.

Check the condition of the bearing retainers and gaskets, and replace any that are worn or damaged.

c. Overdrive Unit.

Most overdrive troubles are caused by an improperly operating control circuit. The overdrive operating principles should be thoroughly understood before attempting to follow the trouble-shooting procedures.

(1) **KICKDOWN SWITCH CUTS OUT ENGINE.** If the engine stops when the kickdown shift is operated, the switch or the orange solenoid wire may be defective.

Disconnect the orange solenoid wire at the bullet connector, then press the kickdown switch. If the engine continues to run after operating the switch, repair the insulation on the orange solenoid wire or replace the solenoid. If the engine stops, replace the kickdown switch or the wire between the switch and the solenoid.

(2) **OVERDRIVE DOES NOT KICK DOWN.** A failure in the solenoid assembly, the kickdown switch, or the circuit wiring will prevent the overdrive kicking down.

With the engine running, disconnect the blue-orange wire from the solenoid, connect a grounded jumper wire to the blue-orange wire leading to the kickdown switch, and press the kickdown switch. If the engine now stops, repair the ignition grounding contacts in the solenoid or replace the solenoid.

If the engine will not stop, connect the grounded jumper to the ignition terminal on the kickdown switch. If the engine now stops, repair or replace the wire from the kickdown switch to the solenoid, or replace the switch. If the engine continues to run, repair or replace the wire from the kickdown switch to the ignition coil.

(3) **OVERDRIVE DOES NOT DISENGAGE.** If the overdrive does not disengage, the cause of the trouble may be either mechanical or electrical.

Place the transmission in neutral and the ignition switch at OFF, then try to roll the car backward manually. Do not force the car backward if it does not roll. Remove the solenoid and check the pawl action. If the solenoid can be removed without rotating it $\frac{1}{4}$ turn, it indicates improper installation. The ball on the end of the solenoid must be engaged in a slot in the pawl. If the solenoid is properly installed, attempt to withdraw the pawl from engagement. If the pawl will not move freely, the unit is damaged internally and must be repaired or replaced. If the pawl moves freely, the solenoid must be repaired or replaced.

If the car can be rolled backward, turn the ignition switch on and off. If the relay and solenoid click, the trouble is in the control circuit. Check the control circuit, step by step, by disconnecting the various units of the circuit in the following order: Governor, kickdown switch, and relay. If the relay and solenoid do not click when any particular unit is removed from the circuit (ignition on) repair or replace that unit.

If the car can be rolled backward and the relay and solenoid do not click when the ignition switch is turned on and off, check the circuit wiring for an intermittent short circuit. If the wiring is in good condition, and the governor cuts out at less than 21 m.p.h. it must be adjusted or replaced.

(4) **OVERDRIVE DOES NOT ENGAGE.** This symptom is usually caused by a failure of the electric control system. An improperly adjusted lock-out control cable could also cause it.

Check the fuse and replace it if necessary. Be sure the overdrive control handle is pushed in and the ignition switch is ON. Check the control circuit by grounding the units in the following order: Governor, kickdown switch, and relay. If the relay and solenoid operate when any particular unit is grounded, repair or replace that unit.

Check the adjustment of the control cable which connects the overdrive control knob to the shift rail lever on the overdrive housing. If the shift rail lever is not moved against the rear stop when the control handle is pushed in, the shift rail may block the pawl from moving into engagement when the solenoid is

actuated. If the shift rail lever is not against the stop, loosen the cable clamp, move the lever firmly against the stop, then tighten the clamp.

NOTE: *Be sure that there is 1/4 inch clearance between the control handle shank and the dash bracket when the control handle is pushed all the way in.*

d. Gear Shift Linkage.

If the gear shift lever binds or feels excessively loose when shifting gears, check the gear shift linkage for worn, bent, or improperly adjusted parts.

2. CLUTCH

A semi-centrifugal, single dry-plate, cushion-disc type clutch is used on all cars except those equipped with Fordomatic. The clutch is available in 9½-inch, 10-inch, and 11-inch sizes.

a. Construction and Operation.

The clutch disc assembly (fig. 1) consists of the hub, disc, facings, and damper springs.

The hub, on which the clutch disc is mounted, is splined to the transmission input shaft. The two facings are riveted to the disc.

When the clutch is engaged, the forward facing contacts the engine flywheel, and the rear facing contacts the clutch pressure plate.

The clutch pressure plate and cover assembly (fig. 1) contains the pressure plate, cover, springs, and release

fingers. The three release fingers are mounted on needle roller bearings and are attached to the clutch cover.

On all 1956 clutches, the outer ends of the release fingers are weighted. As engine speed increases, centrifugal force on the weighted finger ends causes the fingers to exert increasing pressure against the clutch plate. The faster the clutch revolves, the greater the pressure against the clutch plate. This greater pressure increases the clamping action of the plate on the clutch disc, which increases the torque-transmitting ability of the clutch.

The clutch release bearing assembly (fig. 1) is a prelubricated, sealed ball bearing and is pressed onto the bearing hub. The bearing hub is attached to the fork end of the clutch release lever by two spring clips. The clutch release bearing assembly does not require periodic lubrication.

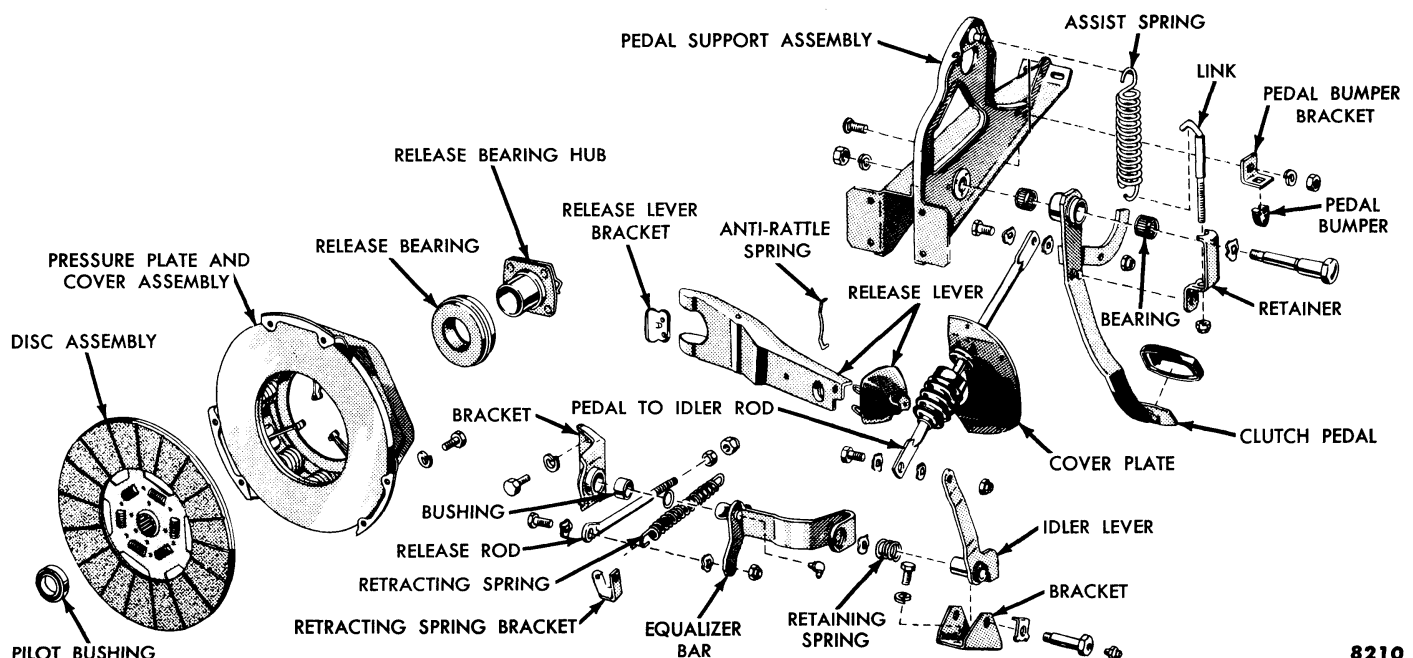

Fig. 1—Conventional Clutch and Linkage

An oil-impregnated bronze bushing is installed in the engine crankshaft and is used as a pilot for the transmission input shaft.

The clutch pedal is suspended from a bracket which is attached to the underside of the instrument panel and the dash panel. A rod connects the pedal to an idler lever assembly which is connected to the clutch release equalizer bar. The equalizer bar and the idler lever assembly are mounted on a shaft which is supported by a bracket on the frame side member. The right-hand end of the equalizer bar is supported by a bracket mounted on the flywheel housing.

The clutch pedal release rod is attached to the right-hand end of the equalizer bar and to the outer end of the clutch release lever assembly. The rear end of the release rod is threaded and is equipped with an adjusting nut for the clutch pedal free travel adjustment.

b. Clutch Pedal Adjustment.

A clutch pedal adjustment should be made whenever the clutch does not disengage or engage properly, or when new clutch parts are installed. Both the total travel and the free travel of the pedal should be adjusted.

To adjust the clutch pedal total travel, measure the total travel of the pedal (fig. 2). If the travel is less than $6\frac{3}{8}$ inches or more than $6\frac{5}{8}$ inches, move the clutch pedal bumper and the bracket (fig. 1) up or down until the travel is within these limits.

Adjust the assist spring link (fig. 1) to give the assist spring a length of $6\frac{5}{8}$ inches, when the clutch is fully released.

After the correct total travel has been established, check the pedal free travel. Depress the clutch pedal by hand, then measure the distance the clutch pedal travels before the clutch begins to disengage. The free travel (fig. 2) should be $1\frac{1}{8}$ - $1\frac{3}{8}$ inches.

To adjust the pedal free travel, loosen the lock nut on the clutch pedal release rod (fig. 1) and turn the ad-

justing nut. When the adjusting nut is turned clockwise, free travel is increased. When the adjusting nut is turned counterclockwise, free travel is reduced.

It is very important that the clutch pedal free travel be at least $1\frac{1}{8}$ inches. On the 1956 clutches, the centrifugal weights at high speed will move the release fingers closer to the release bearing and reduce the pedal free travel by as much as $\frac{3}{4}$ of an inch.

On all clutches, the pedal free travel should be checked while the engine is running at approximately 3000 r.p.m. This check can be made while the car is standing and transmission is in neutral. The pedal free travel under these conditions must be at least $\frac{1}{2}$ inch. Readjust if necessary to obtain at least $\frac{1}{2}$ inch pedal free travel with the engine running approximately 3000 r.p.m.

NOTE: *If clutch trouble is still present after the pedal free travel has been correctly adjusted, remove the clutch from the car for repairs or replacement.*

c. Clutch Overhaul.

A clutch overhaul includes the removal, inspection, replacement (if necessary), and installation of the various sub-assemblies and parts in the clutch.

(1) **REMOVAL OF SUB-ASSEMBLIES.** The removal procedures for the Thunderbird differ from those for all other models.

(a) **CONVENTIONAL CLUTCH.** Remove the transmission from the car. Slide the clutch release bearing and hub assembly off the end of the release lever assembly. Disconnect the clutch pedal release lever assembly. Disconnect the clutch pedal release rod from the release lever (fig. 1).

Remove the clutch release equalizer bar bracket from the flywheel and clutch housing. Remove the split bronze bushing from the bracket, then remove the flywheel housing from the engine.

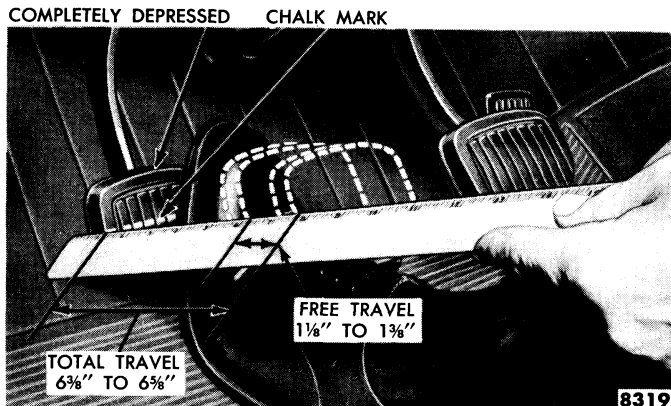

Fig. 2—Clutch Pedal Travel

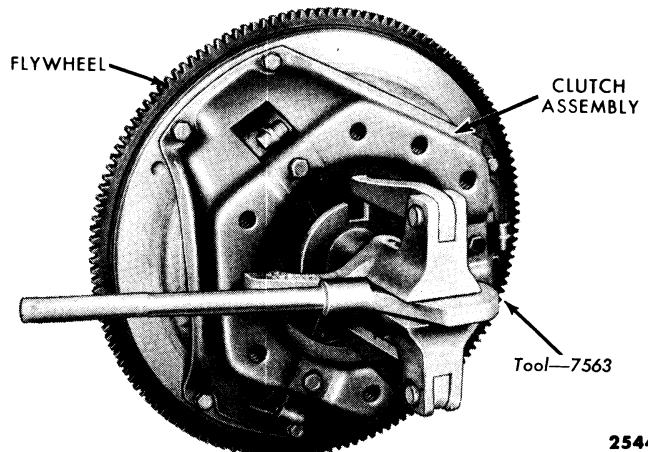

Fig. 3—Releasing Clutch Spring Tension

Mark the pressure plate cover so it can be replaced in the same position. Install the tool shown in fig. 3, and release the clutch pressure plate spring tension. If the tool is not available, release the spring tension by backing off the attaching bolts slowly and evenly.

(b) **THUNDERBIRD CLUTCH.** Drain the transmission, remove the drive shaft, and disconnect the shift rods at the transmission. Place a jack under the transmission. Disconnect the transmission from the flywheel housing, and move the transmission toward the rear of the car so that the clutch parts can be removed from the flywheel housing.

Slide the clutch release bearing and hub assembly off the end of the release lever assembly. Remove the pressure plate and cover assembly and the clutch disc from the engine flywheel.

Remove the bolts that attach the flywheel housing to the engine, then lower the flywheel housing.

NOTE: *The flywheel housing must be turned upside down to remove it.*

(2) **INSPECTION.** The clutch is designed for a long service life. When a premature failure occurs, it is important that the cause of the failure be found in order to make a permanent repair.

(a) **RELEASE BEARING.** With the release bearing still on the hub, wipe the oil and dirt off the bearing. Do not clean the bearing with solvent as it is prelubricated. Hold the inner race, apply pressure on the outer race, and rotate. If roughness or noise is observed, the bearing must be replaced.

The most common cause of release bearing failure is improper pedal adjustment. If there is not enough free travel in the clutch linkage, the release bearing is always touching the release fingers and is spinning whenever the engine is running. If the release bearing was not properly installed on the hub, a premature failure will occur. To seat the bearing squarely and fully on the hub, use the tool shown in fig. 4.

Release bearing failure can be caused by the release lever contact points being out of plane. Check the wear on the release bearing hub where the release lever contacts it. The wear should be approximately equal. If one side shows more wear than the other, the release lever is bent or is not centering on the bracket on the flywheel housing. The release lever has a groove 0.050-0.070 inches deep at the pivot point.

Misalignment between the engine and transmission can cause release bearing failure. Other symptoms of misalignment are: excessive transmission gear wear; transmission jumping out of gear, especially high; vibration in the drive line; excessive wear in the pilot bushing.

(b) **PRESSURE PLATE AND COVER ASSEMBLY.** Inspect

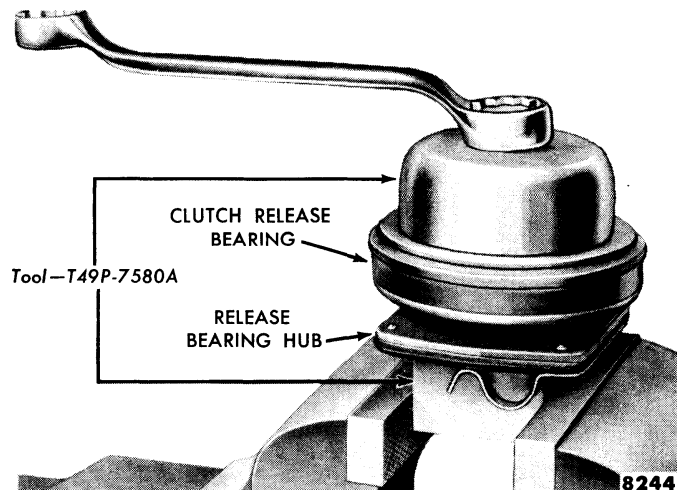

Fig. 4—Clutch Release Bearing Installation

the surface of the pressure plate for burn marks, scores, or ridges. Generally, pressure plate resurfacing is not recommended. However, minor burn marks, scores, or ridges may be removed. Care must be taken, during the resurfacing process, not to destroy the flatness of the pressure plate. If the pressure plate is badly heat-checked or deeply scored, replace the pressure plate and cover assembly.

Place the plate on the floor, force each individual finger down, then release quickly. If the finger does not return quickly, a binding condition is indicated, and the pressure plate should be replaced.

To check for uneven release finger height, follow this procedure:

Place the pressure plate and cover assembly on a new flywheel with three ¼-inch (0.250 inch) shims between the pressure plate and flywheel directly under the release fingers. Drill rod or precision washers may be used for the 0.250-inch shims.

Install the pressure plate to flywheel bolts and tighten evenly. Tap each finger lightly to stabilize its location.

Mount a dial indicator on a block. With the indicator block resting on the flywheel, check the difference in finger height. If the difference in finger height is more than 0.031 inch, replace the pressure plate and cover assembly.

(c) **CLUTCH DISC.** Inspect the clutch disc facings for oil or grease. An excessive amount of grease in the pilot bushing or release bearing hub will find its way to the disc facings. Too much lubricant in the transmission or a plugged transmission vent will force the transmission lubricant out the input shaft and onto the disc facings.

Inspect the clutch disc for worn or loose facings. Check the disc for distortion and for loose rivets at the hub. Check for broken springs. Replace the disc assembly if any of these defects are present. Special care should be taken when installing a new disc to avoid dropping or contaminating it with oil or grease.

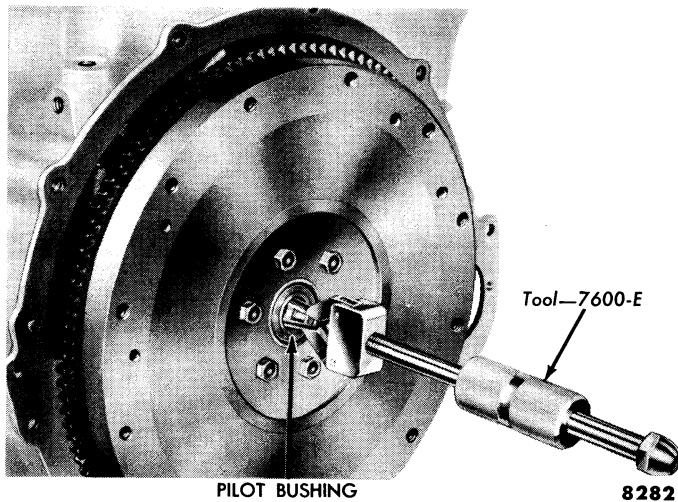

Fig. 5—Clutch Pilot Bushing Removal

(d) **PILOT BUSHING.** Check the fit of the clutch pilot bushing in the bore of the crankshaft. The bushing is pressed into the crankshaft and should not be loose. Inspect the inner surface of the bushing for wear or a bell-mouth condition. Replace the bushing if worn or damaged.

(e) **CLUTCH LINKAGE.** Inspect the clutch linkage and replace any parts that are worn or damaged.

(3) **PILOT BUSHING REPLACEMENT.** Install the tool shown in fig. 5, and remove the bushing from the flywheel.

Coat the pilot bushing bore in the crankshaft with a small quantity of wheel bearing lubricant.

CAUTION: Avoid using too much lubricant as it may be thrown onto the clutch disc when the clutch revolves.

Install the bushing with the tool shown in fig. 6.

(4) **INSTALLATION OF SUB-ASSEMBLIES.** The installation for the Thunderbird differs from those for

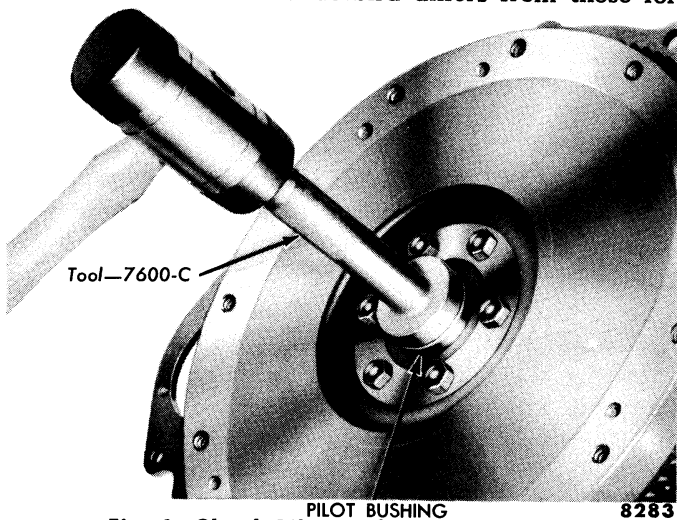

Fig. 6—Clutch Pilot Bushing Installation

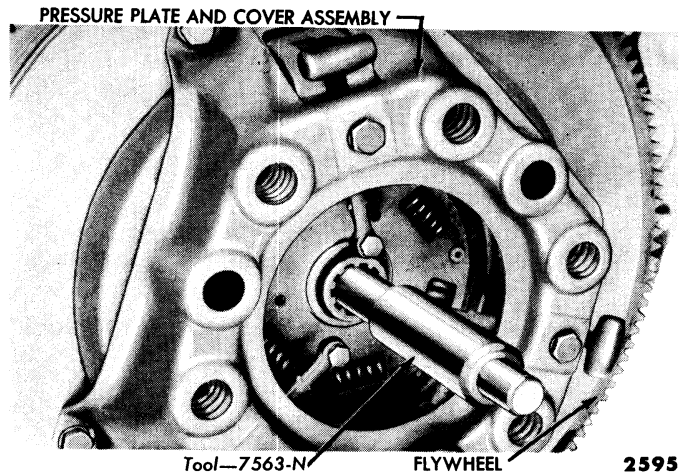

Fig. 7—Clutch Disc Installation

all other models.

(a) **CONVENTIONAL CLUTCH.** Place the clutch assembly in position on the flywheel. Align the splined hole in the center of the clutch disc with the pilot bearing in the flywheel using a pilot tool (fig. 7). Secure the clutch assembly to the flywheel with the attaching bolts. Draw the six bolts down evenly, then tighten each bolt to 17-20 foot-pounds torque.

After the clutch assembly is installed on the flywheel, apply a light film of Lubriplate, or its equivalent, on the sides of the driving lugs (fig. 8).

Clean the mating faces of the flywheel housing and the engine. Position the flywheel housing on the engine, and install all the attaching bolts except the two that hold the clutch equalizer bar bracket, then install the bracket. Install the bracket attaching bolts, then tighten all housing bolts to 40-50 foot-pounds torque.

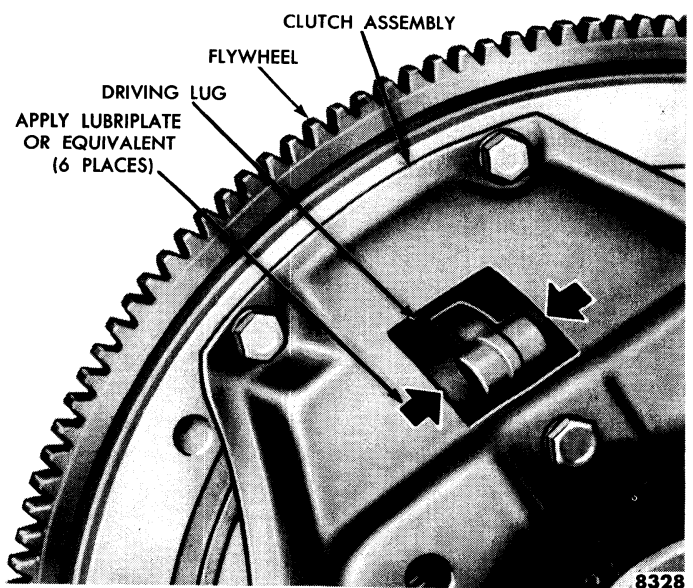

Fig. 8—Clutch Pressure Plate Lubrication

Install the clutch release bearing and hub assembly on the release lever assembly.

Connect the linkage as shown in fig. 1. Install the transmission. Adjust the clutch pedal total travel and free travel.

(b) **THUNDERBIRD CLUTCH.** Position the flywheel housing over the transmission input shaft upside down. Turn the flywheel housing 180° and position it on the engine. Install the attaching bolts in the engine block.

Place the clutch assembly in position on the flywheel. Align the splined hole in the center of the clutch disc with the pilot bearing in the flywheel using a pilot tool. Secure the clutch assembly to the flywheel with the

attaching bolts. Draw the six bolts down evenly, then tighten each bolt to 17-20 foot-pounds torque.

After the clutch assembly is installed on the flywheel, apply a light film of Lubriplate, or its equivalent, on the sides of the driving lugs (fig. 8).

Position the clutch release bearing and hub on the release lever assembly. Position the transmission on the flywheel housing. Install the attaching bolts, and tighten them to 40-50 foot-pounds torque. Install the drive shaft, then fill the transmission.

Connect the transmission linkage, and the clutch linkage. Adjust the clutch pedal total travel and free travel.

3. FLYWHEEL HOUSING ALIGNMENT

Alignment of the flywheel housing bore and rear face with the engine should be checked as a possible cause when any of the following occur: Excessive transmission gear wear; transmission jumping out of gear, especially high gear; vibration of the drive line; excessive pilot bushing wear; or noisy release bearings.

a. Alignment Check.

With the transmission and clutch release bearing removed, install the pilot tool shown in fig. 9. Clean the face of the flywheel housing bolt bosses (4) and install the adapter plate on the housing (fig. 9). Install the dial indicator on the pilot and adjust the holder to locate the indicator button between the scribed lines. Remove the flywheel housing cover and pull the engine flywheel outward or push it inward to remove normal

crankshaft end play. Set the dial indicator face to read zero.

Remove the engine spark plugs for easier turning, and pull the engine through one revolution. Be careful to keep the crankshaft all the way out or all the way in. Note the indicator readings at each of the four bolts attaching the adapted plate. Total indicator reading must not exceed 0.007 inches.

Remove the adapter plate and position the dial indicator to check the bore alignment (fig. 10). Pull the engine through one revolution and note the indicator readings at four equally spaced points. Total indicator reading must not exceed 0.010 inch.

b. Misalignment Correction, Engine in Car.

Since any change in face alignment will cause a change in bore alignment, it may be possible to correct

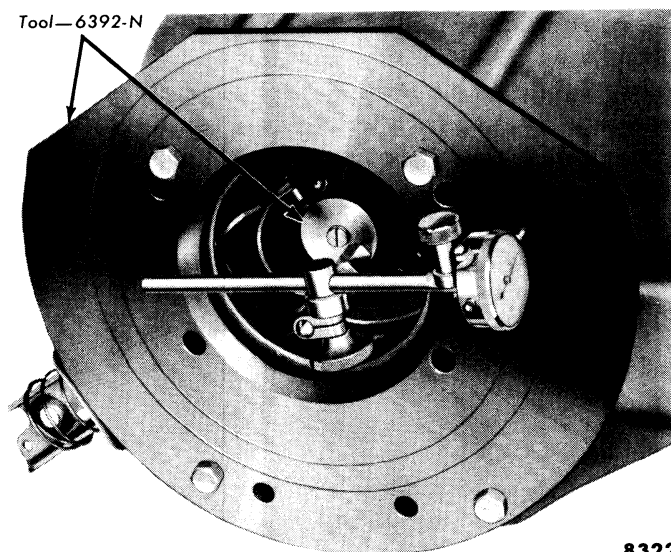

Fig. 9—Face Alignment Check

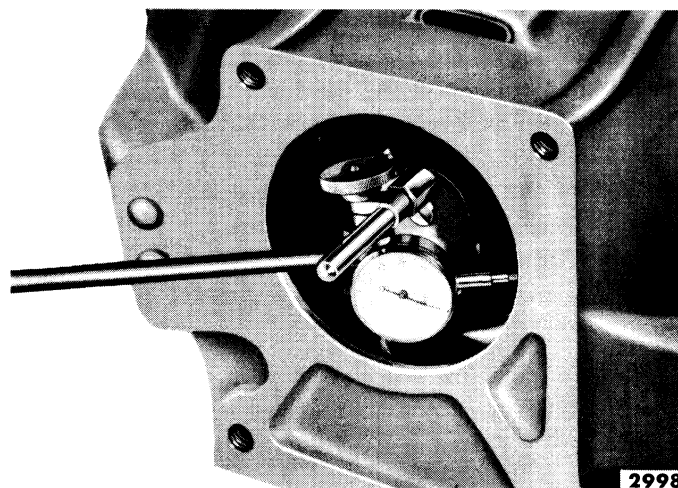

Fig. 10—Bore Alignment Check

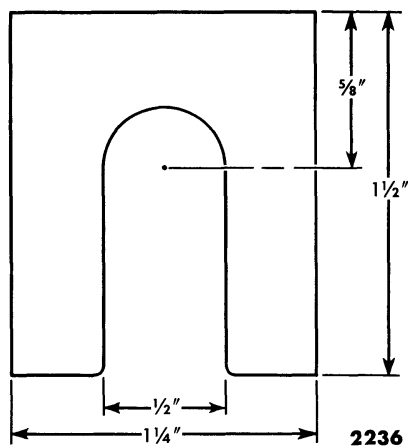

Fig. 11—Flywheel Housing Shim

bore alignment by changing face alignment. Face alignment can be changed by shimming between the flywheel housing and engine. Fig. 11 shows the type of shim which can be made locally.

NOTE: *If shims are used, a small quantity of gasket forming cement may be used to eliminate the air gaps between the shims. This operation is only necessary where the shimming is heavy or operating conditions are exceptionally dirty.*

Not more than 0.010 inch in shims may be used between the flywheel housing and engine. If a 0.010 inch shim will not bring face alignment within limits, replace the flywheel housing or use the old housing and place additional shims between the transmission and flywheel housing. Not more than 0.010 inch in shims may be used between the transmission and flywheel housing.

The addition shim required is one-half the maximum minus (—) indicator reading, and should be located at the point of maximum minus (—) indicator reading.

If both the bore and face alignment are out of limits, shim between the flywheel housing and engine to bring face alignment within limits. Check the bore alignment. If it is not within limits, replace the housing.

If bore alignment is out of limits and face alignment is within limits, shim the flywheel housing to the limit of face misalignment and check the bore alignment. If it is not within limits, replace the housing.

If bore alignment is within limits and face alignment

out of limits, shims should be placed between the flywheel housing and the transmission.

c. Misalignment Correction, Engine Out of Car.

The same procedure may be used to correct alignment with the engine out of the car as in the car, up to the point of replacing the flywheel housing. If the bore alignment cannot be brought within limits by shimming, follow this procedure:

Remove the flywheel housing from the engine and remove the dowel pins between the engine and flywheel housing. Install the flywheel housing and tighten the attaching bolts to normal torque. Install the adapter plate and dial indicator (fig. 9). Check the face alignment and shim as required to bring face alignment within limits (0.007 total indicator reading).

Position the indicator to check bore alignment (fig. 10). If bore alignment is not within limits, reduce the tension on the flywheel housing attaching bolts so the housing can be moved by striking it with a lead hammer or a block of wood and a steel hammer.

The lateral alignment should be brought within limits first, that is, an indicator reading within limits between the 9 o'clock and 3 o'clock positions on the bore circle. When the lateral alignment is within limits, the housing usually can be moved straight up or down without disturbing the lateral alignment. When the bore alignment is within limits, tighten the flywheel housing bolts to normal torque and recheck bore alignment.

NOTE: *If the flywheel housing cannot be moved enough to bring the alignment within limits, mark the holes restricting movement, and then remove the housing and drill the marked bolt holes 1/32 inch larger.*

When the flywheel housing bore alignment is within limits and the attaching bolts are at normal torque, ream the dowel pin holes 1/32 inch larger. Use a straight reamer and ream from the flywheel housing side. Oversize dowel pins can be made from drill rod stock.

Remove the flywheel housing and then install the oversize dowel pins in the engine block. Complete the assembly in the usual way.

4. TRANSMISSION CLEANING AND INSPECTION

Certain cleaning and inspection procedures apply to both the conventional 3-speed transmission and the overdrive transmission. To avoid repeating them throughout the chapter, these procedures are presented in this section.

a. Cleaning.

After the transmission has been disassembled, soak the parts, except the bearings, in a cleaning solvent until all the old lubricant is dissolved or loosened. Brush or scrape all foreign matter from the parts. Be careful not

to damage any of the parts with the scraper.

Wipe or blow compressed air on the parts until they are thoroughly dry.

To clean the bearings, rotate the bearings in the solvent until all old, hard lubricant is removed. Dry the bearings with compressed air, but do not spin the bearings. Slowly turn the bearings by hand and direct the air at right angles to the assemblies.

When the bearings are dry, lubricate them thoroughly with transmission lubricant, then cover them with a clean cloth until ready for use.

b. Inspection.

Inspect all transmission parts before assembly to determine if they should be replaced.

(1) **TRANSMISSION CASE.** Inspect the case for cracks, worn or damaged bearing bores, damaged threads, or other damage. If any of these conditions are present, replace the case.

Inspect the front face of the case, and file or grind off any minor nicks or burrs that could cause misalignment of the transmission with the flywheel housing.

(2) **GEAR SHIFT HOUSING ASSEMBLY.** It is not necessary to disassemble the gear shift housing assembly to inspect the parts. Check the operation and condition of the shift levers and forks. If binding occurs when the levers are operated, disassemble the housing assembly, and replace the faulty parts.

(3) **BEARINGS.** Examine the bearing assemblies for cracked cups or races. Check the races for roughness. Inspect the balls and rollers for looseness, wear, chipping, flaking, or other damage. Check the bearings for binding on the shafts or looseness in the bores. If any of these conditions are present, replace the bearings.

(4) **CLUSTER GEAR AND COUNTERSHAFT.**

Replace the cluster gear if the gear teeth are chipped or badly worn. Replace the countershaft if the shaft is bent, grooved, or has badly worn bearing surfaces.

Check the end play between the cluster gear and the thrust surfaces of the transmission case. If the end play is not between 0.004-0.018 inch, replace the cluster gear.

(5) **REVERSE IDLER GEAR ASSEMBLY.** Replace the reverse idler gear if the gear is badly worn or if the gear teeth are chipped or burred. Replace the reverse idler gear shaft if it is excessively worn or scored.

If the bushing in the 3-speed transmission reverse idler gear is worn or damaged, replace the gear and bushing assembly. The bushing is not serviced separately.

(6) **INPUT SHAFT ASSEMBLY.** Replace the input shaft if it is worn or bent, or if the gear has chipped, worn, or missing teeth, or if the roller bearing bore is rough.

(7) **OUTPUT SHAFT ASSEMBLY.** Replace all output shaft gears and roller bearings that are chipped, burred, or badly worn.

Check the intermediate gear end play. If the end play is not between 0.002-0.011 inch, replace the intermediate gear.

Check the intermediate to high sleeve for free movement on its hub. Check the sleeve for wear at the spline teeth ends.

Check the blocking rings for wear on the grooves and teeth.

Check the fit of the low and reverse sliding gear on the output shaft splines. Replace the gear or the output shaft if the outside diameter fit of the helical splines exceeds 0.002 inch.

Replace the speedometer driving gear if the gear teeth are worn or broken. Be sure to install the correct size replacement gear.

Replace the output shaft if it is worn or bent.

5. CONVENTIONAL 3-SPEED TRANSMISSION

The conventional 3-speed transmissions used in all cars except the Police Interceptor, differ only in gear ratios. The 3-speed transmission used in the Police Interceptor is basically the same as the overdrive transmission.

a. Construction.

The conventional 3-speed transmission has three forward speeds and one reverse speed. All transmission gears are helical. The constant-mesh second (intermediate) and third (high) gears are engaged by a synchronizer which reduces the possibility of gear clashing.

The input shaft (fig. 12) is supported by a ball

bearing which is pressed onto the shaft and installed in a bore at the front of the transmission case.

The forward end of the output shaft is supported by a roller-type pilot bearing installed in the input shaft. A ball bearing assembly supports the output shaft at the rear end of the transmission case, and a bushing supports the shaft at the rear end of the transmission extension.

The intermediate gear rotates on the output shaft. The low and reverse sliding gear is splined to the output shaft.

The synchronizer assembly is mounted at the forward end of the output shaft. The forward synchronizer

blocking ring is mounted on the rear of the input shaft gear, and the rear blocking ring is mounted on the front of the intermediate gear.

An oil seal is pressed into the drive shaft end of the transmission extension housing. An oil baffle is used behind the transmission input shaft bearing.

b. Removal.

The transmission removal procedures for the Thunderbird differ from those for the conventional cars.

(1) **CONVENTIONAL CARS.** Drain the transmission, then disconnect the gear shift linkage at the transmission. Remove the speedometer cable and gear. Remove the drive shaft. Remove the bolts which attach the transmission extension to the engine rear support (fig. 13). Remove the frame cross member and engine rear support.

Remove the bolts and lock washers which attach the transmission to the clutch housing, then install two guide pins. Move the transmission assembly to the rear until the input shaft splines clear the clutch housing, then lower the transmission and pull forward to remove it from the car.

(2) **THUNDERBIRD.** Drain the transmission, then disconnect the gear shift linkage at the transmission. Remove the speedometer cable and gear. Remove the drive shaft. Remove the cover from the bottom of the clutch housing, then remove the starter from the clutch housing.

Disconnect the clutch pedal linkage from the clutch

release lever.

Raise the rear of the engine slightly, then disconnect the engine rear mount and remove the frame cross member. Place a transmission jack under the transmission, then remove the bolts that secure the transmission to the clutch housing. Move the transmission toward the rear of the car so that the clutch parts can be removed from the clutch housing.

Slide the clutch release bearing and hub assembly off the end of the release lever assembly. Remove the pressure plate and cover assembly and the clutch disc from the engine flywheel.

Remove the bolts that attach the clutch housing to the engine, lower the clutch housing, then remove the transmission.

NOTE: *The clutch housing must be turned upside down to remove it from the car.*

c. Disassembly.

The transmissions removed from either the conventional cars or the Thunderbird are disassembled in the same way.

(1) **GEAR SHIFT HOUSING REMOVAL.** Remove the bolts that secure the gear shift housing to the transmission case, and remove the gear shift housing and the two shifter forks. Drive the countershaft retainer pin out of the transmission case with a drift. This pin also holds the reverse idler gear shaft.

(2) **REMOVE OUTPUT SHAFT, EXTENSION, AND REVERSE-IDLER GEAR.** Remove the cap

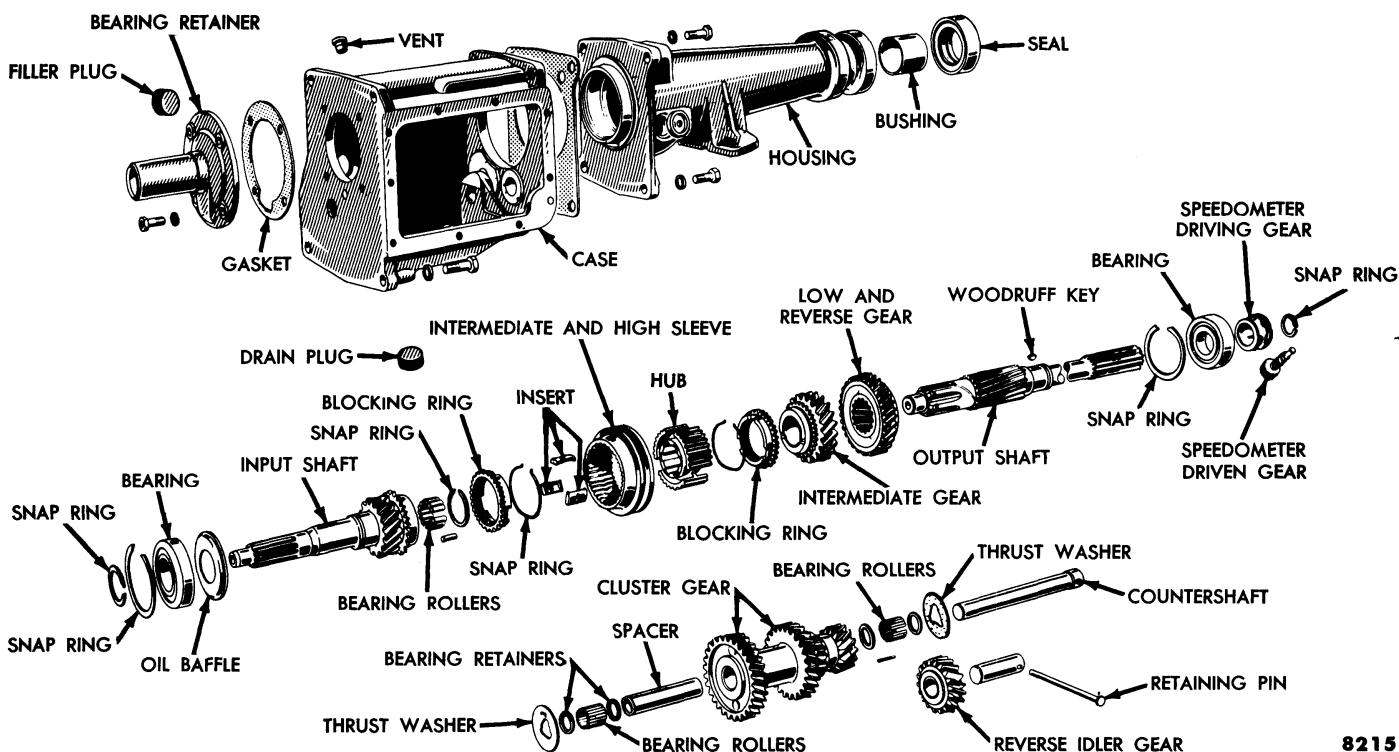

Fig. 12—Conventional 3-Speed Transmission

screws and washers that secure the extension (fig. 12) to the transmission case. Turn the extension $\frac{1}{4}$ turn counterclockwise to permit removal of the countershaft. Drive the countershaft to the rear so that it clears the front of the transmission case. Push the countershaft out the rear of the case, with a cluster gear roller retainer shaft tool. Leave the cluster gear and dummy shaft in the case. Remove the extension and output shaft assembly from the rear of the transmission case. Drive the reverse idler gear shaft out of the case with a brass drift, then remove the reverse idler gear.

(3) **REMOVE INPUT SHAFT ASSEMBLY.** Remove the bolts that secure the input shaft bearing retainer to the transmission, and remove the retainer and gasket. Tap the input shaft assembly out through the front of the transmission case with a soft hammer.

d. Disassembly of Sub-Assemblies.

Follow the procedures given below to disassemble each transmission sub-assembly, then thoroughly clean and inspect each part.

(1) **OUTPUT SHAFT ASSEMBLY.** Remove the snap ring that holds the output shaft assembly in the extension. Tap the output shaft (fig. 12) out of the extension, with a soft hammer. Remove the transmission output shaft synchronizer snap ring and pull or press the synchronizer assembly, intermediate gear, and sliding gear off the output shaft.

Remove the snap ring that secures the speedometer driving gear on the output shaft, then remove the gear. Remove the speedometer gear ball. Press the output shaft rear bearing off the shaft.

(2) **SYNCHRONIZER ASSEMBLY.** Push the synchronizer hub out of the sleeve (fig. 12). This releases the three synchronizer inserts. Remove the synchronizer insert springs from each end of the synchronizer hub.

(3) **INPUT SHAFT ASSEMBLY.** Remove the snap

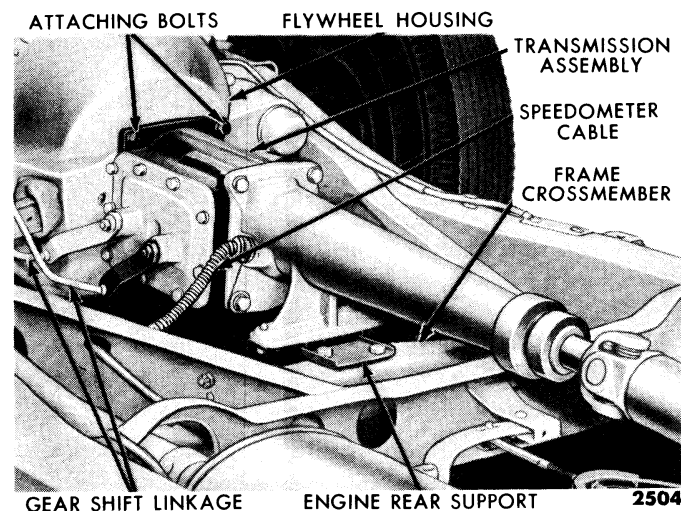

Fig. 13—Transmission Installation—Conventional Cars

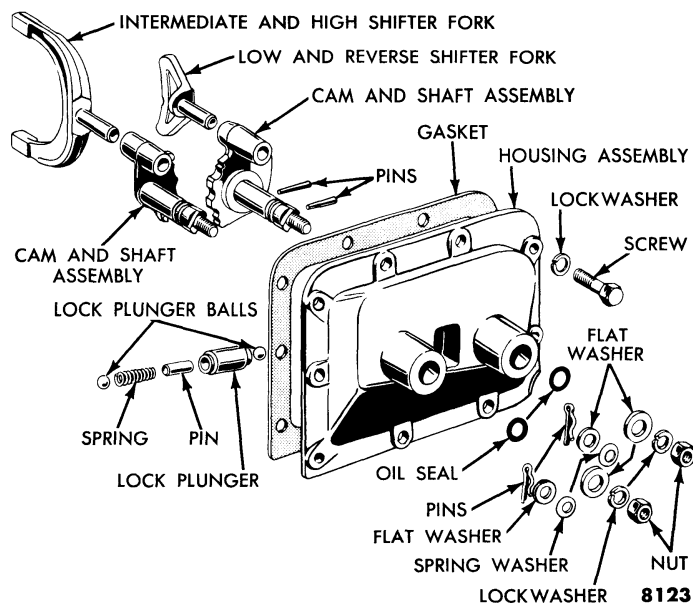

Fig. 14—Gear Shift Housing

ring that secures the bearing on the shaft, and press the bearing off the shaft. Remove the oil baffle from the shaft (fig. 12).

(4) **COUNTERSHAFT GEAR ASSEMBLY.** Remove the countershaft gear, thrust washers, and tool from the transmission case. Remove the bearing retainers, bearing rollers, spacers, and dummy shaft from the countershaft gear.

(5) **GEAR SHIFT HOUSING ASSEMBLY.** It is not necessary to disassemble the gear shift housing assembly to determine the condition of the housing parts. Check the condition of the shift levers and forks. If there is any binding or possibility of shifting into two gears at once when the lever is operated, disassemble the housing as follows:

Remove the shift levers from the camshafts (fig. 14). Remove the camshaft retaining pins and pull the shifter fork and cams out of the gear shift housing. With the cams removed, the interlock balls, retainer, and spring will fall out of the gear shift housing. Pull the shifter forks out of the cams, then remove the seal rings from the cams.

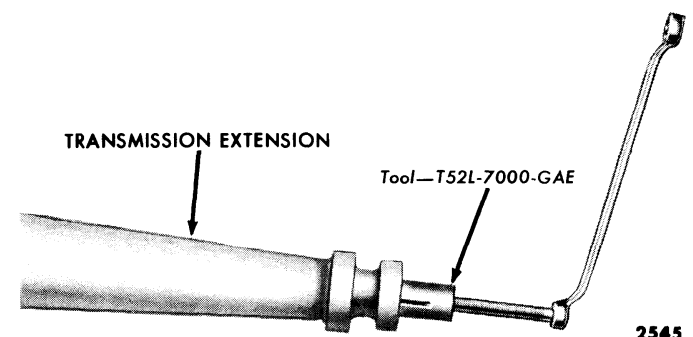

Fig. 15—Oil Seal and Bushing Removal

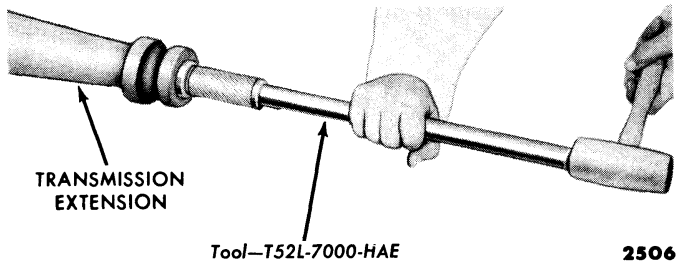

Fig. 16—Transmission Extension Rear Bushing Installation

(6) **TRANSMISSION EXTENSION HOUSING.** Remove the oil seal and bushing from the extension housing with the tool shown in fig. 15.

NOTE: *This tool can be used to remove the oil seal and bushing while the transmission is in the car.*

e. Assembly of Sub-Assemblies.

When assembling the transmission sub-assemblies, be sure that no backlash exists between the splined shafts and their mating parts and that all thrust clearances are within the specified limits. Otherwise, the transmission may jump out of gear under certain conditions.

(1) **COUNTERSHAFT GEAR.** Position the countershaft bearing spacer in the countershaft gear (fig. 12). Insert a dummy shaft in the countershaft gear assembly. Install 22 rollers in each end of the gear cluster. Coat the bearing retainers and thrust washers with grease to help keep them in place. Install a bearing retainer at each end of the countershaft gear.

Two thrust washers are used at the rear. Place the thrust washer with the slotted hole next to the cluster assembly, with the babbitt side toward the steel washer and the steel thrust washer next to the transmission case. Install the front thrust washer between the transmission case and cluster gear making sure the tongue on the thrust washer is entered in the groove provided in the case. Place the cluster gear assembly with the dummy shaft in place in the transmission case, allowing it to rest on the bottom of the case.

(2) **INPUT SHAFT.** Install the oil baffle and input shaft bearing on the input shaft. Press the bearing into

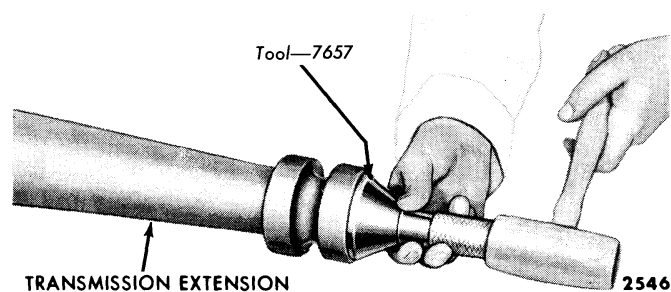

Fig. 17—Transmission Extension Oil Seal Installation

place, applying pressure to the inner race, and install the snap ring on the shaft to secure the bearing (fig. 12). Install the snap ring on the input shaft bearing. Coat the output shaft front bearing rollers with cup grease, then install the rollers in the input shaft.

(3) **SYNCHRONIZER.** Install a synchronizer snap ring at each end of the hub (fig. 12) with the ends of the springs between the same two inserts. Place the synchronizer inserts on the synchronizer hub. Align the etched mark on the sleeve and push the hub inside the synchronizer sleeve. If a new hub or sleeve is installed, be sure that the backlash does not exceed 0.001 inch between the hub and the sleeve. Place the synchronizer ring on the synchronizer assembly, making sure the slots are in line with the synchronizer inserts.

(4) **OUTPUT SHAFT.** Install the transmission extension rear bushing as shown in fig. 16. Install the oil seal in the rear of the transmission extension (fig. 17).

NOTE: *These tools can be used to install the bushing and oil seal while the transmission is in the car.*

Install the output shaft rear bearing on the shaft, and press it into place. Install the speedometer gear key in the shaft. Install the speedometer gear on the shaft and secure it with the lock ring (fig. 12). Install the sliding gear, intermediate gear, and the synchronizer assembly on the output shaft, and secure them with the snap ring.

(5) **GEAR SHIFT HOUSING.** Install new seal rings in the grooves in the shifter cams. Place one cam assembly in position in the gear shift housing and install the retaining pin. Assemble the interlock spring and balls in the interlock and install the interlock assembly in the gear shift housing. Place the other cam assembly in position and install the retaining pin. Install the gear shift levers on the camshafts. Assemble the shifter forks to the cams.

f. Assembly.

Place the reverse idler gear in position in the transmission case, and install the reverse idler gear shaft, making sure to align the retainer pin hole with the hole in the transmission case.

Position the input shaft in the front of the transmission case, making sure the snap ring on the bearing is firmly seated against the case. Install the retainer with a new gasket, on the input shaft with the drain groove at the bottom. Install the bolts and lock washers that secure the retainer to the transmission case.

Install the output shaft assembly in the transmission extension, securing it with the snap ring. Place a new gasket on the front of the transmission extension, then install the output shaft assembly and extension on the

transmission case. Use care not to displace any of the bearing rollers in the input shaft.

Turn the extension to provide access to the countershaft, raise the countershaft gear assembly and thrust washers into position, then install the countershaft from the rear of the case, pushing the dummy shaft out the front of the case.

NOTE: *Care must be taken when installing the countershaft to avoid damaging the thrust washers, bearing spacer, or bearing rollers.*

Align the retainer pin hole with the hole in the case, and install the countershaft and reverse idler shaft retainer pin.

Turn the extension on the transmission case, aligning the bolt holes. Install the washers and bolts, using the internal tooth lock washers on the two lower cap screws.

Install the gear shift housing on the transmission case, using a new gasket, and secure it with lock washers and bolts.

g. Installation.

The transmission installation procedures for the Thunderbird differ from those for the conventional cars.

(1) **CONVENTIONAL CARS.** Place the transmission in position under the car. Make sure that the mounting surfaces on the flywheel housing and transmission are free of dirt, paint, and burrs. Install guide pins in two of the clutch housing bolt holes. Move the transmission forward until the input shaft enters the pilot bushing, using the guide pins to facilitate the alignment of the input shaft and clutch disc splines.

When the transmission is correctly positioned on the clutch housing, remove the guide pins. Install the transmission to clutch housing attaching bolts and lock washers, then tighten the bolts to 40-50 foot-pounds torque. Position the frame cross member on the car frame, then install and tighten the attaching bolts. Install the bolts which secure the transmission extension to the engine rear support. Tighten the bolts to 40-50 foot-pounds torque. Install the drive shaft, then install the speedometer drive gear and cable.

Connect the gear shift linkage at the transmission. Fill the transmission with the correct grade and proper amount of lubricant.

(2) **THUNDERBIRD.** Position the transmission on the cross member. Position the clutch housing over the transmission input shaft upside down. Raise the clutch housing, then turn the clutch housing 180° and position it on the engine. Install the attaching bolts in the engine block, and tighten them to 40-50 foot-pounds torque.

Install the clutch assembly on the flywheel. Move the transmission forward and install it on the clutch housing. Install the attaching bolts, and tighten them to 40-50 foot-pounds torque. Be sure the transmission is properly aligned on the clutch housing and with the engine crankshaft.

Install the frame cross member under the transmission extension, then connect the rear engine mount.

Connect the transmission and clutch linkage. Install the drive shaft. Install speedometer cable and gear in the transmission. Fill the transmission with the correct grade and proper amount of lubricant. Adjust the clutch pedal total travel and free travel.

6. OVERDRIVE TRANSMISSION

The overdrive transmission, available for all cars, consists of a 3-speed transmission designed especially for use with an overdrive unit (fig. 18). Complete service procedures for this transmission and for the overdrive unit, are given in this section.

The overdrive unit provides an automatic fourth gear which reduces the speed ratio between the engine and the rear axle.

a. Construction and Operation.

The construction and operation of the transmission unit of the overdrive transmission is basically the same as the conventional 3-speed transmission. Both transmissions have some design differences because of the overdrive unit installation.

(1) **OVERDRIVE UNIT MECHANICAL OPERATION.** The sun gear (figs. 19 and 20) is a slip-fit over the transmission output shaft and is the controlling unit

of the mechanical assembly. The sun gear assembly has three sets of teeth. One set is in constant engagement with the planetary pinions, and a second set is in constant engagement with the balk ring gear. The third set, known as the lock-up teeth, are manually engaged and disengaged by the shifter fork and collar.

When the lock-up teeth are engaged with the internal teeth of the planetary cage, the sun gear is locked to the transmission output shaft (overdrive locked). When the teeth are out of engagement, the sun gear is free to revolve about the transmission output shaft (automatic control).

Automatic control of the sun gear is effected through the balk ring gear assembly with which it is constantly engaged. A sliding pawl automatically engages and disengages slots in the outer surface of the balk ring gear, according to vehicle speed. With the pawl out of engagement, the balk ring gear and sun gear revolve with the planetary pinions (direct drive). When the

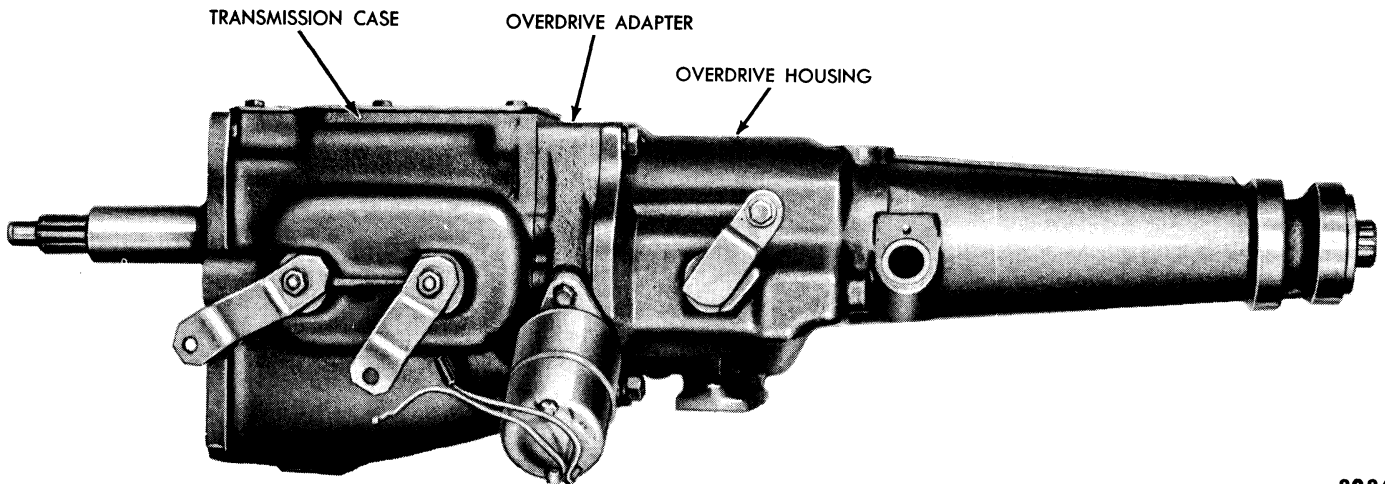

8284

Fig. 18—Overdrive Transmission—Conventional Cars

pawl slides into engagement, it holds the balk ring gear and the sun gear stationary, and the pinions are forced to “walk around” the sun gear (overdrive).

The power flow through the overdrive unit is described for the three drive conditions under which the unit is operated.

(a) **FREE-WHEELING DRIVE.** When the overdrive dash control is pushed in, the shift rail (fig. 20) is moved to its forward position, holding the sun gear lock-up teeth out of engagement with the planetary cage internal teeth. The sun gear and the balk ring gear assembly which controls it are now free to rotate as long as the pawl remains out of the slots in the outer surface of the balk ring gear assembly (under 27 m.p.h.).

The free-wheeling drive power flow is shown in fig. 21. The transmission output shaft transmits power to the free-wheel clutch cam through a spline drive (fig. 27). When the engine driving torque is applied to the clutch cam, the clutch rollers are forced outward to wedge against the outer race which is assembled integral with the overdrive output shaft. In this way, the torque is

transmitted directly from the transmission output shaft to the overdrive output shaft. All the overdrive gears and associated parts turn as a unit under free-wheeling drive conditions.

If the driving torque is removed (throttle closed), the overdrive mainshaft attempts to drive the transmission output shaft. However, the clutch rollers release their wedging action by rolling to the low portion of the cam, and the outer race and overdrive mainshaft assembly overrun the transmission output shaft. In effect, the overdrive mainshaft is disconnected from the transmission output shaft, and the car free-wheels as long as the transmission output shaft rotation is slower than the overdrive mainshaft rotation.

(b) **OVERDRIVE.** If the sun gear is held against rotation by the pawl (fig. 22), the power flow is as shown in fig. 23. The transmission output shaft drives the planetary cage, forcing the pinions to rotate or “walk around” the sun gear. The pinions are meshed in the internal gear on the overdrive mainshaft and force it to rotate at a higher rate than the transmission output

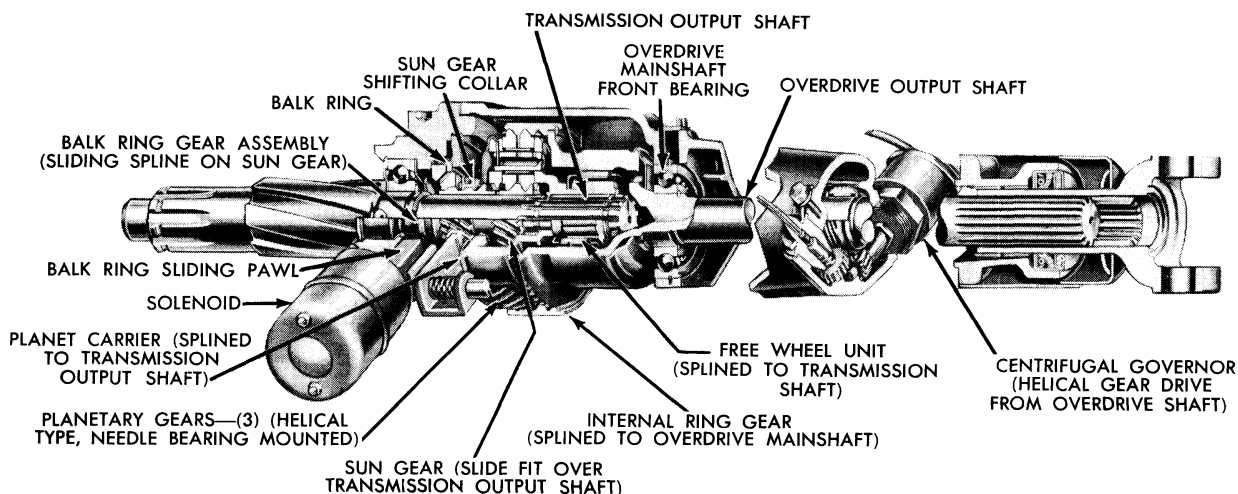

Fig. 19—Overdrive Assembly—Cutaway View

8290

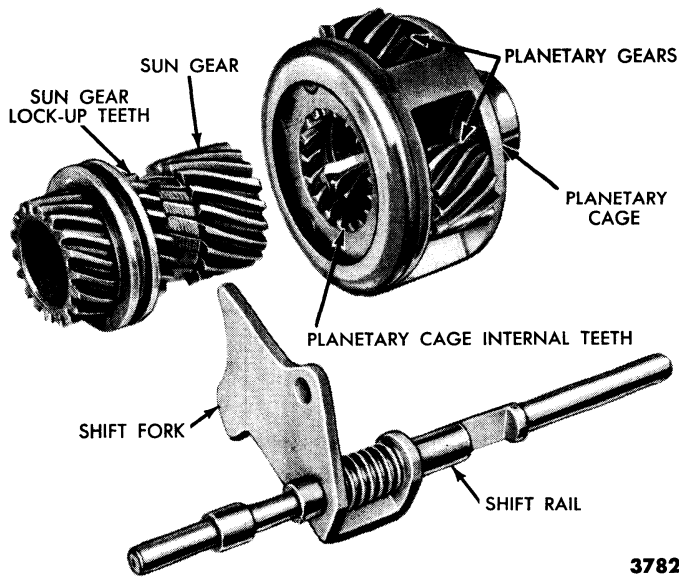

Fig. 20—Planetary and Sun Gears

shaft. For each full revolution of the overdrive mainshaft, the transmission output shaft turns 0.7 of a revolution. Since the overdrive mainshaft is turning more rapidly than the transmission output shaft, the overdrive clutch remains in the free-wheel position.

When the car is permitted to coast, force can be transmitted to the engine by the rear wheels as long as the sun gear is held against rotation.

(c) **LOCKED OUT DRIVE.** When the overdrive dash control is pulled out, the shift rail is moved to the rear position. The shifter fork moves the sun gear to the rear position, and this motion engages the sun gear lock-up teeth with the teeth in the planetary cage (fig. 20). The sun gear, the planetary cage, and the planetary pinions are thus locked together. Since the pinions cannot rotate if locked to the planetary cage, the overdrive mainshaft internal gear is forced to rotate with the transmission output shaft (fig. 24).

When the transmission is shifted into reverse (over-

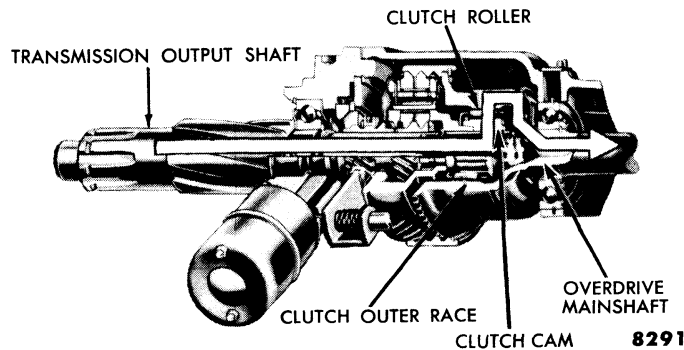

Fig. 21—Forward, Free-Wheeling Drive

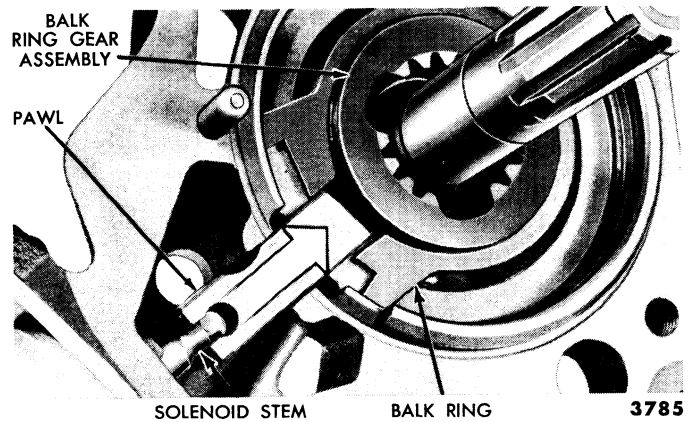

Fig. 22—Action of Pawl Mechanism

drive control pushed in), the shift rail must be moved to the rear position to lock the sun gear and the planetary pinion cage, since the overdrive clutch will not transmit a reverse drive. The shift rail is moved to the rear position by a cam on the reverse gear shifter fork inside the transmission housing. The cam automatically moves the shift rail to the rear, locking the overdrive when the transmission is shifted into reverse.

(2) **OVERDRIVE UNIT ELECTRICAL OPERATION.** While the mechanical portion of the overdrive may be considered the “working” part, the drive conditions are controlled automatically by the electrical circuit. The circuit consists of a solenoid, governor, kick-down switch, relay, and connecting wires. The elements of the control circuit are wired as shown in fig. 25.

The power circuit or solenoid circuit (represented by the heavy lines in fig. 25), supplies current to energize the solenoid. The control circuit (represented by the light lines in fig. 25), controls the flow of current to the solenoid by closing or opening the relay contacts in the power circuit. The operation of the electrical circuit can be best described by explaining what happens under each of the three methods of control.

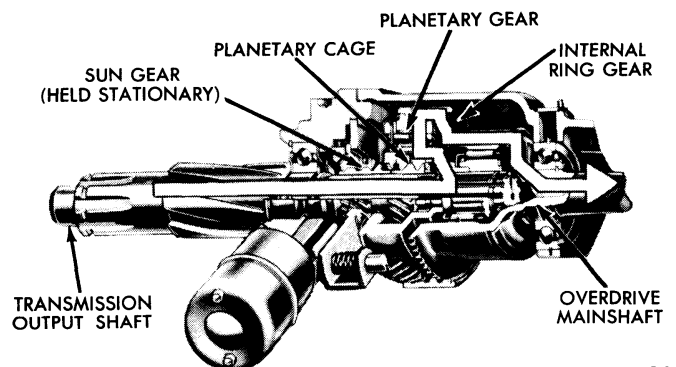
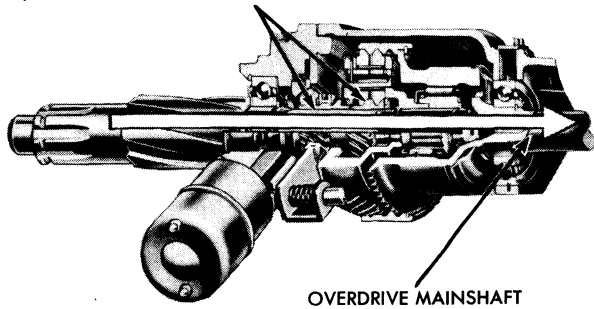

Fig. 23—Overdrive Power Flow

SUN GEAR AND PLANETARY CAGE LOCKED TOGETHER
(COMPLETE OVERDRIVE MECHANISM TURNS AS A UNIT)



8293

Fig. 24—Locked Out Drive Power Flow

(a) **SPEED CONTROLLED.** The closing of the control circuit is dependent on the governor contacts. As long as the car speed remains below the cut-in speed of the governor (approximately 27 m.p.h.), the overdrive unit will remain in direct drive.

When the car speed reaches the cut-in point of the governor, the increased centrifugal force on the governor weights closes the governor contacts to complete the electrical control circuit to ground. The resulting current flow through the control circuit energizes the relay coil which closes the relay contacts, completing the power circuit to the solenoid coils. Current now flows through both the actuating coil and the holding coil of the solenoid. The circuit of the heavier windings of the actuating coil is completed through a set of grounding contacts in the solenoid housing. Energized by a heavy current flow, the actuating coil moves the

solenoid armature to the “apply” position against the stem and pawl. As the armature completes this movement, it opens the actuating coil grounding contacts which protects the actuating coil by cutting off the heavy current flow through its windings. Since the holding coil remains connected in the circuit, the armature is held in the “apply” position once it has been moved there by the actuating coil.

The pawl is not forced to engage the balk ring gear assembly by direct action of the solenoid armature. Instead, the motion of the armature is applied to the stem and pawl through a spring, so that the pawl is spring-loaded against the balk ring which prevents the pawl from engaging the balk ring gear. When torque is released from the overdrive mainshaft, by letting up on the accelerator, the balk ring gear reverses its direction of rotation. This reversal of rotation turns the balk ring sufficiently to permit the spring-loaded pawl to easily engage a slot in the balk ring gear. This stops the rotation of the balk ring gear and sun gear for overdrive operation.

At the same time that the above mentioned spring was being loaded between the stem and the armature to urge the pawl into engagement, a second spring was also being loaded between the armature and the solenoid frame. Thus, when the solenoid is de-energized, and the driving torque is released, this second spring will withdraw the pawl from engagement.

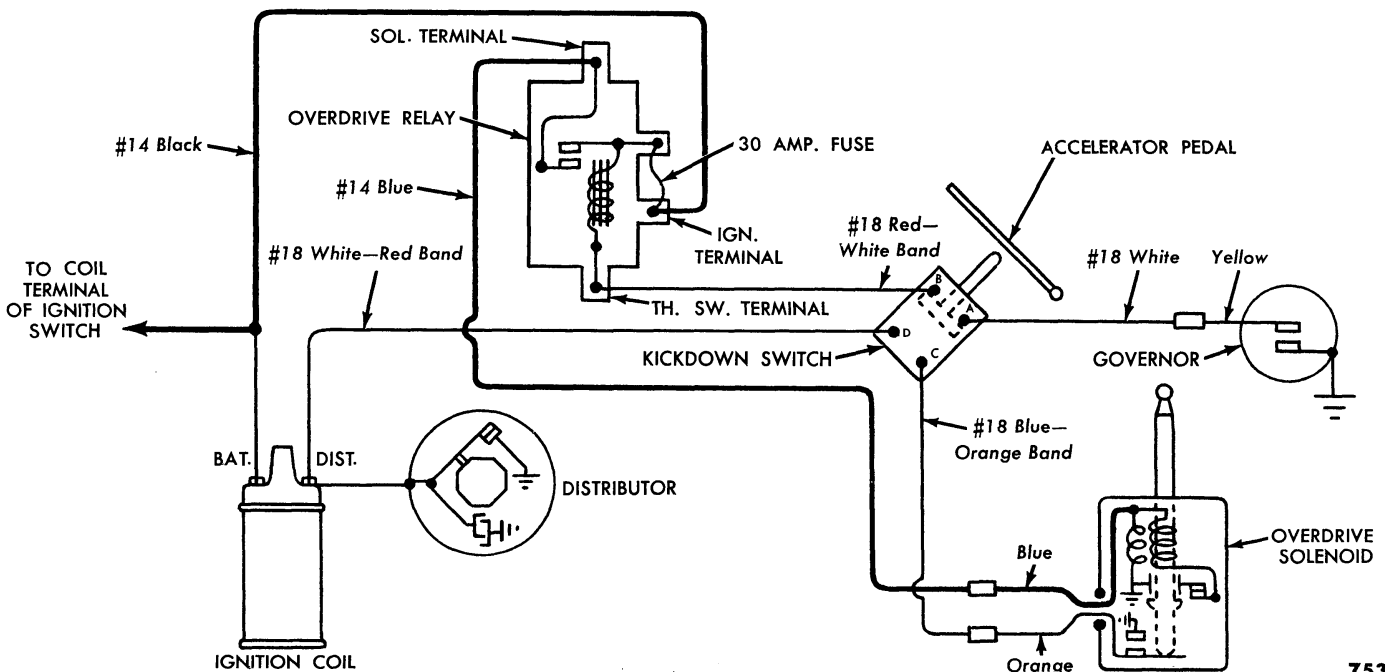

7531

Fig. 25—Overdrive Electrical Circuit

The overdrive shifts down automatically when the car speed drops to the cut-out speed of the governor (approximately 21 m.p.h.). At cut-out speed, the governor contacts open, interrupting the control circuit, thus causing the relay contacts to open. The power circuit to the solenoid is now open, and spring action returns the solenoid armature to the "out" position, withdrawing the pawl from the control plate. The overdrive now returns to direct drive.

(b) **DRIVER CONTROLLED KICKDOWN.** As previously stated, when the overdrive is engaged, the engine turns only 0.7 as fast as when the overdrive is in direct drive. The power available for acceleration is reduced at this reduced engine speed, and at certain times, it is desirable to shift the overdrive into direct drive to permit greater acceleration without reducing the car speed to the overdrive cut-out point. The downshift from overdrive to direct drive is accomplished by the pressure of the foot throttle on the kickdown switch.

The action of the switch affects two different circuits in order to perform two different functions. First, it opens the control circuit to de-energize the solenoid for disengagement of the overdrive. However, due to torque reaction, the pawl is held in engagement with the slot in the balk ring gear and cannot release until the driving torque is removed. At the time that it opens the control circuit, the kickdown switch also closes a set of contacts in the ignition grounding circuit, in order to bypass the ignition breaker contacts. The resulting interruption of the ignition releases the driving torque so that the pawl moves out of engagement, and the solenoid armature returns to the "unapplied" position.

The "shorting out" of the ignition breaker points occurs only as long as is necessary for the withdrawal of the pawl and solenoid armature (approximately one-half revolution of the crankshaft). The ignition grounding circuit also incorporates a second set of contacts mounted on the solenoid housing opposite the armature. As the solenoid armature reaches the end of its return travel to the "unapplied" position, it comes against these contacts to open the ignition grounding circuit and thus restores the ignition circuit to normal. Power is now applied through free-wheeling drive to the rear wheels as long as the engine is kept under a pulling load.

(c) **CONTROL LOCKED OUT.** The overdrive is "locked out" when the overdrive dash control is pulled out or the transmission is shifted into reverse. When the overdrive is operated in the "lock out" position, the solenoid will be energized when the car speed is above the cut-in speed. However, the pawl is prevented from engaging a slot in the balk ring gear, as the shift rail is in the rear position. Therefore, with the overdrive "locked out," the power is applied to the rear wheels through direct drive, regardless of the car speed.

b. Removal.

The overdrive unit cannot be removed from the car as a separate assembly. Remove the transmission and overdrive as a unit, then remove the overdrive unit from the transmission.

Remove the overdrive control cable assembly. Disconnect the solenoid and governor wires at the bullet connectors. Remove the transmission and overdrive assembly from the car.

c. Disassembly.

Mount the overdrive and transmission assembly on a work stand or in a vise.

Remove the screws which attach the solenoid to the overdrive, then rotate the solenoid and remove it from the overdrive unit.

Remove the rubber cover from the governor, then remove the governor assembly. Remove the cover and gasket from the transmission housing. Remove the three overdrive housing bolts and one stud nut, the manual control shaft pin, and the snap ring cover plug located on top of the overdrive housing (fig. 26).

Pull the manual control lever and shaft out as far as it will go. Spread the snap ring with a snap ring tool, then remove the overdrive housing by tapping the overdrive mainshaft with a soft-faced hammer. Remove the housing to bearing retainer ring.

Remove the overdrive output shaft from the assembly. Catch any of the clutch rollers which drop out (fig. 27). Remove the rest of the rollers. Remove the clutch assembly retainers (fig. 28), the clutch and planetary gear assemblies, and the sun gear and shift rail (fig. 29). The plate and trough assembly, balk ring gear assembly, and pawl can now be removed by taking out the snap ring (fig. 30).

Remove the snap rings which retain the shift fork ring on the sun gear, then remove the ring from the gear.

Remove the snap ring which retains the ring gear on the overdrive output shaft, then remove the gear from the shaft. Remove the speedometer driving gear snap ring, then remove the gear from the shaft. Drive the key out of the keyway in the shaft, then press the overdrive output shaft bearing off the shaft.

Lift the shift rail spring out of the overdrive housing, then remove the manual control lever and shaft. If the lever shaft oil seals are damaged, remove the seals, then tap a new seal into the recess in the housing. Remove the seal and bushing from the overdrive housing (fig. 15).

Remove the transmission input shaft bearing retainer.

Remove the first and reverse shift lever retaining pin from the bottom, then pull the lever outward to release

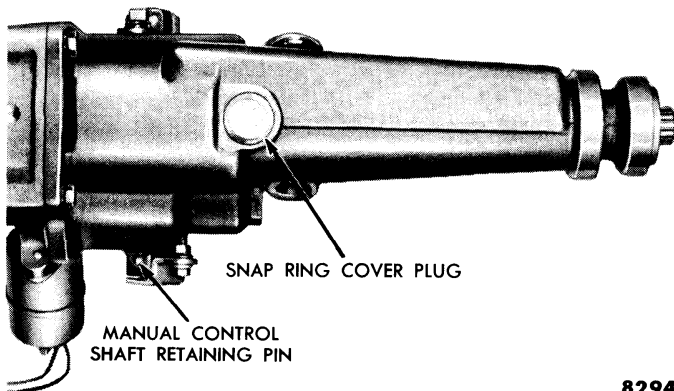

8294

Fig. 26—Overdrive Housing

the fork (fig. 31). Remove the second and high shift lever shaft retaining pin, then pull the lever outward to release the fork.

Remove the adapter plate and transmission output shaft and gears as an assembly.

CAUTION: *Hold the synchronizer assembly together during shaft removal.*

Remove the stud from the rear of the case.

Remove the shift forks from the case. Remove the snap ring from the output shaft, then slide the synchronizer, second speed gear, and first and reverse gear off the shaft.

Remove the snap ring which retains the output shaft bearing in the adapter plate, then remove the shaft and bearing from the plate (fig. 32).

Remove the oil baffle from the bearing. Remove the snap ring which retains the bearing on the output shaft, then press the bearing off the shaft (fig. 33).

Remove the lock plate which retains the reverse idler shaft and countershaft in the case. Push the countershaft

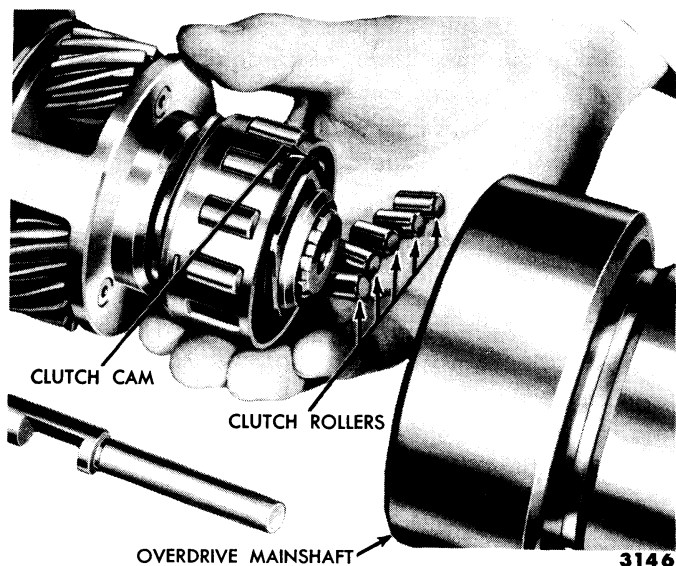

3146

Fig. 27—Overdrive Output Shaft Removal

CLUTCH-TO-PLANETARY-CAGE RETAINER

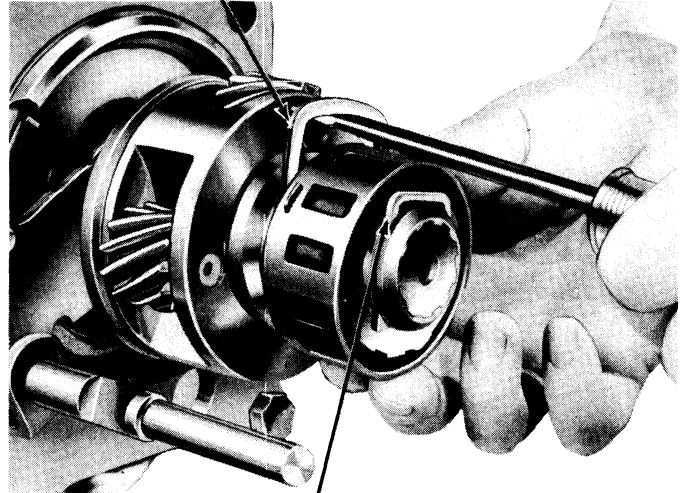

CLUTCH TO TRANSMISSION OUTPUT SHAFT RETAINER

3792

Fig. 28—Clutch Assembly Retainers Removal

out of the case, from the front of the transmission with a pilot shaft (T55P-7111-A). The pilot shaft will replace the countershaft as it is driven out. Since the pilot shaft is shorter than the countershaft, the cluster gear will drop to the bottom of the transmission case, providing sufficient clearance for the removal of the input shaft. Tap the input shaft and bearing assembly out of the case with a soft-faced hammer. Lift the cluster gear out of the case while holding the washers and pilot shaft at the small end of the cluster gear to prevent the roller bearings and pilot shaft from falling out of the cluster gear. Note the position of the thrust washers at each end of the cluster gear to assure correct installation at assembly.

Drive the reverse idler gear shaft out of the case with a brass drift and a hammer, then remove the idler gear from the case. Remove the nuts and lock washers which

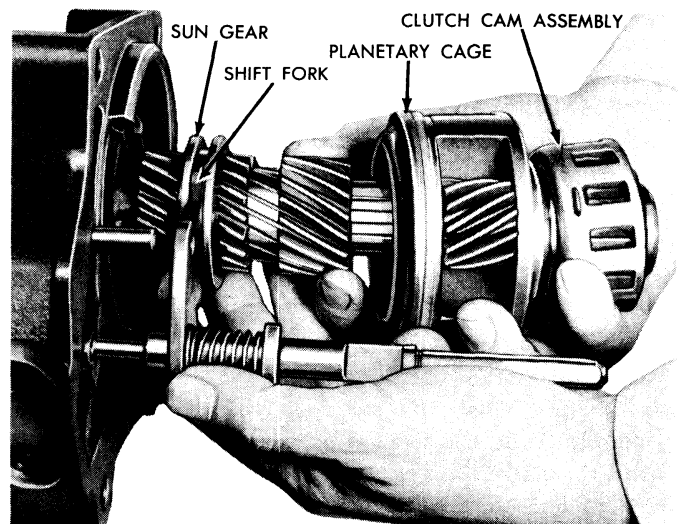

3195

Fig. 29—Clutch, Planetary Gears, and Shift Rail Removal

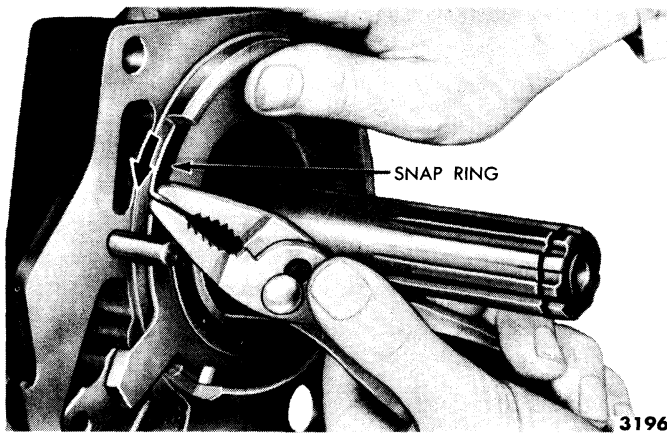

Fig. 30—Gear to Adapter Snap Ring Removal

secure the levers on the cam and shaft units, then remove the levers from the shafts and the cam and shafts from the case. Remove the lock plunger, spring, pin and poppet balls from the case. Make sure all input shaft pilot bearing rollers (15) are removed from the case. Remove the drain and filler plugs. Remove the shift lever shaft oil seals from the case.

Remove the snap ring which secures the input shaft bearing on the shaft, then press the bearing and oil baffle from the input shaft. The synchronizer unit may be disassembled by removing the blocking rings (the front ring may have been removed with the input shaft), and the sleeve from the hub. Remove the three inserts and the two snap rings from the synchronizer hub.

d. Cleaning and Inspection.

Clean and inspect the transmission unit parts in the same manner as for the conventional transmission. Clean all overdrive parts thoroughly.

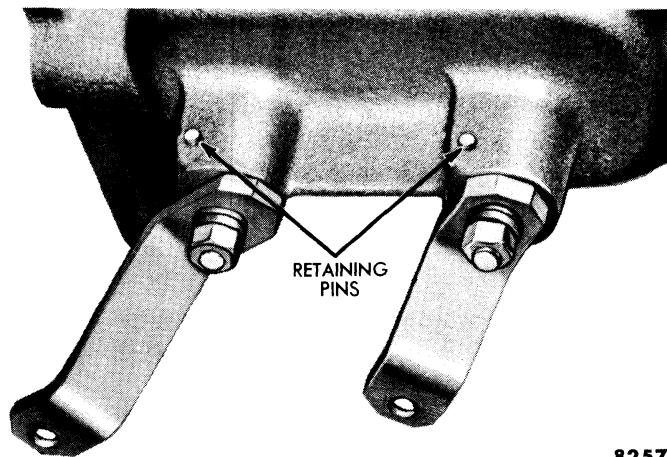

Fig. 31—Shift Lever Shaft Retaining Pins

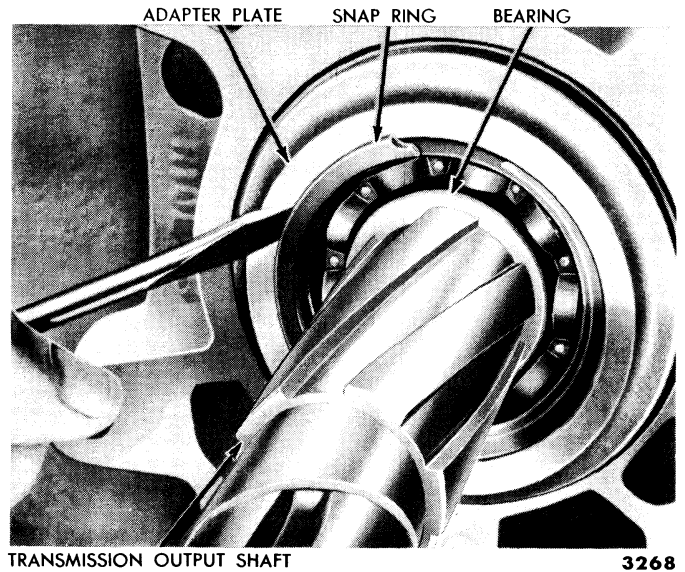

Fig. 32—Output Shaft Bearing Snap Ring Removal

Check the balk ring tension, as shown in fig. 34, for a pull of 3½-5½ pounds. The reading on the scale should be taken while the balk ring is turning, as the initial effort required to start the ring turning may be considerably higher than the specified pull. Replace the assembly if the tension is not within specifications.

Check the free-wheel clutch outer race for a worn or "chattered" inner surface. If the surface is worn, the overdrive mainshaft must be replaced. Check the clutch rollers for cracks and wear. Replace the complete set of rollers (12) if any are cracked or worn.

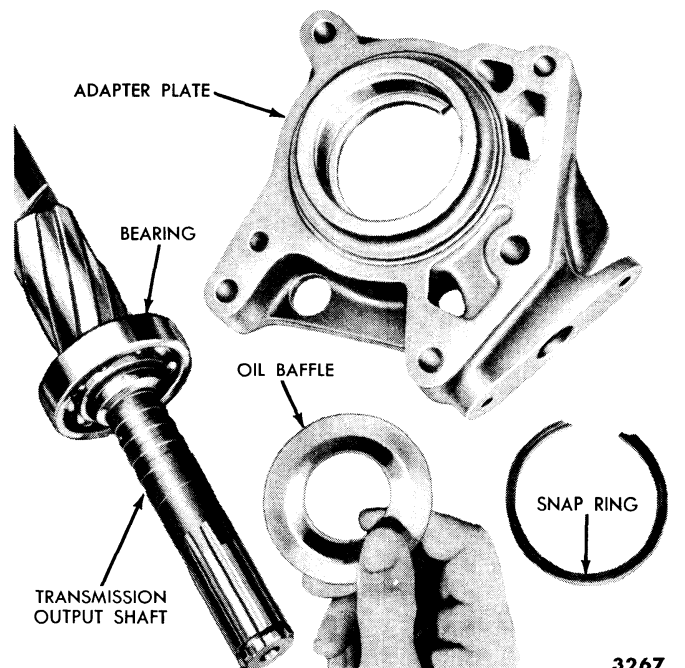

Fig. 33—Output Shaft and Adapter Plate—Disassembled

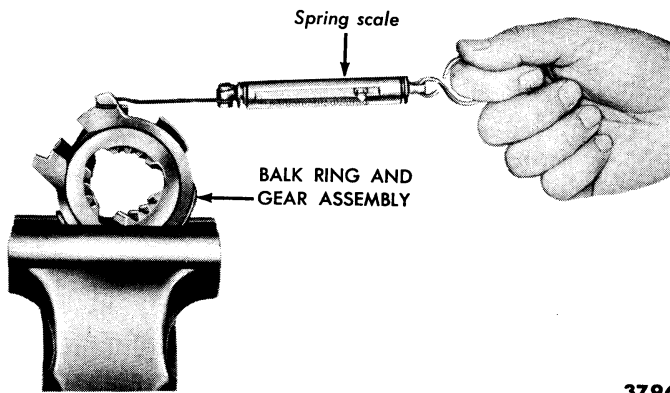

Fig. 34—Balk Ring Tension Check

3796

e. Assembly.

Always use new gaskets, lock washers, oil seals and gasket sealer during assembly. Apply a thin coating of lubricant on all parts before installation, to provide initial lubrication and prevent damage. Install new shift lever shaft oil seals, with tool 7688-N, with the lip of the seal toward the inside of the case. Be certain the seals bottom in the counterbores of the case and are not cocked in the bores.

Carefully install the intermediate and high shifter fork shaft and cam assembly in the case. Insert the plunger, spring, and pin in the bore of the case. Install the low and reverse shaft and cam assembly, then install the levers on the shafts with nuts and new lock washers.

Install a poppet ball in the plunger at the low and reverse end of the plunger, then push the low and reverse cam toward the poppet ball far enough to hold the ball in place in the neutral notch. The ball must seat in the notch of the cam. Move the intermediate and high cam toward the side of the transmission case, install the second poppet ball in the plunger, and pull the cam back to its normal position to hold the poppet ball in the neutral notch (fig. 35).

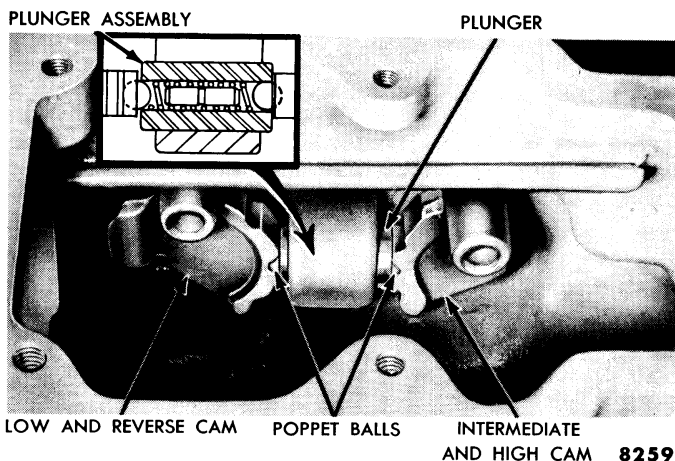

8259

Fig. 35—Cam and Poppet Ball Assembly

Install the shaft retaining pins (fig. 31).

In order to assure positive shifting and eliminate the possibility of engaging more than one set of gears at the same time, the clearance between the ramp of one cam and the plunger must be checked.

Shift one of the shaft cams to the neutral position. Position the other cam into a simulated gear engagement so the poppet balls seat in the respective cam notches. Check the clearance between the cam ramp and the plunger with a feeler gauge. The clearance should be 0.001-0.007 inch.

If the clearance is not within limits, install a new plunger of the proper length to provide the specified clearance.

Insert the pilot tool (T55P-7111-A) in the cluster gear, then install the cluster gear bearings and spacer in the gear. Use cup grease to hold the bearings and bearing retainers in the cluster gear bore. Apply a thin coating of grease to the gear side of the thrust washers, then properly position the washers at each end of the pilot shaft. Carefully position the cluster gear assembly in the transmission case, then check the cluster gear end play between the two thrust washers. If the end play is not within 0.005-0.018 inch, install new thrust washers.

Install the reverse idler gear in the transmission case with the longest offset end of the gear toward the front of the transmission. Insert the idler shaft in place with the lock notch in the shaft aligned with the notch in the countershaft.

Install the rear output shaft bearing on the shaft, then install the bearing snap ring. Be sure the snap ring seats solidly in the groove. Place the oil baffle on the bearing, then install the shaft and bearing assembly in the adapter housing. Install the snap ring which secures the bearing in the adapter housing.

Install the first and reverse gear on the shaft with the shifter fork groove towards the front of the transmission. Install the intermediate gear on the shaft with the notched hub towards the front end of the transmission.

Assemble the synchronizer unit by installing the two snap rings on the hub. Place the three inserts in position on the hub, using cup grease to hold them in place. Install the intermediate and high sleeve on the hub so the etched lines on the rear of the hub and the sleeve are in alignment to assure proper fit.

Install the synchronizer unit on the shaft with the blocking rings in place. Secure the synchronizer unit on the shaft with the snap ring seated solidly in place. Install the shifter forks in the cams inside the transmission case. The low and reverse fork (small fork) is positioned with the offset in the fork toward the front of the transmission (fig. 36).

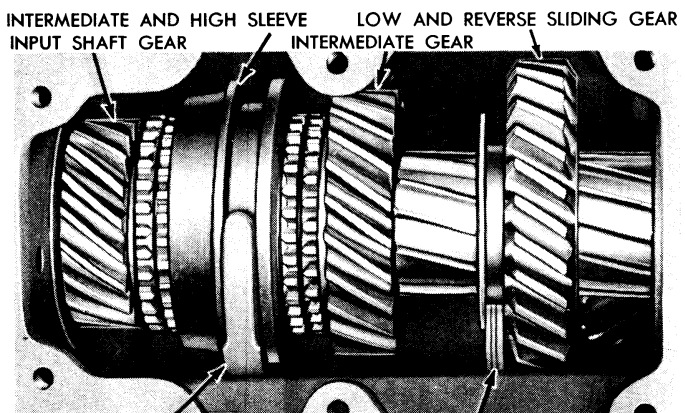

Fig. 36—Output Shaft Assembly Installation

Apply a thin coating of gasket sealer on a new adapter plate gasket, then position the gasket on the case.

Install the adapter plate and transmission output shaft assembly in the transmission, and secure the adapter plate to the transmission with the short cap screw.

Slide the oil baffle on the input shaft, press the bearing on the shaft, then install the snap rings in the shaft groove and in the bearing groove. Coat the input shaft bearing rollers with cup grease, then insert the rollers into the recess in the end of the input shaft. Place the synchronizer blocker ring on the input shaft, then position the input shaft assembly in the transmission case. Install the input shaft bearing retainer gasket and retainer.

Remove the adapter plate to transmission cap screw. Rotate the adapter plate until it clears the countershaft bore. Raise the countershaft with tool 7113-N until the cluster gear bore is aligned with the countershaft holes in the case.

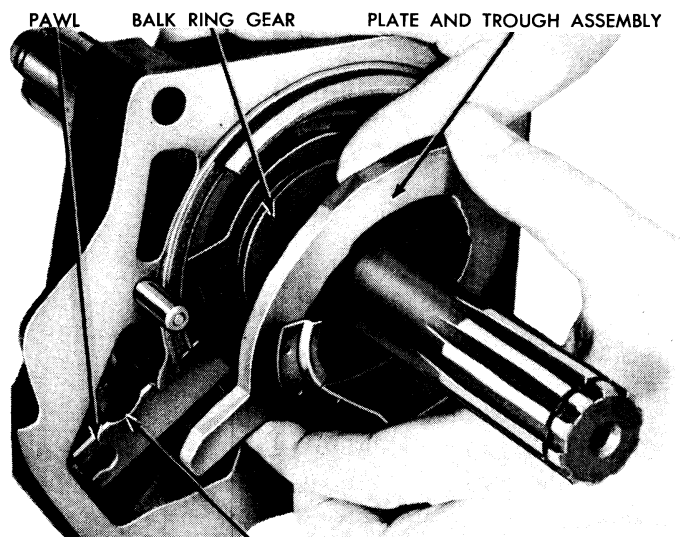

Fig. 37—Control Plate, Pawl, and Plate and Trough Assembly Installation

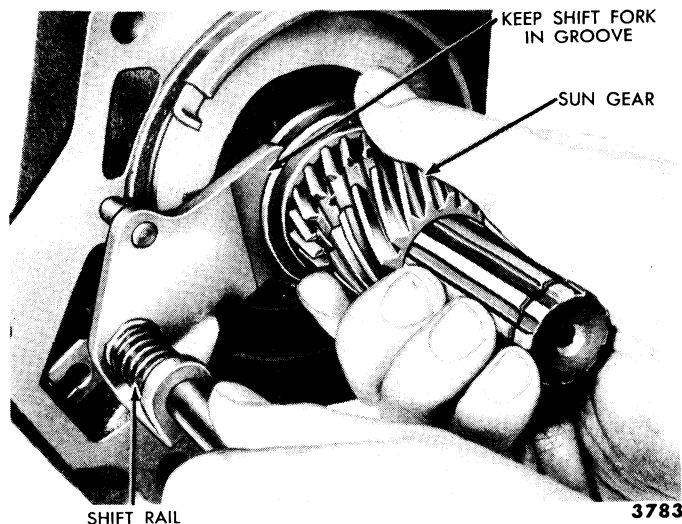

Fig. 38—Sun Gear and Shift Rail Installation

Drive the dummy shaft out of the cluster gear with the countershaft. Position the countershaft so the lock-plate notch is aligned with the notch in the idler shaft, then install the lock plate. Install the adapter plate to transmission case cap screw.

The balk ring gear assembly should be installed with the balk ring side out. Install the pawl with the machined recess in line with the shift rail hole, then install the plate and trough assembly (fig. 37).

Install the snap ring to secure the plate and trough assembly to the adapter. Install the shift rail and sun gear at the same time (fig. 38). Position the shift fork on the sun gear, then install the snap rings.

Install the planetary cage and the free wheeling clutch cam. Secure the clutch cam to the cage with the large retainer clip. Secure the clutch cam to the output shaft with the small retainer clip (fig. 39).

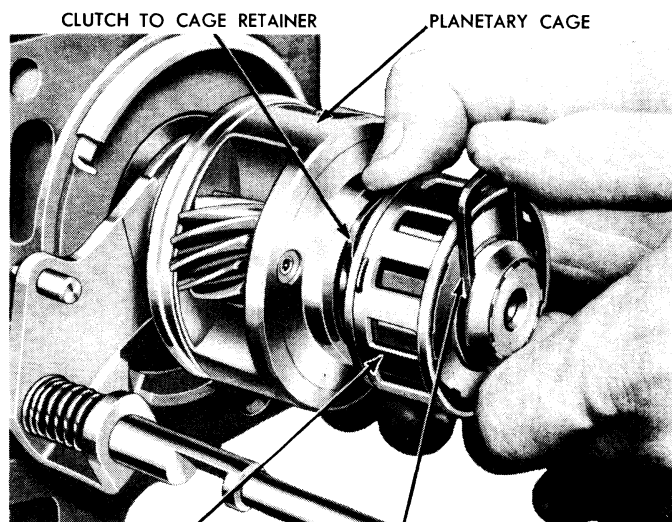
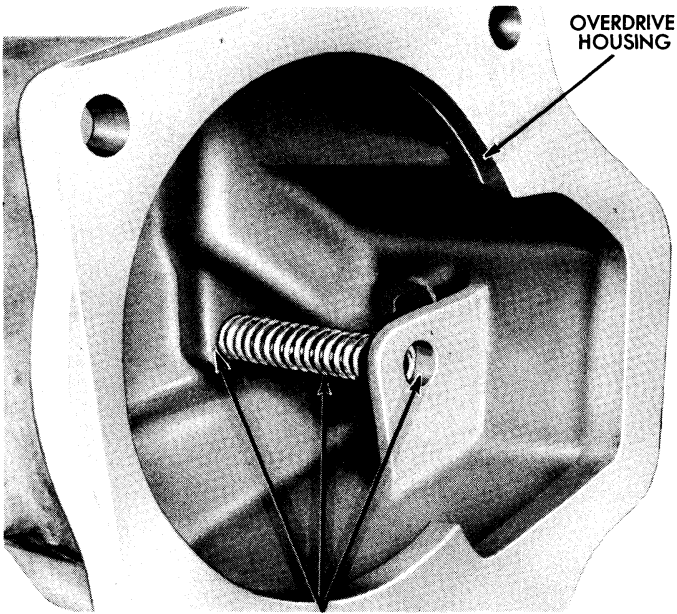

Fig. 39—Planetary Cage, Clutch Cam, and Retainers Installation



3702
Fig. 40—Shift Rail Spring Installation

Rotate the unit to a vertical position. Dip the rollers in grease, and install them in the clutch cam slots.

Position the ring gear on the overdrive mainshaft, then install the snap ring. Press the mainshaft bearing on the shaft. Install the key in the keyway in the mainshaft. Slide the speedometer driving gear on the mainshaft, then install the snap ring. Slide the overdrive mainshaft carefully over the free-wheel clutch. Be sure no rollers drop out when the shaft is installed. A twist of the shaft will set the rollers and permit the shaft to seat easily.

Install the manual control shaft in the overdrive housing. Align the shift rail spring with the hole in the overdrive housing (fig. 40).

Position a new gasket on the transmission case, then slide the housing over the overdrive mainshaft, spreading the snap ring in the housing as it slides over the shaft. If the snap ring will not go into its slot in the shaft, it may be necessary to pry the shaft upward, working through the governor hole in the housing (fig. 41).

CAUTION: *Be careful not to damage the governor mounting threads while prying the mainshaft upward.*

7. GEAR SHIFT LINKAGE

Two types of gear shift linkages are used on cars equipped with the conventional 3-speed or overdrive transmissions. All cars except the Thunderbird have a remote-type shift control mounted on the steering column. The Thunderbird is equipped with a floor-mounted gear shift.

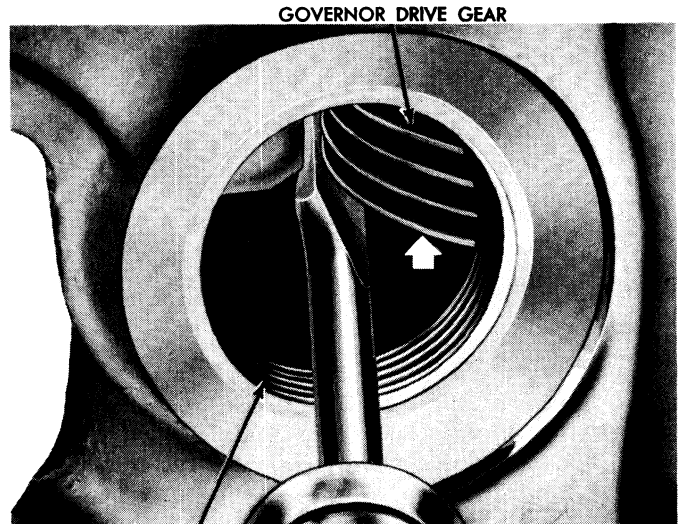

Fig. 41—Prying Overdrive Output Shaft

Engage the shift rail lever by pushing it inward. The lever is correctly engaged when a spring load is apparent as the lever is turned. Install the pin to retain the shaft. Install the overdrive housing to transmission case mounting bolts, and tighten them to 37-42 foot-pounds torque. Install the snap ring cover plug. Install the overdrive mainshaft bushing in the overdrive housing with tool T52L-7000-HAE, then install the seal with tool 7052-N.

Install the governor. Install the rubber protecting boot over the governor.

Rotate the solenoid $\frac{1}{4}$ turn from normal position so the ball on the solenoid stem can engage the pawl.

NOTE: *The ball on the end of the solenoid must be engaged in a slot in the pawl. If the solenoid is properly installed it cannot be removed unless it is rotated $\frac{1}{4}$ turn.*

Install the drain plug, fill the transmission and overdrive with lubricant, then install the filler plug.

f. Installation.

Install the overdrive and transmission assembly on the engine.

Install the overdrive control cable assembly on the transmission. Connect the solenoid and governor wires.

The remote-type gear shift lever (fig. 42) is spring loaded downward to reduce the possibility of shifting to reverse when shifting from first to second gear. It is necessary to lift up on the lever before shifting to first or reverse gears.

The motion of the gear shift lever assembly is trans-

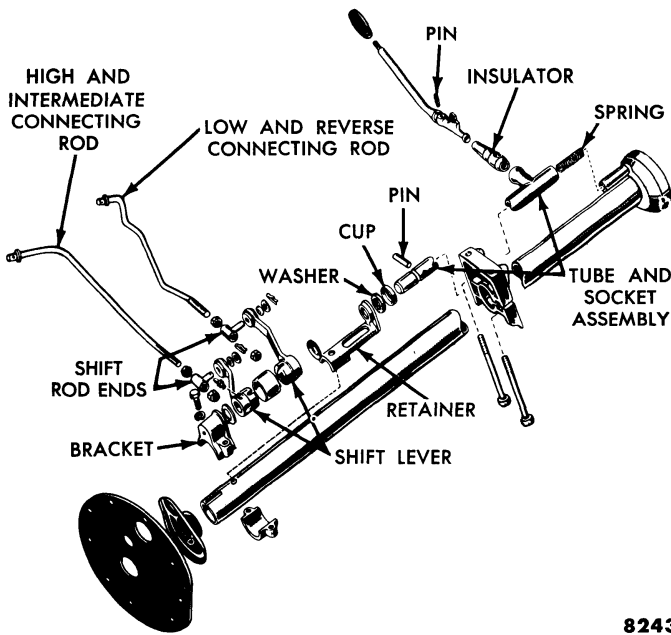

Fig. 42—Gear Shift Linkage—Conventional Cars

8243

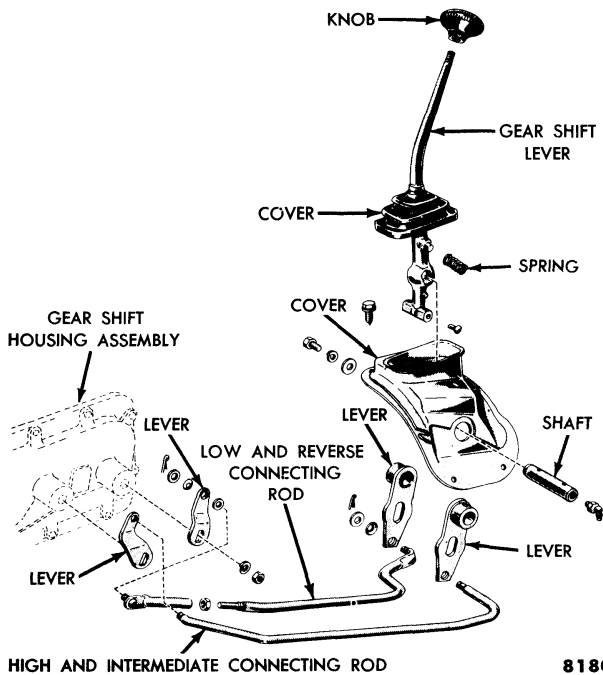

Fig. 43—Gear Shift Linkage—Thunderbird

8180

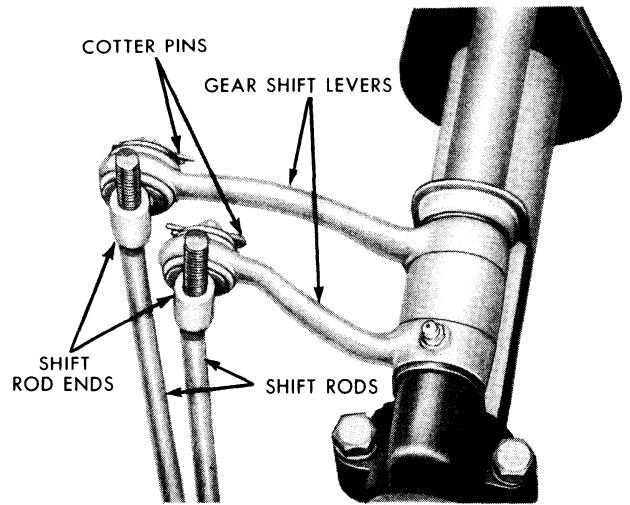

Fig. 44—Gear Shift Lever Adjustment

2509

ferred to the shift lever assemblies through the gear shift tube and socket assembly. The shift levers at the steering column are connected to the shift levers of the transmission gear shift housing by connecting rods. The connecting rod ends are threaded onto the connecting rods to provide a means for adjusting the gear shift linkage.

The Thunderbird gear shift lever (fig. 43) is mounted on the top left side of the tunnel in the floor. The shift rods are connected to the gear shift lever at one end and to the levers on the transmission gear shift housing at the other end.

a. Remote-Type Linkage Adjustment.

When shifting gears becomes difficult, the gear shift linkage should be adjusted.

Place the gear shift lever in the neutral position. Remove the cotter pins, flat washers, and spring washers from the shift rod ends (fig. 44), then pull the rod ends out of the gear shift levers. Rotate the rod ends either clockwise or counterclockwise enough to place the gear-shift levers in the same plane when the rod ends are assembled to the levers. In this position, the gear shift lever can be moved upward or downward in the neutral position without binding.

Position the shift rod ends in the gear shift levers, then install the spring washers, flat washers, and new cotter pins.

Part TWO

CHASSIS

Chapter

II

Rear Axles and Drive Lines

Section	Page
1 Trouble Shooting	141
2 Cleaning and Inspection	142
3 Banjo Housing Hypoid Rear Axle	143
4 Integral Housing Hypoid Rear Axle	152
5 Drive Lines	158

All Ford car rear axles are of the semi-floating type with hypoid ring and pinion gears and a two-pinion differential assembly. The rear axle used on conventional models has a banjo housing with removable differential

carrier. The Station Wagon, Courier, Thunderbird, and Police Interceptor rear axles have an integral-type housing and differential carrier.

1. TROUBLE SHOOTING

A rear axle should not be disassembled until a thorough diagnosis is first made of the trouble and symptoms observed during the operation of the car.

No attempt is made in this section to provide detailed repair procedures to make the necessary corrections. The repair procedures are given in detail in other axle sections of this manual.

a. Rear Axle.

Unusual noises are usually the first sign of trouble in the rear axle. However, tire noise, wheel bearing noise, body rumble, muffler damage, and rubbing brake shoes are often diagnosed as rear axle trouble. Therefore, it is important that all of the above conditions be eliminated to obtain a correct diagnosis of the rear axle noise.

Road test the car. Inflate the tires to the correct pressures. Drive the car on a smoothly paved road, preferably an asphalt or black-top road to minimize tire noise. Drive the car far enough to warm the axle lubricant to its normal operating temperature.

A continuous axle noise may be caused by the axle or by unevenly worn tires. To isolate the cause, drive the car on soft ground. If the noise is eliminated, it is caused by the tires. Change or closely match the tires as required.

If the noise continues as a heavy-pitched rumble, which increases as the car speed increases, the wheel bearings, the drive pinion bearings, or the differential bearings may require adjustment. The condition may

also indicate insufficient lubricant in the differential.

“Coast noise” will be more evident when the car coasts from a high speed (50 m.p.h.) to a low speed (15 m.p.h.) with the clutch engaged and the throttle closed. If the noise is heavy and irregular, check the condition of the front pinion bearing, and check drive pinion bearing preload. Bearings improperly adjusted, worn, scored, or rough will aggravate axle noises. If the noise is continuous on coast or drive, the drive pinion and drive gear are worn or are out of adjustment.

Excessive backlash in the axle driving parts may be caused by worn axle shaft splines, loose axle shaft drive flange nuts, loose U-joint companion flange mountings, excessive backlash between the drive pinion and drive gear, excessive backlash in the differential gears, or differential bearings worn or out of adjustment.

Check tooth contact, backlash, and differential side bearing preload. Make repairs or adjustments or replace parts as required to correct any abnormal conditions.

b. Drive Line.

Excessive noise or vibration may be caused by lack of lubrication, worn universal joint bearings, and sprung or damaged drive lines. Make the necessary repairs as required.

In some cases, loose or broken fenders, body hold-down bolts, or brackets should be checked as a source of noise. Repair, tighten, or replace the parts as required.

2. CLEANING AND INSPECTION

The cleaning and inspection procedures given in this section apply generally to all car rear axles.

a. Cleaning.

Soak all differential parts, except the bearings, in a cleaning solvent. Clean the axle housing. All dirt, old lubricant, and gasket material should be removed from all the axle parts with a stiff brush.

The bearings should be cleaned thoroughly. Small

particles of grit left between the bearings and the races can cause excessive wear and premature bearing failure. Soak the bearings in clean kerosene or other bearing cleaning fluid. Do not use gasoline. Parts cleaned in gasoline have a tendency to rust. Hold the bearing races to prevent rotation, then slosh the bearings in the cleaning fluid to remove as much grit as possible. Brush the bearings with a soft-bristled brush until all particles of grit have been removed. Rinse the bearings in clean fluid, then dry them with moisture-free, compressed air.

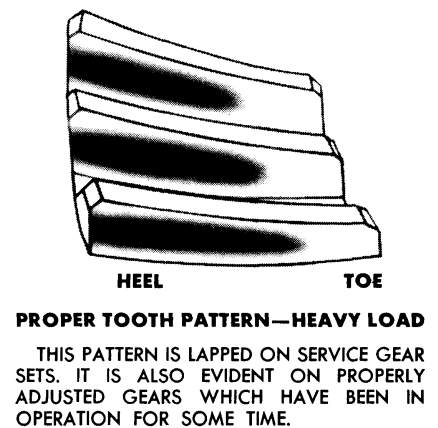
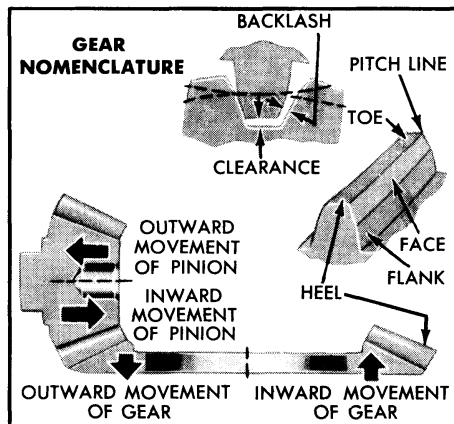
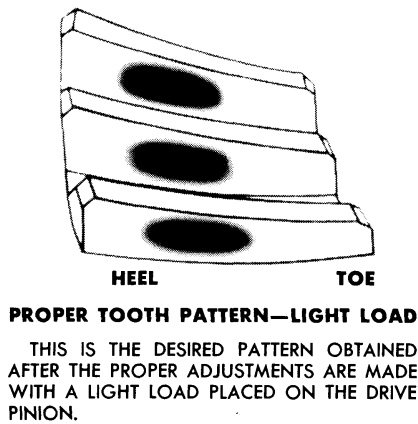

PATTERN CHANGE WITH DRIVE GEAR MOVEMENT

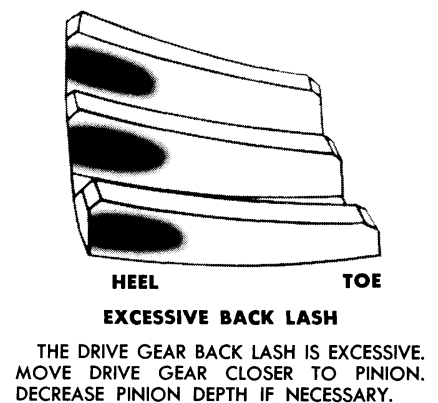
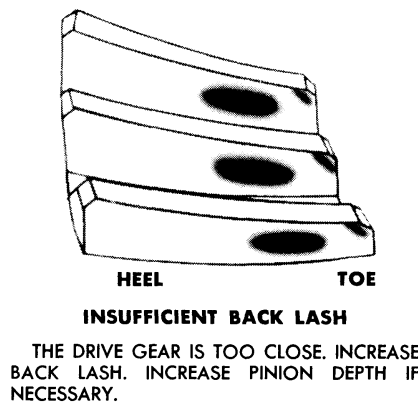
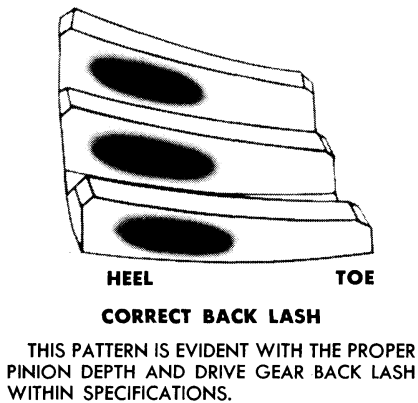

PATTERN CHANGE WITH PINION MOVEMENT

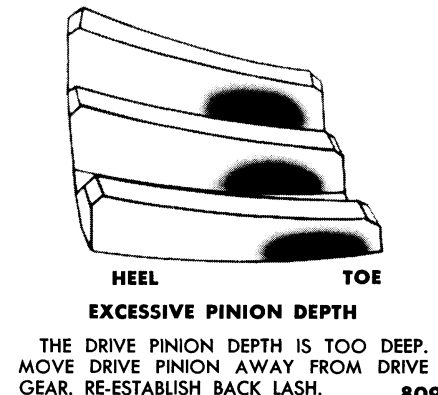
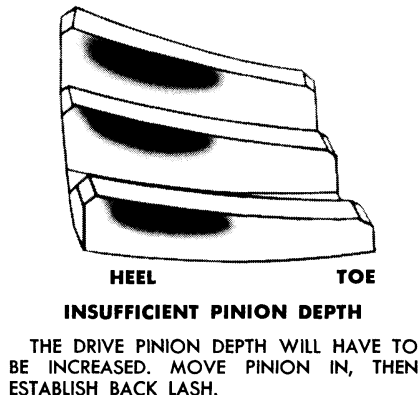
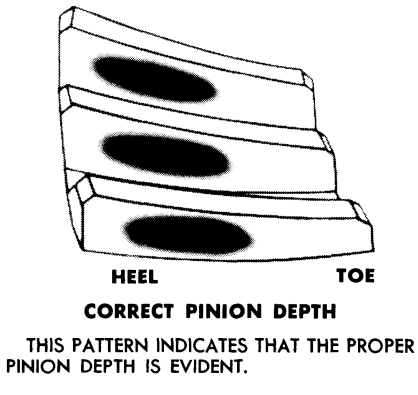

Fig. 1—Gear Tooth Contact Pattern Chart

Do not spin the bearings while drying.

b. Inspection.

Visually inspect all rear axle parts for excessive wear or damage. Excessive wear on any part can often be found by comparing the worn part with a new part.

(1) **BEARINGS AND CUPS.** Examine the bearings and cups for cracks, chips, discoloration due to overheating, excessive wear, or other damage. Lubricate the bearings and check for roughness by turning the outer race by hand. Inspect the large ends of the tapered rollers for wear.

Replace all damaged or worn bearings and cups. After the bearings have been inspected, coat them with rear axle lubricant, then wrap each bearing in a clean cloth until ready to use.

(2) **AXLE HOUSING.** Inspect the axle housing for broken welds, missing or loose rivets, damaged threads or studs, and a bent or cracked housing.

The axle housing may be inspected for a bent condition after the axle assembly has been removed from the car. First install the rear wheels, then install a telescopic-type toe gauge between the rear wheels. Hold the wheels stationary, then rotate the axle housing through 360° and note the readings on the gauge scale. No variations in the readings, while the housing is turning, indicates a straight housing. Variable readings on the gauge scale show that the axle housing is bent and should be replaced.

The spring seat welds should be inspected to be sure they are not broken. Repair or replace as required.

(3) **GEAR INSPECTION.** Check all of the rear axle gears for chipped, cracked, or worn teeth. Check the clearances between mating parts and check the thrust washer thickness.

(4) **AXLE SHAFT INSPECTION.** Inspect the axle shaft splines for twists, cracks, or wear. The axle shaft

should be inspected for torsional damage. Replace any axle shaft that has damaged splines or shows signs of torsional damage.

c. Gear Tooth Contact.

Rear axles should operate with a minimum of noise when the contact area between the drive pinion and ring gear teeth is adjusted properly. Adjustments make it possible to obtain the proper gear tooth contact.

During the axle disassembly, check the gear tooth pattern and backlash between the drive pinion and ring gears. These checks will help to determine the extent of repairs and parts replacement.

Before removing the differential assembly from the carrier, check the runout on the back face of the ring gear. If the runout exceeds 0.003 inch, remove the ring gear from the case, then check the runout on the face of the gear flange and gear pilot. If the runout still exceeds the specified limit, the differential bearings may be defective, or the differential case may be worn.

During the assembly of the axle, use the specified backlash as an approximate setting for the first gear tooth contact pattern. However, the backlash specification should not restrict any further adjustments that may be necessary to obtain the correct pattern. Always obtain a correct gear tooth contact pattern at the final setting of the gears regardless of the backlash specification.

NOTE: *New drive pinion and ring gear sets have a gear tooth contact pattern rolled on the gear teeth at the factory. When installing new gear sets, adjust the gears so that this pattern is duplicated at the final axle setting.*

Figure 1 shows examples of correct and incorrect gear tooth contact patterns, and outlines the adjustment procedures used.

3. BANJO HOUSING HYPOID REAR AXLE

A banjo housing hypoid rear axle (fig. 2) is used on all cars except the Station Wagons, Courier, Thunderbird, and Police Interceptor.

a. Construction.

The outer ends of the axle shaft tubes on the banjo housing are formed into flanges for attaching the brake carrier plates and the rear wheel bearing outer retainers. The rear spring seats are welded to the tubes. The housing rear cover is welded to the back of the housing.

The differential carrier is attached to the axle hous-

ing with studs and nuts. A gasket is installed between the carrier and the housing. The axle lubricant filler plug is located in the carrier. A vent assembly is installed on the axle housing.

On the 1956 axle a baffle, held in place by two housing bolts, directs lubricant to the differential side bearings (fig. 8). It is recommended that this baffle be installed on earlier models, whenever the carrier assembly is removed.

To install the baffle, drive out two housing bolts (one on each side of the top bolt). Position the baffle on the

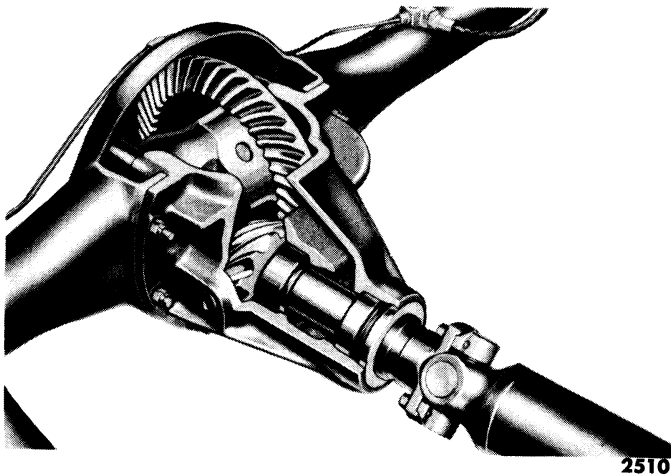

Fig. 2—Banjo Housing Hypoid Rear Axle

inner side of the mounting flange. Apply a sealer to the serrated part of the bolts removed and pull into place with flat washers and a nut.

The two-pinion differential assembly (fig. 3) and the drive pinion assembly are installed in the carrier, and are removed with the carrier assembly from the axle housing. Tapered roller differential bearings are pressed on the differential case hubs, and held in place by bearing caps which are bolted to the carrier. Adjusting nuts permit adjustment of the differential bearings. Thrust washers are used between the differential pinions and the case, and between the differential side gears and the case.

The drive pinion assembly is mounted in two opposed tapered roller bearings (fig. 2). The pinion bearing cups are pressed into the differential carrier. A bearing spacer is installed between the inner and outer pinion

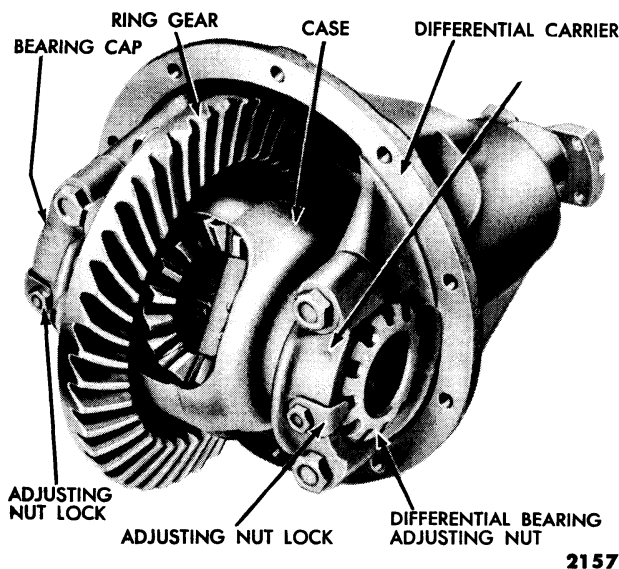

Fig. 3—Differential Assembly

bearings. A single-lip, spring-loaded oil seal is installed in the bore of the differential carrier at the outer end of the drive pinion.

Semi-floating axle shafts are mounted in heavy-duty, sealed ball bearings which are pressed on the axle shaft (fig. 4). The bearings are held in position by a retainer ring which is also pressed on the shaft. The axle retainer plate is bolted to the flange of the axle housing. The brake drums and wheels are mounted on the axle shaft flanges.

b. Axle Shaft Replacement.

The axle shafts may be replaced without removing the rear axle assembly from the car.

(1) **REMOVAL.** Remove the wheel and tire assembly, then remove the nuts that secure the brake drum to the axle flange. Remove the brake drum. Working through the hole provided in the axle shaft flange, remove the nuts that secure the brake plate to the axle housing. Pull the axle shaft assembly out of the housing as shown in fig. 5. Be careful not to dislodge the brake plate or damage the oil seal in the housing. Install one nut to hold the brake plate in place.

(2) **INSTALLATION.** If the original axle shaft is to be installed, check the rear wheel bearing and oil seal for wear before installation. Grasp the bearing outer race and "rock" it on the axle shaft, checking for looseness at the bearing oil seal. Visually inspect the bearing for lubricant leakage. If excessive looseness is evident or if an excessive quantity of lubricant appears on the bearing, replace the bearing. If the oil seal is damaged in any way or if the feather edge does not form a tight seal, replace the seal.

Remove the temporary nut holding the brake plate to the housing. Lubricate the bearing bore in the axle housing, clean the brake plate surface, then install new gaskets on each side of the backing plate.

Slide the axle shaft assembly into the axle housing,

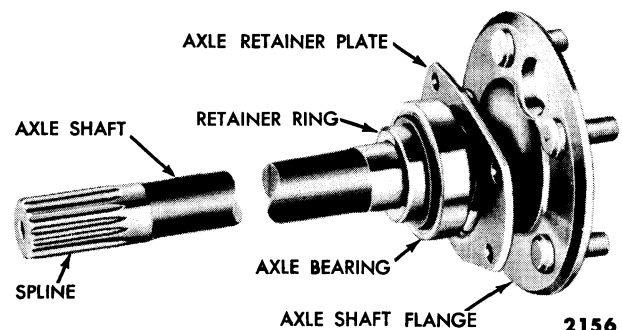

Fig. 4—Rear Axle Shaft Assembly

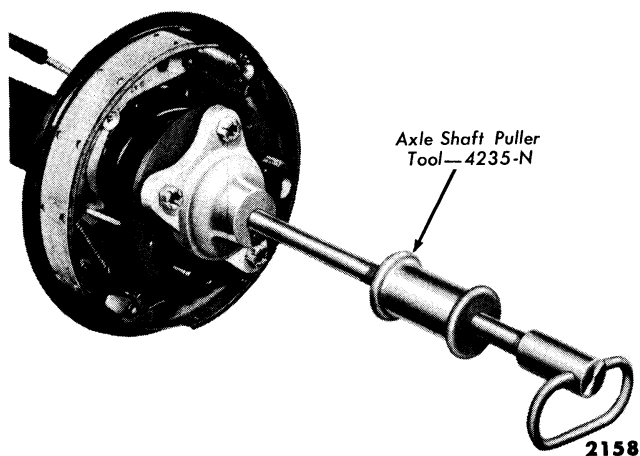

Fig. 5—Axle Shaft Removal

being careful not to damage the oil seal. Rotate the axle shaft until the splines of the shaft mate with the splines of the differential side gear. Push the axle shaft assembly into the housing until the axle bearing is tight against the shoulder in the housing. Position the axle shaft retainer plate gasket and plate on the rear axle housing. Install the axle shaft to housing bolts and lock nuts. Tighten the nuts to 30-35 foot-pounds torque. Position the brake drum on the axle flange then install the nuts. Install the tire and wheel assembly.

c. Drive Pinion Oil Seal Replacement.

The pinion oil seal may be replaced without removing the differential carrier from the car.

Disconnect the drive shaft at the rear universal joint. Mark the position of the universal joint flange, nut, and pinion shaft with a punch to aid in obtaining the same pre-load when assembling the unit. Remove the universal joint flange nut and washer. Remove the flange from the pinion shaft with the puller shown in fig. 6. Install an oil seal puller and pull the pinion oil seal out of the carrier (fig. 7).

Check the lubricant drain-back passage in the carrier, and the axle housing vent, for obstructions. Clean these parts if required. Inspect the carrier bore and the surface of the universal joint flange contacted by the oil seal, for nicks. Remove all nicks with a file or stone. Place a coating of oil resistant sealer on the inside of the seal bore in the carrier casting to prevent leakage.

NOTE: Soak new oil seals in oil for one-half hour before installation.

Position the new drive pinion oil seal in the carrier bore. Install the oil seal with the tool shown in fig. 16. The seal should be flush to $\frac{1}{64}$ inch below the end of the bore. Install the universal joint flange on the pinion

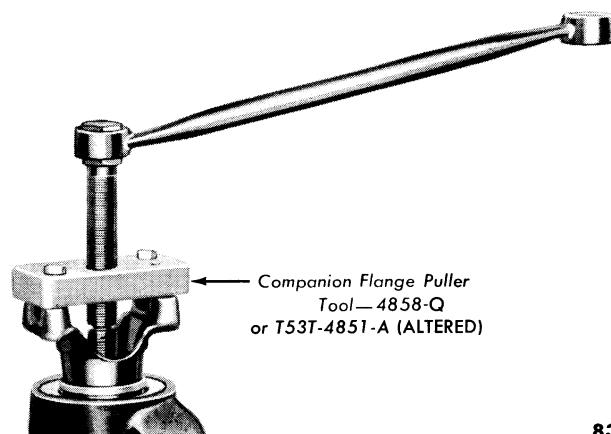

Fig. 6—Universal Joint Flange Removal

shaft (fig. 13). Install the washer and nut on the pinion shaft, then tighten the nut until it is tight on the pinion shaft with the punch marks on the nut and pinion shaft aligned. Connect the drive shaft at the rear universal joint.

d. Differential Carrier Removal and Disassembly.

The removal, disassembly, adjustment, and installation procedures for the differential carrier, differential case, and drive pinion are included below.

(1) **DIFFERENTIAL CARRIER REMOVAL.** Drain the lubricant from the rear axle housing. Remove the carrier to housing nuts (fig. 8). Remove the carrier assembly from the axle housing.

(2) **DIFFERENTIAL CASE REMOVAL AND DISASSEMBLY.** Before removing the differential case from the carrier, clean the carrier assembly thoroughly. Inspect the drive pinion and the drive gear and case assembly for end-play. Inspect the gear tooth pattern to determine if the gears are worn, defective, or out of adjustment. Check and note if excessive backlash or drive gear runout is evident.

Mark the differential bearing caps and carrier supports with matching numbers to ensure proper assem-

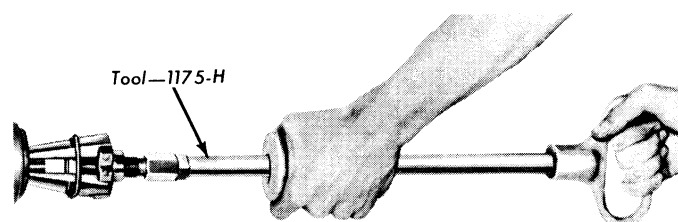

Fig. 7—Drive Pinion Oil Seal Removal

bly. Remove the differential adjusting nut locks, bearing caps, and adjusting nuts. Lift the differential assembly out of the carrier. Remove the differential bearings with the bearing puller shown in fig. 9.

Remove the cap screws which attach the drive gear to the differential case, then tap the drive gear off the case with a soft hammer. Drive the pinion shaft locking pin out of the case with a drift, working from the drive gear side of the case. Remove the pinion shaft from the case, then remove the differential pinions, the differential side gears, and the thrust washers.

(3) **DRIVE PINION REMOVAL AND DISASSEMBLY.** Remove the universal joint flange nut and washer, then pull the flange off the drive pinion (fig. 6). Lift the drive pinion, rear bearing, and bearing spacer out of the carrier.

NOTE: *With some ratios it will be necessary to remove the oil seal and front pinion bearing cone before removing the pinion gear.*

Remove the oil seal using the tool shown in fig. 7. Lift the oil slinger and front bearing out of the carrier.

Remove the rear bearing from the drive pinion with tool 4621-N or 4621-E. Remove the shim from the drive pinion. Note the total thickness of the shim for reference during assembly.

Remove the pinion bearing cups from the carrier with the tool shown in fig. 10. If the tool is not available, drive the bearing cups out of the carrier with a soft drift and a hammer.

e. Differential Carrier Assembly.

If replacement of the drive gear or the drive pinion is necessary, both parts must be replaced, as the gears are manufactured only in matched sets.

When the differential case is replaced, be sure the new case is the same as the case being replaced. Refer to Table 1 for case identification.

Coat all differential parts with axle lubricant before installation, and always install new gaskets and oil seals.

(1) **DRIVE PINION INSTALLATION AND ADJUSTMENT.** Two methods of selecting the shim for the drive pinion are provided. One method makes use

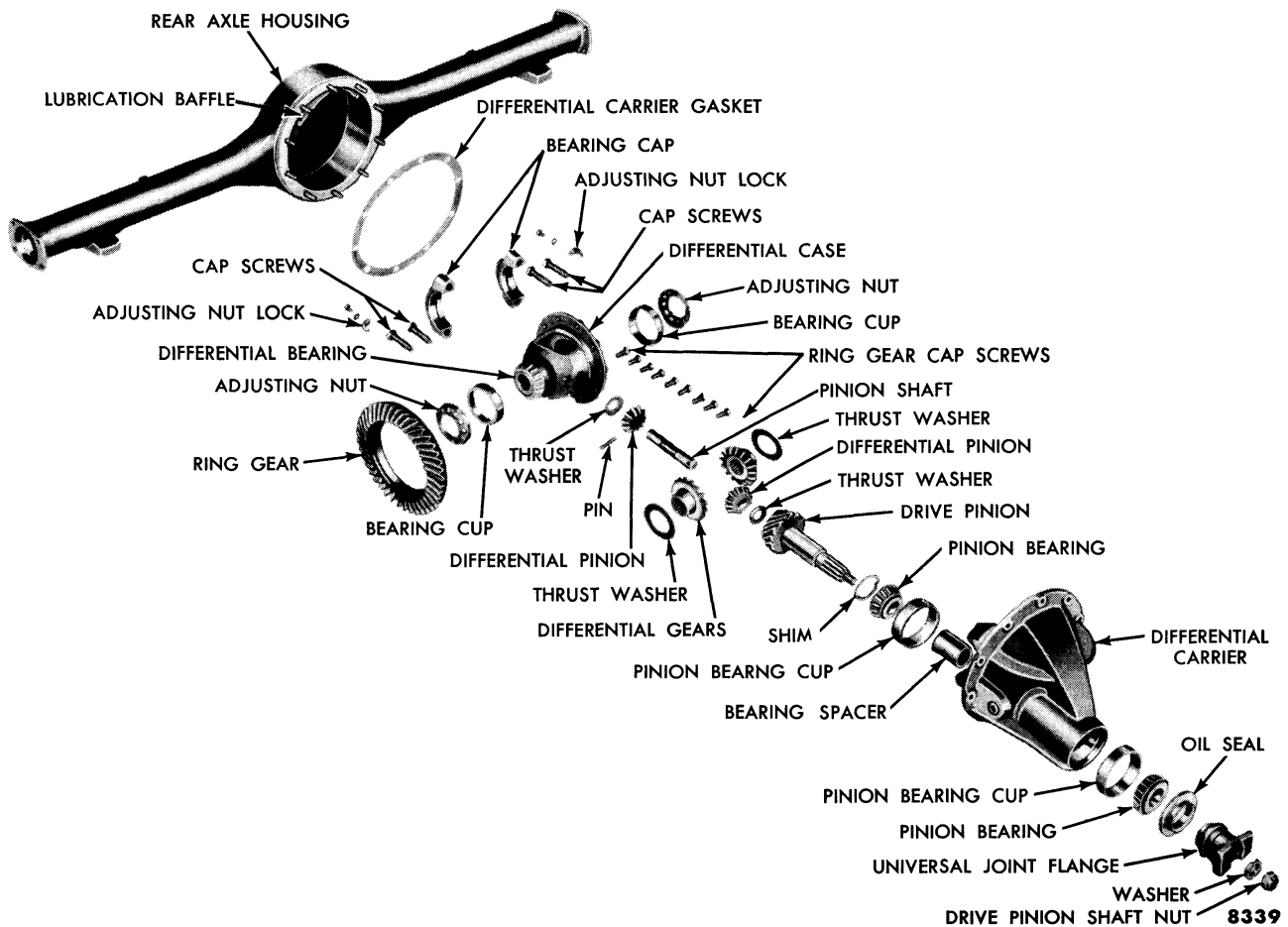
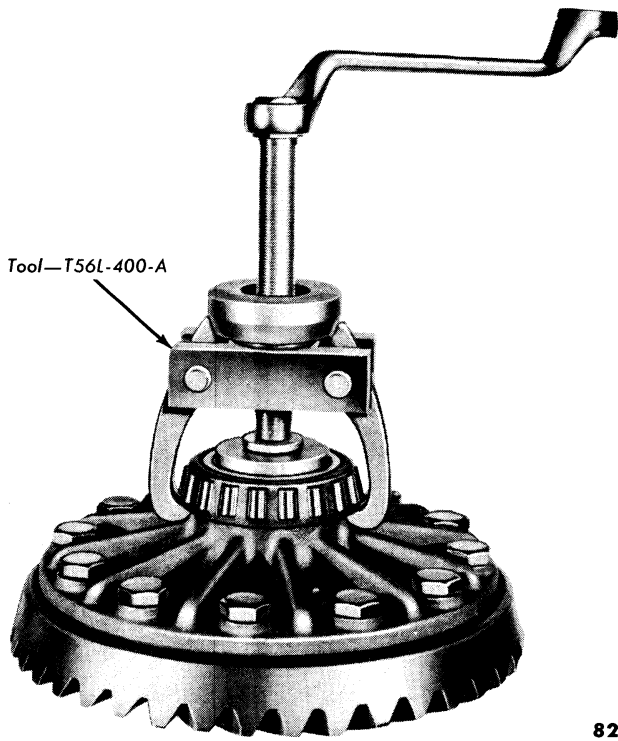

Fig. 8—Rear Axle Disassembled



8224

Fig. 9—Differential Bearing Removal

of a master pinion tool. The other method is based on tooth pattern.

NOTE: The final test for the shim required in both methods is the gear tooth contact pattern.

(a) MASTER PINION TOOL METHOD. Make sure the bores in the carrier are free of burrs and metal chips,

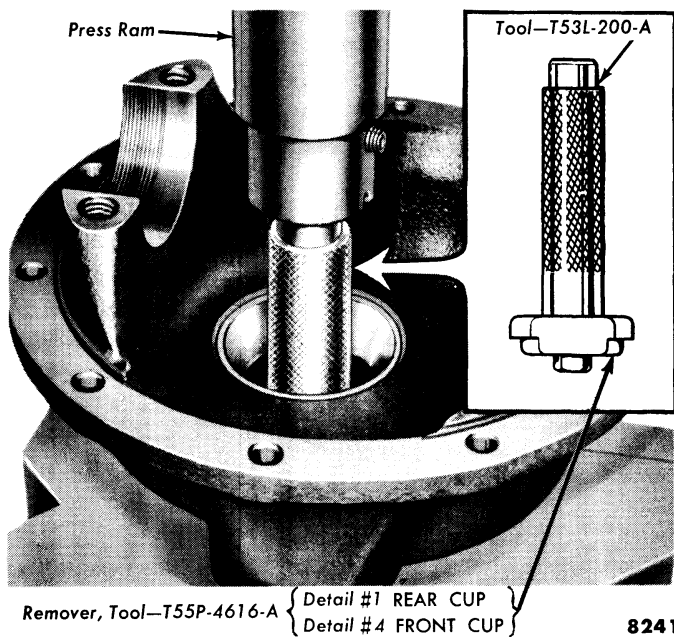

8241

Fig. 10—Drive Pinion Bearing Cup Removal

Table 1—Ratio, Drive Gear and Differential Case Identification

Gear Teeth	Drive Gear Diameter	Ratio	Transmission Application	Engine Type	Differential Case Color
37 Drive 9 Pinion	8¼	4.11:1	Overdrive	6-cylinder	Black
35 Drive 9 Pinion	8¼	3.89:1*	Conventional	6-cylinder	Black
			Overdrive	8-cylinder (272 Engine)	
34 Drive 9 Pinion	8¼	3.78:1*	Conventional	8-cylinder (272 Engine)	Black
32 Drive 9 Pinion	8¼	3.55:1*	Fordomatic	6-cylinder 8-cylinder (optional with 272 engine)	Red
29 Drive 9 Pinion	8¼	3.22:1	Fordomatic	6-cylinder 8-cylinder (272 and 292 engines)	Gray
35 Drive 9 Pinion	8½	3.89:1	Overdrive	8-cylinder (292 Engine)	Black
34 Drive 9 Pinion	8½	3.78:1	Conventional	8-cylinder (292 Engine)	Black
32 Drive 9 Pinion	8½	3.55:1	Optional with Fordomatic	8-cylinder (292 Engine)	Red

*Service replacement gears will be 8½ inch diameter.

then install the drive pinion bearing cups in the carrier using the tool shown in fig. 11.

The same pinion depth gauges are used on the 1956 axles as on earlier models, but the following cautions

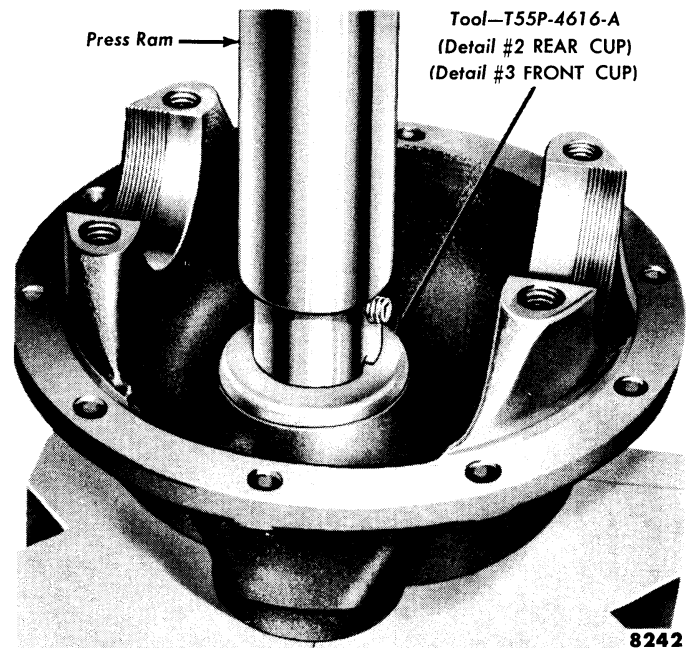

8242

Fig. 11—Drive Pinion Bearing Cup Installation

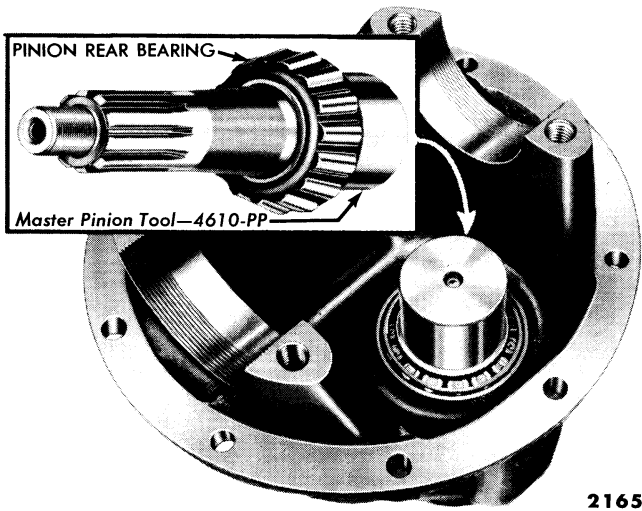

Fig. 12—Drive Pinion Adjustment Tool Installation

must be observed:

Adapter rings must be used with the depth gauges (fig. 15), because the differential bearing pocket diameters are $\frac{1}{8}$ inch larger than those of earlier models.

A spacer (approximately $\frac{1}{8}$ inch) must be inserted between the universal joint flange and the front pinion bearing, when the master pinion (fig. 12) is installed in the carrier casting. This spacer is required, because the pinion rear bearing cup is approximately 0.108 inch deeper in the carrier casting than in earlier models. If the spacer is not used, the universal joint flange washer will bottom on the master pinion spline before the flange has moved far enough to pre-load the bearings.

Micrometer readings (Table 2) are different than those for earlier models, because of the new pinion rear

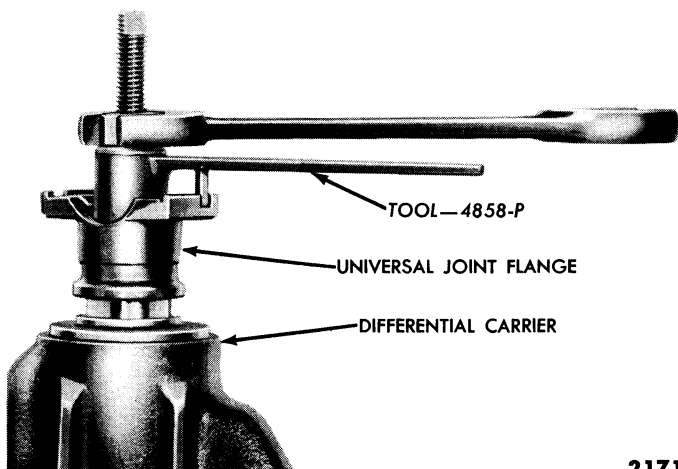

Fig. 13—Universal Joint Flange Installation

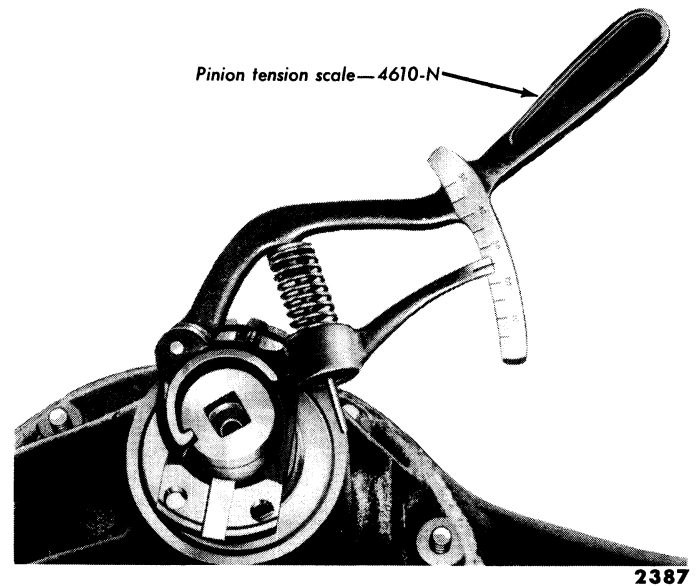

Fig. 14—Pinion Bearing Pre-Load Check

bearing location and the thinner pinion rear bearing shim.

Place the pinion rear bearing cone, which will be used in the final assembly, on the master pinion (fig. 12). Place the master pinion in the housing. Install the front bearing, $\frac{1}{8}$ inch spacer, universal joint flanges, washer, and nut. Hold the flange and tighten the nut to preload the bearings to 15-20 inch-pounds. The preload may be checked with the tool shown in fig. 14.

NOTE: *Alternately turn the drive pinion while tightening the nut to seat the bearings properly.*

Install the pinion depth gauge shown in fig. 15. Measure the distance between the depth gauge and the master pinion with a 2-3 inch micrometer. Remove the pinion depth gauge and the master pinion tool from the carrier.

Observe the number painted on the face of the pinion to be installed. With this number and the micrometer reading, select from Table 2 the total shim thickness requirement.

For example: A reading of 2.135 inches from tool 4610-P with a pinion marked "17" requires a 0.017 inch shim.

Shims of 0.010, 0.011, 0.012, 0.013, 0.014, 0.015, 0.016, 0.017, 0.018, 0.019, 0.020, and 0.021 inch thickness are available for service. Install the proper shim on the pinion shaft, then press the rear bearing on the pinion until it is seated against the shim.

Install the pinion assembly in the carrier, then install the bearing spacer and the front bearing. Place the oil

slinger and seal on the pinion shaft. Brush a thin coating of sealer on the outer diameter of the seal, then drive the oil seal into place with the tool shown in fig. 16. Install the universal joint flange with the tool shown in fig. 13, then install the flange washer and nut. Alternately turn the pinion while tightening the nut until the bearing preload is 18-24 inch-pounds (new bearings) or 13-18 inch-pounds (used bearings).

(b) **TOOTH PATTERN METHOD.** If the original drive pinion is being used, install the original shims on the drive pinion. If a new drive pinion is being installed, and the drive pinion marking is the same as on the old pinion, install the original shims. However, a thicker shim is necessary if the number on the pinion is greater, or a thinner shim pack is required if the number is smaller. For instance, if the old pinion was marked "15", and the new pinion is marked "17", install a 0.002 inch thicker shim pack. Conversely, a 0.002 inch thinner shim pack should be used if the new pinion is marked "13".

If the old bearings are to be used, increase the shim pack thickness by 0.002 inch. If the old shims are not available, use a shim pack 0.015 inch thick for a trial build-up. Install the shim pack, then install the drive pinion rear bearing.

Install the drive pinion assembly in the carrier, install a new bearing spacer, then install the pinion front bearing. Install the oil slinger on top of the front bearing. Brush a thin coating of sealer on the outer diameter of the seal, then drive the oil seal into place with the tool shown in fig. 16.

Install the universal joint flange with the tool shown in fig. 13. Install the flange washer and a new nut. Alternately turn the pinion while tightening the nut.

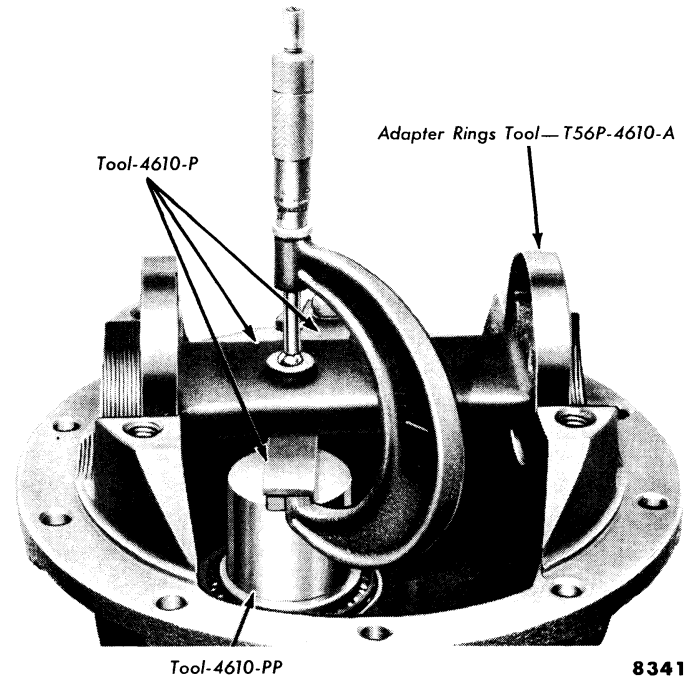

Fig. 15—Pinion Depth Adjustment Check

CAUTION: Do not damage the drive pinion bearing spacer by over tightening the drive pinion nut.

If new drive pinion bearings and a new oil seal have been installed, tighten the drive pinion nut until the bearing pre-load is 18-24 inch-pounds. If the old pinion bearings are used, tighten the drive pinion nut until the bearing pre-load is 13-18 inch-pounds.

(2) **ASSEMBLE DIFFERENTIAL.** Install the differential side gears, pinions, and thrust washers in the differential case. Install the pinion shaft and the pinion shaft lock pin. Position the drive gear (ring gear) on the case, install the drive gear cap screws, then tighten the

Table 2—Shim Requirements—1956 Axle Only

Micrometer Reading Tool 4610-P	PINION MARKING							Micrometer Reading Tool 4610-A
	12	13	14	15	16	17	18	
2.131	.008	.009	.010	.011	.012	.013	.014	2.631
2.132	.009	.010	.011	.012	.013	.014	.015	2.632
2.133	.010	.011	.012	.013	.014	.015	.016	2.633
2.134	.011	.012	.013	.014	.015	.016	.017	2.634
2.135	.012	.013	.014	.015	.016	.017	.018	2.635
2.136	.013	.014	.015	.016	.017	.018	.019	2.636
2.137	.014	.015	.016	.017	.018	.019	.020	2.637
2.138	.015	.016	.017	.018	.019	.020	.021	2.638
2.139	.016	.017	.018	.019	.020	.021	.022	2.639
2.140	.017	.018	.019	.020	.021	.022	.023	2.640
2.141	.018	.019	.020	.021	.022	.023	.024	2.641
2.142	.019	.020	.021	.022	.023	.024	.025	2.642
2.143	.020	.021	.022	.023	.024	.025	.026	2.643

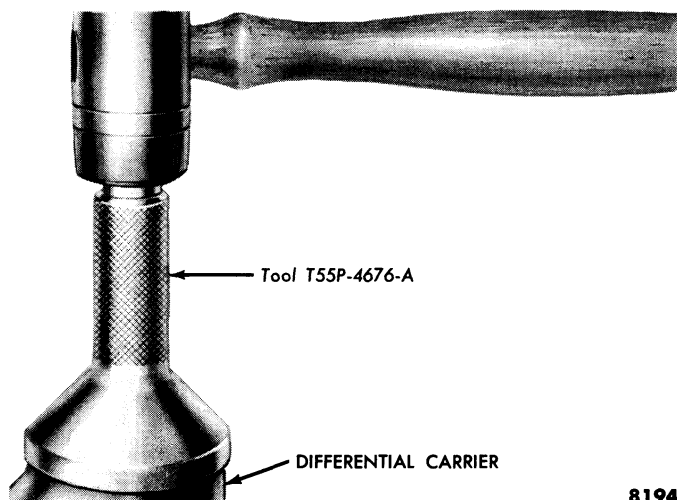

8194

Fig. 16—Oil Seal Installation

screws to 35-40 foot-pounds torque.

Drive the differential bearings on the case hubs with the replacer shown in fig. 17 until they are flush with the shoulder of the case.

(3) **DIFFERENTIAL INSTALLATION AND ADJUSTMENT.** The installation and adjustment procedures include checking the drive gear backlash, run-out, and gear tooth contact. These adjustments must be carefully done for dependable and quiet rear axle performance.

Place the differential side bearing cups on the bearings. Position the differential case assembly in the carrier so the adjusting nuts will engage approximately the

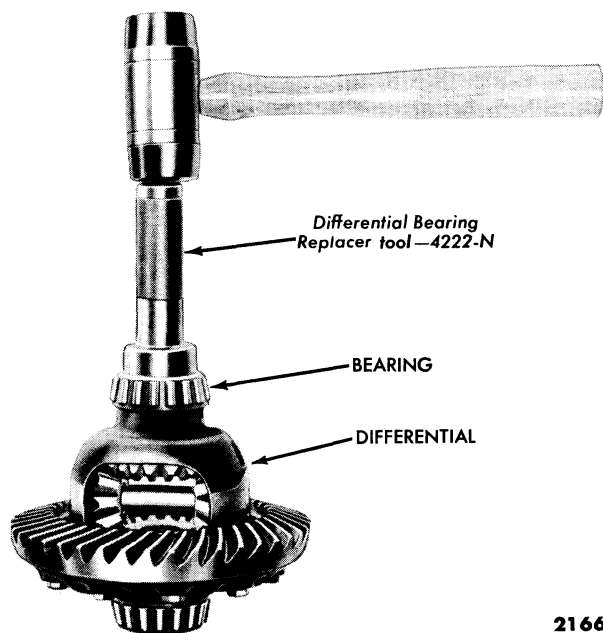

2166

Fig. 17—Differential Bearing Installation

same amount of the carrier threads at each end of the case.

Thread the adjusting nuts into the carrier and against the bearing cups. Be sure the nut threads index with the carrier threads. Carefully position the bearing caps on the adjusting nuts, aligning the marks made during disassembly. Be sure the bearing cap threads mesh with the adjusting nut threads. Install the bearing cap bolts, and tighten the bolts until snug. Turn the adjusting nuts while tightening the bolts, to be sure the threads are aligned. Back off the bolts about $\frac{1}{4}$ turn to allow the cups to move.

Be sure that the right-hand adjusting nut is loose. Tighten the left-hand adjusting nut (drive gear side of differential case) until the drive gear meshes with the drive pinion. Feel the backlash as the nut is being tightened. Continue tightening the nut until no backlash is evident. Tighten the left-hand nut two additional notches to properly seat and align the bearing cup. Rotate the differential case with load on bearings to seat rollers before final setting. Loosen the nut until it just contacts the bearing cup when the backlash is zero.

Tighten the right-hand adjusting nut until it contacts the bearing cup. Tighten the nut two additional notches to align the cup in the bore. Loosen the adjusting nut until it is clear of the cup, then carefully tighten the nut until it just contacts the bearing cup. Tighten the right-hand adjusting nut an additional 3 notches to properly pre-load the differential side bearings.

Tighten the bearing cap bolts to 75-80 foot-pounds torque. Install a dial indicator (fig. 18), and measure the backlash in several positions. If the backlash readings vary more than 0.003 inch, the runout of the gears is excessive.

The correct backlash is 0.003-0.008 inch. If the backlash is not within these limits, loosen the bearing cap bolts $\frac{1}{4}$ turn, and move the drive gear and case assembly as required.

To move the case assembly, loosen one adjusting nut one notch and tighten the opposite adjusting nut one notch. This method of adjustment must be followed to maintain the previously established pre-load. The final backlash setting should be within the specified limits and should produce the best possible gear tooth pattern.

(4) **GEAR TOOTH CONTACT.** Paint about 12 drive gear teeth with a suitable gear marking compound, such as a paste made with dry, red lead and oil. Too fluid a mixture will run and smear. Too dry a mixture cannot be squeezed out from between the teeth. Wrap

a cloth around the drive pinion flange and hold it tight to act as a brake, then turn the drive gear back and forth until a clear tooth contact pattern is obtained. Compare this pattern with the tooth patterns shown in fig. 1.

NOTE: *New gear sets have a heavy-load tooth contact pattern rolled on the gear teeth with a special machine. When a new set of gears is installed, duplicate this pattern as closely as possible.*

If the tooth pattern is incorrect, adjust the drive gear or pinion as required. Any necessary pattern correction should first be attempted by adjusting the backlash, since this requires less time than changing the pinion location. If changing the backlash within the specified limits, will not result in a satisfactory pattern, the location of the drive pinion will have to be changed.

NOTE: *A new spacer will be required for each build-up.*

(5) DIFFERENTIAL CARRIER INSTALLATION.

Place a new gasket on the axle housing studs, then position the carrier assembly on the housing. Install the axle identification tag on one of the upper carrier studs. Install the carrier to housing stud nuts, then tighten the nuts to 30-35 foot-pounds torque. Fill the axle housing to the level of the filler plug hole with M-4642-A lubricant (S.A.E. 90) for temperatures above -10° F, or M-4642B lubricant (S.A.E. 80) for temperatures below -10° F. After 5,000 miles of service on the parts, Multipurpose-Type Gear Lubricant can be used to bring lubricant up to proper level. The M-4642-A (or B) lubricant is essential for new or readjusted axles to prevent scoring of the gears until they are worn-in.

f. Rear Axle Overhaul.

Refer to fig. 8 for a disassembled view of the rear axle. The checking procedure for axle housing distortion is also covered here.

(1) **REMOVAL.** Remove the hub caps and loosen the wheel stud nuts. Raise the rear of the car, and install stands under the frame cross members. Remove the wheels, then disconnect the drive shaft at the rear axle universal joint flange. Disconnect the parking brake cable from the equalizer rod and the rear brake hose from the axle. Remove the spring clip (U-bolt) nuts and

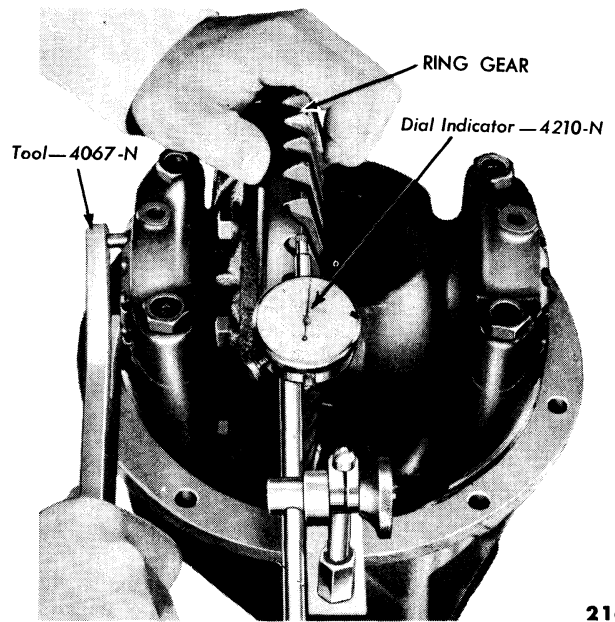

2167

Fig. 18—Checking and Adjusting Backlash

the spring-clips, then remove the rear axle assembly.

(a) **HOUSING INSPECTION.** Install the rear wheels, then install a telescopic-type toe gauge between the wheels. Hold the wheels stationary, rotate the axle housing through 360° , and note the scale readings on the gauge. If the readings do not vary while the housing is turning, the housing is straight. A variation in excess of $\frac{1}{8}$ inch indicates that the axle housing is bent and should be replaced.

(2) **DISASSEMBLY.** Remove the wheels. Remove the axle shafts and the differential carrier. Remove the differential from the carrier and disassemble. Remove the drive pinion.

(3) **ASSEMBLY.** Install the drive pinion with the correct depth adjustment. Assemble the differential and install it in the differential carrier. Install the differential carrier and the axle shafts.

(4) **INSTALLATION.** Position the axle assembly under the car. Secure the rear springs to the axle housing with the spring clips (U-bolts) and nuts. Tighten the spring clip nuts to 38-43 foot-pounds torque. Connect the rear brake hose to the axle, then connect the parking brake cable to the equalizer bar. Connect the drive shaft to the differential companion flange. Install the rear wheels, then lower the vehicle to the floor. Tighten the wheel stud nuts to 65-75 foot-pounds torque. Install the hub caps, then bleed the brakes.

4. INTEGRAL HOUSING HYPOID REAR AXLE

An integral housing hypoid rear axle (fig. 19) is used on the Station Wagons, Courier, Thunderbird, and Police Interceptor.

a. Construction.

A two-pinion differential assembly and a drive pinion assembly are installed in the one-piece axle housing. Steel thrust washers are installed behind the differential pinions and side gears. The drive pinion assembly is mounted in two opposed tapered roller bearings and can be adjusted by shims. A removable cover plate on the back of the housing permits access to the differential assembly and the drive pinion.

The outer ends of the axle shaft tubes on the housing are formed into flanges for attaching the brake carrier plates and the rear wheel bearing outer retainers. The rear spring seats are welded to the tubes. The axle shafts are of the semi-floating type and are supported at the inner ends by the differential side gears.

b. Axle Shaft Replacement.

The axle shafts may be replaced without removing the rear axle from the car.

(1) **REMOVAL.** Remove the wheel and tire assembly, then remove the nuts that secure the brake drum to the axle flange. Remove the brake drum. Working through the hole provided in the axle shaft flange, remove the nuts that secure the brake carrier plate to the axle housing. Pull the axle shaft assembly out of the

housing with the tool shown in fig. 5. Be careful not to dislodge the brake carrier plate or damage the oil seal in the housing. Install one nut to hold the brake carrier plate in place.

(2) **INSTALLATION.** If the original axle shaft is to be installed, check the rear wheel bearing and the oil seal for wear before installation. Grasp the bearing outer race and "rock" it on the axle shaft, checking for looseness at the oil seal. Visually inspect the bearing for lubricant leakage. If excessive looseness is evident or excessive lubricant appears on the bearing, replace the bearing.

If the oil seal in the axle housing is damaged or does not form a tight seal, replace the seal.

Remove the temporary nut holding the brake carrier plate to the housing. Lubricate the bearing bore in the axle housing. Clean the brake carrier plate surface, then install new gaskets on each side of the brake carrier plate.

Slide the axle shaft assembly in place in the axle housing, being careful not to damage the oil seal. Rotate the axle shaft until the shaft splines mate with the splines of the differential gears. Push the axle shaft assembly into the housing until the axle bearing is tight against the shoulder in the housing. Position the rear wheel bearing retainer plate on the rear axle housing. Install the retainer plate to housing bolts and lock nuts. Tighten the nuts to 30-35 foot-pounds torque. Position the brake drum on the axle flange, then install the nuts. Install the wheel and tire assembly. Check and adjust the brakes.

c. Drive Pinion Oil Seal Replacement.

The drive pinion oil seal may be replaced without removing the differential carrier from the car.

Disconnect the drive shaft at the rear universal joint. Mark the position of the universal joint flange, nut, and pinion shaft with a punch to aid in obtaining the same pre-load when assembling the unit. Remove the universal joint flange, nut, and washer. Remove the flange from the pinion shaft with the puller shown in fig. 6. Pull the pinion oil seal out of the housing with the tool shown in fig. 7.

Prior to installing the new pinion oil seal, check the lubricant drain-back passage in the housing, and the axle housing vent, for obstructions. Clean these parts if required. Inspect the carrier bore chamber and the

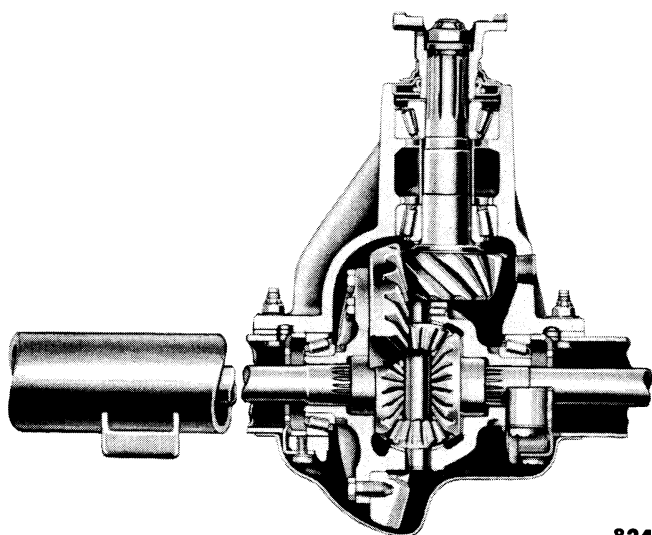

8248

Fig. 19—Integral Housing Hypoid Rear Axle

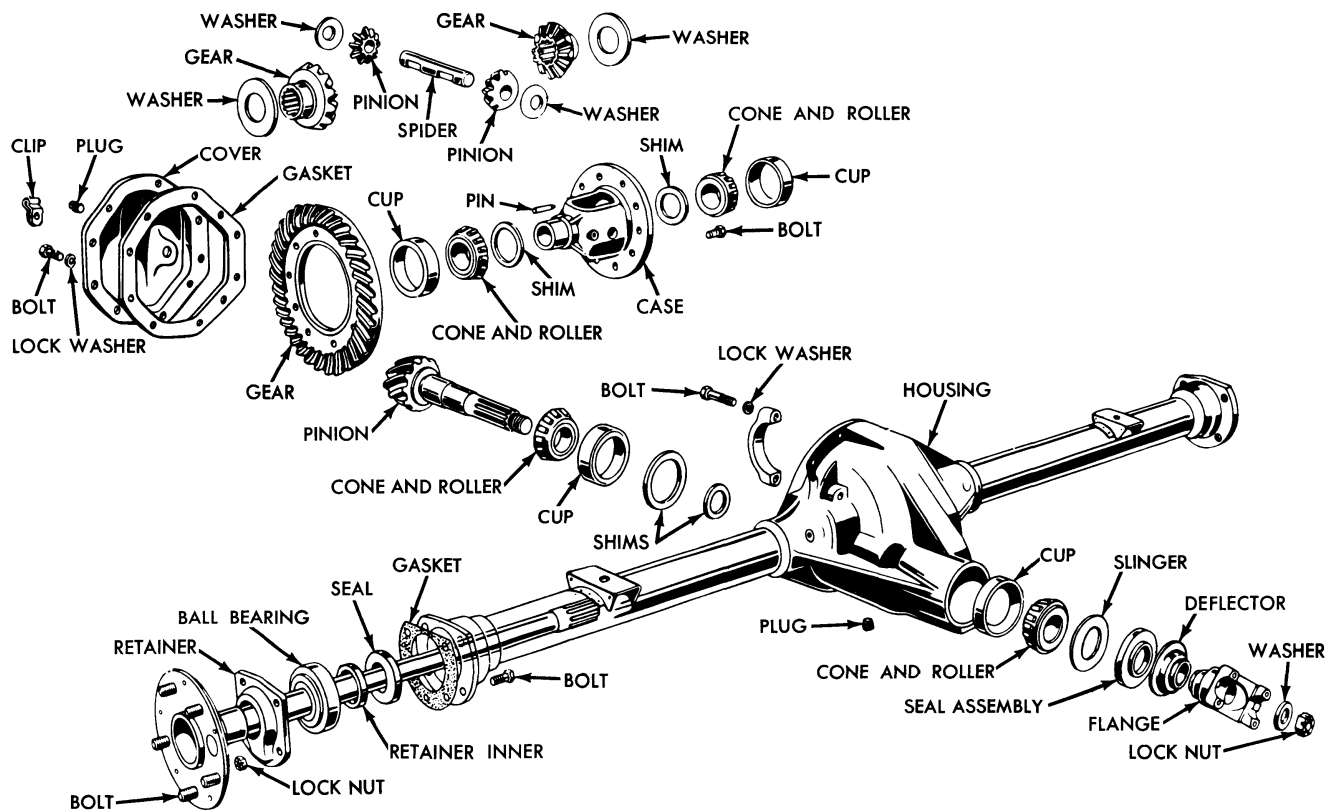

8249

Fig. 20—Integral Housing Hypoid Rear Axle

universal joint flange for nicks. Remove all nicks with a file or stone. Coat the seal bore in the carrier with Permatex, Tite-seal, or the equivalent.

NOTE: Soak new seals in light engine oil for one-half hour before installation.

Install the oil seal with tool-4676-P. Place the universal joint flange on the pinion shaft with the punch marks in line. Install the flange (fig. 25). Install the washer and nut on the pinion shaft, then tighten the nut until it is tight on the pinion shaft with the punch marks on the flange, nut and pinion shaft aligned. Connect the drive shaft on the rear universal joint.

d. Differential Repair.

These repair procedures also include the operations for servicing the drive pinion assembly. Refer to fig. 20 during disassembly of the axle.

(1) **REMOVAL.** Drain the lubricant from the rear axle carrier and remove the rear cover. Make sure the differential side bearing caps and the axle housing are clearly marked, then remove the differential side bearing caps.

Install the spreader tool as shown in fig. 21. Make sure the tool hold-down clamp screws are tight. Spread the housing until the differential assembly can be forced out with a small pry-bar or a heavy screw driver.

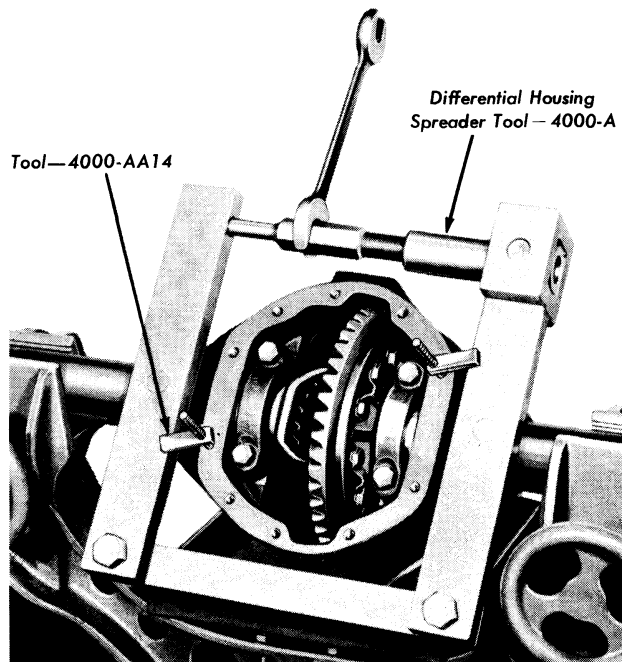

Fig. 21—Differential Assembly Removal

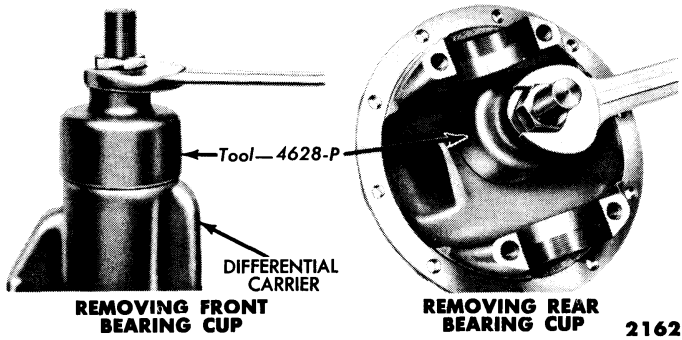

Fig. 22—Drive Pinion Bearing Cup Removal

CAUTION: Do not spread the housing more than 0.020 inch to remove the differential assembly. Remove the spreader immediately after lifting out the differential assembly to prevent springing the housing.

(2) **DIFFERENTIAL DISASSEMBLY.** Remove the cups from the differential side bearings. Remove the differential side bearings using the tool shown in fig. 9.

NOTE: If the original differential side bearings and cups are to be assembled in the axle, keep each bearing and its cup together.

Remove the cap screws and the drive gear.

Drive out the lock pin securing the differential pinion shaft in the case. Remove the differential pinion shaft, differential pinions, and thrust washers. Remove the differential side gears and thrust washers.

(3) **DRIVE PINION REMOVAL AND DISASSEMBLY.** Remove the nut and washer from the pinion shaft while holding the universal joint flange.

Remove the flange with the tool shown in fig. 6.

Press the pinion out the rear of the axle housing.

Remove the pinion shaft oil seal, gasket, oil slinger, pinion front bearing, and shim pack. Record the thickness of the shims.

Remove the pinion front bearing cup, pinion rear bearing cup, and shim pack from the housing, with the tools shown in fig. 22. Make a note of the total thickness of the shims.

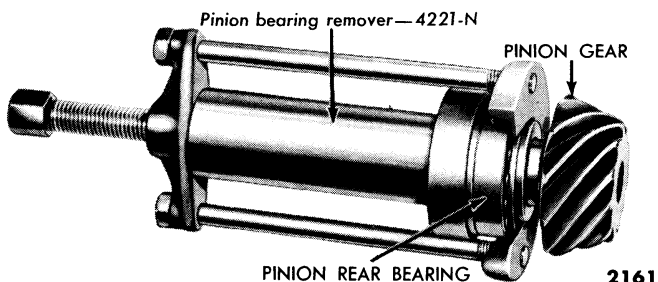

Fig. 23—Pinion Rear Bearing Removal

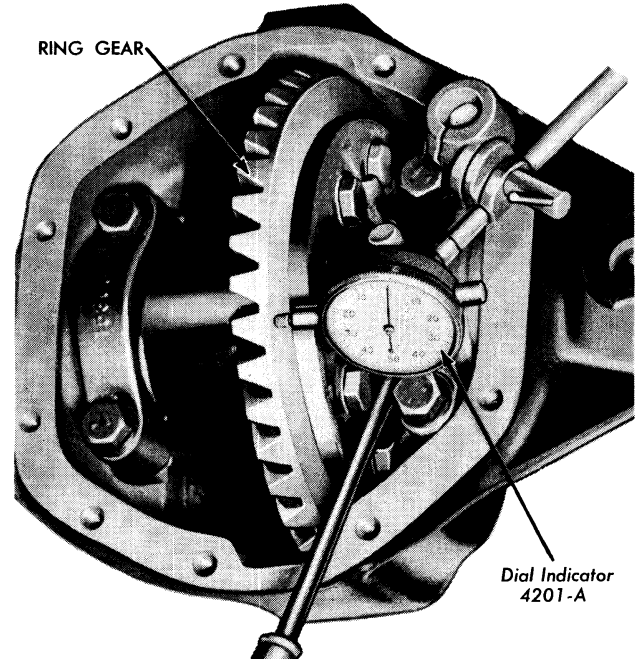

Fig. 24—Differential Bearing Adjustment

Press the rear bearing off the pinion shaft (fig. 23) and note the marking on the face of the pinion.

(4) **DIFFERENTIAL ASSEMBLY.** Coat all differential parts with lubricant. Install the differential side gears and thrust washers, the differential pinions and thrust washers, and the differential pinion shaft in the case. Secure the pinion shaft in the case, with the lock pin. Position the drive gear on the case and secure it in place with the cap screws.

(5) **DIFFERENTIAL BEARING ADJUSTMENT.** Press new bearings on the differential assembly without shims, and install the bearing cups. Install the differential in the housing, then install the bearing caps. Tighten the cap screws just enough to keep the bearing caps in place.

Install a dial indicator (fig. 24). Rotate the drive gear and check the runout. If the runout exceeds 0.006 inch total indicator reading, remove the assembly from the housing, and remove the drive gear from the case. Install the differential case in the housing, and check the runout of the case flange and gear pilot.

If runout exists at either place, the drive gear is probably true, and the runout is due to a worn case or defective differential bearings. Replace the bearings. If the runout still exists, replace the differential case. After the runout condition has been corrected, tighten the gear to case cap screws to 40-50 foot-pounds torque.

Install the dial indicator on the housing as shown in fig. 24. Pry the differential assembly away from the dial indicator, then set the indicator to zero. Pry the differ-

ential assembly toward the indicator, and note the indicator reading. This reading indicates the amount of shims needed behind the differential side bearings. Remove the bearing caps and lift the differential assembly from the housing.

NOTE: *Do not install shims behind the bearings at this time.*

(6) DRIVE PINION INSTALLATION AND DEPTH ADJUSTMENT. Both gears in each drive pinion and ring gear set are matched and lapped as a pair at the factory, then machine set to obtain the correct gear tooth contact pattern (fig. 1) and backlash. With this pattern, the correct drive pinion depth setting, which is the positive (+), negative (−), or zero (0) variation in thousandths of an inch from a standard or “nominal” depth setting, is marked on the rear face of each pinion. When replacing a drive pinion and drive gear set, the depth setting markings on both old and new drive pinions are used to determine the new shim pack thickness under the drive pinion rear bearing cup.

When installing a new drive pinion that has the same marking as the old pinion, do not change the shim pack thickness.

Should a pinion marked plus (+) 5 be used to replace a pinion marked zero, then 0.005 inch in shims should be removed from the pinion rear bearing cup pack. Removing the shims will move the pinion farther from the drive gear, and increase the standard dimension between the pinion rear face and the center of the drive gear by 0.005 inch.

A minus (−) marked pinion replacing a zero marked pinion calls for the addition of shims to the rear bearing cup pack, to decrease the standard dimension by the amount of the marking.

In case a pinion marked plus (+) 5 is used to replace one marked minus (−) 3, 0.008 inch in shims must be removed from the rear bearing cup pack. Of the 0.008 inch shim change, 0.003 inch is removed to bring the setting back to standard, and 0.005 inch is removed to locate the new plus (+) 5 marked pinion 0.005 inch farther from the drive gear than standard. The opposite applies if a minus (−) marked pinion replaces a plus (+) marked pinion.

Since the pinion depth gauges (fig. 27) rest on the pinion gear rear face, remove any nicks or burrs with a hand stone. Do not grind.

Add or subtract from the original shim pack as required, then place it in the housing. Install the front and rear bearing cups in the housing (fig. 26). Press the rear bearing on the pinion shaft and place the assembly

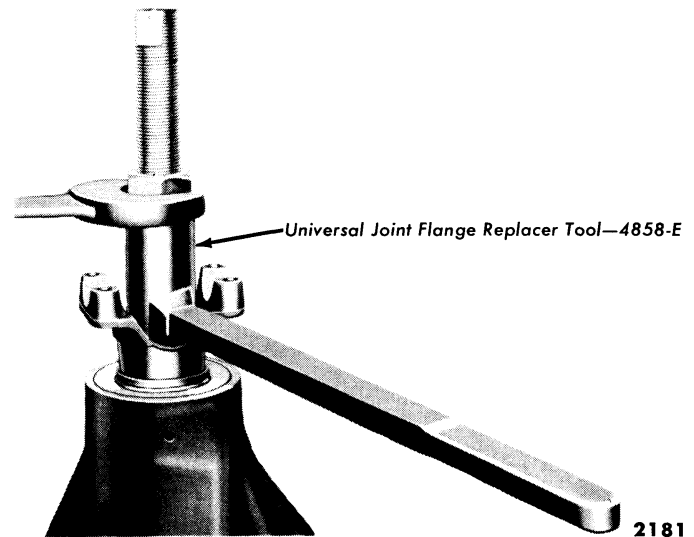

Fig. 25—Universal Joint Flange Installation

in the housing. Place the front bearing without shims on the pinion shaft, then install the universal joint flange with the tool shown in fig. 25. Press the bearing and flange on the shaft carefully, to adjust the pre-load on the pinion bearings to 10-30 inch-pounds.

Check the pinion setting with either tool shown in fig. 27.

If the dial indicator tool is used, install the smaller discs in the bearing pockets and seat by installing the bearing caps and tightening securely. Attach the dial indicator to its holder and place it on the lower step of the gauge block. Place the gauge block squarely on the drive pinion gear and squarely against the gauge shaft.

With the indicator button resting on the gauge block set the dial face to read zero. Swing the indicator (fig. 27) to the highest point on the gauge shaft and note the reading at the highest point.

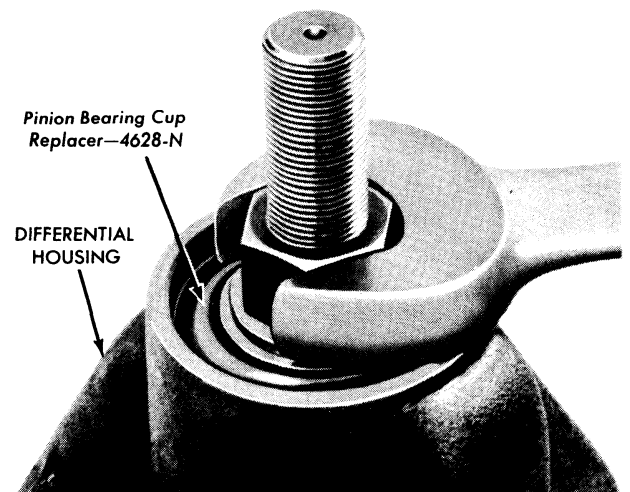

Fig. 26—Drive Pinion Bearing Cup Installation

NOTE: *The highest point on the gauge shaft is the point of highest indicator reading while the indicator hand is moving clockwise.*

The indicator reading at the highest point on the gauge shaft must correspond with the pinion gear marking. Thus, a pinion gear marked zero installed at the proper depth will give an indicator reading of zero at the highest point on the gauge shaft.

A plus (+) reading (clockwise from 0 on the indicator face) at the highest point on the gauge shaft with a zero marked pinion means that the pinion is too deep in the housing in the amount of the plus (+) reading. To correct add shims in thousandths of an inch that corresponds to the plus (+) reading. For example, an indicator reading of plus (+) 10 with a zero marked pinion means that 0.010 inch in shims must be added to the rear bearing cup pack.

Likewise a minus (−) reading (counterclockwise from zero) at the highest point on the gauge shaft with a zero marked pinion, means that the pinion is too close to the drive gear in the amount of the minus (−) reading. To correct remove shims in thousandths of an inch equal to the minus reading.

A minus (−) 3 marked pinion is installed at the proper depth when the indicator reads minus (−) 3 at highest point on the gauge shaft. Likewise a plus (+) 3 marked pinion is installed at the proper depth when the indicator reads plus (+) 3 at the highest point on the gauge shaft.

Pinion settings within plus (+) 3 and minus (−) 1 of the desired setting are within limits. For example, a pinion marked plus (+) 3 is set within limits if the indicator reading at the highest point on the gauge shaft

is between plus (+) 2 and (+) 6.

If the micrometer tool (fig. 27) is used to measure pinion depth, micrometer readings must be interpreted according to pinion markings. Table 3 gives the micrometer readings that should be obtained for each pinion marking. If the micrometer reading is 0.003 inch higher to 0.001 inch lower than desired, the pinion setting is within limits. For example, with a pinion marked minus (−) 3 the micrometer reading may be between 1.621 and 1.625.

Remove shims from the rear bearing cup pack to increase micrometer readings and add shims to decrease readings.

Whenever the pinion rear bearing cup shim pack is changed, install the drive pinion and recheck the pinion depth.

After the pinion depth has been adjusted and checked, remove the universal joint flange and front bearing. Add or subtract from the original front pinion bearing shim pack the same amount in thousandths of an inch, that was added to or subtracted from the rear bearing cup shim pack. Install the front bearing shim pack, front bearing, universal joint flange, washer and nut. Tighten the flange nut to 200-220 foot-pounds torque.

Check the drive pinion bearing pre-load with a strong cord and pull scale. The pre-load should be from 10-30 inch pounds. Add or remove shims from the front bearing shim pack, until the proper pre-load is obtained. Remove the universal joint flange, and then install the oil slinger, oil seal gasket and oil seal.

NOTE: *Soak the new oil seal in light engine oil for 30 minutes, before installation.*

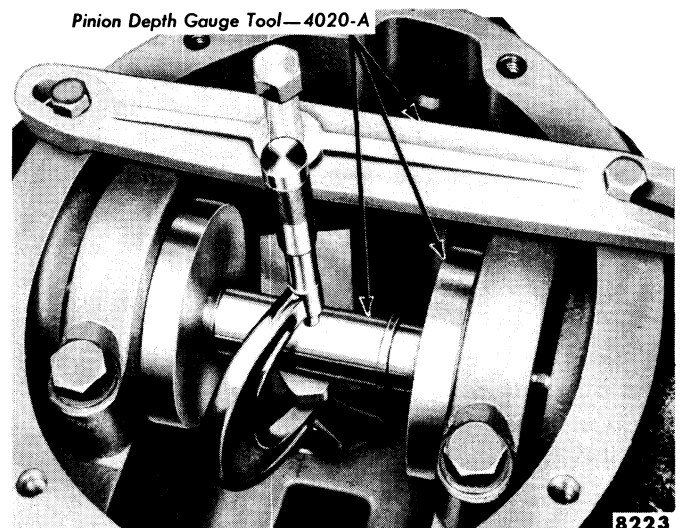
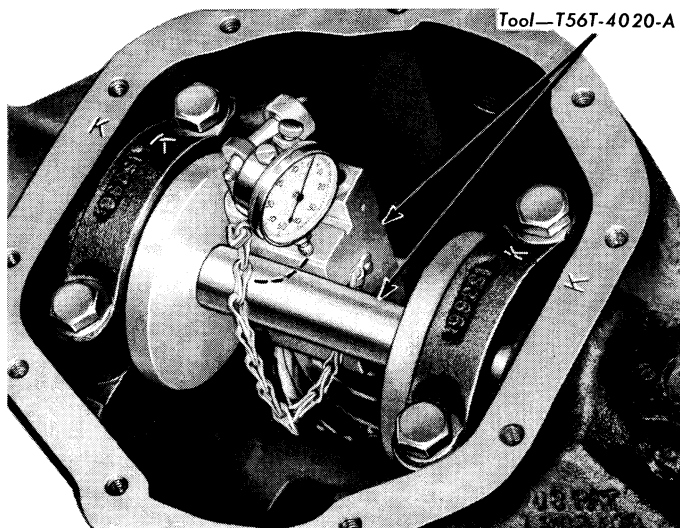

Fig. 27—Pinion Depth Measurement

Install the universal joint flange, washer and nut. Tighten the flange nut to 200-220 foot-pounds torque.

(7) BACKLASH AND PRE-LOAD ADJUSTMENT.

Install the drive gear and differential assembly in the housing, and tighten the bearing caps lightly. Install the dial indicator with the button against the back face of the drive gear. Move the differential and drive gear assembly until tight against the pinion gear, then set the indicator face to zero. Move the differential away from the pinion as far as it will go, and note the indicator reading. This measurement indicates the amount of shims to be placed behind the differential bearing on the drive gear side of the differential assembly. The balance of shims (the difference between the total amount of shims to be installed behind the differential side bearings, and the amount to be installed behind the differential bearings on the drive gear side), plus the 0.015-0.020 inch shims to provide the correct bearing pre-load and backlash, will be installed on the differential end of the assembly.

EXAMPLE:

Indicator reading recorded in	
paragraph (6)	0.070 inch
Recorded reading in paragraph (7)	0.038 inch
Amount of shims to be installed behind	
bearing at drive gear end of case	0.038 inch
Amount of shims to be installed behind	
bearing at differential end of case	
(0.070-0.038 + 0.017 inch for pre-	
load and backlash)	0.049 inch

Remove the bearing caps and lift the differential assembly from the housing. Remove the differential side bearings, then install the proper amount of shims on each side of the differential case. Press the side bearings on the case until they are firmly seated against the shims.

(8) DIFFERENTIAL INSTALLATION.

Install the axle housing spreader (fig. 21), spread the axle housing not more than 0.020 inch, then install the differential assembly. Rotate and tap the drive gear alternately with a soft hammer to assure the proper seating of the bearings in the cross bores. Install the bearing caps, then remove the spreader. Coat the cap screw threads with

sealer, then install and tighten the cap screws to 70-90 foot-pounds torque.

Install a dial indicator, then check the backlash at four equally spaced points around the drive gear. The backlash must be held to 0.004-0.009 inch and cannot vary more than 0.002 inch between the positions checked. If the backlash is not within specifications, change the shim packs behind both the differential side bearings. Check the gear tooth contact (fig. 1) to be sure it is correct.

Place a new gasket on the rear face of the axle housing, then install the rear cover and ratio identification tag. Tighten the cap screws to 15-25 foot-pounds torque. Install the axle shafts.

Fill the axle housing to the level of the filler plug hole with rear axle lubricant. If a new drive gear and pinion set has been installed, use break-in lubricant (M-4642-A). If the original drive gear and pinion set is installed use Multipurpose-Type Gear Lubricant. Bleed the brake system and adjust the brakes.

e. Rear Axle Overhaul.

Refer the fig. 20 for a disassembled view of the rear axle. The checking procedures for axle housing distortion is also covered here.

(1) REMOVAL. Remove the hub caps, then loosen the wheel stud nuts. Raise the rear of the car, then disconnect the hydraulic brake hose from the hydraulic brake line at the rear axle. Disconnect the parking brake cable from the equalizer rod, then remove the cable assembly from the frame brackets. Remove the wheels, then disconnect the drive shaft at the rear axle universal joint flange. Remove the nuts from the rear spring clips (U-bolts), then remove the spring clips. Remove the axle assembly from the car.

(a) HOUSING INSPECTION. Install the wheels, then install a telescopic-type toe gauge between the wheels. Hold the wheels stationary, rotate the axle housing through 360° and note the readings on the gauge. If the readings do not vary while the housing is turning the housing is straight. A variation in excess of 1/8 inch indicates that the axle housing is bent and should be replaced.

Table 3—Pinion Depth Measurement Chart—All Ratios

Pinion Marking	-5	-4	-3	-2	-1	0	+1	+2	+3	+4	+5	+6	+7	+8	+9	+10
Micrometer Reading	1.620	1.621	1.622	1.623	1.624	1.625	1.626	1.627	1.628	1.629	1.630	1.631	1.632	1.633	1.634	1.635

(2) **DISASSEMBLY.** Remove the wheels. Remove the axle shafts. Remove and disassemble the differential. Remove and disassemble the drive pinion.

(3) **ASSEMBLY.** Install the drive pinion with the correct depth adjustment. Assemble and adjust the differential, then install the differential in the axle housing. Install the axle shafts.

(4) **INSTALLATION.** Position the rear axle assembly under the car. Install the spring clips (U-bolts),

washers, and nuts. Tighten the nuts to 38-43 foot-pounds torque. Connect the drive shaft to the rear axle universal joint flange. Connect the parking brake cable to the equalizer rod, then install the brake cable assembly in the frame brackets. Connect the hydraulic brake hose to the rear axle hydraulic brake line. Install the rear wheels, then lower the car to the floor. Tighten the wheel stud nuts to 65-75 foot-pounds torque. Install the hub caps, then bleed and adjust the brakes.

5. DRIVE LINES

A Hotchkiss-type drive line transmits power from the transmission to the rear axle. The drive line consists of a tubular shaft and two universal joints. Yokes, which form part of the universal joints are pressed into and welded to the ends of the shaft. The internally-splined knuckle on the forward universal joint forms a slip joint with the transmission output shaft. The rear universal joint flange is keyed and bolted to the rear axle drive pinion flange.

All drive lines are balanced. Therefore, if the car is to be undercoated, cover the drive lines to prevent undercoating material getting on the shaft or universal joints.

a. Universal Joint Replacement.

The universal joints are of the needle bearing type. The universal joint bearings are retained on the universal joint spiders by snap rings (fig. 28).

To replace a universal joint, remove the snap rings

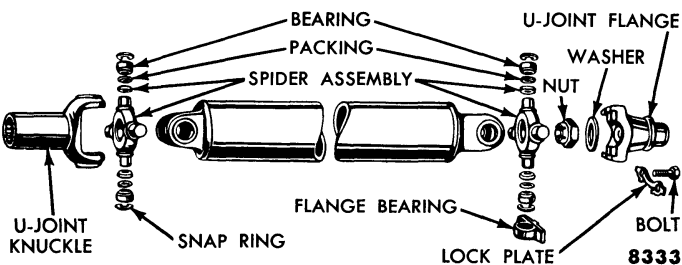

Fig. 28—Drive Line—Disassembled

(fig. 28) from under the yoke and around the needle bearing races. With a drift approximately the same size as the needle bearing race, press one bearing race through the yoke. With a pair of pliers, remove the opposite bearing which is partially forced out of the yoke. Remove the spider from the yoke, then repeat the same procedure for the other pair of bearings.

NOTE: *When removing a needle bearing assembly from the yoke, use care not to damage bearings.*

To install, pack the needle bearings and the recesses in the end of the spider with universal joint grease. Place the spider in the yoke, and press in the bearings. Secure the bearings in the yoke with the snap rings.

b. Drive Shaft Replacement.

Disconnect the rear universal joint from the universal joint flange. Pull the drive shaft toward the rear of the car until the universal joint knuckle clears the transmission extension housing and the seal.

If the rubber bellows type seal installed on the end of the transmission extension housing is damaged in any manner, install a new seal.

Dip the knuckle in transmission lubricant, then insert the knuckle into the seal and the transmission extension housing as far as it will go. Install the lock plates and cap screws which attach the universal joint to the flange.

Part TWO

CHASSIS

Chapter

III

Running Gear

Section	Page
1 Trouble Shooting	159
2 Wheel Alignment	161
3 Frames	163
4 Front Suspension	164
5 Rear Suspension	168
6 Shock Absorbers	169
7 Steering Gear	170
8 Steering Linkage	175
9 Wheels and Tires	178
10 Hubs and Bearings	181

The running gear consists of all the units which support the weight of the car and which are used to steer the car. This chapter contains service information on

all of the running gear units, except the rear axle, and includes procedures for trouble shooting, checking and adjusting, repairing, and replacing the various units.

I. TROUBLE SHOOTING

Table 1 lists the running gear trouble symptoms and their causes in the most probable order of occurrence, as indicated by the numbers that appear beneath each trouble symptom.

a. Abnormal Tire Wear.

All abnormal tire wear can be generally classified in two ways: around-the-tire (lengthwise) wear and across-the-tire (crosswise) wear. The type of tire wear often indicates the cause of the trouble.

Around-the-tire (lengthwise) wear can be caused by the tendency of the wheel to resist rotation or to spin when the car is moving. Excessive camber can cause more rapid wear on one side of the tire tread than on the other.

Across-the-tire (crosswise) wear can be caused by incorrect toe-in or toe-out and by excessive distortion due to high camber.

b. Wander.

Wander is a term used to designate a tendency of the car to turn slightly to one side or the other when the driver is trying to drive straight ahead.

EXAMPLE: *On a smooth and straight road, the car veers toward the right side of the road without the driver having turned the steering wheel. The driver then turns the steering wheel to straighten the course but in so doing he oversteers. The car now veers to the left with the result that the driver is continually turning the steering wheel to keep the car traveling straight ahead.*

c. Pull to One Side.

Pull to one side is a tendency for the car to turn toward one side when the driver is trying to drive straight ahead. As a result, the driver keeps a constant pull on the steering wheel to drive straight.

d. Wheel Tramp.

Wheel tramp is a violent vertical motion of the wheels that develops at high speed. Wheel tramp is disagreeable, dangerous, and places unnecessary strain on the entire car.

e. Cupped Tires.

If the rolling radius of the tire is less than normal

Table 1—Causes of Trouble and Probable Order of Occurrence

Causes	Trouble Symptoms													
	A	B	C	D	E	F	G	H	I	J	K	L	M	N
	Abnormal Tire wear	Wander	Pull to one side	Wheel tramp	Cupped tires	Road sway	Jerky steering	Shimmy	Loose steering	Hard steering	Hard turning when stationary	Erratic steering when braking	Tire squeal on turns	Looseness and noise
1 Tire pressure	1	2	1	9	1	1		1		1	1		1	
2 Tight spindle bearings		1				2				2				
3 Loose spindle bearings	6				3		8	2	1					4
4 Loose connecting rod ends and connections	14	10		5	2			3	2					3
5 Broken spring tie bolts	13	11	6	7	4	8		5	4			5		
6 Tire overload	5	16			6	5				6	7			
7 Broken spring	11	12	5	8	5	9		6	5			4		
8 Loose steering gear mountings		13		6		7		4	3					2
9 Wheel balance	8			1	7		3							
10 Steering gear bind						6				3	2			
11 Caster low		4		4			9							
12 Bent spindle		14	14				7			7			4	
13 Camber plus side inclination unequal			9		11								3	
14 Toe-in too great	2	9											2	
15 Radial run-out				2	8		4							
16 Lateral run-out				3	9		5							
17 Unequal brake adjustment	10		3									1		
18 Bent spindle arm		15	13										5	
19 Camber low		3								5				
20 Caster high										4	3			
21 Caster uneven		5	8											
22 Camber plus side inclination high		6									4			
23 Camber plus side inclination low		7									5			
24 Steering gear off center			10				1							1
25 Spring sag	12					10								
26 Loose or worn shock absorber				10		4								5
27 Cupped tires				11			2							
28 Over-size tires								7			6			
29 Unequal tire diameter	7		2											
30 Bent rear axle housing	15		11											
31 Bent frame	19		12											
32 Dragging brakes	3		15											
33 Camber high	4													
34 Camber uneven			7											
35 Tight wheel bearings			4											
36 Loose wheel bearings												3		6
37 Toe-in too little		8												
38 Loose or worn stabilizer						3								7
39 Not tracking	9													
40 Rear axle toe-in	16													
41 Rear axle toe-out	17													
42 Rear axle camber	18													
43 Out-of-round brake drum					10							2		
44 Bent steering arm							6							

due to overloading or under-inflation or if the tire grooves are inadequate, cupping will result. Camber causes the tire to have several different rolling radii and excessive camber may also result in cupping. Continued operation of a car that has front wheel tramp or shimmy will result in cupped tires.

f. Road Sway or Body Roll.

Road sway or body roll is a tendency of the car to rock while driving in a cross wind. Body roll has a tendency to cause the driver to lean and at the same time turn the steering wheel. As a result, the car will weave or sway from side to side.

g. Jerky Steering.

The most common cause of jerky steering or road shock is failure to have the steering gear in midposition. A bruised tire causing a blister could cause jerky steering.

h. Shimmy.

Shimmy is a tendency of the front wheels to oscillate about the spindle ball joints. This movement of the front wheels may or may not be transmitted through the steering wheel. Low-speed shimmy often starts while crossing railroad tracks or driving over rough surfaces.

i. Loose Steering.

Loose steering may be caused by looseness in the wheel and spindle assembly, steering connections or steering gear, and at the points where the steering gear housing is attached to the frame.

j. Hard Steering.

Hard steering is usually caused by tightness of the steering gear mesh adjustment or spindle ball joint bearings. Incorrect front wheel alignment or underinflated tires could also cause hard steering.

k. Hard Turning When Stationary.

Hard turning when stationary is caused by underinflated tires, tight steering gear or spindle ball joint bearings. High or low camber plus king pin side inclination could, likewise, cause hard steering when stationary.

l. Erratic Steering When Braking.

Erratic steering when the brakes are applied is usually caused by oil soaked brake lining, out-of-round drums, improperly adjusted brakes, or under-inflation of the tires. These conditions often cause the car to turn or veer to the side when the brakes are applied.

m. Tire Squeal on Turns.

Some slippage results between the tire and the road surface when a car is turned at high speed, and an occasional squeal may be heard from a car with correct wheel alignment. The tendency to squeal increases with under-inflation. Incorrect spindle arm angle (toe-out on turns) could increase the slippage (spindle arm angle is not critical).

n. Looseness and Noise.

A number of factors must be considered when attempting to eliminate looseness or noise in the front suspension. All of the factors should be considered to avoid overlooking a possible cause of the complaint.

2. WHEEL ALIGNMENT

Wheel alignment involves all the factors that affect the running and steering of the front wheels. All of these factors must be considered when checking and adjusting wheel alignment. For this reason, definite checking and correction procedures should be followed.

a. Checking Procedures.

Different makes of stationary or portable equipment may be used for checking wheel alignment, provided the results obtained are accurate. It is essential that wheel alignment checking be performed by someone familiar with alignment work and with the equipment being used.

(1) **LEVEL FLOOR.** As all the factors of wheel

alignment are established from either a true horizontal or a true vertical plane, the car must be reasonably level when wheel alignment is being checked. The large runway type of wheel alignment equipment automatically levels the car. If portable equipment is used, a level area large enough to accommodate the car should be marked off.

(2) **CHECK TIRE PRESSURE.** Check the air pressure in all the tires. Make sure the pressure agrees with the specified pressure for the tires and car model being checked. Both front tires must be at the same pressure.

(3) **STRAIGHT-AHEAD POSITION.** Drive the car in a straight line far enough to establish the straight-ahead position of the steering wheel. Stop the car and

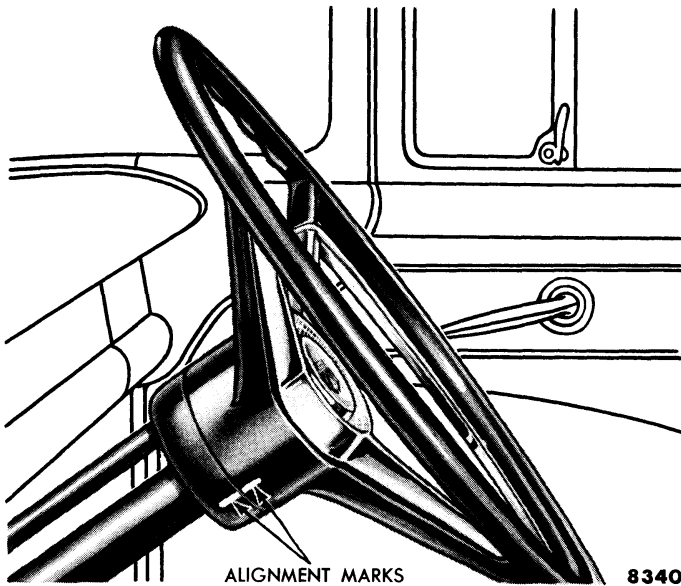

Fig. 1—Straight-Ahead Position Alignment Marks

place corresponding chalk marks on the steering wheel hub and on the steering column (fig. 1). To place the front wheels in the straight-ahead position at any time during the checking procedures, align the mark on the steering column.

(4) **CHECK WHEEL BEARINGS.** Raise the front wheels off the floor. Grasp each front tire at the front and rear, then push the wheel inward and outward. If any free play is noticed, adjust the wheel bearings. Replace the bearings if they are worn or damaged.

(5) **CHECK BALL JOINTS AND MOUNTINGS.** With the front wheels off the floor, grasp the tire at the top and bottom, and shake the wheel. Watch the movement of the brake carrier plate. If looseness is noticed, check the ball joint mountings for tightness. If the mountings are properly tightened, replace the worn ball joints.

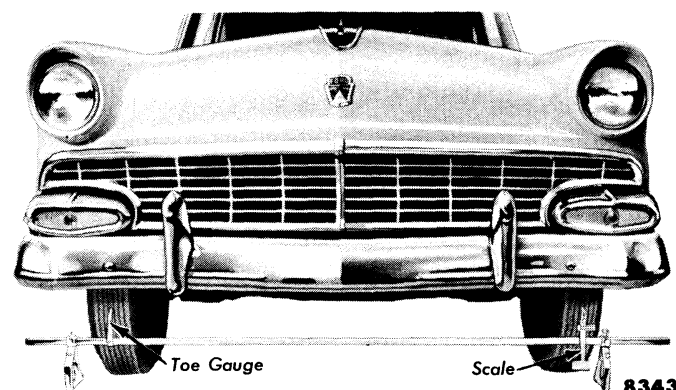

Fig. 2—Checking Front Wheel Toe

(6) **CHECK STEERING LINKAGE.** With the front wheels off the floor, grasp the front of both front wheels, push them away from each other, then pull them toward each other. Watch the spindle connecting rod (tie rod) ends for looseness. Replace worn parts.

(7) **CHECK MOUNTING BOLTS.** Check the steering gear mounting bolts and tighten them to specifications wherever required. Check the idler arm bracket mounting bolts and tighten if necessary.

(8) **CHECK WHEEL BALANCE.** Spin each front wheel with a wheel spinner, and check the wheel balance. An out-of-balance wheel will cause the front of the car to shake. Balance the wheels if required.

(9) **CHECK CASTER.** Position the car in the wheel alignment stall with the front wheels in the center of the white level spots on the floor. Install a suitable gauge on the front wheels and check the caster angle. The correct caster angle should be $\frac{1}{2}^{\circ}$ to $1\frac{1}{2}^{\circ}$. The maximum difference between the wheels should not exceed $\frac{1}{2}^{\circ}$.

(10) **CHECK CAMBER.** Adjust the gauge on the wheels, and check the camber angle. The correct camber angle should be $\frac{1}{4}^{\circ}$ to $1\frac{1}{4}^{\circ}$. The maximum difference between wheels should be $\frac{1}{4}^{\circ}$.

(11) **CHECK TOE.** Push the car backwards approximately six feet, then pull the car forward about three feet. Place a suitable toe gauge at the front wheels. The scale pointer will register toe. The toe-in should be $\frac{1}{16}$ to $\frac{1}{8}$ inch. Figure 2 shows one type of toe gauge in use.

NOTE: *When checking toe on cars equipped with power steering, the engine should be running so that the power steering control valve will be properly centered.*

(12) **CHECK KING PIN INCLINATION.** Check for damaged suspension parts. The angle of king pin inclination is a "built in" factor and will be correct unless the related parts are bent.

b. Correction of Factors.

Caster, camber, and toe can be adjusted if not within specifications. Correction of alignment factors by bending any of the suspension members is definitely not recommended.

(1) **CASTER ADJUSTMENTS.** The caster adjustments are made between the upper suspension arm inner shaft and the frame. Loosen the two bolts that secure the inner shaft to the frame. Insert or remove shims between the inner shaft and the frame to obtain the desired caster angle.

On all cars except the Thunderbird, the addition of $\frac{1}{16}$ inch in shims at the front bolt, or the removal of

$\frac{1}{16}$ inch in shims at the rear bolt, will change the caster angle $\frac{1}{2}^\circ$ in a positive direction. $\frac{1}{16}$ inch in shims added at the rear bolt, or $\frac{1}{16}$ inch in shims removed from the front bolt, will change the caster angle $\frac{1}{2}^\circ$ in a negative direction.

On the Thunderbird, the addition of $\frac{1}{16}$ inch in shims at the front bolt, or the removal of $\frac{1}{16}$ inch in shims at the rear bolt, will change the caster angle $\frac{1}{2}^\circ$ in a negative direction. $\frac{1}{16}$ inch in shims added at the rear bolt, or $\frac{1}{16}$ inch in shims removed from the front bolt, will change the caster angle $\frac{1}{2}^\circ$ in a positive direction. Shims are available in thicknesses of $\frac{1}{32}$ inch and $\frac{1}{8}$ inch. When the desired caster angle has been obtained, tighten the bolts to 65-90 foot-pounds torque.

NOTE: *The maximum difference between the shim stack thicknesses at the two bolts should not exceed $\frac{1}{8}$ inch.*

(2) **CAMBER ADJUSTMENTS.** The camber adjustments are also made between the inner shaft and the frame. Loosen the two inner shaft to frame bolts, then insert or remove the necessary shim thickness, at both bolts, to obtain the correct camber angle.

On all cars except the Thunderbird, the addition of each $\frac{1}{16}$ inch thickness at both bolts will change the camber angle $\frac{1}{4}^\circ$ in a positive direction. Each $\frac{1}{16}$ inch of shim thickness removed at both bolts will change the camber angle $\frac{1}{4}^\circ$ in a negative direction.

On the Thunderbird, the addition of each $\frac{1}{16}$ inch of shim thickness at both bolts will change the camber angle $\frac{1}{4}^\circ$ in a negative direction. Each $\frac{1}{16}$ inch of shim thickness removed at both bolts will change the camber angle $\frac{1}{4}^\circ$ in a positive direction.

The total shim stack thickness should not exceed $\frac{9}{16}$ inch.

NOTE: *Both caster and camber adjustments can be made at the same time after the wheel alignment checks have been completed.*

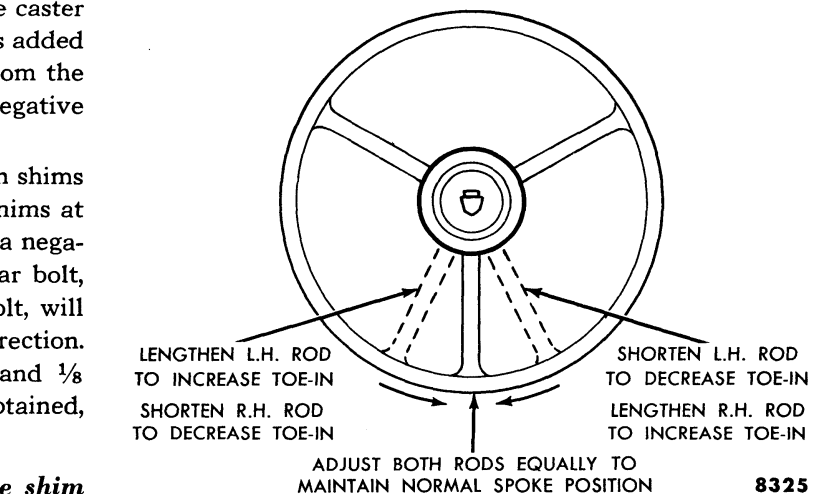

Fig. 3—Toe Adjustment and Steering Wheel Spoke Alignment

(3) **TOE ADJUSTMENT.** If the toe is incorrect, note the position of the steering wheel spokes when the front wheels are in the straight ahead position. If the spokes are in the normal position, lengthen or shorten both spindle connecting rods equally to obtain correct toe.

NOTE: *To lengthen or shorten both connecting rods equally, the right and left connecting rod sleeves must be turned an equal number of turns, but each in an opposite direction.*

If the spokes are rotated clockwise from the normal position, make the adjustments as shown at the top of fig. 3. If the spokes are rotated counterclockwise, adjust toe as shown at the bottom of fig. 3. By making the toe adjustments in this manner, the steering wheel spokes are moved toward the normal position at the same time. If the steering wheel spokes are still not in the normal position after the toe is adjusted, adjust the spoke position as instructed under, "7. Steering Gear."

3. FRAMES

A basic ladder-type, box section frame is used on all Ford cars. All models except the Sunliner and Thunderbird have five frame cross members which are either welded or riveted to the side members. The Sunliner and Thunderbird have the "X" type cross member in the box frame. On all frames, a tubular cross member acts as a support for the engine and for the rear legs of the front suspension lower arms. The front cross member on the Thunderbird is also of the tubular type.

The Victoria and Crown Victoria frames have extra body mounting brackets, and capping strips are welded

along the bottom of the side members.

The basic frame is used on the Station Wagons and Courier except that one of the cross members is differently designed and located further to the rear. An additional body mount is located on the inside of each side member.

a. Checking Frame Alignment.

If the frame becomes misaligned due to a collision, stresses may result which can affect the normal operation of other chassis units. A misaligned frame can

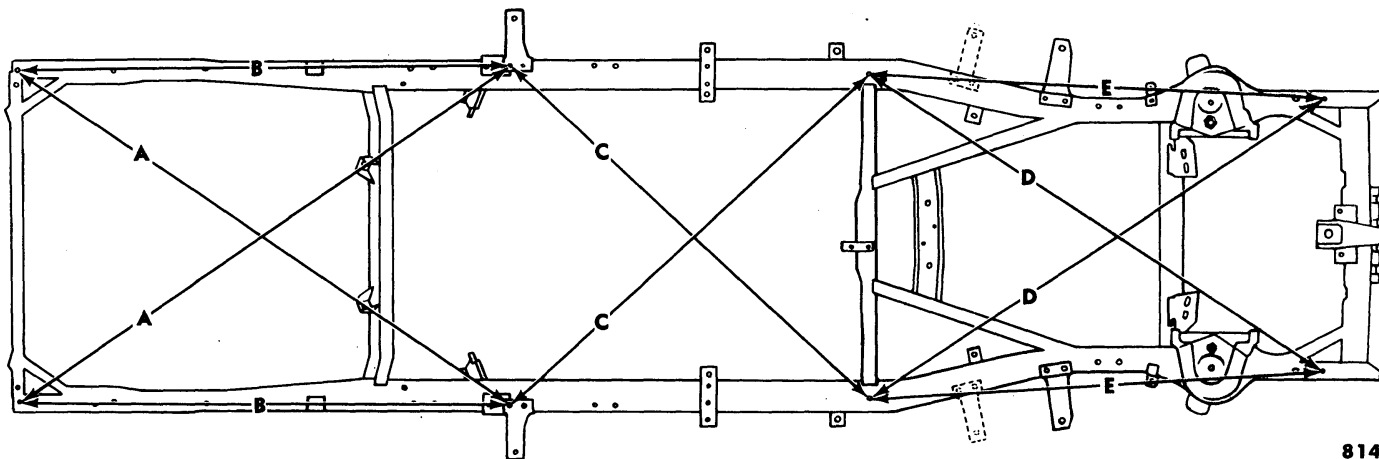

8144

Fig. 4—Frame Alignment

cause body and door opening misalignment.

If the car body is not removed from the frame, use the diagonal or "X" checking method to check the frame (fig. 4). When using this method, place the car on a level floor, and select points along one side of the frame, as shown in fig. 4, for which there are corresponding points on the opposite side of the frame. Transfer these points, with a plumb bob, from the frame to the floor. To insure accuracy, the points of measurement should be transferred very carefully.

b. Replacement.

If a damaged frame member is to be replaced, use

the same method of attachment as on the original frame member.

To replace parts attached with rivets, drill off the old rivet heads, then drive the rivets out of the parts to be replaced. Position the new parts in their correct locations, and secure them in place with hot rivets.

c. Frame Welding.

When welding frame members care must be taken to localize the heat so that the steel hardness will be retained. Therefore, all frame welding must be done with electrodes. When a reinforcement is to be welded to a frame side member, the welds must run lengthwise along the side of the reinforcement.

4. FRONT SUSPENSION

All cars are equipped with the ball joint-type independent front suspension (fig. 5).

The front wheel spindles are connected directly to the suspension upper and lower arms by means of ball joints located at the outer ends of the arms. The inner ends of the arms are pivoted in rubber torsion-type bushings which are pressed into the arms. The lower arms are bolted, through the bushings, to the frame cross members. The upper arms are supported by shafts which are bolted to brackets on the frame side members. Coil springs are mounted between the lower arms and the frame, and are controlled by telescopic, direct-action shock absorbers.

The working parts of the front suspension are assembled directly on the car frame and cannot be removed as an assembly. However, individual suspension parts may be replaced.

a. Replacement.

A disassembled view of the front suspension is shown in fig. 6, and should be referred to when using the replacement procedures.

NOTE: *Whenever any part of the front suspension has been replaced, be sure to check and adjust the camber, caster, and toe-in.*

(1) **COIL SPRING AND SUSPENSION LOWER ARM.** Raise the front of the car until the wheel clears the ground, then place a support under the frame to the rear of the suspension lower arm. Remove the front wheel. Remove the cotter pin from the lower ball joint nut, then loosen the nut one or two turns.

Place a box wrench over the lower end of the remover shown in fig. 7. Install the remover so that the tool seats firmly against the ends of the lower and

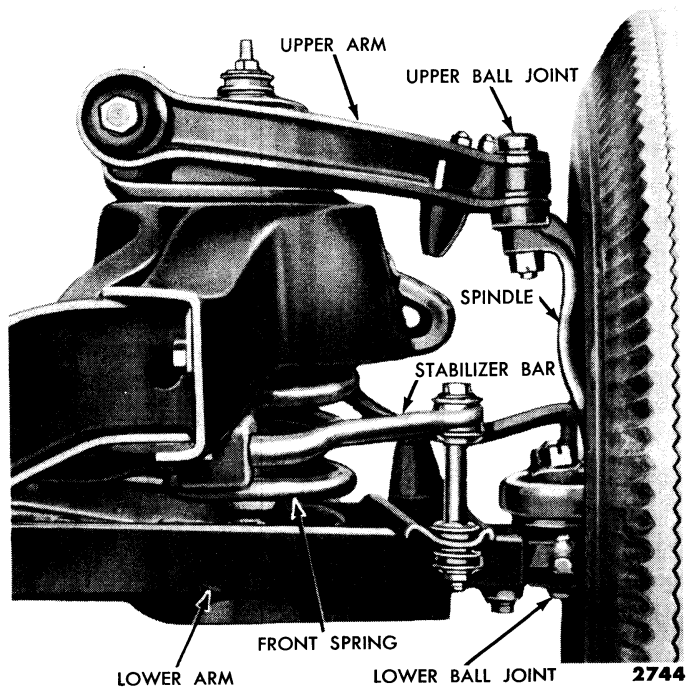

Fig. 5—Front Suspension—Left Side

upper studs, then apply enough screw pressure with the tool to place the ball joint studs under tension. Tap the spindle sharply near the ball joint with a hammer to loosen the stud from the spindle.

NOTE: Do not try to remove the stud from the spindle with the tool alone.

Disconnect the stabilizer bar from the lower arm. Remove the shock absorber. Place a jack under the suspension lower arm to prevent the arm from dropping down, then remove the lower ball joint nut. Lower the jack under the arm so that the coil spring can be removed from the spring seat. Remove the coil spring rubber insulator and retaining ring.

Remove the nuts and bolts that secure the lower arm to the frame cross members, remove the shims from the front bolt, then remove the lower arm.

Remove the lower ball joint assembly and the rubber bumper from the suspension arm. Inspect the lower arm for cracks or distortion. Replace the arm if it is cracked or bent. Inspect the lower arm rubber bumper and the coil spring rubber insulator for wear or deterioration, and replace them if necessary.

Inspect the lower arm inner bushings for wear or damage. If it is necessary to replace either bushing, remove both bushings with the tool shown in fig. 8. Be sure to position both halves of Detail No. 12 of the tool under the bushing flanges before pressing out the bushings. Install new bushings, being careful not to press them into the arm past the bushing shoulders (fig. 9).

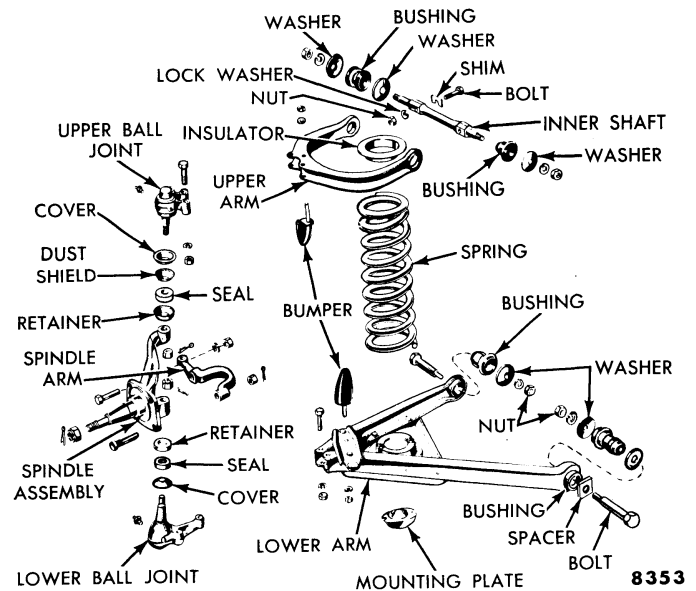

Fig. 6—Front Suspension—Disassembled

NOTE: Always replace both lower arm inner bushings, as a pair, at the same time.

Remove the retainer and seal and the cover from the suspension lower arm ball joint stud. Inspect the retainer, cover, and ball joint for damage, and replace them wherever necessary. Check the movement of the ball stud in the assembly with a spring scale attached at the cotter pin hole. If the pull required to move the stud is less than 8 pounds, replace the assembly.

CAUTION: Do not wash the ball joint with a solvent as greasing it properly may be difficult.

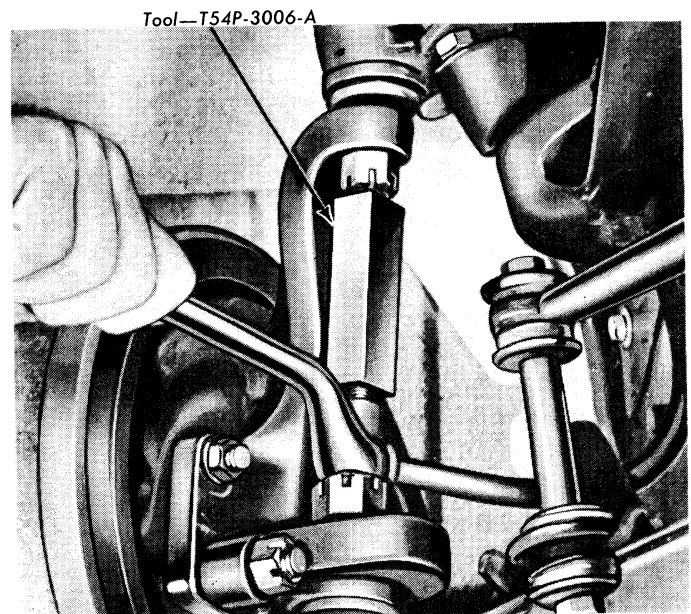

Fig. 7—Loosening Ball Joint Front Spindle

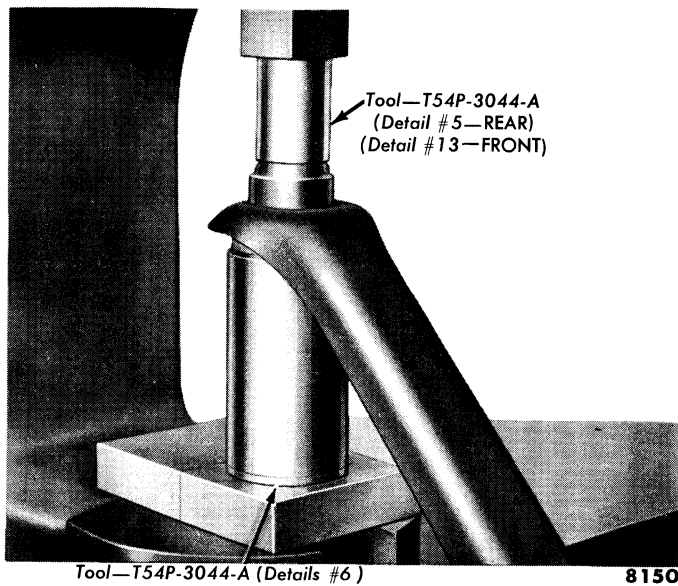

Fig. 8—Suspension Lower Arm Bushing Removal

Install a new rubber seal in the retainer, then position the cover and the retainer and seal on the ball joint stud. Install the ball joint assembly and the rubber bumper on the lower suspension arm. Tighten the ball joint assembly nuts to 65-90 foot-pounds torque. Tighten the bumper nut to 20-35 foot-pounds torque.

Install the lower arm rear leg bolt through the frame cross member, then position the rear leg on the bolt. Install the front leg bolt through the forward frame cross member. Add enough shims between the forward cross member and the front bushing to fill the existing space, then tighten the front and the rear nuts finger tight.

Position the rubber insulator on the top of the coil spring. On cars equipped with air conditioning, be sure

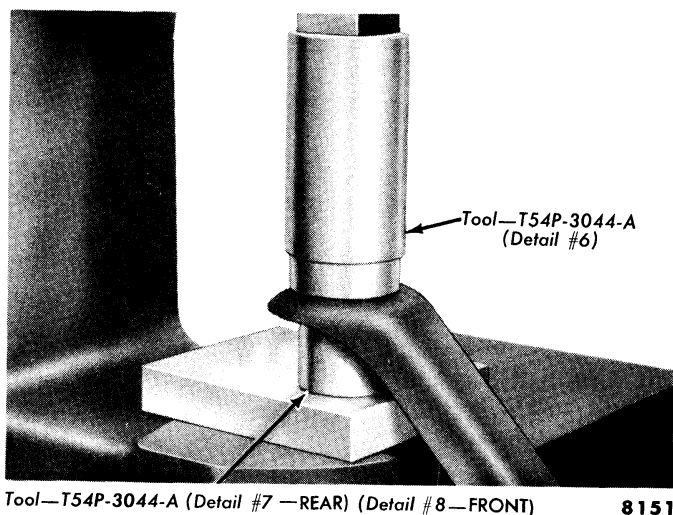

Fig. 9—Suspension Lower Arm Bushing Installation

to install a spring shim between the spring and the insulator. Tape can be used to hold the insulator and shim in place while installing the spring.

Insert the coil spring into position in the upper spring housing. Be sure that the flat end of the spring is facing upward. Place a jack under the lower arm and raise the arm so that the lower ball joint can be connected to the spindle.

Position the ball joint stud in the spindle, then install the nut. Tighten the nut to 100 foot-pounds torque, then continue to tighten until the cotter pin holes line up. Install a new cotter pin through the nut and stud.

Install the shock absorber. Connect the stabilizer bar to the suspension lower arm. Install the front wheel, then remove the support and jack from under the car. Tighten the nuts on the lower arm front and rear leg bolts to 55-75 foot-pounds torque.

NOTE: *Tighten the leg bolt nuts only when the suspension arms are in a normal load position.*

Check and adjust, if necessary, the camber, caster, and toe-in.

(2) **SUSPENSION UPPER ARM.** Remove the shield from the front fender apron. Place a jack under the suspension lower arm, and raise the front of the car until the wheel clears the ground. Place a support under the frame. Remove the front wheel. Attach a wire from the spindle to the frame to prevent damage to the brake hose. Remove the cotter pin from the upper ball joint nut, then back off the nut one or two turns. Loosen the upper ball joint stud from the spindle with the tool shown in fig. 7, and by tapping the spindle near the ball joint with a hammer. Remove the nut from the stud.

Remove the upper arm and the attaching bolts from the frame.

NOTE: *Measure and note the thickness of the shims on each bolt between the upper arm inner shaft and the frame.*

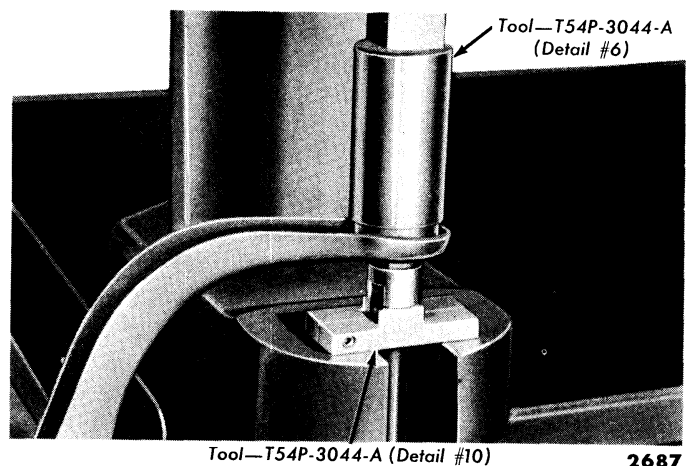

Fig. 10—Suspension Upper Arm Front Bushing Removal

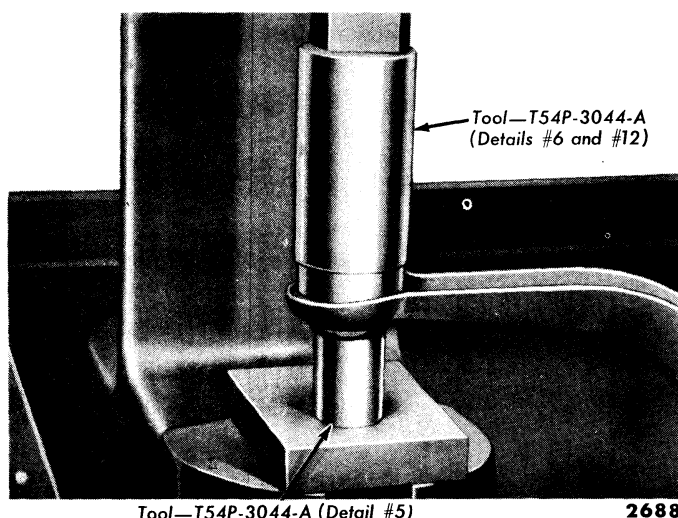

Fig. 11—Suspension Upper Arm Rear Bushing Removal

Remove the upper ball joint assembly and the rubber bumper from the upper arm. Inspect the arm for cracks or distortions, and replace it if necessary. Inspect the rubber bumper, and replace it if it is worn or damaged.

Inspect the upper arm inner shaft and bushings for wear or damage. If it is necessary to replace the shaft or either bushing, remove the nuts and washers from the inner shaft ends. Press out the upper arm front bushing as shown in fig. 10. Remove the inner shaft from the arm, then press out the rear bushing (fig. 11).

NOTE: Always replace both upper arm bushings, as a pair, at the same time.

Install the upper arm rear bushing as shown in fig. 12. Position the inner shaft in the upper arm so that the bolt holes are parallel to the arm, then install the front bushing (fig. 13). Install the washers and nuts on the inner shaft ends, and tighten them to 60-75 foot-pounds torque.

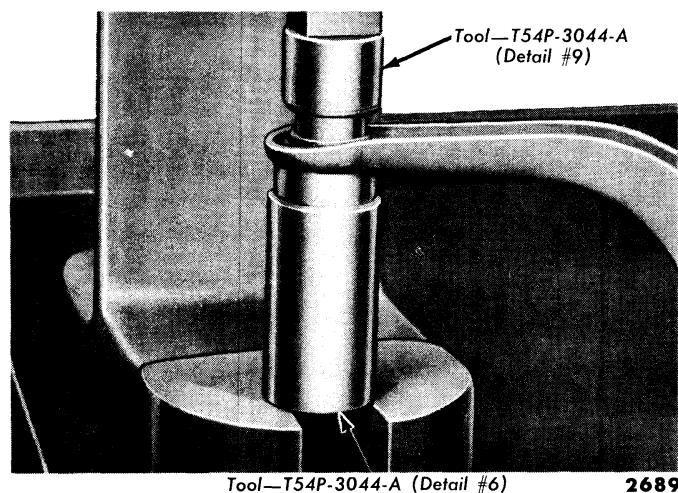

Fig. 12—Suspension Upper Arm Rear Bushing Installation

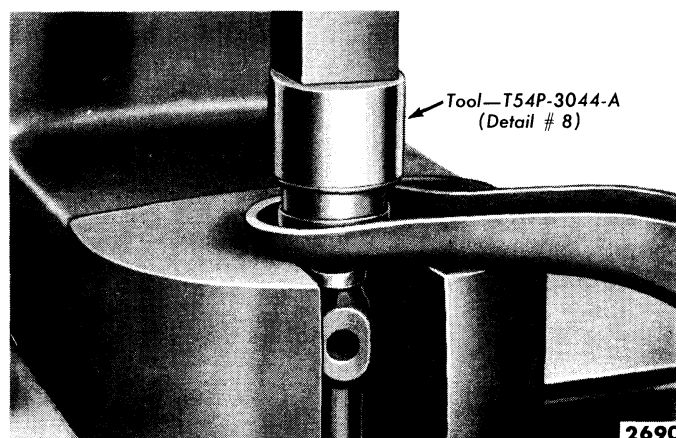

Fig. 13—Suspension Upper Arm Front Bushing Installation

Remove the retainer and seal and the covers from the upper arm ball joint stud. Inspect the retainer, covers, and ball joint for damage, and replace them if necessary. Turn the stud in the assembly with a torque wrench. If the effort required to turn the stud is not within 25-40 inch-pounds torque, replace the assembly.

CAUTION: Do not wash the ball joint with a solvent as regreasing it properly may be difficult.

Install a new rubber seal in the retainer, then position the covers and the retainer and seal on the ball joint stud. Install the ball joint assembly and the rubber bumper on the upper suspension arm. Tighten the ball joint assembly nuts to 28-45 foot-pounds torque. Tighten the bumper nut to 20-35 foot-pounds torque.

Position the upper arm and the attaching bolts on the frame, and position the upper ball joint stud in the spindle. Install the shims on each bolt behind the inner shaft.

NOTE: Install the same number and thickness of shims behind the inner shaft that were removed during disassembly.

Install the inner shaft to frame washers and nuts, and tighten the nuts to 65-90 foot-pounds torque. Install the shield on the fender apron. Install the nut on the upper ball joint stud. Tighten the nut to 80 foot-pounds torque, and continue to tighten it until the cotter pin holes line up. Install a new cotter pin through the nut and stud.

Remove the supporting wire from the spindle and the frame, then install the front wheel. Remove the support and the jack from under the car.

Check and adjust the camber, caster, and toe-in.

(3) **SPINDLE.** Place a jack under the suspension lower arm and raise the car. Remove the wheel and drum assembly. Remove the cotter pins and nuts from the spindle arm to spindle bolts, then remove the spindle arm (fig. 14). Remove the brake carrier plate, and

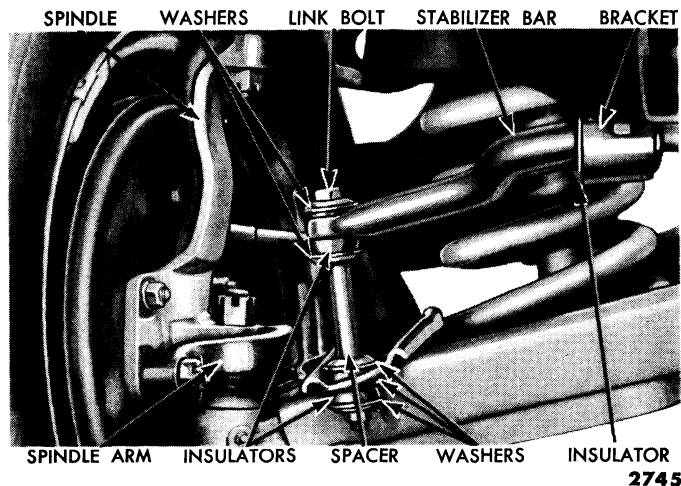

Fig. 14—Spindle and Stabilizer Installation

attach a wire from the plate to the frame to prevent damage to the brake hose. Remove the cotter pins from the upper and lower ball joint nuts, then loosen the lower stud nut. Position the remover (fig. 7), then apply pressure between the two studs. Tap the spindle sharply near the lower ball joint with a hammer to loosen the lower stud from the spindle. Remove the upper stud from the spindle in the same manner.

NOTE: *Do not try to remove both studs from the spindle with the tool alone.*

Remove the nuts from the studs, and remove the spindle from the studs.

Check the spindle for cracks or distortion, and replace it if it is cracked or bent.

Position the upper and lower ball joint studs in the spindle. Install the ball stud nuts, then tighten the upper nut to 80 foot-pounds torque and the lower nut to 100

foot-pounds torque. Continue to tighten both nuts until the cotter pin holes line up, then install new cotter pins.

Position the brake carrier plate and the spindle, and install the nuts. Tighten the upper nuts to 28-43 foot-pounds torque, and the lower nuts to 70 foot-pounds torque. Continue to tighten the lower nuts until the cotter pin holes line up, then install new cotter pins. Install the wheel and drum assembly. Remove the jack from under the car.

Check and adjust the camber, caster, and toe-in.

b. Stabilizer.

The stabilizer bar is held in place by two rubber insulators which are clamped to the frame side rails (fig. 14). The ends of the stabilizer bar are connected to both lower suspension arms by link bolts, spacers, washers, and rubber insulators.

(1) **REMOVAL AND DISASSEMBLY.** Remove the link bolts, spacers, washers, and insulators that connect the stabilizer bar to the lower suspension arms. Remove the stabilizer bar to frame bolts, brackets, and reinforcing plates. Remove the engine front splash shield from the frame, then remove the stabilizer bar. Slide the rubber insulators off the stabilizer bar.

(2) **ASSEMBLY AND INSTALLATION.** Coat the stabilizer bar insulators with hydraulic brake fluid or petrolatum, then slide the insulators into position on the stabilizer bar. Position the stabilizer bar on the frame, and install the reinforcing plates, brackets, and bolts that secure the bar to the frame. Tighten the bolts to 20-35 foot-pounds torque. Install the engine front splash shield. Install the link bolts, spacers, washers, and insulators on the stabilizer bar and the lower suspension arms. Tighten the link bolt lock nuts to 20-35 foot-pounds torque.

5. REAR SUSPENSION

The rear springs are of the rubber-mounted, semi-elliptic leaf type. All cars except the Station Wagons and Courier have five-leaf springs. Seven leaves are used on the Station Wagon and Courier rear springs.

The front end of each rear spring is mounted in a stationary hanger which is attached to the frame side member. The rear end of each rear spring is shackled to a shackle hanger bar which is bolted to the frame side member (fig. 15).

Each rear spring is attached to the rear axle housing with two "U"-shaped spring clips. Rubber insulating pads are installed between the top of the rear spring and the spring seat, and between the bottom of the spring and the spring clip plate (fig. 16).

The spring leaves are held together in alignment by the spring center bolt. Three rubber insulated spring

clamps are installed on each rear spring to maintain the alignment of the leaves. Wax-impregnated fabric inserts are installed between the outer ends of the adjacent leaves of each spring to eliminate spring squeak and to control interleaf friction. The rubber bushings installed at the spring hangers and shackles do not require lubrication at these points.

a. Removal.

Raise the rear of the car and place supports under the frame and rear axle. Disconnect the shock absorber at the rear spring clip plate. Remove the spring clip nuts and the spring clips (fig. 16), then remove the spring clip plate, spring insulators, and the insulator retainers (if used). Remove the nuts from the shackle bar studs and remove the outer shackle bar (fig. 15).

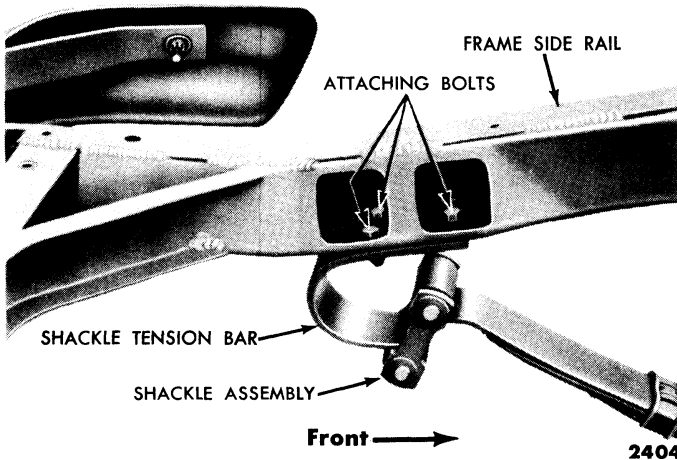

Fig. 15—Rear Spring Shackle Installation

Pull the rear spring off the lower shackle stud, then remove the spring from the car.

b. Inspection and Repair.

Inspect the rubber bushings, the hanger stud, the insulators, and the shackle studs for wear or damage. Replace parts where necessary. Pry the spring leaves apart and inspect the wax-impregnated inserts. Replace all worn inserts. Make sure the spring leaves are dry and free of oil before installing new inserts.

c. Installation.

Check the distances between each spring eye and the center tie bolt. Position the spring under the axle

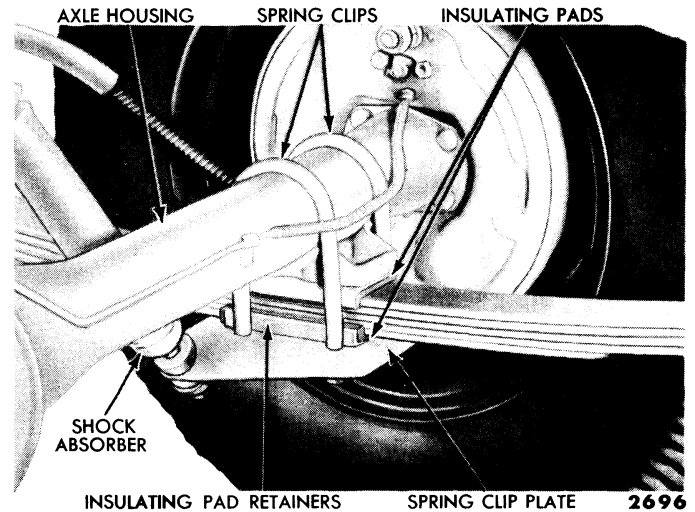

Fig. 16—Rear Spring Installation at Axle

housing with the shorter end toward the front of the car. Place the rear spring eye on the lower shackle bar stud, then install the seals, the outer shackle bar and the locknuts. Tighten the nuts securely. Position the spring insulators and insulator retainers on the spring, then position the spring clip plate under the spring and place the shock absorber stud in the hole in the plate. Install the spring clips and nuts. Tighten the nuts to 38-43 foot-pounds torque.

Install the front hanger stud and seals, tightening the stud nut securely. Connect the shock absorber at the spring clip plate. Jack up the rear of the car, remove the supports, then lower the car to the floor.

6. SHOCK ABSORBERS

Double-acting, telescopic, hydraulic shock absorbers are used on the front and rear of all cars.

The front shock absorbers are mounted inside the front suspension coil springs. The upper end of each shock absorber is attached to the frame, and the lower end is fastened to the front suspension lower arm. Both ends are insulated by rubber bushings.

The rear shock absorbers are installed between the rear spring and the frame cross member. The upper end of each shock absorber is attached to a bracket on the frame cross member, and the lower end is fastened to the rear spring clip plate.

The front and rear shock absorbers are nonadjustable and nonrefillable, and cannot be repaired.

a. Removal.

Before replacing a shock absorber, check the action of the shock absorbers by grasping the bumper and

jouncing the car up and down. If the shock absorbers are in good condition, the car will immediately settle to a normal position after the bumper is released. If the car continues to bounce, or remains displaced, remove the shock absorbers for further checking as follows:

To remove a front shock absorber, fig. 17, remove the locknut, washer, and rubber bushing from the upper stud at the top of the dome on the frame. Remove the bolts which retain the shock absorber mounting plate on the lower suspension arm and remove the shock absorber. Remove the locknut from the lower end of the absorber. Remove the bushings, retainers, and the mounting plate.

To remove a rear shock absorber, fig. 18, remove the lock nut from the shock absorber stud at the spring clip plate and at the frame cross member. Remove the washers and rubber bushings from the studs. Collapse the absorber, then remove it from the car.

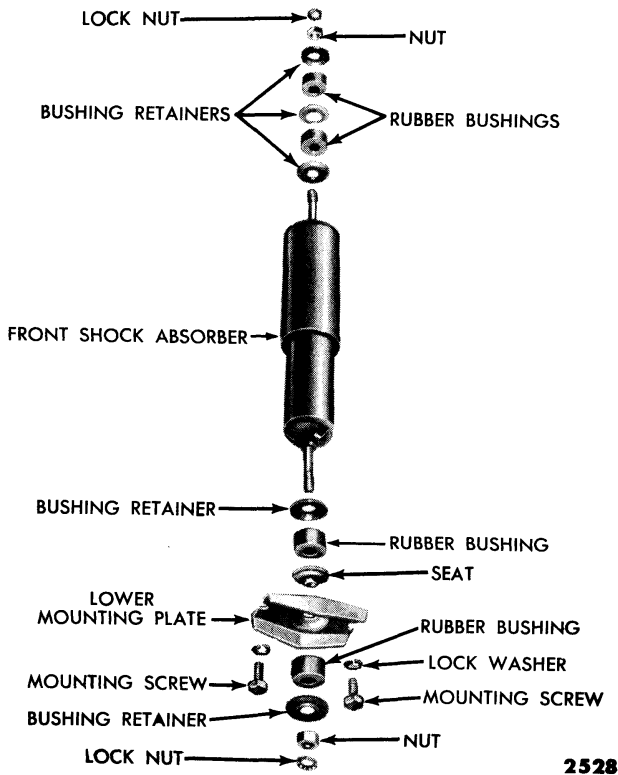

Fig. 17—Front Shock Absorber—Disassembled

b. Testing.

To check a shock absorber removed from a car, clamp the lower end in a vise in a near vertical position and pump it a few times to expel any air. A good shock absorber will have a steady drag in both directions when operated by hand. If it operates without any drag, or is very hard to operate, it should be replaced.

NOTE: *Front and rear shock absorber replacement kits are available. Each kit contains one shock absorber and four shock absorber bushings.*

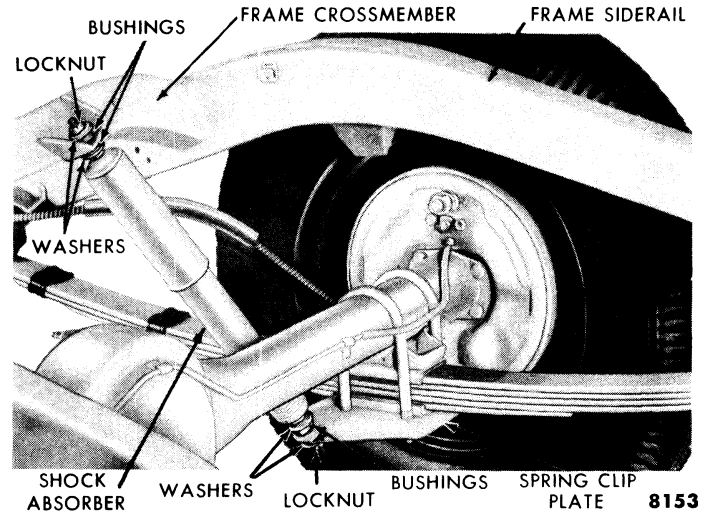

Fig. 18—Rear Shock Absorber Installation

c. Installation.

Place the washers, bushings, bushing seat, and mounting plate on the lower end of the shock absorber in the order shown in fig. 17, then install the stud lock nut. Tighten the nut to 25-35 foot-pounds torque. Place one washer and bushing on the upper end of the unit, then position the shock absorber in the coil spring. Install the lower mounting plate to frame bolts. Place the remaining bushing seat, bushing, and washer on the upper stud. Install the upper stud nut. Tighten the nut to 25-35 foot-pounds torque.

To install a rear shock absorber, proceed as follows:

Place one washer and one rubber bushing on each end of the rear shock absorber (fig. 18). Collapse the shock absorber, then position the unit on the car. Install the remaining bushing seats, bushings, and washers, then install and tighten the locknuts to 25-35 foot-pounds torque.

7. STEERING GEAR

A worm and roller type steering gear assembly is used on all models.

The steering gear assembly is mounted on the left frame side member. The steering column is held by a bracket to the lower side of the control panel.

The steering gear worm is integral with the steering shaft and is supported at each end by opposed tapered roller bearings (fig. 19). The roller is attached to the sector shaft by means of a steel shaft. Two needle bearing assemblies are installed between this shaft and the roller.

The sector shaft is mounted in the steering gear

housing on two needle bearing assemblies which are pressed into the housing. An adjustment screw, mounted in the housing cover, controls sector shaft end play and worm and roller mesh adjustment.

The steering wheel and sector shaft arm (Pitman arm) are splined to the steering shaft and sector shaft respectively. Both the sector shaft arm and the steering wheel have master splines to insure correct installation. The steering gear is designed so that when the steering wheel spokes are in their normal positions and at the mid-point of the steering wheel travel, the sector and worm will be at the high-point position.

DEFINITION: *The high point is the point of least clearance between the worm and roller and is at the mid-point of the worm and roller travel.*

a. Adjustments.

Three adjustments are required on the worm and roller type steering gear. They are (1) Worm Bearing Pre-Load, (2) Worm and Roller Mesh which automatically eliminates sector shaft end play and (3) Steering Wheel Spoke Position. The first two adjustments are made with the gear; the third adjustment is made independently of the gear.

Before proceeding with the steering gear adjustments, eliminate any misalignment of the steering column as follows:

Loosen the screws that fasten the steering gear housing to frame side rail to relieve any possible vertical strain. Loosen the steering-column-jacket clamp at the bottom of the control panel to relieve any possible horizontal strain. Tighten the steering gear mounting bolts, then tighten the clamp screws at the instrument panel to 5-7 foot-pounds torque. This relieves any misalignment in the mounting of the steering gear assembly to the frame and the body.

Steering gear adjustments must be made carefully and in the order given to insure satisfactory results.

(1) **STEERING GEAR WORM BEARING PRE-LOAD.** The worm bearing pre-load is controlled by the shim pack (gaskets) installed between the steering gear housing and the housing upper cap.

The shim pack contains shims of the following sizes: 0.002 inch, 0.005 inch, 0.010 inch, and 0.020 inch. The thinner shims are installed on the top of the pack. Adjust the pre-load as follows:

Disconnect the sector shaft arm from the steering arm to idler arm rod. Turn the steering wheel two complete turns from the straight-ahead position. Hook a spring scale to the steering wheel at the point where the spoke joins the steering wheel rim (fig. 20).

Rotate the wheel at least one turn with the aid of the scale. Note the pull required to keep the wheel moving. This reading is the worm bearing pre-load and should be between $\frac{1}{8}$ and $\frac{5}{8}$ pounds. If the reading is too high, excessive bearing pre-load is indicated and a shim or shims must be added.

If the reading is too low, the bearing pre-load is insufficient and a shim or shims must be removed.

If it is necessary to add or remove shims, remove the screws that secure the steering gear housing upper cap to the housing. Work the cap and column jacket upward to allow clearance for removing or adding shims. For additional working clearance, it may be necessary to remove the steering wheel.

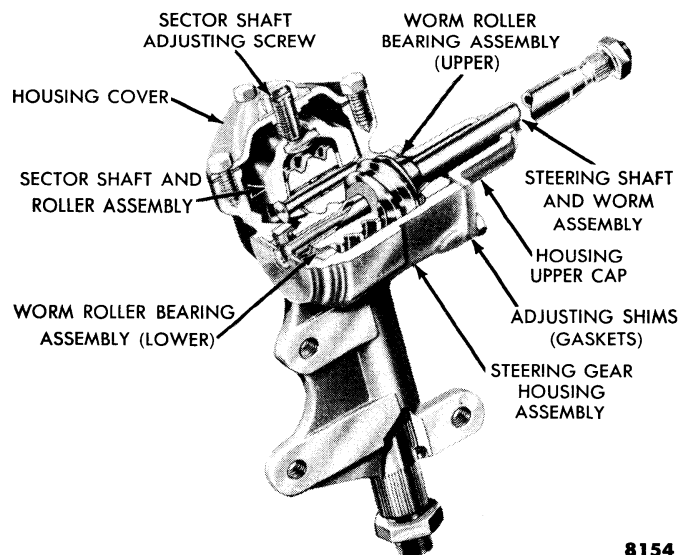

8154

Fig. 19—Steering Gear Assembly

To add a shim, split the shim at one point then install the shim with the split in the upward position. Make sure the split ends of the shim do not overlap as this could lead to a false pre-load reading.

To remove a shim, separate the first shim from the shim pack with a knife blade. Pass the knife blade all around the shim being careful not to damage the shims.

Remove or add one shim at a time. Check the worm bearing pre-load after each variation in the shim pack.

NOTE: *The steering column and the housing upper cap must be assembled on the steering gear housing each time the pre-load is checked.*

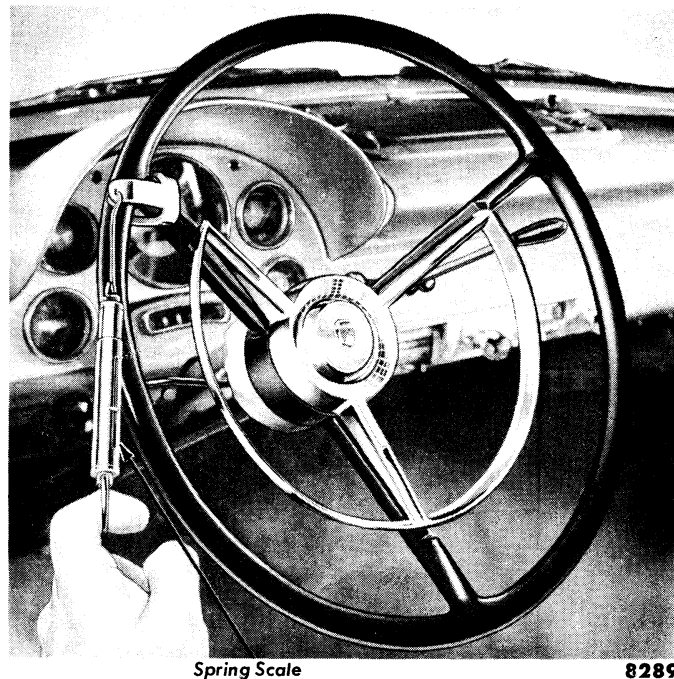

Spring Scale

8289

Fig. 20—Checking Worm Bearing Pre-Load

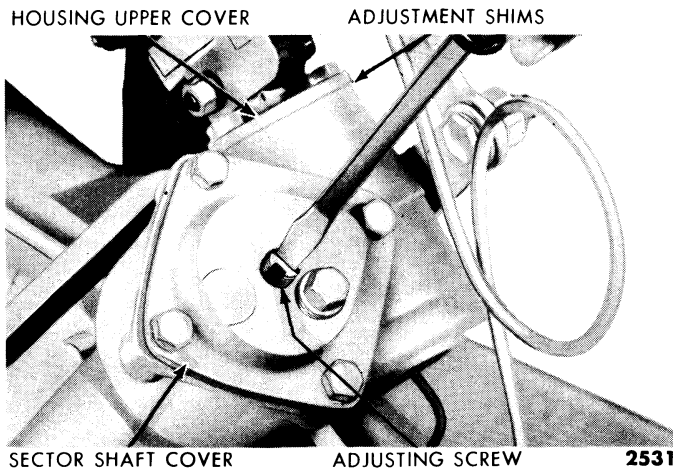

Fig. 21—Steering Gear Mesh Adjustment

(2) **STEERING GEAR WORM AND ROLLER MESH.** The worm and roller mesh adjustment is controlled by an adjustment screw mounted in the sector shaft cover. The body of the adjustment screw is threaded into the cover, and the head of the screw fits in a slot in the sector shaft. Thus, when worm and roller mesh is adjusted, sector shaft end play is eliminated. The worm and roller mesh is adjusted as follows:

Disconnect the sector shaft arm from the steering arm to idler arm rod. Attach a spring scale to the steering wheel rim as shown in fig. 20. Pull the wheel through the high-spot position (straight-ahead position) and note the reading on the scale. The scale reading should be at least $\frac{1}{2}$ pound above that of the worm bearing pre-load previously determined, but the total reading must not exceed $1\frac{5}{8}$ pounds. If the scale reading is within these limits no adjustment is needed. If the reading does not exceed the worm bearing pre-load by at least $\frac{1}{2}$ pound, there is insufficient roller mesh pre-load and the worm and roller should be adjusted.

Place the steering wheel in the straight-ahead position. Remove the adjusting screw cover and lock washer. Rotate the adjusting screw clockwise (fig. 21)

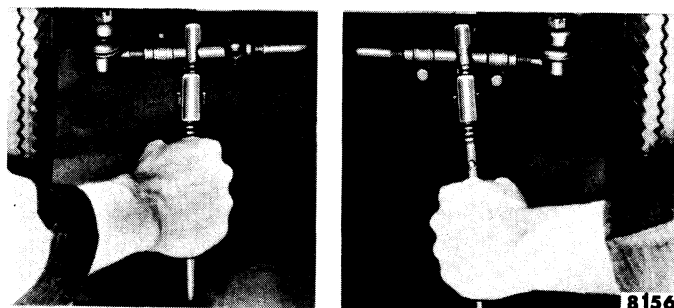

Fig. 22—Steering Wheel Spoke Adjustment

while moving the steering gear arm back and forth until all backlash is removed.

Install the adjusting screw lock washer with the tang on the washer engaged with the slot in the adjusting screw, and one of the serrations in the washer positioned over the boss in the housing cover. Check the pre-load with the spring scale as described previously. The reading should be between 1 and $1\frac{5}{8}$ pounds. This is the sum of the worm bearing pre-load and the gear mesh load. If the reading is too high, turn the adjusting screw slightly counterclockwise, and if the reading is too low, turn the screw in the clockwise direction.

After the foregoing adjustments have been completed, install the adjusting screw lock washer and cover. Install the sector shaft arm in the steering arm to idler arm rod.

(3) **CHECK AND ADJUST STEERING WHEEL SPOKE POSITION.** When the steering gear is on the high point, the front wheels should be in a straight-ahead position, the spokes of the steering wheel in their normal position, and the sector shaft arm pointing directly forward. Check the steering wheel spoke position when the car is driven straight ahead. If the spokes are not in a normal position, adjust as follows:

Set the bottom steering wheel spoke in the vertical position. Scratch a mark on each spindle connecting rod sleeve and the spindle connecting rod tube, then loosen the sleeve clamp bolts.

If the bottom steering wheel spoke was at the right of vertical position when checked, turn both connecting rod sleeves downward the same amount as shown in fig. 22. One complete turn of both sleeves equals approximately three inches of steering wheel rim travel. Turn both connecting rod sleeves upward if the bottom wheel spoke is at the left of the vertical. Tighten the sleeve clamp bolt nuts to 12 to 15 foot-pounds torque.

Road test the car and check the operation of the steering gear under all driving conditions.

b. Steering Gear Repair.

If the steering gear parts are worn to the extent that the gear cannot be properly adjusted, the gear must be removed from the car, completely disassembled, and the worn parts replaced.

(1) **STEERING WHEEL REPLACEMENT.** Disconnect the electrical wires at the bottom of the steering gear housing. Remove the horn button or ring by pressing down and turning the button or ring counterclockwise. Lift the spring from the steering wheel hub. Pull the horn wire and contact assembly out of the steering gear shaft. Remove the steering wheel nut, then remove the steering wheel as shown in fig. 23.

To install the steering wheel, position the wheel on the shaft with the master splines in alignment, then install the steering wheel nut. Tighten the nut to 50-60 foot-pounds torque. Install the horn wire in the steering shaft. Place the horn button or ring on the steering wheel hub and turn the button or ring clockwise to secure it to the steering wheel. Connect the horn wire to the connector at the bottom of the steering gear housing.

(2) **STEERING GEAR REMOVAL.** The procedures for removing the Thunderbird steering gear from the car differ from the procedures used on all other models.

(a) **CONVENTIONAL STEERING GEAR.** Remove the steering wheel, then disconnect the steering column from the control panel. Disconnect the gear shift levers from the gear shift rods.

Remove the cap screw from the bracket that secures the gear shift tube to the steering column tube and remove the bracket. Remove the gear shift tube pin and the gear shift levers. Loosen the steering column clamp, and pull the steering column tube assembly off the steering gear shaft. Disconnect the steering arm from the steering arm to idler arm rod. Remove the sector shaft arm as shown in fig. 24. Remove the three bolts that secure the steering gear housing to the frame side member. Remove the steering gear from the car.

NOTE: *It may be necessary to raise the car to remove the steering gear.*

(b) **THUNDERBIRD STEERING GEAR.** Disconnect the wires at the bottom of the steering gear housing. Loosen the lower steering column clamp, then remove the two screws from the upper steering column bracket.

Remove the horn ring from the steering wheel. Remove the upper steering column, upper steering shaft, and steering wheel as an assembly from the car.

Raise the front of the car. Remove the steering sector shaft arm from the sector shaft, then remove the bolts that hold the steering gear housing on the frame side member. Remove the lower steering gear assembly from the car.

(3) **STEERING GEAR DISASSEMBLY.** Drain the lubricant from the steering gear housing. Remove the sector shaft and cover (fig. 25) from the housing. Remove the cover and adjusting screw from the sector shaft, then remove the gasket from the housing.

Remove the steering gear housing cap screws and slide the cap off the steering gear shaft. Pull the steering gear shaft and worm assembly out of the steering gear housing. Slide the steering gear housing upper cap gaskets (shim pack), bearing cup, and upper worm

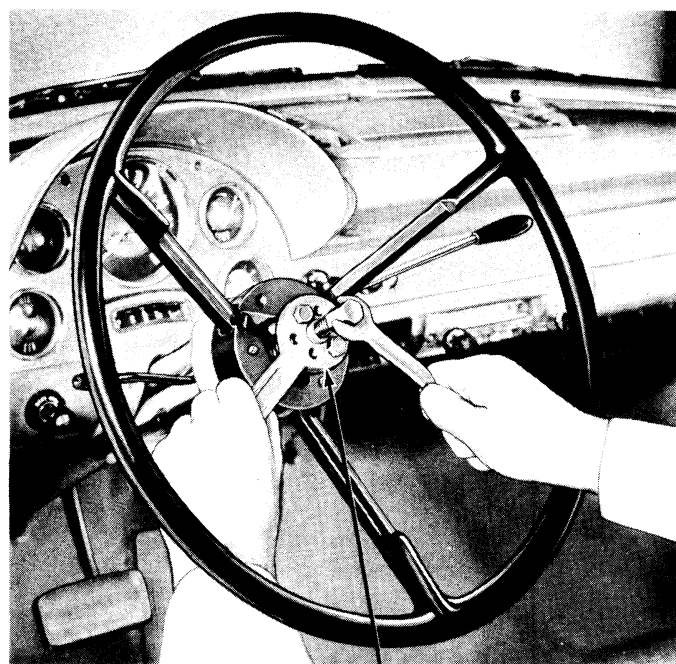

Steering Wheel Puller—3600-N 8323

Fig. 23—Steering Wheel Removal

bearing out of the housing, then remove the bearing cup with the tool shown in fig. 26.

Press the sector shaft needle bearings and oil seal out through the steering arm end of the steering gear housing with the tool shown in fig. 27.

(4) **STEERING GEAR INSPECTION.** Clean all parts thoroughly, then inspect the worm and the roller for scores, cracks, or for signs of chipping. Inspect the steering shaft bearing cups and bearings for wear, cracks, or damage. Check the sector shaft for wear at the needle bearing locations. Replace all parts that are damaged enough to impair steering gear operation.

(5) **STEERING GEAR ASSEMBLY.** Press the bearings into the sector shaft housing (fig. 28). Press the oil

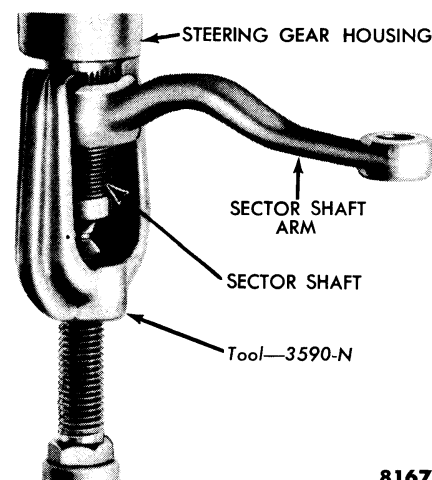

8167

Fig. 24—Sector Shaft Arm Removal

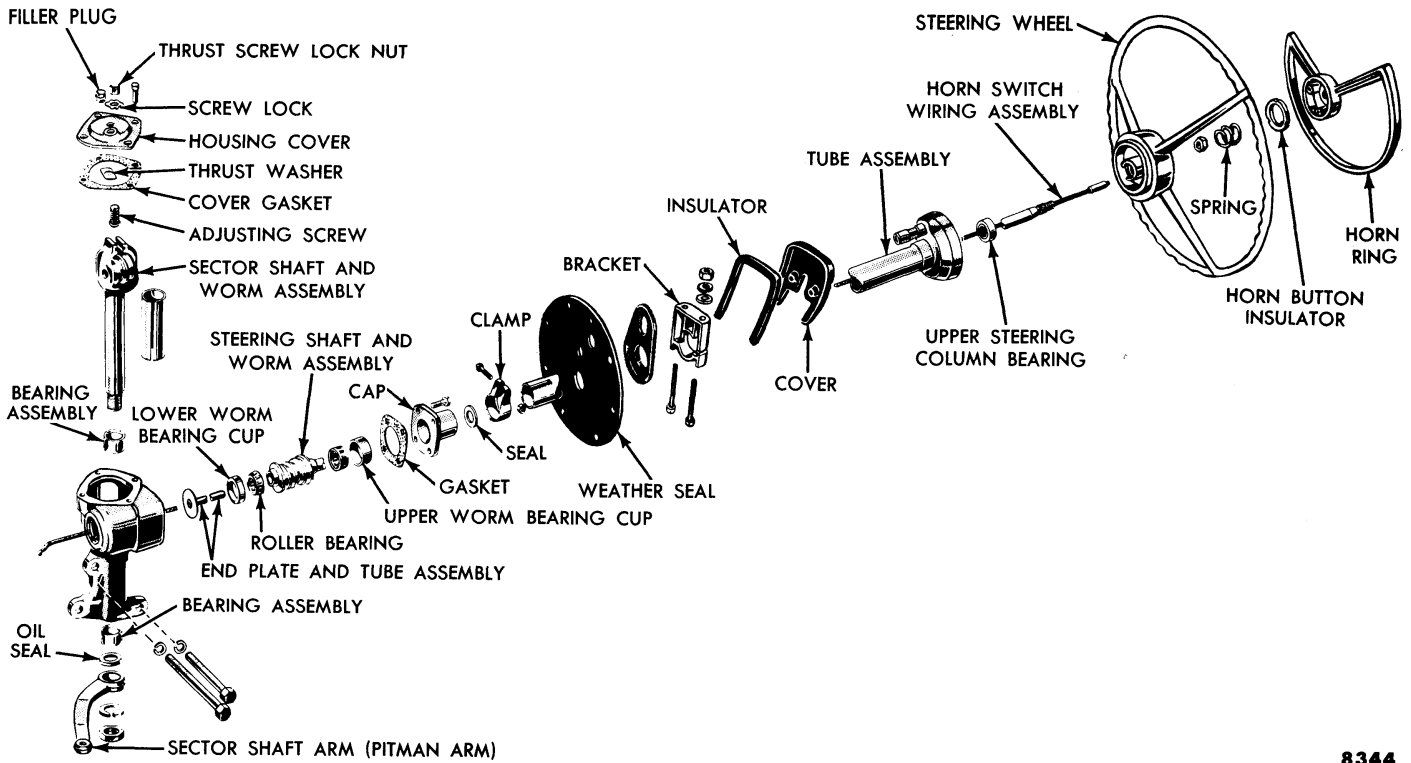

8344

Fig. 25—Conventional Steering Gear—Disassembled

seal into the sector shaft arm end of the sector shaft.

Position the upper worm bearing, the bearing cup, and the steering gear housing upper cap gaskets (shim pack) on the worm and shaft assembly. Slide the steering gear housing upper cap on the steering shaft. Install the lower worm bearing cup with the tool shown in fig. 29, then install the bearing in the steering gear housing.

Position the steering gear shaft and worm assembly in the steering gear housing and install the cap screws. Tighten the cap screws to 12-15 foot-pounds torque. Position a new steering sector shaft cover gasket on the steering gear housing. Position the adjusting screw and cover assembly on the sector shaft, then slide the steering sector shaft assembly into the steering gear housing.

Install the steering sector shaft cover attaching bolts and lock washers, then tighten the bolts to 12-15 foot-pounds torque.

(6) **STEERING GEAR INSTALLATION.** The procedures for installing the Thunderbird steering gear differ from the procedures used on all other models.

(a) **CONVENTIONAL STEERING GEAR.** Position the steering gear assembly on the frame side member. Install but do not tighten the mounting bolts and nuts. Install the steering column tube assembly on the steering shaft. Secure the steering column tube bracket to the control panel with the two cap screws. Tighten the cap screws to 5-7 foot-pounds torque, then tighten the steering gear housing to frame bolts to 30-35 foot-pounds

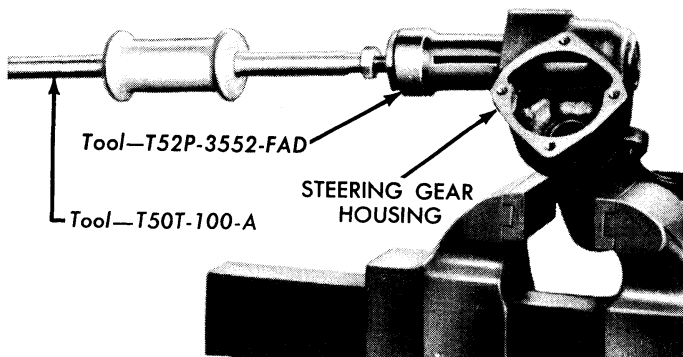

2567

Fig. 26—Lower Worm Bearing Cup Removal

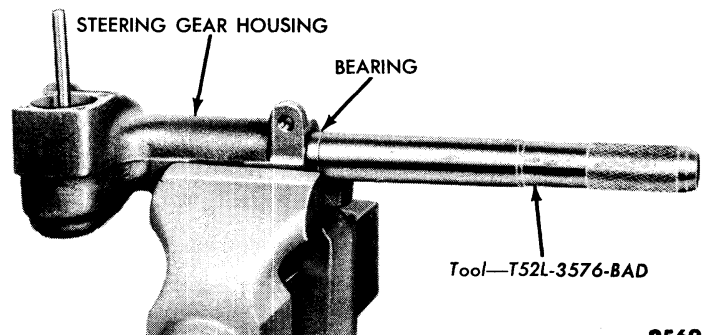

2569

Fig. 27—Sector Shaft Bearing Removal

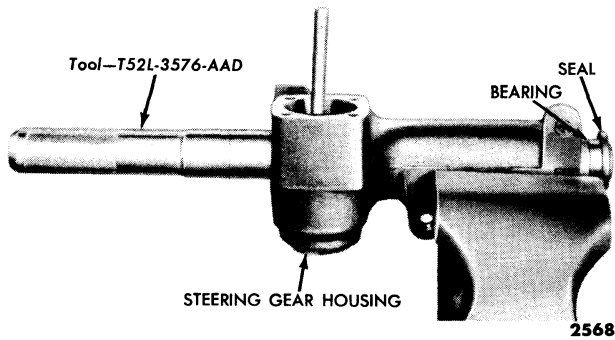

Fig. 28—Sector Shaft Bearing Installation

torque. Install the pin and the lower gear shift levers.

Place the gear shift tube bracket in position and secure the tube in place with a cap screw. Connect the gear shift levers to the gear shift rods, then install the steering wheel. Position the sector shaft arm on the steering sector shaft.

NOTE: *The arm should be installed pointing straight forward when the wheel spokes are in the normal position and the worm is at mid-point of travel.*

Install and tighten the lock washer and nut to 110-130 foot-pounds torque. Install the sector shaft arm in the steering arm to idler arm rod ball socket. Fill the steering gear housing to the filler plug level with the proper lubricant. Adjust the steering gear.

(b) THUNDERBIRD STEERING GEAR. Position the lower steering gear assembly on the frame side member. Install but do not tighten the mounting bolts and nuts. Remove the screws from the steering column upper bracket cover plate, then tape the bracket and plate to the upper steering column.

Align the splines in the upper and lower steering shafts, then install the upper steering column, upper steering shaft, and steering wheel as an assembly in the car. Position the upper steering column bracket on the control panel, but do not tighten the screws. Position

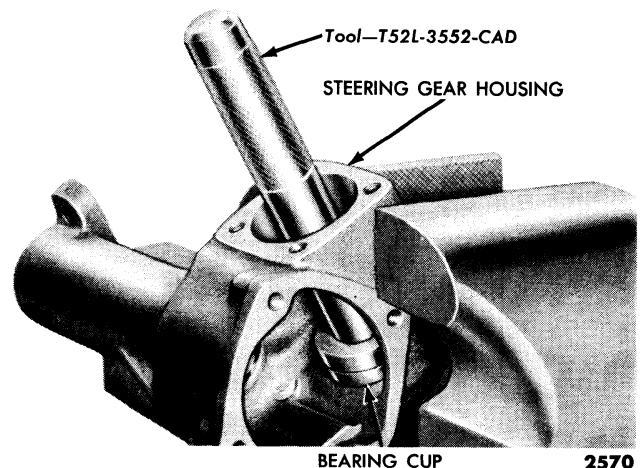

Fig. 29—Lower Worm Bearing Cup Installation

the gasket on the cover plate, then install the plate on the bracket. Tighten the bracket mounting screws to 5-7 foot-pounds torque.

Install the horn wire in the steering column, then install the horn ring on the steering wheel. Connect the directional signal wires.

Position the steering wheel in the straight-ahead position, then install the sector shaft arm on the bottom of the shaft, and tighten the nut to 110-130 foot-pounds torque.

NOTE: *The arm should be installed pointing straight forward when the wheel spokes are in the normal position and the worm is at mid-point of travel.*

Tighten the steering gear housing bolts and nuts to 30-35 foot-pounds torque. Lower the car to the floor, then tighten the lower steering column clamp.

Connect the electrical wires at the bottom of the steering gear housing, then check the operation of the horn and the directional signal lights.

Fill the steering gear housing to the filler plug level with the proper lubricant. Adjust the steering gear.

8. STEERING LINKAGE

The steering linkage consists of the sector shaft arm (Pitman arm), the steering arm to idler arm rod, the right and left-hand spindle connecting rods (tie rods), the spindle arms, and the steering idler arm and bracket (fig. 30).

The sector shaft arm is splined to the steering sector shaft. A master spline is provided on the sector shaft arm and in the sector shaft to assist in proper sector shaft arm installation.

The sector shaft arm is attached to the steering arm

to idler arm rod by means of a ball stud which seats in the ball socket on the end of the steering arm to idler arm rod. The ball seat, in the steering arm to idler arm rod ball socket, is spring-loaded to automatically compensate for wear. When the limit of this automatic adjustment has been reached, the ball socket must be manually adjusted.

The spindle connecting rod ends are equipped with non-adjustable, spring-loaded ball studs which automatically compensate for wear. When the limit of this

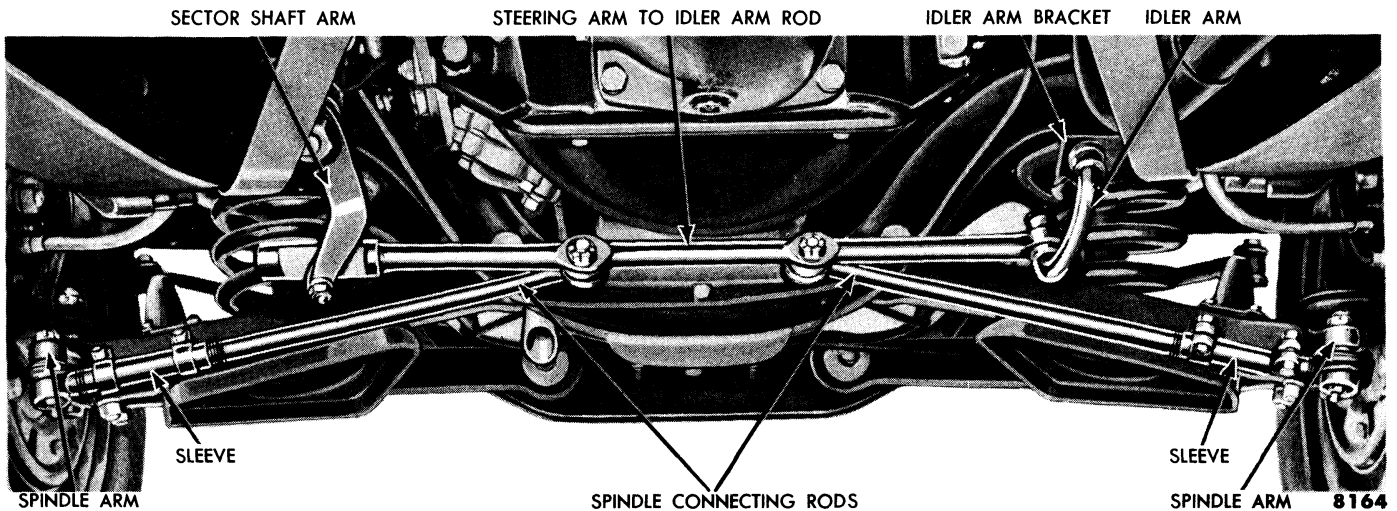

Fig. 30—Conventional Steering Linkage

automatic wear adjustment has been reached, the rod ends must be replaced.

If the steering arm to idler arm rod is bent or damaged, the entire rod assembly must be replaced. Since the inner spindle connecting rod ends are part of the right and left-hand spindle connecting rods, the rods must be replaced when the rod ends become worn.

The right hand end of the steering arm to idler arm rod is attached to the idler arm by means of a bushing which is threaded into the rod and onto the idler arm. The other end of the idler arm is attached to the idler arm bracket in the same manner. The idler arm bracket is bolted to the frame side rail.

a. Ball Socket Adjustment.

Adjustment of the steering arm to idler arm rod ball socket is required whenever the sector shaft arm ball stud is found to have end play in the ball socket.

Remove the cotter pin from the end of the rod. Tighten the threaded plug in the end of the socket until all ball stud end play is removed. Back off the threaded plug approximately $1\frac{1}{2}$ turns, then install a new cotter pin. Test the adjustment by turning the steering arm to idler arm rod by hand. The rod should move freely without bind, but there should be no end play at the ball stud.

b. Rod End Replacement.

The outer spindle connecting rod ends should be replaced when they become worn.

If the ball seats in the steering arm to idler arm ball sockets are worn to the extent that a manual adjustment will not eliminate ball stud end play, the ball seat must be replaced.

(1) **SPINDLE CONNECTING ROD ENDS.** Remove the cotter pins and nuts which attach the spindle connecting rod ends to the spindle arm (fig. 31). Support the spindle arms near the spindle connecting rod end studs, then drive the studs out of the arms using a soft metal hammer. Loosen the connecting rod sleeve clamp bolts, then remove the rod ends from the spindle connecting rod sleeve.

Thread each new end an equal distance into the spindle connecting rod sleeve. Place new seals on the connecting rod end ball studs. Position the end studs in the spindle arm holes, then install and securely tighten the attaching nuts. Install the new cotter pins. Adjust the front wheel toe.

(2) **STEERING ARM TO IDLER ARM ROD BALL SEATS.** Remove the cotter pin from the ball socket, then unscrew the threaded plug. Pull the socket off the steering arm ball stud. Remove the ball stud seats, springs, and spring guides from the socket (fig. 31). Clean all parts thoroughly with a suitable solvent. Replace all parts that are worn or damaged.

Install the spring guides, springs, and ball stud seats in the order shown in fig. 31. Position the ball socket on the steering arm ball stud, then install the threaded plug in the socket. Adjust the ball socket properly, then install a new cotter pin.

c. Rod Replacement.

The spindle connecting rod and the steering arm to idler arm rod should be replaced if they become worn or damaged.

(1) **SPINDLE CONNECTING ROD.** Remove the cotter pin and nut which attach the spindle connecting rod end to the steering arm to idler arm rod (fig. 31).

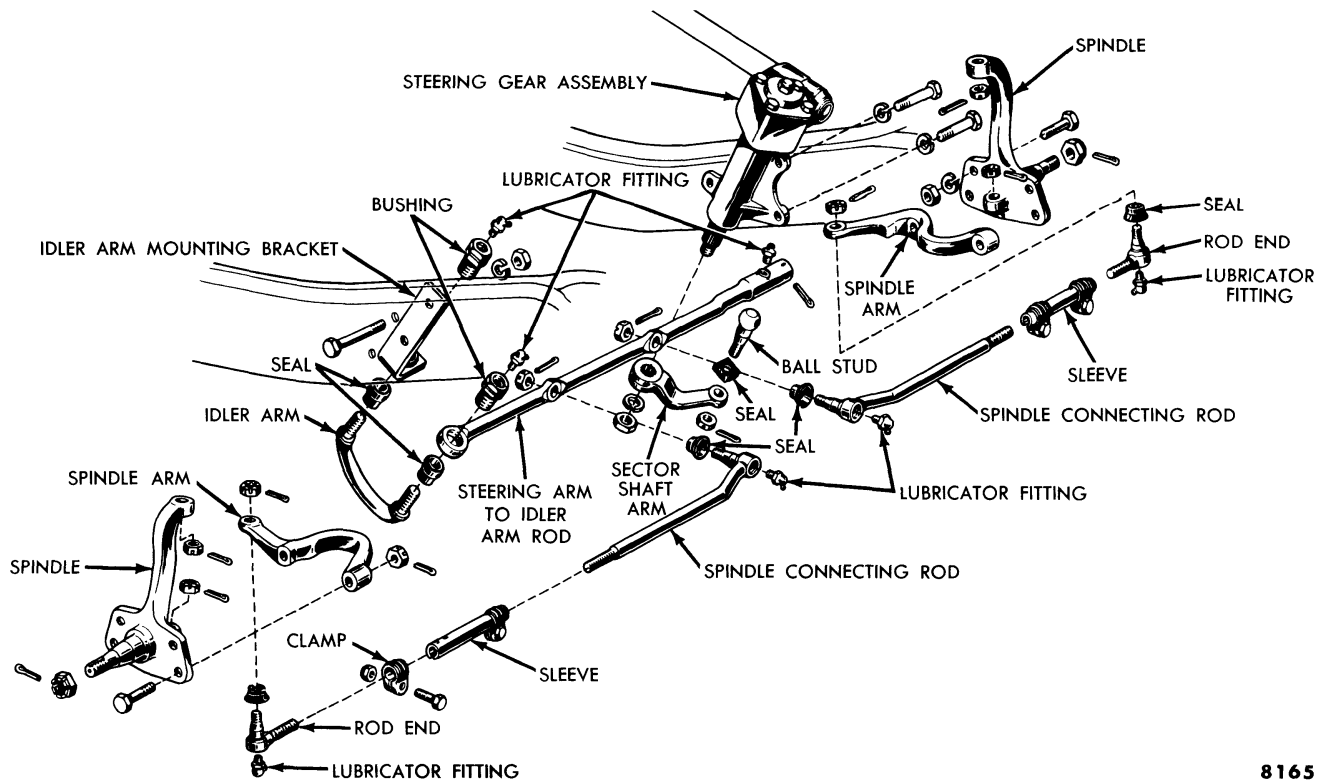

Fig. 31—Conventional Steering Linkage—Disassembled

8165

Support the idler arm rod near the ball stud, then tap the stud out of the arm. Loosen the spindle connecting rod sleeve clamp bolts, then remove the rod from the sleeve.

Thread the new spindle connecting rod into the sleeve. Connect the rod end ball stud to the steering arm to idler arm rod. Tighten the nuts to 50-60 foot-pounds torque, then install a new cotter pin. Adjust the toe.

(2) **STEERING ARM TO IDLER ARM ROD.** Remove the cotter pin and threaded plug from the steering arm to idler arm rod ball socket, then pull the socket off the sector shaft arm ball stud. Remove the cotter pins and nuts which attach the spindle connecting rod ends to the idler arm rod. Remove the idler arm rod from the idler arm.

Insert the new steering arm to idler arm rod on the idler arm. Insert the spindle connecting rod ends in the holes in the idler arm rod, then install the attaching nuts and cotter pins. Position the idler arm rod ball socket on the steering arm ball stud, then install the threaded plug in the socket. Adjust the ball socket properly, then install a new cotter pin. Check and adjust toe.

d. Steering Idler Arm.

The steering idler arm is designed to operate with $\frac{1}{8}$ -inch vertical free play when assembled to the steering linkage. If the vertical free play exceeds this limit, the

free play may be reduced by using the following procedure. This procedure should also be followed when replacing the idler arm or the idler arm bushings.

Remove the idler arm bracket from the frame side member.

Thread the bracket and bushing off the idler arm, then remove the idler arm rod. Remove the bushings from the idler arm bracket and the steering arm to idler arm rod, then remove the lubrication fittings from the bushings. Check the face of the side member for squareness as follows:

Place the car on a level floor, then measure the distance from each side member to the floor. If the distances are unequal, jack up the lowest side member until it is even with the other member. Place a spirit level against the inside surface of the right hand side rail, adjacent to the idler arm bracket position, then establish the true perpendicular. Measure the distance between the edge of the level and the side rail. This distance represents the amount of spacing washers which must be installed between the bracket and the side rail to correctly position the idler arm bracket.

Check the idler arm bracket for the 92° included angle and correct the angle if necessary.

Replace the idler arm bushings if either the internal or external threads show excessive wear or damage. Replace the idler arm if the threads are worn, and re-

place the bracket if it is badly damaged.

Install the idler arm bushings in the idler arm bracket and in the steering arm to idler arm rod. Tighten the bushings to 85-100 foot-pounds torque. Install the grease fitting in each bushing, positioning each fitting so that it is accessible for greasing.

Place new seals on the idler arm. Thread the idler arm into the idler arm rod bushing until the shoulder on the arm is $1\frac{1}{32}$ inch (plus or minus $\frac{3}{64}$ inch) from the top

face of the rod when the arm is in the straight-ahead position.

Thread the bracket and bushings assembly onto the idler arm until the shoulder on the arm is $1\frac{1}{32}$ inch (plus or minus $\frac{3}{64}$ inch) below the bottom side of the bracket when the bracket is parallel to the frame side rail. Mount the idler arm bracket on the frame side rail installing the necessary spacing washers between the bracket and the frame. Tighten the attaching bolts to 30-35 foot-pounds torque.

9. WHEELS AND TIRES

The wheels used on all models are steel disc stampings which are riveted to the rim. Tubeless tires are installed, as standard equipment, on all models.

a. Wheel Replacement.

Wheel stud nuts should be inspected and tightened regularly to avoid accidental loosening of the wheels. Failure to keep the wheel stud nuts tight might result in elongation of the stud holes in the wheels or other damage.

On new cars or after each wheel removal, check and tighten the wheel stud nuts after the first 100 miles of service. After each wheel removal, remove dirt, grease, or other foreign material from mating surfaces of the wheel and hub. Be sure the wheel stud nuts are free from grease or dirt.

With the car jacked up, install the wheels and stud nuts. Tighten the nuts enough to hold the wheel firmly in position. Always tighten opposite nuts to draw the wheel evenly against the hub.

Lower the car to the ground and tighten the nuts to 65-75 foot-pounds torque.

b. Tire Maintenance.

Maintenance of the correct inflation pressure is one of the most important elements of tire care. The inflation pressure recommendations for each car model must be followed to obtain the best car performance and tire life.

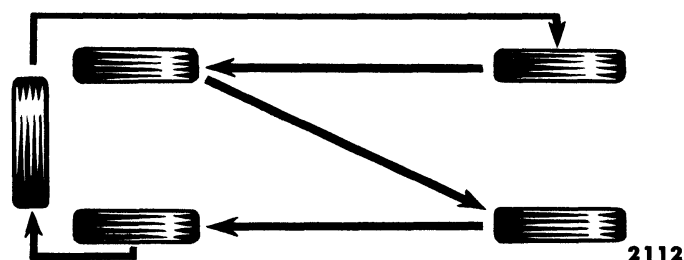

Fig. 32—Tire Rotation Diagram

Under-inflation causes excessive wear on the shoulders of the tire tread and over heating. Overinflation weakens the tire cords, makes the tire more susceptible to bruising, and is the cause of much tire failure.

Equal air pressure should be maintained in all tires on the same axle. Unequal pressure in front tires may cause hard steering. Unequal pressure in rear tires may result in loss of braking efficiency and weaving of the car.

Tire inflation pressures by tire size and car model are given in Specifications.

Tires should be cross-switched twice a year or every 5000 miles as shown in fig. 32. This permits the use of the spare tire on the road and prevents deterioration of the spare tire caused by lack of use. Always check the wheel balance each time the tires are cross-switched.

In the event of spotty wear on the front tires, cross-switching puts the front tires on the rear wheels where they again become round and true.

c. Tire Replacement.

Certain general precautions should be taken when removing or installing tubeless tires. These are as follows:

Always be sure the tire is completely deflated before attempting to remove the tire from the rim.

Be careful not to damage the tire bead when using tire irons to remove or install the tire on the rim.

Position the tire on the rim with the tire balance mark next to the valve in the rim.

After the tire has been mounted on the rim, inflate the tire to the recommended air pressure, then deflate and again inflate the tire to the recommended air pressure. This procedure will eliminate the possibility of the tire being improperly seated on the rim.

When mounting a tire, coat the tire beads with a vegetable soap and water solution. This makes it easier to force the beads over the edge of the wheel, both when the tire is mounted and when it is demounted

again. It also protects the beads from damage.

The drop center rim is used with all car tires. The well in the center of the rim provides the space for the tire beads during tire removal.

A 5-degree tapered bead seat on this type rim allows the tire bead to fit together, prevents rust and corrosion of the rim, and allows the beads to loosen easily during tire removal.

(1) **TIRE REMOVAL.** To remove the tire from a drop center rim, remove the valve core and deflate the tire completely.

The tire can be demounted with a mounting machine. If tire irons are used to demount the tire, first break the tire beads from the rim flanges with a bead loosening tool (fig. 33). Take small "bites" around the flanges with the tire irons to prevent injury to the tire beads.

Insert two tire irons about eight inches apart between the tire bead and the wheel rim and pry a short length of the bead over the wheel rim. Leave one tire iron in position and pry the rest of the tire bead over the wheel rim with the other tire iron. Stand the wheel upright with the bead in the drop center part of the rim at the bottom. Insert the tire iron between the bead and the wheel rim at the top side of the wheel, and pry the wheel out of the tire.

(2) **TIRE MOUNTING.** Examine the tire and the rim before mounting. Check the rim flange for dents, high spots, or other defects. If the rim is riveted to the wheel, check for loose rivets.

Be sure the tire beads and the rim are both clean and free of tire mounting compound. Dirt or rust can be removed from the rim with emery cloth or fine steel wool.

When mounting the tire, always apply mounting compound completely around the beads to insure a good air seal.

The tire can be mounted with a mounting machine. A mounting band should be used to force the tire beads against the rim flanges to create the initial seal (fig. 34). If a mounting band is not available, tie a tourniquet of heavy cord around the tire circumference and tighten with a tire iron.

Do not use a hammer to install the tire on the rim as damage may result to the beads which will prevent proper seating of the tire. When using tire irons, take small "bites" around the flanges to prevent injury to the beads.

After a tire is mounted on the rim, give it a few quick "shots" of air to seat the bead properly, then inflate the tire to 40 pounds pressure. Check to see that the bead positioning rib (outer ring of the tire) is visible evenly just above the rim flange all the way around the tire.



8062

Fig. 33—Bead Loosening Tool

Finally, deflate the tire to the recommended pressure.

d. Tire Repair.

The tubeless tire repair methods given here are general in nature, and it is advisable to follow the repair recommendations given by the manufacturer of the tire to be repaired.

(1) **PRESSURE GUN METHOD.** This method can be used for holes less than $\frac{1}{16}$ inch in diameter.

Make sure the area around the hole is completely dry, then deflate the tire to 5 pounds pressure. Remove all foreign matter from the hole with a rasp. Be careful not to enlarge the hole. Clean the area with solvent or gasoline.

Turn the handle of the pressure gun until sealing compound appears at the end of the nozzle. Wipe the excess compound from the nozzle so that only fresh

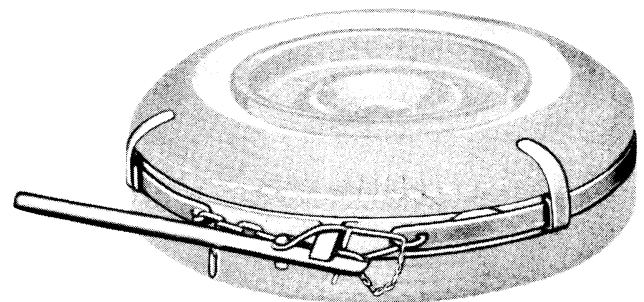

8061

Fig. 34—Tire Mounting Band



Fig. 35—Tire Repair Pressure Gun

compound will be used in the hole. Hold the nozzle of the gun against the hole, and turn the gun handle three or four half turns (fig. 35).

Remove the gun from the hole slowly and carefully so that the sealing compound will not pull away from the hole and stick to the nozzle.

Allow the tire to stand for at least 15 minutes, then inflate to the recommended pressure. Check the repair for leaks.

(2) COLD PATCH SELF-VULCANIZING METHOD. This method can be used for all holes up to $\frac{3}{16}$ inch in diameter.

Remove the tire from the rim. Remove all foreign matter from the hole with a rasp. Do not enlarge the

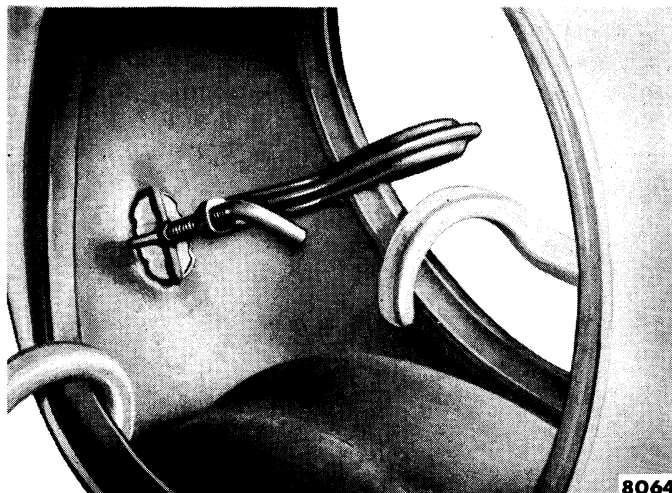

Fig. 36—Hot Patch Installation

hole. Clean the inside of the tire thoroughly around the hole with solvent or gasoline, then blow any vapors out of the tire with compressed air.

Fill the hole from the outside of the tire with sealing compound using the pressure gun (fig. 35), or from the inside with filler rubber. To insert the filler rubber, dip an awl needle in self-vulcanizing fluid and force the needle through the tire from the inside until the point extends beyond the tread. Cut a $\frac{1}{8}$ inch strip of filler rubber and place the rubber in the hole of the needle with the end of the rubber extending beyond the needle. Pull the needle through the tire with pliers, and the filler rubber will stay in the hole. Cut off any excess rubber inside the tire so that it is flush with the tire body.

Roughen the area around the hole with a hand buffer or a wire brush. Apply self-vulcanizing cement over the area and allow the cement to dry for at least five minutes. Remove the foil backing from a patch base, then place the patch over the hole. Roll down on the patch, especially along the edges, to make sure that it is adhering to the tire.

(3) HOT PATCH METHOD. This method can be used for all holes up to $\frac{3}{16}$ inch in diameter.

Remove the tire from the rim. Remove all foreign matter from the hole with a rasp. Do not enlarge the hole. Fill the hole from the outside of the tire with sealing compound using the pressure gun (fig. 35).

Clean the inside of the tire thoroughly around the hole with solvent or gasoline. Roughen the area with a hand buffer or a wire brush. Install a hot patch over the hole using a C-clamp to hold the patch in place (fig. 36).

Ignite the patch, then allow it to cool for at least 15 minutes before removing the clamp from the tire. Remove the metal cup from the patch, then clean all ashes and other foreign matter from the inside of the tire.

Mount the tire on the rim, then inflate the tire to the recommended pressure. Check the repair for leaks.

e. Tubeless Tire Valve Replacement.

If it becomes necessary to replace the valve in the wheel rim, the tire must be removed from the rim.

Remove the valve from the rim. Coat a new valve with a vegetable oil soap solution, then position the valve in the valve hole of the rim. Use a rubber hammer or a valve replacing tool to knock the valve into place until the valve is firmly seated against the inside of the rim. Be sure the valve is installed straight in the hole.

10. HUBS AND BEARINGS

a. Front Hubs, Bearings and Grease Retainers.

The front hubs are built integral with the front brake drums. The hubs are mounted on tapered roller wheel bearings installed at the inner and outer ends of each hub (fig. 37). The wheel bearings are adjusted and held in place by a castellated adjusting nut.

The front wheel bearings rotate in bearing cups which are pressed into the hub. Oil seals are installed at the inner end of each front hub to prevent the possibility of lubricant leaking into the brake drums.

(1) **ADJUSTMENT.** To check the wheel bearing adjustment, raise the front of the car, grasp the tire at the sides, then alternately push inward and pull outward on the tire. If any looseness is felt, adjust the front wheel bearings as follows:

Remove the hub cap, the front hub grease cap, and the cotter pin. Tighten the wheel bearing adjustment nut while rotating the wheel back and forth, until a slight drag is felt. This will assure the proper seating of the wheel bearing in the bearing cups. Back off the adjusting nut until the nearest slot in the nut is aligned with the cotter pin hole in the spindle (about $\frac{1}{6}$ to $\frac{1}{4}$ turns). Lock the adjusting nut in this position with a new cotter pin. When the wheel bearings are properly adjusted, the wheel will rotate freely with no perceptible end play.

NOTE: *If the wheel rotates roughly or noisily, the wheel bearings or cups are worn or dirty and should be cleaned or replaced.*

(2) **REPLACEMENT.** Remove the wheel and tire assembly. Remove the wheel bearing adjusting nut, the

flat washer, and the outer wheel bearing from the hub, then pull the hub and drum assembly off the spindle. Remove the grease retainer from the hub with a suitable puller, then lift the inner wheel bearing out of the hub.

Inspect the inner and outer wheel bearing cups for wear or damage. If the cups are worn or damaged, remove the cups with a drift. Always replace the bearings if the cups are replaced.

Clean the wheel bearings thoroughly, then inspect the bearings for wear or damage. Replace the bearings if necessary. In most cases, the grease retainer should be replaced. The same retainer should be reinstalled only if it is in good condition. New grease retainers should be soaked in light oil for one-half hour prior to installation.

If the bearing cups were removed, install them with the tools shown in fig. 38. Pack the wheel hub cavity to the inside diameter of the bearing cups with grease. Use a bearing packer to pack the inner wheel bearing with grease, then install the bearing in the hub.

Drive the grease retainer into the hub, until firmly seated, with the reverse end of the tool shown in fig. 38.

Place the hub and drum assembly on the spindle, carefully, so as not to damage the grease retainer. Pack the outer wheel bearing with grease.

Position the outer wheel bearing and flat washer on the spindle, then install the adjusting nut. Position the wheel and tire assembly on the hub, then install the wheel stud nuts. Tighten the wheel stud nuts to 65-70 foot-pounds torque. Adjust the wheel bearings, then install a new cotter pin. Install the front hub grease cap and the hub cap, then lower the car to the floor.

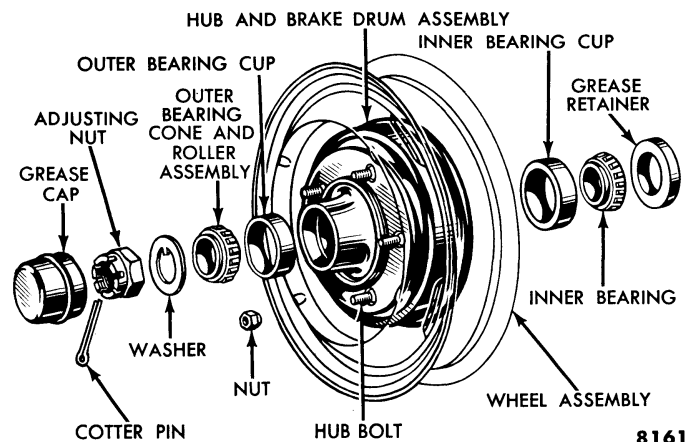

Fig. 37—Front Hub and Bearings

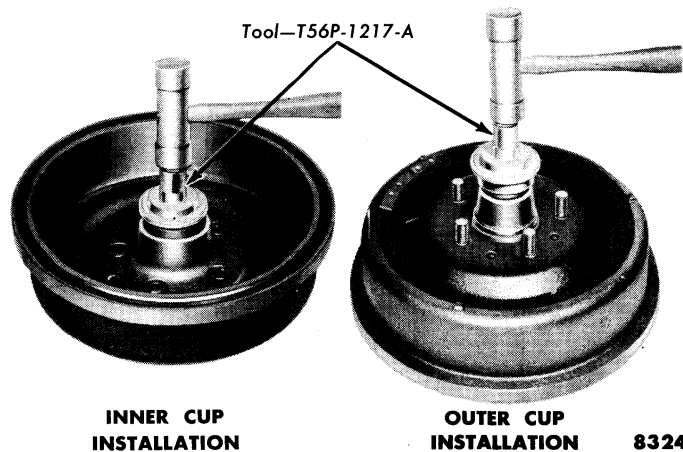

Fig. 38—Front Wheel Bearing Cup Installation

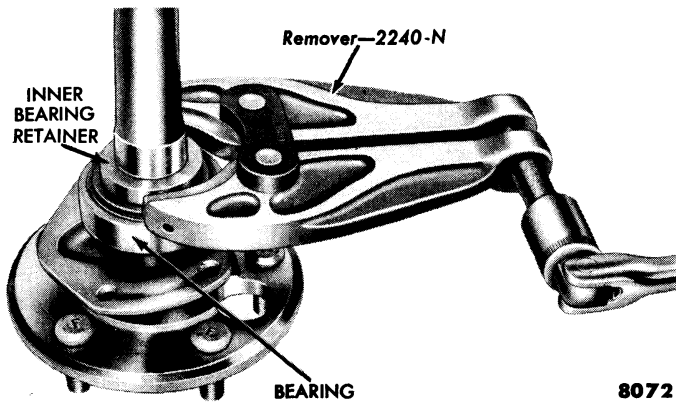

Fig. 39—Bearing Retainer Ring Removal

b. Rear Hubs, Bearings, and Oil Seals.

The passenger car, and the station wagon, Courier, and Thunderbird rear wheel bearings are single-row, prelubricated, sealed ball bearings which are pressed on the axle shafts. An axle shaft bearing retainer ring is pressed on the shaft, behind each bearing, to hold the bearing in position.

Oil seals are used at each end of the axle housing to prevent lubricant leakage into the brake drums. The oil seals are installed in the bore of the axle housing and wipe on the machined surface of each axle shaft.

(1) **ADJUSTMENT.** The rear wheel bearings do not require adjustment. However, the condition of the bearings should be checked each time the axle shafts are removed.

Grasp the bearing outer race and “rock” the bearing on the axle shaft, checking for looseness at the bearing oil seal. Inspect the bearing for lubricant leakage. If excessive looseness is evident or if lubricant appears on

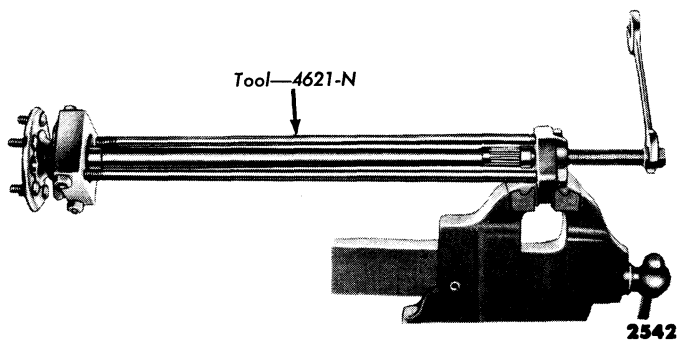

Fig. 40—Rear Wheel Bearing Removal

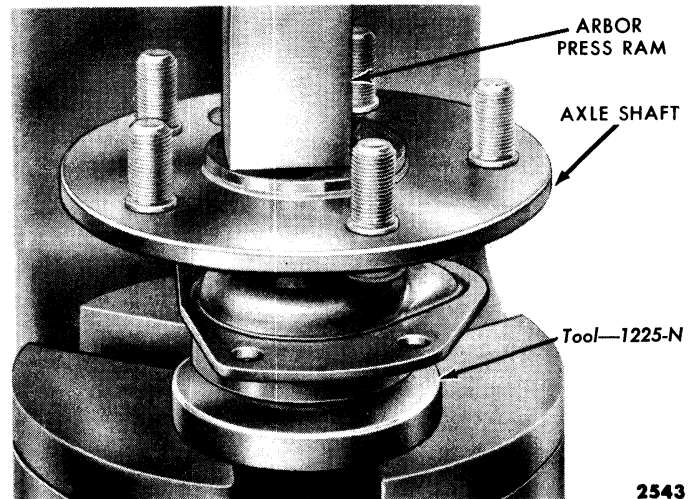

Fig. 41—Rear Wheel Bearing Installation

the bearing during the “rocking” process, replace the bearing.

(2) **REPLACEMENT.** Remove the axle shaft. Loosen the axle shaft bearing retainer ring with the tool shown in fig. 39. If this tool is not available, loosen the ring with a chisel, being careful not to damage the axle shaft during the operation. Remove the bearing retainer ring from the axle shaft, then remove the wheel bearing with a tool which will not damage the axle shaft as the tool shown in fig. 40.

NOTE: Remove bearings only when replacement is necessary since removal of the bearing makes it unfit for further use.

Remove the rear wheel bearing oil seal from the axle housing. Examine the seal for signs of wear or damage. Discard the seal unless it is in good condition. Before installing a new seal, soak the seal in light engine oil for at least one-half hour.

Examine the machined surface of the axle shaft, contacted by the lip of the seal and the axle housing bore for any irregularities which would impair sealing action. Remove all irregularities from the axle shaft and housing bore.

Position the oil seal in the housing bore. Press the new rear wheel bearing on the axle shaft, with the tool shown in fig. 41, until the bearing seats against the shoulder on the shaft. Press the bearing retainer ring on the shaft until firmly seated against the bearing. Install the axle shaft being careful not to damage the oil seal.

Part Two
CHASSIS

Chapter
IV

Power Steering

Section	Page
1 Trouble Shooting	183
2 Inspection and Maintenance	186
3 Power Steering System Operation	187
4 Pump and Fluid Reservoir Assembly	190
5 Control Valve Assembly	194
6 Power Cylinder Assembly	200
7 Steering Linkage	202

A linkage-type power steering system is available, as optional equipment, for all cars. The power steering system (fig. 1) consists of a hydraulic pump and fluid reservoir assembly, a control valve assembly, a power cylinder assembly, the connecting fluid lines, and the steering linkage to the front wheels.

The engine crankshaft pulley, the steering arm to idler arm rod, the idler arm and bushings, and the idler arm mounting bracket differ in design from those used on cars with conventional steering.

Automatic Transmission Fluid—Type A is used as the hydraulic fluid in the power steering system.

I. TROUBLE SHOOTING

a. Preliminary Inspections.

If the power steering system is to operate properly, the fluid in the pump reservoir must be maintained at the specified level, the system must be free of fluid leaks, and the pump belt tension must be correctly adjusted. Always check these items before performing the operational tests.

b. Operational Tests.

If trouble is still present in the power steering system after the preliminary inspections have been made, the tests given below will help locate the difficulty. Make sure the front wheels are properly aligned, the tires are in good condition and inflated to the specified pressure, and the operation of the shock absorbers is satisfactory before the tests are performed.

(1) **TURNING EFFORT.** Place the car on dry concrete, then set the parking brake. Start the engine and allow it to run at idle speed. Turn the steering wheel to the left and right several times to warm the fluid to its normal operating temperature.

Hook a spring tension scale to the rim of the steering wheel (fig. 2). Measure the pull required to turn the wheel to the left, then to the right. If the pull on the steering wheel does not exceed 12 pounds, and is about equal in both directions, the power steering fluid pressure system is operating properly. If the pull is more than 12 pounds, refer to the list of possible causes for the excessive turning effort under "c, Diagnosis."

(2) **FLUID PRESSURE.** A fluid pressure test will determine whether the pump or some other unit in the power steering system is causing a malfunction of the system. The test is performed as follows:

Disconnect the pump to control valve pressure line hose from the pump outlet hose adapter. Connect the pressure testing tool inlet hose to the pump outlet hose adapter (fig. 3). Connect the other testing tool hose to the pump to control valve pressure line hose. The tool is correctly installed when the pressure gauge is between the pump and the shut-off valve on the tool.

Open the shut-off valve on the testing tool, then run the engine at idle speed for about two minutes to warm the fluid.

NOTE: *The normal operational pump noise may become louder when the pressure testing tool is installed. This noise may be ignored if the pump operates quietly with the testing tool removed.*

Turn the front wheels to the extreme right or left (against the stops), and note the pressure on the gauge. The pressure should be between 700 and 900 p.s.i.

CAUTION: *Do not hold the wheels against the stops for longer than 30 seconds at a time as this causes the fluid to heat up.*

If the pressure is less than 700 p.s.i., turn the wheels off the stops. Slowly close the gauge shut-off valve while observing the gauge for an increase in the pressure reading.

CAUTION: *Do not leave the valve closed for more than 15 seconds.*

If the pressure increases to 700-900 p.s.i., with the shut-off valve fully closed, the pump is operating satisfactorily; and the trouble is in the control valve, hose connections, or power cylinder.

If the pressure does not increase with the shut-off

valve closed, the pump is not operating properly and should be overhauled.

If the pressure increases with the valve closed, but does not reach 700 p.s.i., the pump, control valve, and power cylinder should be overhauled.

Shut off the engine, remove the testing tool, then connect the pump to control valve hose to the pump outlet fitting.

c. Diagnosis.

Power steering trouble symptoms are listed below in the most probable order of occurrence. The possible causes for each trouble are given along with the recommended corrections.

NOTE: *The symptoms, causes, and corrections presented here apply to only the power steering system units. However, any maladjustments or defects in the steering gear assembly or in the steering linkage should also be considered when diagnosing the trouble.*

(1) **BINDING OR POOR RECOVERY.** If a binding or sticking condition is noticed when the steering wheel is turned, or if the car has poor recovery action, check

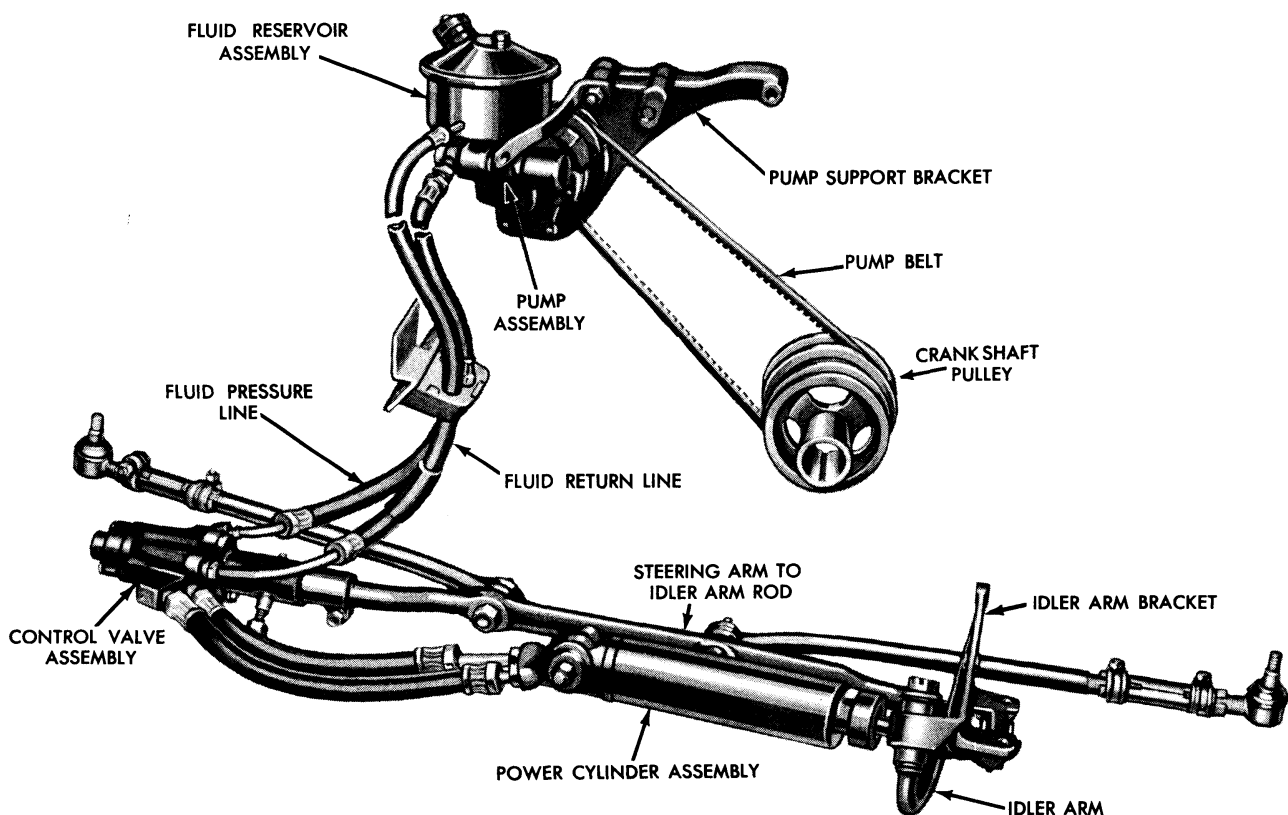

Fig. 1—Power Steering System

the following items in the order given:

Check the installation of the sector shaft arm ball stud in the control valve sleeve. If the ball stud is rubbing against the side of the valve sleeve T-slot, the roll pin may be missing. If so, position the control valve on the steering arm to idler arm rod so that the ball stud is centered in the sleeve; then install a new roll pin.

If the car has poor recovery action only, check the condition of the idler arm bushings. If the bushing shows signs of failure, replace the bushings. Check the steering gear adjustment, and adjust the worm bearing preload to $\frac{1}{2}$ pound and the mesh adjustment to one pound.

Check the operation of the control valve spool in the control valve housing. If the valve spool is binding in the housing, check the valve spool adjustment. If the adjustment is correct and binding still occurs, overhaul or replace the control valve assembly.

Check for interference between the sector shaft arm and the dust shield at the ball stud connection. If interference is evident, replace the dust shield and/or the ball stud.

Check the control valve spool stop screw adjustment. If the stop screw is drawn up too tightly, the ball stud will bind in the ball stud seats. Adjust the control valve spool stop screw as required.

Check the control valve sleeve and the socket tube for damage. Replace parts that show signs of damage, then adjust the control valve spool stop screw.

(2) **EXCESSIVE FREE PLAY.** If excessive free play or lost motion is noticed when steering, check the following items in the order given:

Check the steering gear mesh adjustment.

Check for excessive clearance between the steering arm ball stud and the ball stud seats. If the ball stud is loose in the seats, adjust the control valve spool stop screw.

Check the control valve centering spring adjustment. If the spring adjusting nut is loose, tighten the nut until snug; then back off the nut not more than $\frac{1}{4}$ turn.

(3) **HARD STEERING.** Do not confuse hard steering with binding. Hard steering is experienced when the effort required to turn the steering wheel is greater than normal for the entire travel of the front wheels. Binding is usually experienced for only a portion of the front wheel travel.

If hard steering is experienced, perform the following checks in the order given:

Perform a fluid pressure test. If the pressure test indicates that the pump output is low, check the pump belt tension. If the belt tension is incorrect, adjust the belt. Recheck the pump output. If the output is still low, the pump is defective and should be overhauled or replaced.

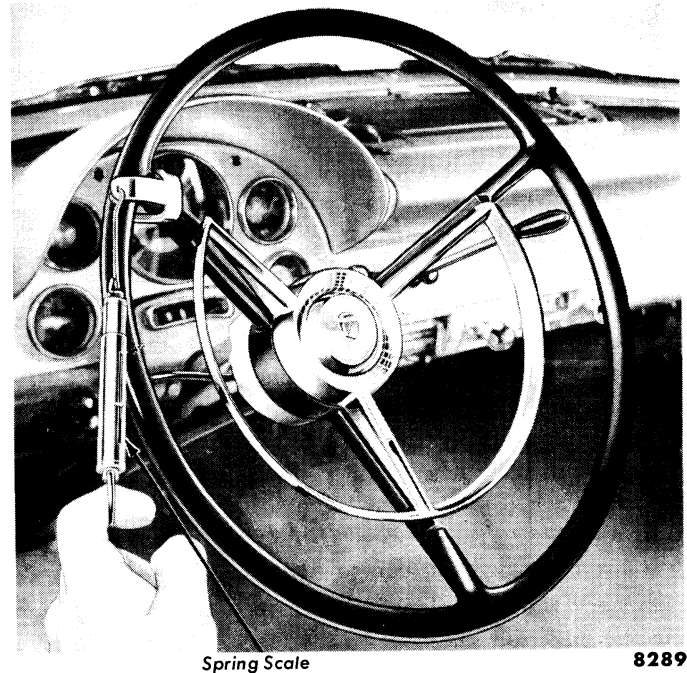

Spring Scale

8289

Fig. 2—Checking Turning Effort

If the pressure test indicates that the trouble is in the control valve or in the power cylinder, perform the following checks in the order given:

Disassemble the control valve assembly. Inspect the bore of the control valve housing and valve spool lands for grooves or scratches. If deep grooves or scratches are present, the control valve will leak internally and hard steering will result. Replacement of the control valve assembly will correct this condition. If the check valve does not operate freely, replace the check valve assembly.

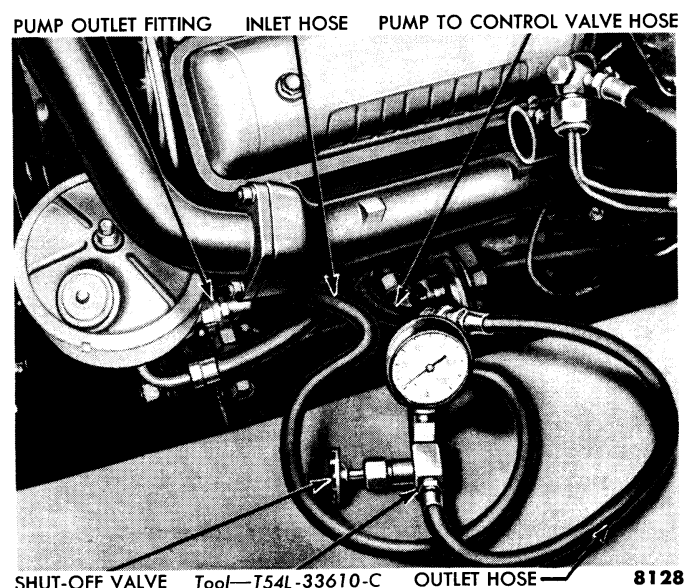

SHUT-OFF VALVE Tool—T54L-33610-C OUTLET HOSE 8128

Fig. 3—Checking Fluid Pressure

If the control valve is in good condition, the trouble is probably caused by excessive internal leakage in the power cylinder. A leaking power cylinder assembly should be replaced.

If the pressure test indicates that the pressures throughout the system are within specifications, check the following items in the order given:

Check the control valve spool centering spring adjustment. Adjust if required.

Check the control valve spool for freedom of movement. If the valve spool does not move freely, check for, and eliminate, interference between the socket tube and the control valve sleeve. If the valve spool is sticking in the housing, remove the spool; then check the spool lands for burrs. Small burrs may be removed with crocus cloth provided the edges of the valve lands are not rounded in the process. If the valve spool cannot be repaired, replace the control valve assembly.

Check the control valve ball stud for free movement in the ball stud seats. If the stud is binding in the seats, adjust the control valve spool stop screw.

(4) **NOISE.** Check the pump belt tension. If the belt is too tight, pump noise may result. If the belt is too loose, it may squeal. Adjust the pump belt to specifications.

If the noise seems to be in the pump, check the pump to control valve assembly hose. Noise may result if the specified hose is not used. If the specified hose is installed and the noise still exists, the pump may be defective. Disassemble the pump and make the necessary repairs.

(5) **STEERING CHATTER.** Check for looseness at the power cylinder piston rod insulators. If looseness exists at this point, inspect the insulators for wear and check the torque of the mounting nut and locknut. Replace worn insulators. Tighten the nuts to the specified torque.

A loose pump belt can cause chatter against the wheel stops during an extremely sharp turn. Check the tension of the pump belt. If the belt is loose, adjust the belt tension to specifications.

Check for looseness in the power cylinder to steering arm to idler arm rod connection. Looseness at this point may be due to worn mounting bushings or improper mounting nut torque. Replace the bushings if worn.

Tighten the nut to the specified torque.

Check the idler arm bushings for wear or failure. Replace worn or failed bushings.

(6) **RATTLES.** A rattle is a noise that is heard only when the front wheels are subjected to an impact or are passing over irregularities in the road. To locate the cause of a rattle, check the following:

Check the control valve spool centering spring adjustment. If the adjustment is loose, tighten the nut until snug; then back off the nut not more than $\frac{1}{4}$ turn.

Check for looseness between the control valve ball stud and the ball stud seats. If the stud is loose in the seats, adjust the control valve spool stop screw following the recommended procedure.

Check for interference between the spindle connecting rod and the lubrication fitting in the control valve.

(7) **LOSS OF POWER ASSIST.** If the power steering system is not providing a power assist to the front wheels, check the following items in the order given:

Check for a loose or broken pump belt. If the belt is loose, adjust it to specifications. Replace the belt if it is broken or worn.

Check the entire system for damaged or broken hoses, and replace them as required.

Perform a pressure test to determine whether the difficulty is in the pump, the control valve, or the power cylinder.

If the pressure test indicates that the pump is at fault, remove and overhaul the pump.

If the pressure test indicates that the control valve or power cylinder is at fault, check as follows:

Disconnect the power cylinder piston rod from the idler arm bracket. Operate the power cylinder piston by hand to check for resistance to movement. If the piston moves easily with little or no resistance, the internal parts of the power cylinder are broken or damaged to the extent that fluid is bypassing the piston. Replace the power cylinder assembly.

Extreme maladjustment of the control valve spool centering spring can also cause a loss of power assist. Check the adjustment, then readjust if necessary. Replace all defective parts.

Check the operation of the control valve check valve. If the check valve does not operate freely, replace the check valve assembly.

2. INSPECTION AND MAINTENANCE

a. Inspection.

Whenever the power steering system is inspected, the procedures given here for checking fluid level and pump belt tension should be followed.

(1) **FLUID LEVEL.** Start the engine, turn the steering wheel all the way to the left and right several times, then shut off the engine.

Remove the fluid reservoir filler cap, and check the fluid level. If the level is below the full mark on the

dipstick, add enough Automatic Transmission Fluid—Type A to raise the level to the full mark. Do not overfill the reservoir. Install the filler cap on the fluid reservoir when this inspection has been completed.

Inform the car owner that this fluid level check should be made regularly after each 1000 miles of operation.

(2) **PUMP BELT TENSION.** Install a torque wrench on the pump pulley bolt (fig. 4). Check the torque required to slip the pulley against the belt friction. If the torque is not within 14-16 foot-pounds, an adjustment should be made.

Place a heavy-duty 2½-inch “C” clamp as shown in fig. 4. Loosen the four pump attaching bolts until the pump body may be moved by tightening the “C” clamp. Tighten the clamp until a torque of 14-16 foot-pounds is required to slide the pump pulley.

NOTE: *The final torque specification should be as close to the upper limit as possible.*

Tighten the pump attaching bolts, remove the “C” clamp, and make a final check of the pulley sliding torque.

b. Maintenance.

Very little maintenance is required to keep the power steering system operating properly. The oil level should be checked, each 1000 miles, following the procedure given under the heading, “(1) Fluid Level.”

The oil should be changed only when it is necessary to drain the power steering system for repairs.

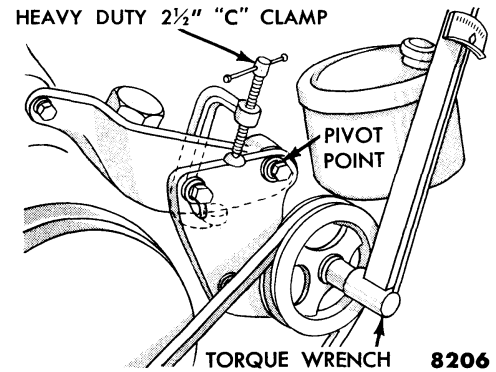

Fig. 4—Pump Belt Tension Adjustment

The oil filter element assembly should be replaced at 25,000 mile intervals, using the following procedure:

Remove the oil reservoir filler cap. Draw as much oil as possible out of the oil reservoir with a suction gun. Loosen and remove the reservoir cover retaining bolt, then remove the cover and gasket from the reservoir body. Lift the filter element out of the reservoir.

Place a new filter element in the oil reservoir. Lay the retaining spring seat on top of the element, then install the retaining spring.

Place a new seal on the reservoir cover retaining bolt. Install a new cover gasket in the reservoir cover, then position the cover on the reservoir body. Tighten the cover retaining bolt.

Fill the reservoir, to the proper level, with Automatic Transmission Fluid—Type A. Install the oil reservoir filler cap.

3. POWER STEERING SYSTEM OPERATION

The pump supplies fluid, under pressure, to the control valve. When the steering wheel is turned, the control valve directs this fluid pressure to the right or left side of the power cylinder piston, depending upon the direction of the turn. The pressure against the piston forces the piston rod to the right or left, and moves the steering arm to idler arm rod in the same direction to turn the front wheels.

a. Straight-Ahead Driving.

When the front wheels and the steering wheel are in the straight-ahead position, the control valve spool is held in the center (neutral) position, by the centering spring (fig. 5). In this position, fluid from the pump flows by the valve spool lands and returns to the reservoir through the port in the control valve housing.

Only a small amount of fluid pressure resistance exists in the system under this condition. The pump delivers

just enough fluid pressure to overcome the resistance and maintain a balanced condition on both sides of the power cylinder piston.

b. Left Turn.

When the steering wheel is first turned to the left, the sector shaft arm moves the control valve spool to the right. The preloaded centering spring resists this movement until about four pounds of force is exerted on the steering wheel rim. Consequently, the initial force on the wheel is transmitted directly to the steering arm to idler arm rod.

When the turning force on the steering wheel rim exceeds this amount, the valve spool moves to the right, against the centering spring, as shown in fig. 6. When the valve spool is in this position, the fluid passage leading to the left-hand end (piston end) of the power cylinder is closed to pump pressure, but is open to the reservoir.

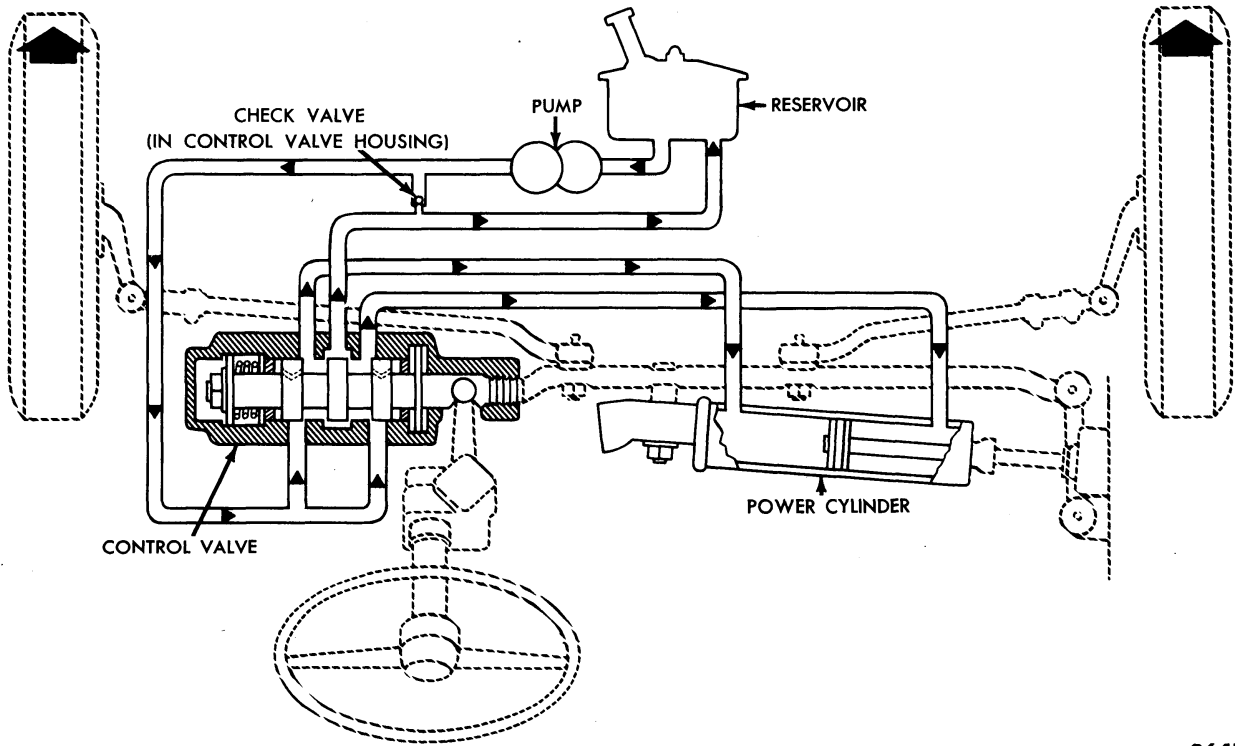

Fig. 5—Fluid Flow—Straight-Ahead Driving

2647

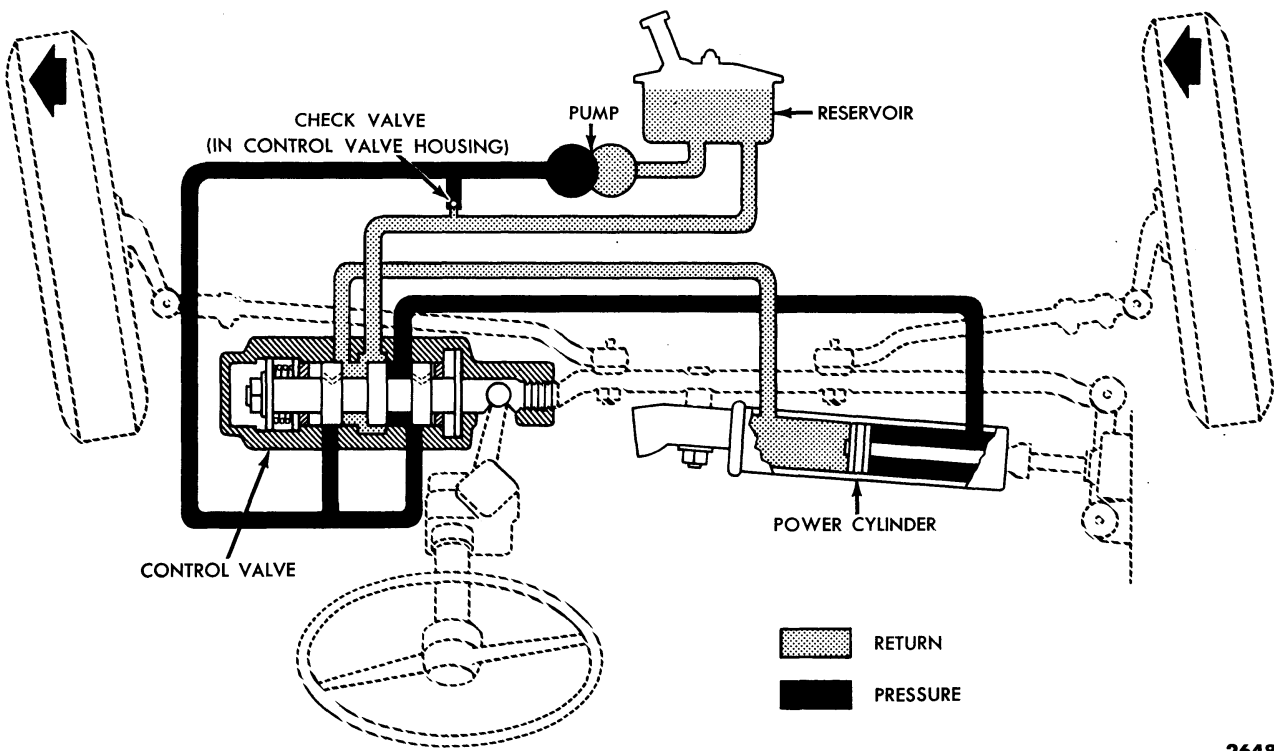

Fig. 6—Fluid Flow—Left Turn

2648

The passage leading to the right-hand end (piston rod end) of the cylinder is open to pump pressure.

As the fluid from the pump flows into the power cylinder, the pressure increases until it is sufficient to force the cylinder and the steering arm to idler arm rod to the right, thus providing the power assist for the left-turn. The fluid displaced from the left-hand end of the power cylinder flows back through the control valve to the fluid reservoir.

When the steering wheel is stopped at any position, or when the force on the wheel is reduced below the control valve centering force, the control valve spool returns to the center position and stops the power assist.

c. Right Turn.

When making a right turn, the sector shaft arm moves the control valve spool to the left in the same manner as when making a left turn. The movement of the valve spool opens the fluid pressure supply passage in the valve housing leading to the left-hand end of the power cylinder (fig. 7). As the pressure in the power cylinder increases, the cylinder and the steering arm to idler arm rod move to the left, thus providing the power assist for the right-turn. The fluid displaced from the right-hand end of the power cylinder flows back through the control valve to the fluid reservoir.

d. Reaction to Road Shock.

When road shock is translated into movement of the steering arm to idler arm rod, the control valve housing moves relative to the control valve spool, and a counteracting force is supplied by the power cylinder which largely absorbs the shock.

The idler arm bushings and the rubber bushings, used on the power cylinder and the piston rod, also absorb a certain amount of road shock.

e. Wheel Recovery After a Turn.

When the car wheels turn, a tension is imposed on the rubber portion of the idler arm bushings. When the steering wheel is released after a turn, the tension in the bushings and the natural effect of "king pin inclination" return the wheels to the straight-ahead position.

As the control valve spool is in the center position when the force on the steering wheel is released, fluid on one side of the power cylinder piston is free to return to the fluid reservoir and to the other side of the piston. Thus, the power cylinder offers no noticeable resistance to wheel recovery action.

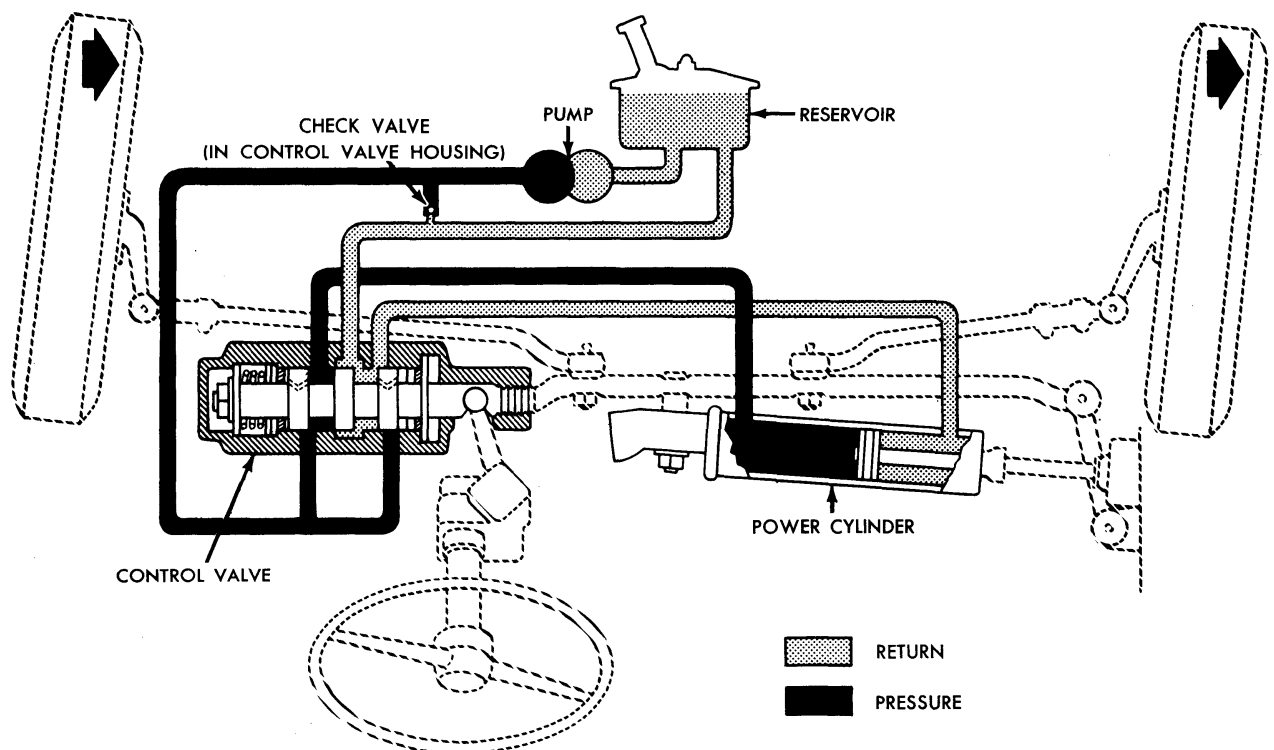

Fig. 7—Fluid Flow—Right Turn

f. Operation Without Pressure Supply.

If the pump fails to deliver fluid pressure for any reason, the car may be steered manually. Steering effort is not appreciably increased over that required for the conventional steering system.

When the steering wheel is turned, the movement of the sector shaft arm transmits the manually applied

force to the control valve spool. The spool moves approximately 0.060 inch before it contacts its stop, then the full manual effort is transmitted to the steering linkage. With the valve spool off the center position, fluid is displaced from one end of the power cylinder to the control valve. This creates a suction in the opposite end of the power cylinder which opens the ball check valve in the control valve housing. The fluid then flows to the suction end of the power cylinder.

4. PUMP AND FLUID RESERVOIR ASSEMBLY

a. Construction and Operation.

Certain design differences exist between the pump and fluid reservoir assemblies used on the 6-cylinder and 8-cylinder engines. However, the operation of both assemblies is basically the same.

(1) **PUMP.** The rotor-type hydraulic pump is bolted to the pump adjusting bracket. On the 6-cylinder engine, the adjusting bracket is bolted to the generator mounting bracket. The adjusting bracket on the 8-cylinder engine is mounted on the pump support which is bolted to the front of the engine. Another bracket is fastened to the pump support and to the left-hand exhaust manifold.

The pump is driven by a single V-belt from the crankshaft pulley or damper. A bolt slot in the pump adjusting bracket permits adjusting the belt tension.

Two pump rotors are installed in the pump housing (fig. 8). The drive rotor is keyed to the rotor shaft. The pulley end of the shaft is supported by a sealed ball bearing assembly which is installed in the pump housing. A lip-loaded seal behind the bearing assembly prevents fluid leakage. The center and the inner end of the

shaft are supported by bronze bushings pressed into the pump housing and housing cover.

A piston type, spring-loaded flow-control valve is installed in the pump housing cover. A cylindrical, spring-loaded pressure-relief valve is installed in the flow-control valve. The flow-control valve and valve spring are retained in the pump housing cover by the fluid outlet hose adapter. A circular, neoprene seal on the adapter prevents fluid leakage. An orifice plate, with a small metering hole at its center, is installed between the flow-control valve spring and the pressure-relief valve snap ring.

Two dowels in the pump housing cover insure correct positioning of the cover on the housing.

At idle or low engine speeds, the pump is operating at minimum output, which is high enough to provide the necessary power assist when the car is being maneuvered at low speeds or parked.

The flow-control valve limits the maximum output of the pump to about 2.0 gallons per minute, regardless of engine speed. The flow-control valve operates in the following manner:

Fluid, from the pressure side of the pump rotors, flows to the chamber containing the flow-control valve, then to the closed end of the valve. The fluid flows to the inside of the valve through the pressure-relief valve and the metering orifice, and out to the control valve.

When the pump speed is increased, due to an increase in engine speed, the pump rotors tend to deliver more fluid than is needed to steer the car. This increased output, in an effort to pass through the two metering holes in the valve walls, creates a difference in pressure between the outside and the inside of the flow-control valve.

When the pressure on the closed end of the flow-control valve exceeds the pressure inside the valve, the valve moves to the left and compresses the flow-control valve spring. This action uncovers a relief groove in the flow-control valve body which permits excess fluid to flow, through a passage in the pump housing, back to the suction side of the pump.

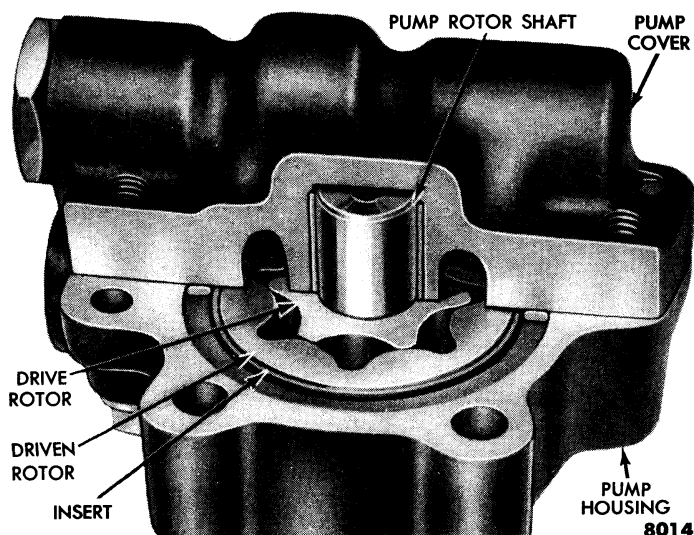

Fig. 8—Cutaway View of Pump

The amount of pressure produced depends upon the pressure required to operate the power cylinder. When driving straight ahead, the power cylinder is not operating, and the pump produces just enough pressure to maintain a pressure balance (about 30-50 p.s.i.) on both sides of the power cylinder piston.

When making turns, under various road conditions, higher pressures may be required. However, the maximum pressure that the pump will deliver to the control valve is limited by the pressure-relief valve.

The pressure-relief valve spring is designed so that a pressure of about 700-900 p.s.i. is required in the system to overcome the force of the spring. As the area of the left face of the valve is greater than the area of the right face, the valve will move to the right when the maximum pressure is reached. This movement uncovers ports in the flow-control valve, which permit the fluid to return to the suction side of the pump, and prevents further pressure build-up.

The pressure-relief valve action takes place regardless of the position of the flow-control valve in its bore, as the action of the flow-control valve controls only the volume of fluid delivered by the pump rotors.

(2) **FLUID RESERVOIR.** On all cars, the fluid reservoir is mounted on the power steering pump housing.

The reservoir used on the 6- and 8-cylinder engine (fig. 9) is held in place by the reservoir retaining bolt, which threads into the pump body, and by the orifice reinforcement plate.

The filter element seats on the filter support and is held in place by a spring installed between the element and the reservoir cover assembly.

An indicator (dipstick), for checking the fluid level in the reservoir (fig. 9), is attached to a removable filler cap installed on the reservoir cover.

A gasket is used between the reservoir body and the cover. "O" ring seals are installed between the reservoir and pump body at the pump inlet tube and the reservoir retaining bolt.

The reservoir retaining bolt also holds the filter element support in position. A pipe, near the bottom of the reservoir, connects with the hose that returns the fluid from the control valve to the reservoir.

b. Overhaul.

If the pressure test or diagnosis indicates that a complete overhaul of the pump is necessary, the pump and reservoir assembly should be removed, completely disassembled, and repaired.

(1) **REMOVAL.** Remove the fluid reservoir filler cap, then remove as much fluid as possible from the reservoir with a suction gun.

Disconnect the pump to control valve hose assem-

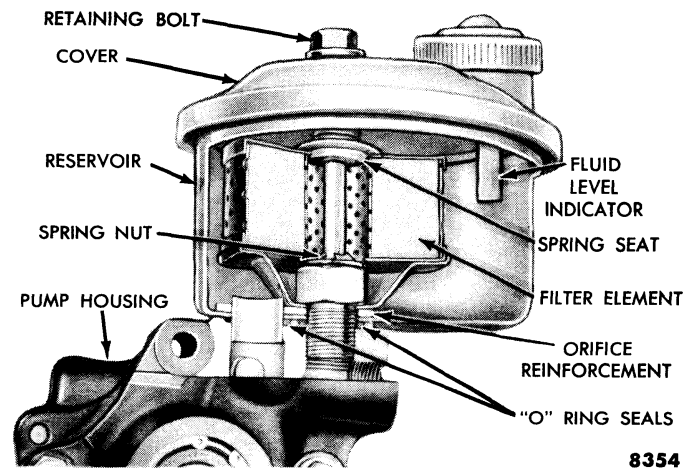

Fig. 9—Fluid Reservoir Construction

blies at the pump pressure and reservoir fittings. Fasten the ends of the hoses in a raised position to prevent fluid drainage.

Loosen the pump belt adjusting bolt and the adjusting bracket to pump support bolt, then remove the pump belt. Remove the belt adjusting bolt and washer. Remove the adjusting bracket to support bolt and washer, then remove the pump and the adjusting bracket, as an assembly, from the car.

(2) **DISASSEMBLY.** Drain as much of the remaining fluid as possible from the pump and reservoir. Do not allow dirt to enter the pressure or reservoir return port.

Clamp the pump adjusting bracket in a vise. Remove the reservoir cover retaining bolt, cover, gasket, spring, and spring seat as an assembly from the reservoir. Remove the filter element.

Remove the filter element support bolt. Remove the filter element support, then remove the reservoir body from the pump.

Remove the pulley and pulley key from the pump rotor shaft.

Separate the pump housing cover and the housing. Tap the parts gently with a soft hammer if necessary.

Remove the pump rotors and the pin from the pump rotor shaft. If the drive rotor is tight on the shaft, press the shaft out of the rotor shaft bearing assembly, then press the shaft out of the rotor.

CAUTION: Handle the rotors, pump housing, and cover carefully as nicks, burrs, cracks, or scratches may make them unfit for further service.

Clamp the pump housing in a vise, then remove the rotor shaft bearing retainer with snap ring pliers (fig. 10).

Press or tap rotor shaft and bearing assembly from the pump housing, being careful not to damage the shaft or the bearing.

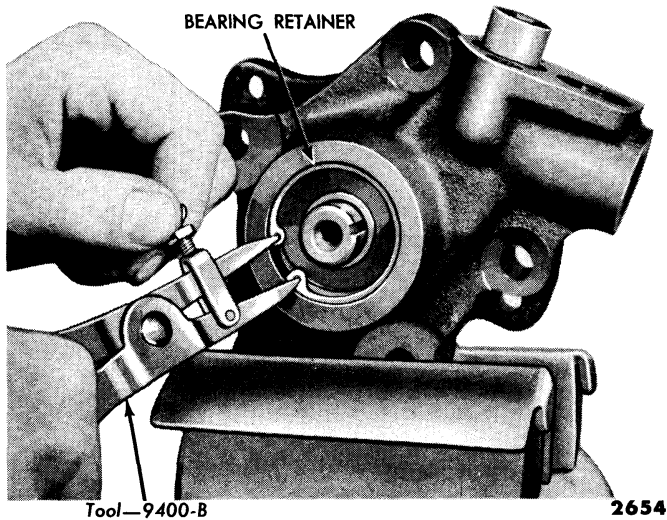

Fig. 10—Bearing Retainer Removal

Inspect the rotor shaft bearing for smooth operation or for wear and other damage. If replacement is necessary, press the bearing off the shaft using an arbor press and an adapter (fig. 11).

NOTE: *Be sure that the adapter presses against the bearing inner race.*

Inspect the rotor shaft seal for wear or damage. If the seal needs to be replaced, remove the seal from the pump housing with a punch. Do not remove the seal if it is in good condition as removal makes the seal unfit for further service.

Lift the flow director "O" ring out of the bore in the pump housing.

Clamp the pump housing cover in a vise equipped with brass jaws, then remove the pump outlet hose

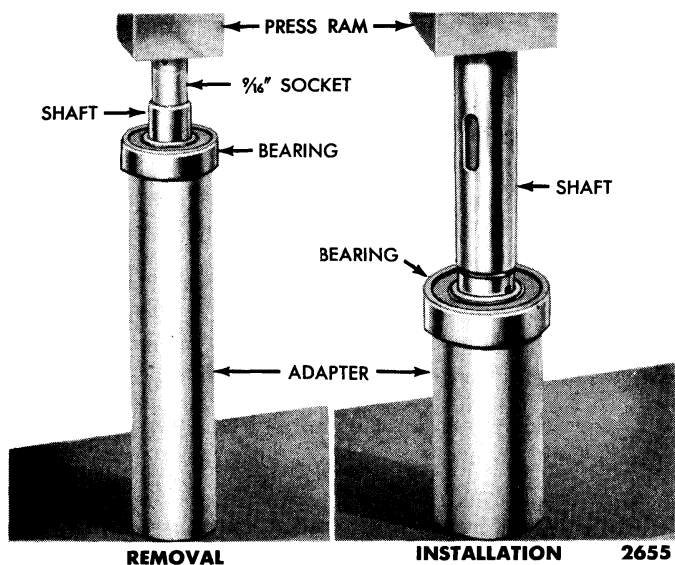

Fig. 11—Rotor Shaft Bearing Replacement

adapter from the cover. Slide the "O" ring off the adapter. Remove the flow-control valve spring and the orifice plate from the pump housing cover.

Carefully pull the flow-control valve out of the pump housing cover with a wire as shown in fig. 12.

Remove the retainer (snap ring) that secures the pressure-relief valve and spring in the flow-control valve, with the tool shown in fig. 10. Remove the pressure-relief valve and spring from the bore of the flow-control valve.

CAUTION: *Handle the pressure-relief and flow-control valves carefully to avoid damage to the parts.*

(3) **CLEANING, INSPECTION, AND REPAIR.** Wash all parts, except the rotor shaft bearing assembly, in a suitable solvent. Wipe the parts dry with a lint-free cloth.

Clean the bearing assembly with a dry cloth. Do not soak the bearing in solvent as the sealed-in lubricant may become diluted by the solvent.

Inspect the pump housing and cover for signs of wear caused by the rotation of the rotors. Check the bushings in the housing and cover for wear or scores. If the pump housing, or the bushing in the housing, is worn or damaged, replace the cover and bushing assembly.

Inspect both rotors for wear, cracks, scores, or other damage. If either rotor is damaged or worn, replace the pump housing and rotor assembly. If both rotors appear to be in good condition, proceed as follows:

Press the rotor shaft bearing assembly on the shaft, as shown in fig. 11, until the bearing is seated against the shoulder on the shaft. Tap the shaft and bearing assembly into the pump housing until the bearing is seated in the housing.

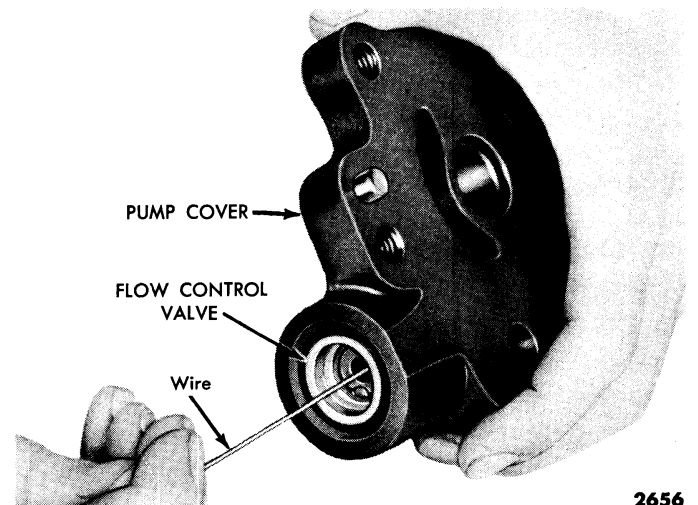

Fig. 12—Flow-Control Valve Removal

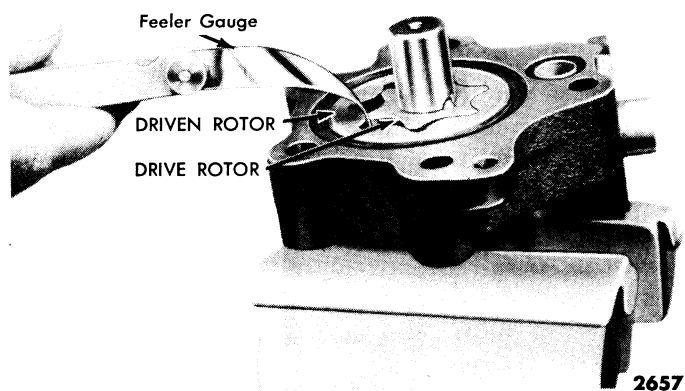

Fig. 13—Checking Clearances Between Rotors

NOTE: When seating the bearing in the pump housing, apply pressure to the outer race of the bearing.

Install the drive rotor and pin on the rotor shaft, then install the driven rotor. Check the clearances between the rotors, at all points, with a feeler gauge as shown in fig. 13. If the clearances exceed 0.008 inch, replace the pump housing and rotor assembly.

Check the clearance between the top of the rotors and the surface of the pump housing with a feeler gauge and a straight edge (fig. 14). If the clearance exceeds 0.0025 inch, replace the pump housing and rotor assembly.

Check the clearance between the driven rotor and the insert in the pump housing as shown in fig. 15. If the clearance exceeds 0.008 inch, replace the pump housing and rotor assembly. If all the clearances are within specifications, remove the rotors, pin, shaft, and bearing from the pump housing.

Make sure the pressure-relief valve and the bore of the flow-control valve are thoroughly dry. Insert the pressure-relief valve in the bore of the flow-control valve, then shake the valve. If the pressure-relief valve does not move freely in the bore, remove the valve and check for burrs. Remove all burrs with crocus cloth. Check the flow-control valve for free movement in the bore of the pump housing cover. If necessary, remove all burrs with crocus cloth.

Check the tension of the flow-control valve spring with an engine valve spring checking tool. The spring should exert a pressure of 12½-15½ pounds when compressed to a height of 1¹³/₆₄ inches. If the tension is not within specifications, replace the spring.

Check the tension of the pressure-relief valve spring. The spring should exert a pressure of 29-32 pounds when compressed to a height of 1³/₁₆ inches. If the tension is not within specifications, replace the spring.

(4) **ASSEMBLY.** Coat all parts with Automatic Transmission Fluid—Type A before assembly.

If the rotor shaft seal was removed, install a new seal as follows:

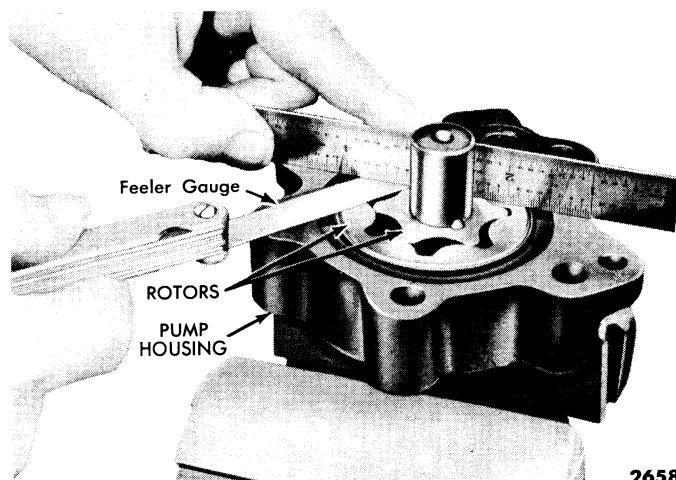

Fig. 14—Checking Rotor to Housing Clearance

Coat the lip of the new seal with Lubriplate, or an equivalent lubricant. Position the seal in the bore of the pump housing with the lip of the seal toward the pump rotors. Drive the seal into the pump housing, until firmly seated, with the tools shown in fig. 16.

Tap the rotor shaft and bearing assembly into the pump housing until the bearing is seated in the housing. Install the bearing retainer with the tool shown in fig. 10.

Install the drive rotor and pin on the rotor shaft, then install the driven rotor.

Position the pressure-relief valve spring and the pressure-relief valve in the bore of the flow-control valve. Install the pressure-relief valve retainer with the tool shown in fig. 10.

Place the flow-control valve in the bore of the pump housing cover, being careful not to damage the valve

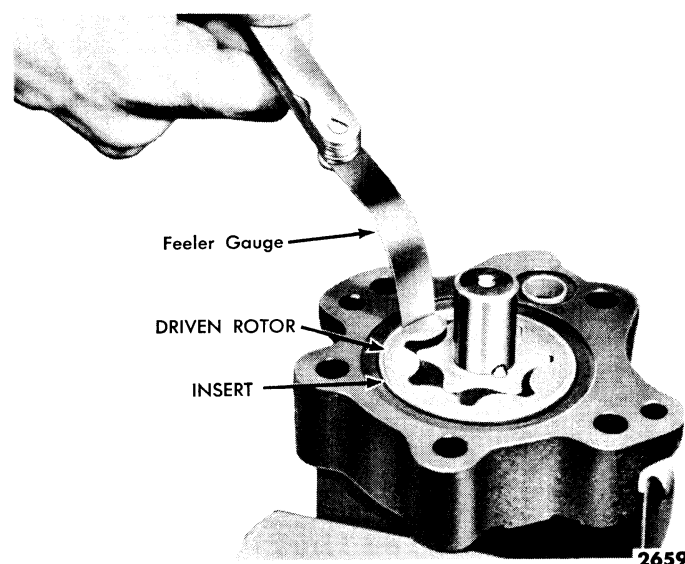

Fig. 15—Checking Rotor to Insert Clearance

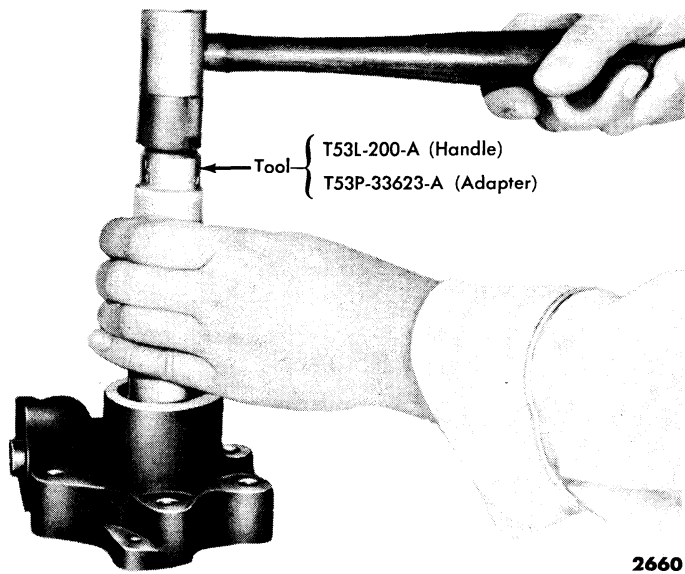

Fig. 16—Rotor Shaft Seal Installation

lands or the bore of the cover. Place the orifice plate and the flow-control valve spring on the valve.

Install a new “O” ring seal on the pump outlet hose adapter, then install the adapter in the pump housing cover. Tighten the adapter to 30-35 foot-pounds torque.

Position a new pump housing cover gasket in the groove in the pump housing. Install a new “O” ring seal around the flow director in the pump housing.

Position the pump housing cover on the housing, then install the two housing to cover attaching bolts and lock washers. Clamp the pump adjusting bracket in a vise, then place the pump housing on the bracket. Install the three bracket to pump housing bolts and lock washers, then tighten all five bolts evenly to 30-35 foot-pounds torque.

Position the pump pulley key in the slot in the rotor shaft, and tap the pump pulley on the shaft. Install the flat washer and the screw and lock washer assembly that secure the pulley to the shaft. Tighten the bolt to 18-20 foot-pounds torque.

IMPORTANT: *Check the rotor shaft for free operation. If the shaft does not rotate freely disassemble the pump and determine the cause of the binding.*

Position new “O” rings in the two grooves in the top of the pump body.

Place the fluid reservoir body on the pump housing, then position the reinforcement in the reservoir body (8-

cylinder). Install the filter support and reservoir retaining bolt, and tighten securely.

Position the filter element on the filter support. Lay the filter element retaining spring seat on the element, then place the retaining spring on the spring seat.

Install a new reservoir cover gasket in the cover, then position the cover, spring, spring seat, and bolt on the reservoir. Install a new seal on the reservoir cover retaining bolt if needed. Tighten the bolt securely. Check the cover to make sure that it is installed flush with the top of the reservoir.

(5) **INSTALLATION.** Install a flat washer on the belt adjusting bolt. Insert the bolt in the slot of the pump adjusting bracket. Position the pump and adjusting bracket assembly on the pump support. Install the adjusting bracket to pump support bolt and flat washer. Install a lock washer on the belt adjusting bolt, then install the nut on the bolt and tighten it finger tight.

Position the pump belt on the crankshaft pulley and pump pulley. Move the pump assembly to tighten the belt, then check the belt tension. When the correct belt tension is obtained, tighten the belt adjusting bolt to 30-35 foot-pounds torque. Tighten the adjusting bracket to pump support bolt to 20-25 foot-pounds torque.

Check the alignment of the crankshaft pulley with the pump pulley. If the pulleys are not aligned, check the assembly for the correct installation of the pump. It may be necessary to install spacers to align the pulleys.

Connect the pump to control valve hose to the pump pressure port and return line hose to the reservoir. Tighten the adapters to 30-35 foot-pounds torque.

Fill the fluid reservoir to the specified level with Automatic Transmission Fluid—Type A, then bleed the system as follows:

Operate the engine at idle speed for about two minutes to warm the fluid. Turn the steering wheel all the way to the right and left several times. Check the fluid level, then check all hose connections for leaks.

Increase the engine speed to about 1000 r.p.m., then turn the steering wheel to the right and left several times.

Stop the engine, and check the pump, reservoir, and hose connections for fluid leakage. Correct any fluid leaks, check the fluid level again, and refill the reservoir to the correct level.

5. CONTROL VALVE ASSEMBLY

a. Construction and Operation.

The power steering control valve assembly is threaded

on the left-hand end of the steering arm to idler arm rod. The assembly (fig. 17) consists of the control valve sleeve, the control valve housing, the centering spring

cap, and the internal parts. The centering spring cap and the sleeve are bolted to the housing. An adapter plate is installed between the cap and the housing.

The sector shaft arm (Pitman arm) ball stud, ball stud seats, ball socket spring, socket tube, and spring stop plug are installed in the control valve sleeve. The parts are held in place with a control valve spool stop screw which threads into the left-hand end of the socket tube.

The valve spool is mounted on a bolt which passes through the valve spool stop screw. A pin, installed through the stop screw, the socket tube, and the head of the bolt, maintains proper alignment of these parts. A spring, spacer, and three washers are installed on the bolt and are held in place by a self-locking nut.

A lip-type seal and a bushing are installed, in the bore of the control valve housing, at each end of the valve spool. A split, circular retainer is pressed in the sleeve end of the housing to retain the seal and bushing. The adapter plate retains the seal and bushing which are installed in the opposite end of the housing.

The valve spool has three radial lands which control the directional flow of the fluid. A ball-type check valve assembly is threaded into the bottom of the housing port through which fluid is returned to the reservoir. In addition to the return port, a pressure port admits fluid from the pump, and two ports are connected to the power cylinder by flexible hoses.

Fluid pressure is delivered from the pump to the control valve through a flexible hose. When the steering wheel is turned, the sector shaft arm moves the control valve spool against the resistance of a centering spring, within the control valve body. This action opens and closes ports in the valve body (fig. 6 and 7) which direct the fluid flow to and from the power cylinder.

The movement of the valve spool within the body is

controlled, by positive stops, to approximately 0.060 inch in each direction from center. The power assist is accomplished before the valve spool reaches the stop, thus insuring sensitive response.

As the sector shaft arm moves further, the entire control valve assembly and the steering arm to idler arm rod move as a unit assisted by the power cylinder.

When the steering wheel is stopped at any position, the movement of the steering arm to idler arm rod by the power cylinder plus the force of the centering spring moves the valve housing until the spool is in the center (neutral) position.

The valve spool also depends on hydraulic pressure as well as the centering spring for its centering force. This is accomplished by providing fluid passages between two valleys in the valve spool and the chambers between the outer lands and the housing seals. Fluid pressure in these chambers tends to move the spool away from the seals.

If the spool is moved to the right, the pressure in the chamber at the right-hand end increases in proportion to the pressure applied to the power cylinder. Thus, the centering force provides a feel at the steering wheel proportional to the effort required to turn the front wheels.

b. Overhaul.

If the control valve is not operating properly, remove the valve assembly from the car and repair the unit.

(1) **REMOVAL.** Disconnect the four hoses at the control valve, and drain the fluid from the hoses. Turn the front wheels to the right and left several times to force all the fluid from the system.

Loosen the control valve sleeve clamp bolt nut. Pull the roll pin out of the steering arm to idler arm rod.

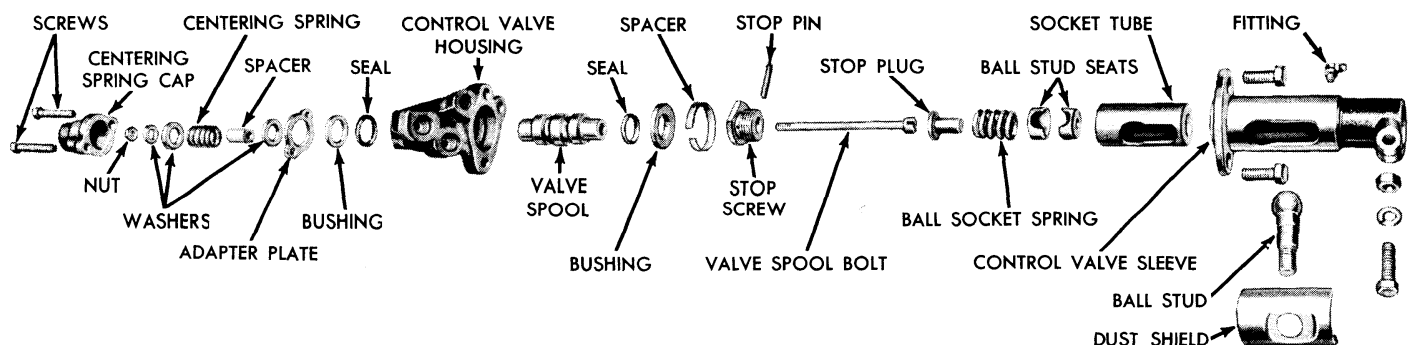
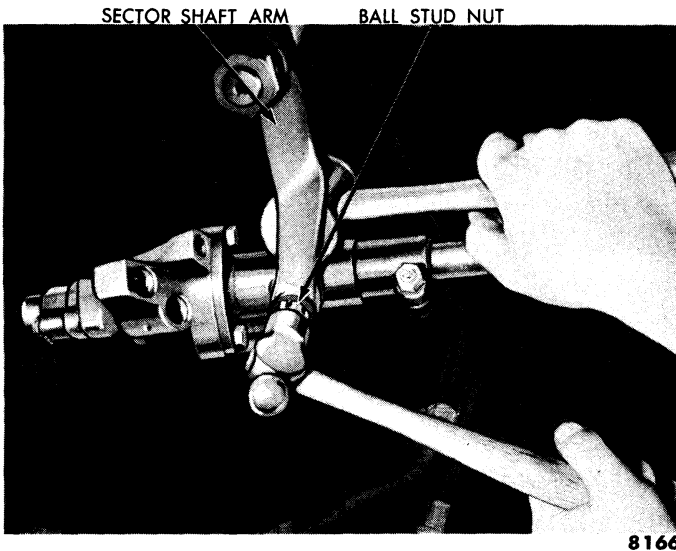

Fig. 17—Control Valve Assembly



8166

Fig. 18—Ball Stud Removal

Remove the cotter pin from the sector shaft arm to ball stud nut, then back off the nut far enough to protect the threads on the end of the ball stud. Tap the ball stud out of the sector shaft arm while holding a hammer behind the arm to absorb the shock (fig. 18).

CAUTION: Do not strike any part of the valve body while loosening the ball stud as damage may result.

Remove the ball stud nut from the stud, then raise the control valve high enough to separate the ball stud from the sector shaft arm.

Turn the front wheels fully to the left, then turn the control valve assembly in a counterclockwise direction on the steering arm to idler arm rod to remove the assembly from the rod (Fig. 19).

(2) **DISASSEMBLY.** Place the control valve assem-

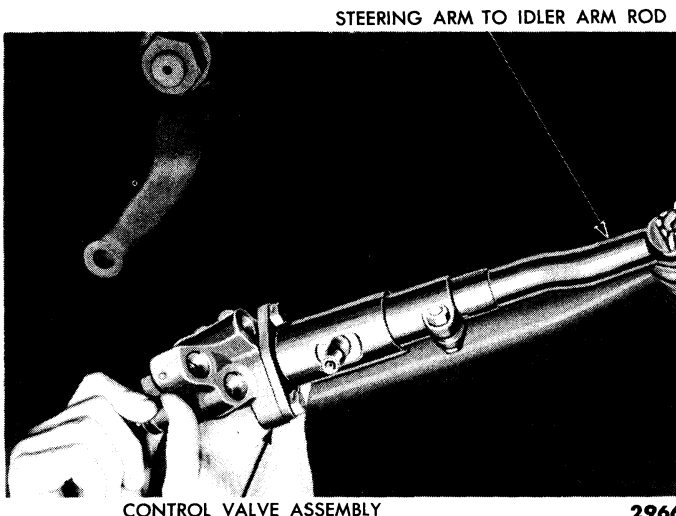

2966

Fig. 19—Control Valve Removal

bly in a vise to hold it firmly at the valve sleeve flange.

CAUTION: Do not clamp the vise around any other part of the valve housing as damage to the valve housing or valve spool may result.

Cut and remove the safety lock wires from the bolts that attach the control valve sleeve to the control valve housing. Remove the two centering spring cap bolts, then remove the cap from the valve housing.

Remove the nut from the end of the control valve spool bolt, then remove the washers, spacer, centering spring, adapter plate, and bushing from the control valve housing.

Remove the two bolts that attach the control valve sleeve to the control valve housing, then separate the sleeve and the housing. Remove the lubrication fitting from the control valve sleeve.

Remove the control valve spool from the centering spring end of the valve housing (fig. 20). Remove the seal from the valve spool.

Remove the spacer, bushing, and seal from the sleeve end of the control valve housing (fig. 21).

Place the control valve spool regulator stop screw in a vise, pull the valve spool bolt out from the valve sleeve to take up the slack, then drive the stop pin out of the valve spool stop screw (fig. 22).

Turn the control valve sleeve in a counterclockwise direction on the valve spool stop screw to remove the sleeve from the screw (fig. 23). Remove the valve spool bolt from the valve spool stop screw.

Remove the dust shield from the control valve sleeve. Slide the ball stud toward the enlarged end of the slot in the valve sleeve, then remove the ball stud from the

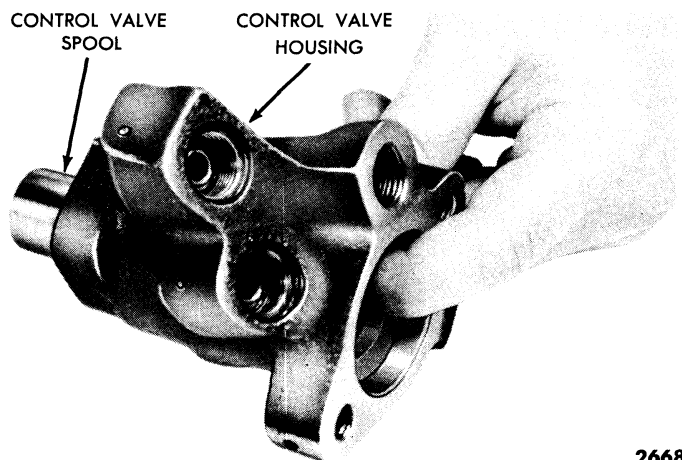

2668

Fig. 20—Control Valve Spool Removal

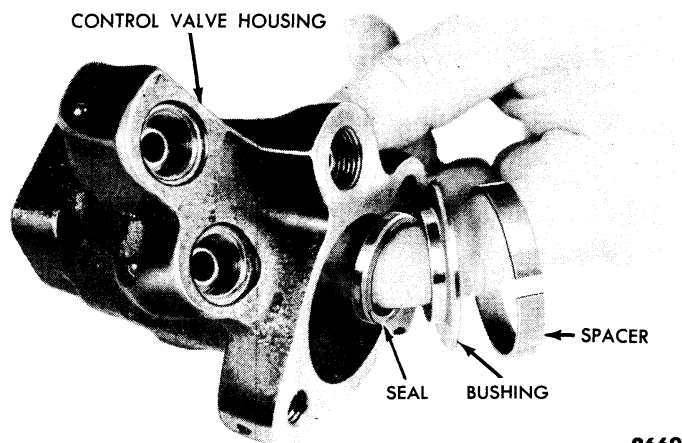

2669

Fig. 21—Spacer, Bushing, and Seal Removal

sleeve (fig. 24). Remove the socket tube, stop plug, ball socket spring, and ball stud seats from the control valve sleeve (fig. 25).

(3) **INSPECTION AND REPAIR.** Clean all the parts of the control valve assembly thoroughly, and inspect them for wear or damage. Replace any parts if necessary.

Inspect the control valve seals and bushings for wear or damage. Examine the lips of the seals carefully for nicks or scratches that could allow fluid to escape from the valve. Examine the bushings for nicks or scores. Replace the seals and bushings if necessary.

Inspect the control valve spool carefully for burrs and scoring. Remove the burrs with crocus cloth.

CAUTION: *Do not round off the sharp edges on the valve spool or the operation of the valve may be affected.*

Inspect the control valve housing for burrs and scored

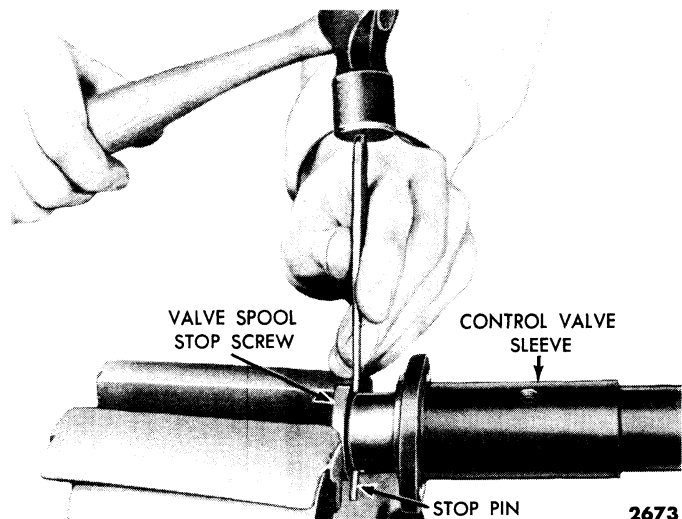

2673

Fig. 22—Control Valve Spool Stop Pin Removal

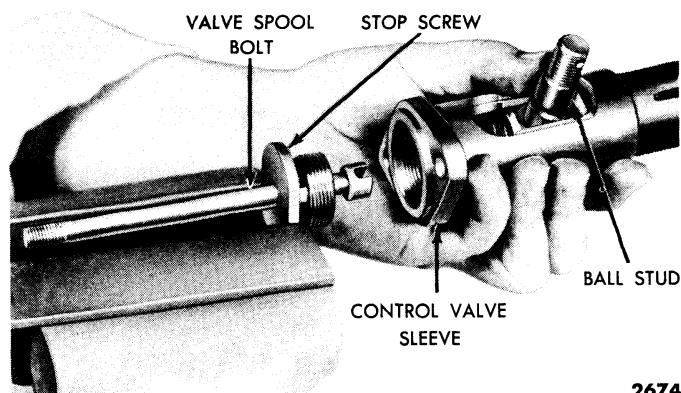

2674

Fig. 23—Control Valve Sleeve Removal

or damaged surfaces. Remove the burrs with crocus cloth.

Dry the valve spool and housing thoroughly, and insert the valve into the housing. The valve spool should fall freely of its own weight in the housing (the specified valve spool to control valve housing clearance is 0.0002-0.0009 inch).

If the relief valve (check valve) assembly in the return line port should be replaced, proceed as follows:

Tap the existing hole in the return line hose seat with a $\frac{3}{8}$ -inch starting tap.

CAUTION: *Remove all chips from the hole after tapping.*

Place a nut and large flat washer on a $\frac{3}{8}$ -inch bolt. The washer must be large enough to cover the return line hose seat port.

Insert the bolt in the tapped hole, then use it as a puller to remove the return line hose seat. Remove the check valve assembly with a screwdriver.

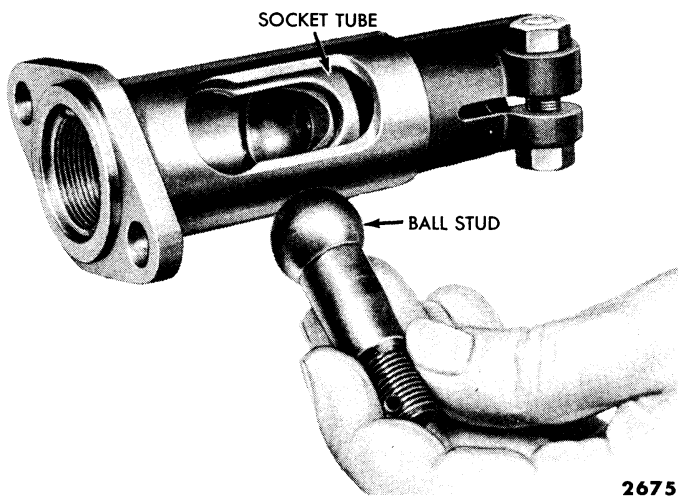

2675

Fig. 24—Ball Stud Removal

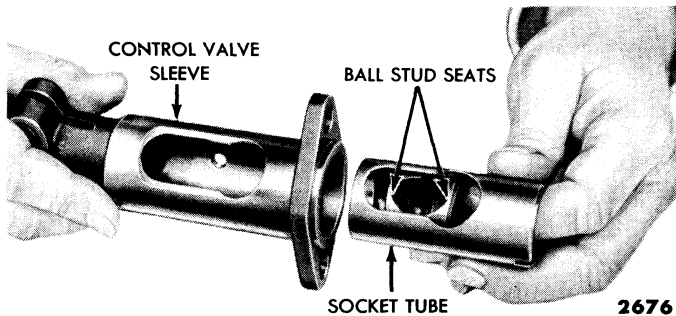

Fig. 25—Socket Tube Installation

Install a new check valve assembly in the hole, then position a new return line hose seat in the port. Thread a $\frac{5}{8}$ -inch bolt into the return line hose seat port, and tighten the bolt sufficiently to bottom the seat in the port.

Use the same procedures to replace the control valve to power cylinder hose seats. The same procedures are used to replace the pressure line hose seat except that a $\frac{1}{4}$ -inch tap is used to thread the hole, and a $\frac{1}{4}$ -inch nut and bolt are used as a puller.

Inspect the mating surfaces of the control valve socket tube and the control valve sleeve for wear or damage. The surfaces should be free of burrs and scores. Minor burrs and scores may be removed with crocus cloth. Check the fit of the socket tube in the control valve sleeve. The socket tube should slide freely in the valve sleeve.

(4) **ASSEMBLY.** Lubricate the control valve assembly parts with Automatic Transmission Fluid—Type A before assembly. Check each part, as it is installed, for dirt or foreign matter which might impair the operation of the system.

Position the ball stud seats in the socket tube, then position the socket tube in the control valve sleeve (fig. 25). Lubricate, and then insert the ball stud in the sleeve through the large end of the slot (fig. 24).

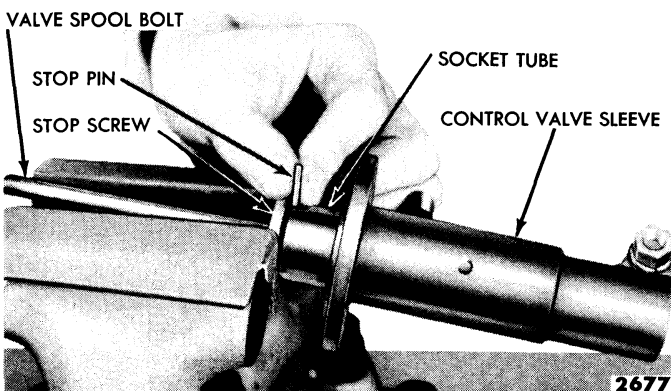

Fig. 26—Stop Pin Installation

CAUTION: *Be sure that the ball stud seats are properly aligned in the socket tube.*

Place the ball socket spring in the socket tube, then position the stop screw in the socket tube. Tighten the stop screw securely, then back it off until the nearest hole in the stop screw is aligned with the slot in the socket tube.

Install the stop pin in the valve sleeve and stop screw (fig. 26).

Install the dust shield and the lubrication fitting on the control valve sleeve. Make sure that the tip of the lubrication fitting points toward the left side of the car, and is turned in as far as possible.

Cover the control valve spool and seals with a light film of Automatic Transmission Fluid—Type A. Insert the large end of the spool in the right-hand end of the control valve housing. Rotate the valve spool while inserting it in the housing.

Move the valve spool to the centering spring end of the housing, then position the small seal, bushing, and spacer in the sleeve end of the housing. Press the valve spool against the inner lip of the seal and, at the same time, guide the lip of the seal over the spool with a small screwdriver (fig. 27).

CAUTION: *Do not nick or scratch the control valve spool seals during installation or fluid leakage will result when the power steering system is operating.*

Place the sleeve end of the control valve housing on a flat surface so that the seal, bushing and spacer are at the bottom end. Press down on the valve spool until it stops.

Carefully install the spool seal and bushing in the centering spring end of the valve housing around the large end of the valve spool. Press the spool against the

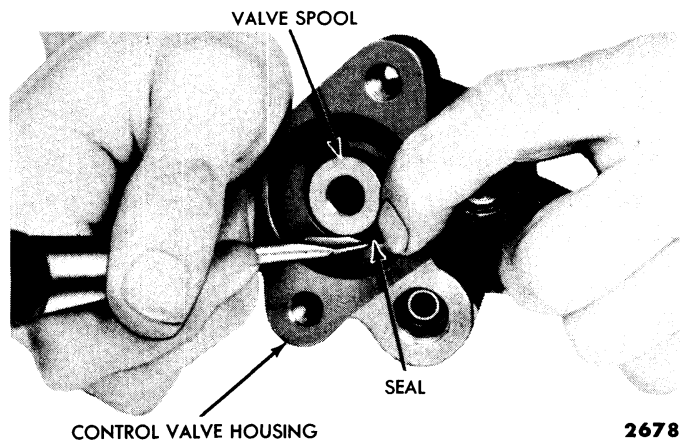
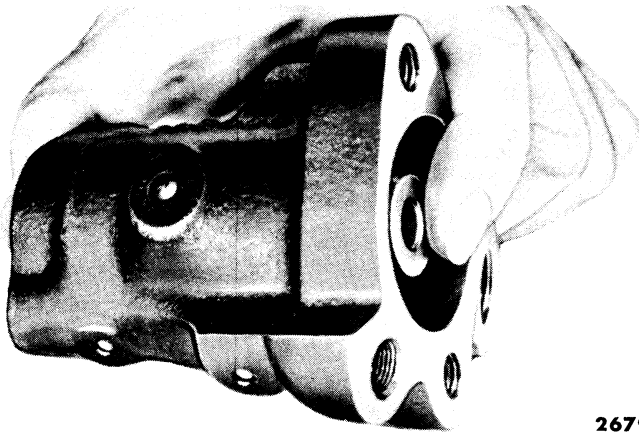

Fig. 27—Control, Valve Spool Seal Installation



2679

Fig. 28—Checking Valve Spool for Free Movement

inner lip of the seal, and guide the inner lip over the spool with a small screwdriver. Check the valve spool for freedom of movement in the housing (fig. 28).

Position the control valve sleeve assembly on the valve housing so that the ball stud is on the same side of the valve housing as the pump return line and the control valve to power cylinder line ports.

Position the valve and sleeve assembly in a vise so that the vise jaws clamp on the sleeve flange. Install the two bolts in the valve sleeve, and tighten them to 25-30 foot-pounds torque.

Place the adapter plate on the control valve housing, then position the washers, spacer, and centering spring on the valve spool bolt. Compress the centering spring, and install the nut on the spool bolt. Tighten the nut securely, then back it off not more than $\frac{1}{4}$ turn (fig. 29).

Move the ball stud back and forth in the sleeve slot to check the valve spool for freedom of movement. The spool travel should be approximately 0.060 inch in each direction from center.

Position the centering spring cap on the control valve body, then install the two cap bolts. Tighten the bolts to 10-15 foot-pounds torque.

Install new locking wires on the centering spring cap and bolts and the valve sleeve bolts.

NOTE: *The valve sleeve bolt locking wire should be positioned on the side of the sleeve opposite the dust shield.*

Install the nut on the ball stud, and clamp the nut in a vise so that the centering spring cap end of the valve assembly is at the front of the vise. Push forward on the cap end of the valve assembly to check the valve spool for freedom of movement (fig. 30).

Turn the valve assembly around so that the sleeve

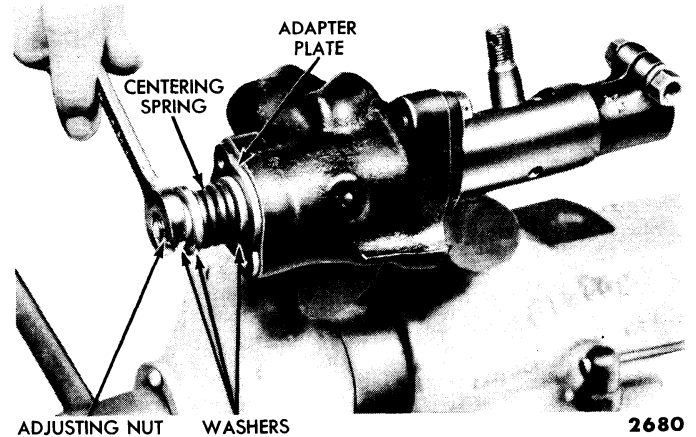

2680

Fig. 29—Centering Spring Adjustment

end is at the front of the vise. Push forward on the sleeve end to check the valve spool for freedom of movement.

(5) **INSTALLATION.** Thread the control valve assembly on the steering arm to idler arm rod until approximately four threads are still showing on the rod.

Position the sector shaft arm ball stud in the steering sector shaft arm.

Check the distance between the center of the sector shaft arm ball stud and the center of the left-hand spindle connecting rod ball stud (fig. 31). The distance on all cars except the Thunderbird should be nine (9) inches to keep the steering gear on the high point when the wheels are in the straight-ahead position. The distance on the Thunderbird should be $9\frac{1}{2}$ inches. If the distance is incorrect, disconnect the sector shaft arm ball stud from the steering arm and turn the control valve assembly clockwise to reduce the distance, or counterclockwise to increase the distance.

Position the ball stud on the sector shaft arm, then recheck the distance. When the correct distance is obtained, align the hole in the steering arm to idler arm

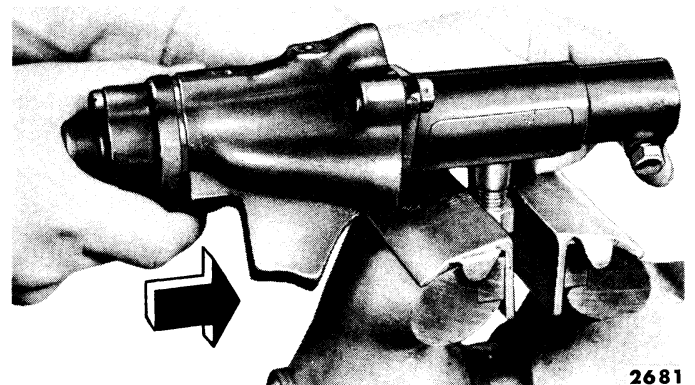

2681

Fig. 30—Checking Valve Spool Movement

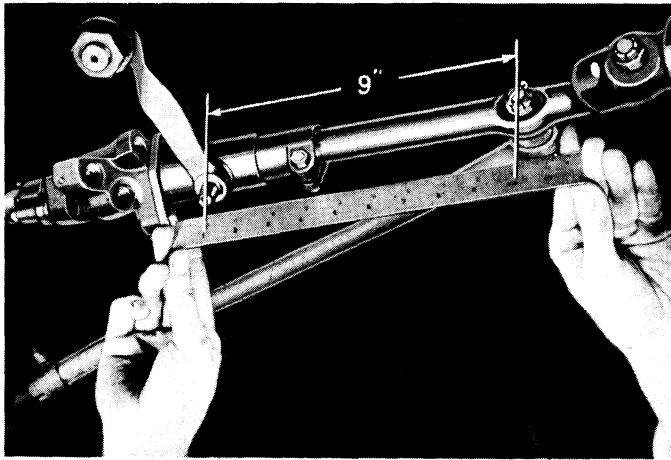

Fig. 31—Checking Sleeve Installation

rod with the slot in the control valve sleeve. Install the roll pin to lock the rod in position.

Tighten the control valve sleeve clamp bolt to 30-35 foot-pounds torque.

Install the nut on the sector shaft arm ball stud, then tighten the nut to 56-60 foot-pounds torque. Install a new cotter pin through the ball stud and nut.

Connect the pressure and return line hoses to the control valve assembly. Tighten the fittings securely. Connect the short control valve to power cylinder hose

to the lower port in the control valve. Connect the long control valve to power cylinder hose to the upper port in the control valve. Tighten all fittings securely. Check the steering wheel position when the front wheels are in the straight ahead position. If the steering wheel position is incorrect, make the adjustment at the spindle connecting rods. Check toe-in, with the engine running, and correct if necessary.

Fill the fluid reservoir to the specified level with Automatic Transmission Fluid—Type A, then bleed the system as follows:

Operate the engine at idle speed for about two minutes to warm the fluid. Check the fluid level, then check all hose connections for leaks.

Increase the engine speed to about 1000 r.p.m., then turn the steering wheel to the left and right several times.

Stop the engine, then check the control valve assembly and the hose connections for fluid leakage.

Correct any fluid leaks, check the fluid level, then refill the reservoir if necessary.

Check the pull required to turn the steering wheel with a spring scale. The maximum pull required to turn the steering wheel left or right, one revolution, on dry concrete with the engine operating at idle speed, should not exceed 12 pounds.

6. POWER CYLINDER ASSEMBLY

a. Construction and Operation.

The tubular double-walled power cylinder assembly (fig. 32) contains a piston and piston rod assembly. The right-hand end of the piston rod is attached to the idler arm mounting bracket with a nut and locknut. Two rubber bushings and two washers insulate the piston rod from the bracket. A spring-loaded, lip-type seal, a dust seal, and a scraper are installed in the rod end of the cylinder, and are held in place by a snap ring. The left-hand end of the power cylinder is mounted on a stud on the steering arm to idler arm rod, and is held in place with a washer and locknut. Two rubber bushings, installed between this stud and the stud hole in the end of the power cylinder, cushion the cylinder against road shock.

Two flexible hoses connect the power cylinder with the control valve assembly (fig. 5). Fluid flows through one line to the piston rod end of the cylinder. The other line carries fluid directly into the piston end of the cylinder. Both lines also return the fluid to the control valve.

The fluid enters the power cylinder either to the left or right of the piston, depending on the turn being made. When the fluid pressure in one end of the power cylinder becomes great enough, the cylinder moves on the piston rod to provide the power assist. As the cylinder moves, the fluid in the opposite end of the cylinder is forced out and returns to the reservoir through the control valve.

b. Overhaul.

If the power cylinder assembly is not operating properly, or if leaks are found in the unit, remove the entire assembly from the car and replace the worn or damaged parts.

(1) **REMOVAL.** Disconnect the control valve to power cylinder hoses at the power cylinder. Fasten the ends of the hoses in a raised position to prevent fluid drainage. Move the front wheels to the left and right several times to force all the fluid from the cylinder.

Remove the locknut and nut that attach the power cylinder piston rod to the idler arm bracket. Remove

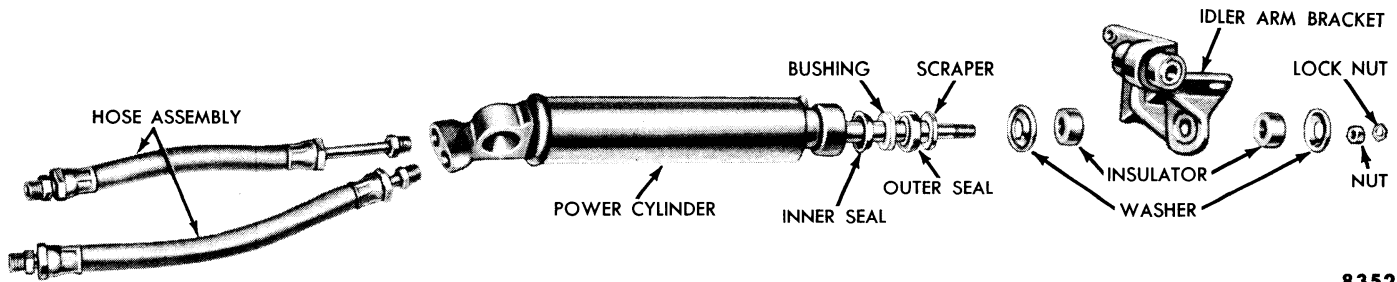

8352

Fig. 32—Power Cylinder Assembly

the outer washer and rubber insulator (bushing) from the end of the piston rod, then remove the piston rod from the bracket. Remove the inner rubber bushing and washer from the piston rod.

Remove the locknut that secures the power cylinder to the mounting stud in the steering arm to idler arm rod. Remove the outer washer and rubber bushing, then remove the power cylinder from the stud. Remove the inner bushing from the stud.

(2) **CLEANING, INSPECTION, AND REPLACEMENT.** Clean all dirt and fluid from the outside of the power cylinder assembly.

The construction of the power cylinder assembly does not permit repairing the piston or the piston rod. If the cylinder, piston, or piston rod are worn or damaged, the entire assembly must be replaced as a unit.

However, the seals and hose seats can be replaced if they become worn or damaged.

(a) **PISTON ROD SEALS.** Clamp the power cylinder in a vise. Remove the snap ring from the piston rod end of the power cylinder with the tool shown in fig. 33. Pull the piston rod outward to remove the dust seal and washer from the cylinder.

Apply compressed air to the ports in the end of the cylinder, and blow the retainer and seal out the end of

the power cylinder.

Examine the seals for wear or damage, and replace them if necessary.

Lubricate the fluid seal, then install the seal, retainer, and dust seal in the power cylinder with a $\frac{7}{8}$ -inch deep wall socket (fig. 34). Install the washer.

Install the snap ring in the end of the power cylinder with the tool shown in fig. 33.

(b) **CONTROL VALVE TO POWER CYLINDER HOSE SEATS.** Tap the existing holes in the control valve to power cylinder hose seats with a $\frac{3}{8}$ -inch starting tap.

CAUTION: Remove all chips from the holes after tapping.

Place a nut and large flat washer on a $\frac{3}{8}$ -inch bolt. The washer must be large enough to cover each hose seat port. Insert the bolt in one of the tapped holes and use it as a puller to remove the hose seat. Follow the same procedure to remove the other hose seat.

Position a new seat in one of the hose seat ports, then thread a $\frac{5}{8}$ -18 bolt in the port until the hose seat bottoms in the port. Follow the same procedure to install the other hose seat.

(3) **INSTALLATION.** Inspect all the washers and rubber bushings for wear or damage, and replace them

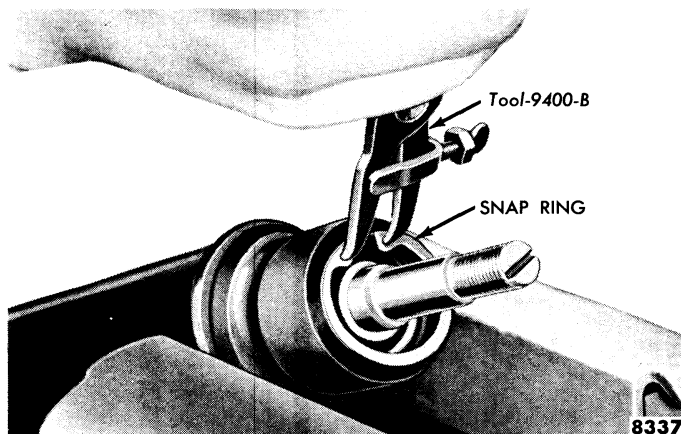

8337

Fig. 33—Power Cylinder Snap Ring Removal

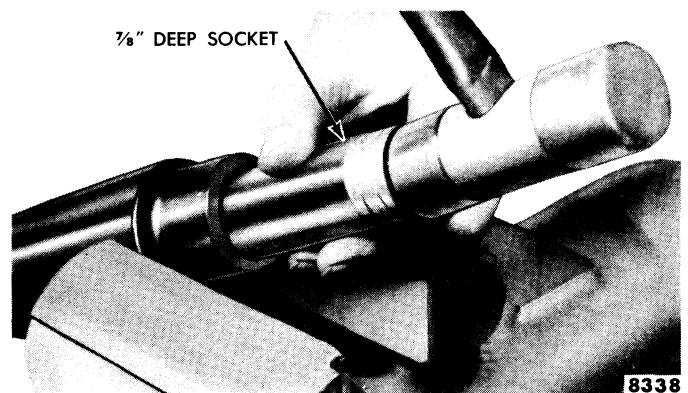

8338

Fig. 34—Fluid Seal-Dust Seal, and Washer Installation

wherever necessary.

Install the inner washer and bushing on the power cylinder piston rod, then place the bushing on the steering arm to idler arm rod stud. Position the piston rod in the idler arm bracket, then position the power cylinder on the mounting stud.

Install the bushing, outer washer, and nut on the cylinder mounting stud, and tighten the nut until it bottoms against the washer. If a new nut is used, tighten the nut to 60-70 foot-pounds torque. If a used nut is installed, tighten the nut to 50-60 foot-pounds torque.

Install the outer bushing, washer, and nut on the piston rod, and tighten the nut until it bottoms against the washer. Tighten the nut to 40-50 foot-pounds torque. Install the locknut and tighten it to 40-50 inch-pounds torque (finger tight plus $\frac{1}{3}$ turn).

Install the control valve to power cylinder hoses so that the short hose connects to the forward port in the power cylinder.

Fill the fluid reservoir to the specified level with Automatic Transmission Fluid—Type A, then bleed the system as follows:

Operate the engine at idle speed for about two minutes to warm the fluid. Check the fluid level, then check all hose connections for leaks.

Increase the engine speed to about 1000 r.p.m., then turn the steering wheel to the left and right several times.

Stop the engine, then check the power cylinder and the hose connections for fluid leakage. Correct any fluid leaks, check the fluid level, then refill the reservoir if necessary.

7. STEERING LINKAGE

a. Construction.

The spindle arms, spindle connecting rods (tie-rods), steering sector shaft arm (Pitman arm), and steering gear assembly are identical to those used with conventional steering.

The right-hand end of the steering arm to idler arm rod is attached to the idler arm. The left-hand end is threaded into the control valve sleeve and is retained by the sleeve clamp bolt (fig. 1). A roll pin maintains correct alignment of the valve sleeve to the rod. The inner spindle connecting rod ball studs are installed in holes in the steering arm to idler arm rod. The studs are held in place by nuts secured with cotter pins.

The sector shaft arm is installed on a ball stud which is mounted in the control valve sleeve. The arm is retained on the stud by a nut and cotter pin.

b. Overhaul.

The overhaul information on the power steering linkage pertains only to those items which are considered part of the power steering system (fig. 35).

(1) **IDLER ARM BUSHINGS.** If the idler arm is loose in the idler arm bushings, or if the bushings are worn or damaged, the defective parts must be replaced. A kit is available which contains the idler arm, the bushings, and the washers, nuts, and cotter pins needed to secure the arm in the bushings. If replacement of the idler arm or the bushings is necessary, the entire contents of this kit should be installed.

(a) **REMOVAL.** Remove the cotter pins and nuts from the idler arm. Pull the idler arm out of the idler arm bracket and the steering arm to idler arm rod.

Remove the idler arm bushings with the tools shown in fig. 36, in the following manner:

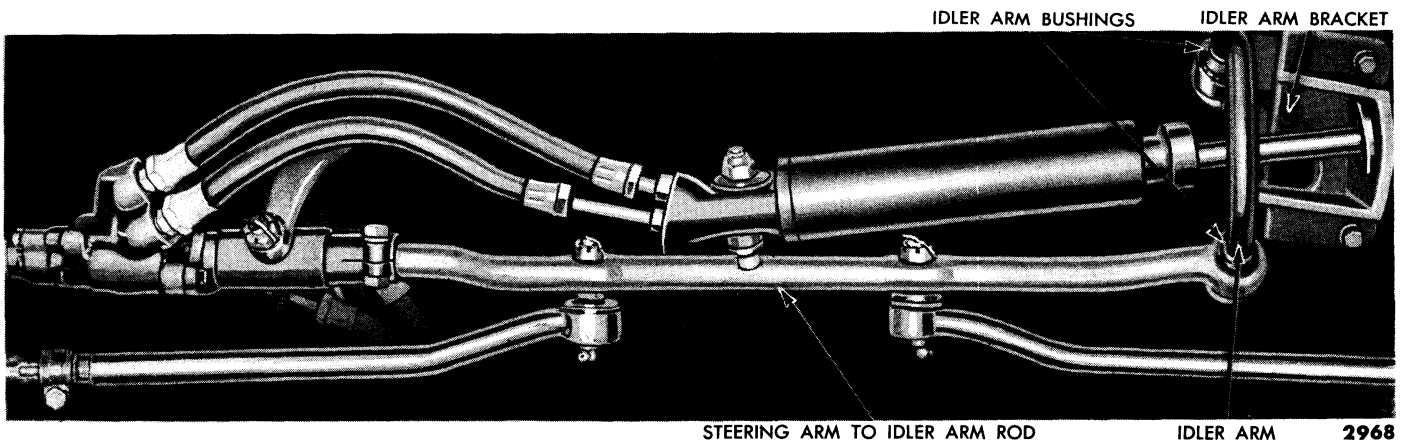

Fig. 35—Power Steering Linkage

Install the driver (Detail No. 1 of Tool T53P-3355-B) on the screw (Detail No. 3A of Tool T52L-6306-AEE).

Position the screw and driver in the bushing with the driver seated on the top of the bushing.

Position the collar (Detail No. 2 of Tool T35P-3355-B) over the driver and bushing. The chamfer on the collar must be aligned with the fillet on the bracket to permit the collar to seat squarely on the bracket.

Place the spacer (Detail No. 3 of Tool T53P-3355-B) over the lower portion of the bushing. Install the thrust bearing and hex nut (Details No. 1 and 2 of Tool T52L-6306-AEE) on the screw.

CAUTION: *Make sure the driver is entered in the collar and seated on the bushing.*

Turn the hex nut until the bushing is forced out of the bracket, then disassemble the tools and remove the old bushing.

To remove the bushing from the steering arm to idler arm rod, use the tools shown in fig. 36 installed in the same manner as described above.

(b) **INSTALLATION.** The idler arm bushings may be installed with the tools shown in fig. 37, in the following manner:

Install the driver (Detail No. 1 of Tool T53P-3355-B) on the screw (Detail No. 3A of Tool T52L-6306-AEE). Place the new bushing on the screw, then insert the screw down through the hole in the idler arm bracket.

Install the spacer (Detail No. 3 of Tool T53P-3355-B) over the driver and bushing. The chamfer on the spacer must be aligned with the fillet on the bracket to permit the spacer to seat squarely on the bracket.

Install the stop (Detail No. 4 of Tool T53P-3355-B) on the screw with the end of the stop marked "BKT" next to the underside of the bracket.

Install the thrust bearing and hex nut (Details No. 1 and No. 2 of Tool T52L-6306-AEE) on the screw.

Turn the hex nut until the bushing bottoms in the stop, then remove the tools.

To install the bushing in the steering arm to idler arm rod, position all parts of the tools, except the stop as outlined above. Position the stop on the screw with the end marked "ROD" next to the underside of the steering arm to idler arm rod.

Install the idler arm in the bushings, then install a flat washer and castellated nut on each end of the idler arm.

Turn the front wheels to the straight-ahead position. Tighten the castellated nuts to 50-60 foot-pounds torque, then install new cotter pins.

(2) **STEERING ARM TO IDLER ARM ROD.** The power cylinder mounting stud and the steering arm

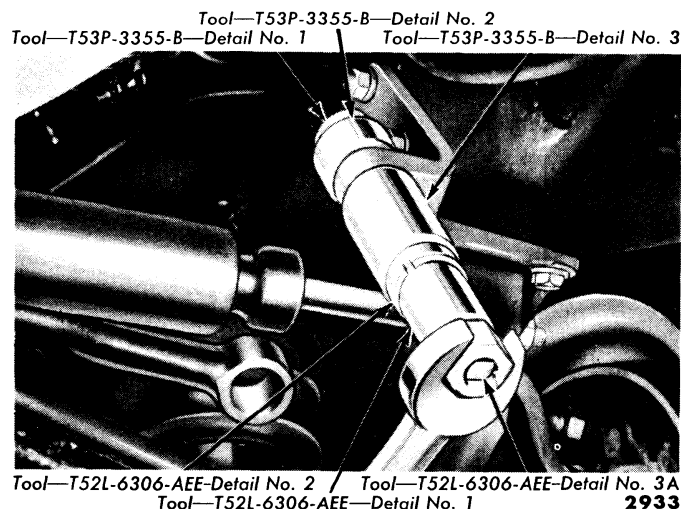

Fig. 36—Idler Arm Bushing Removal

to idler arm rod are serviced as an assembly.

If either part becomes worn or damaged, the entire assembly must be replaced. The bushing, installed in the right-hand end of the steering arm to idler arm rod, can be replaced separately.

(a) **REMOVAL.** Remove the hugnut that secures the power cylinder assembly to the stud of the steering arm to idler arm rod (fig. 35). Remove the washer and rubber bushing from the stud.

Remove the lock nut and nut that retains the power cylinder piston rod in the idler arm bracket. Slide the washer and rubber insulator off the piston rod.

Pull the power cylinder assembly off the steering arm to idler arm rod stud, pull the piston rod out of the idler arm bracket, then move the assembly up out of the way. Remove the rubber bushing from the stud.

Remove the cotter pin from the nuts which attach the spindle connecting rod studs to the steering arm to idler arm rod, then back off the nuts far enough to protect the stud threads. Tap on the stud nuts, while

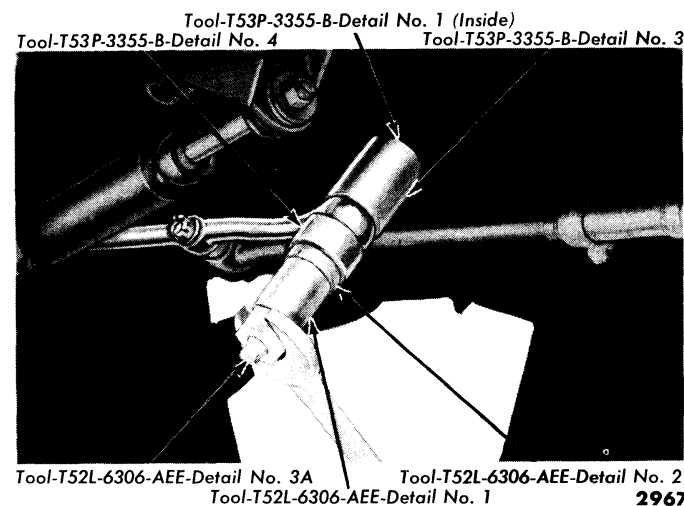

Fig. 37—Idler Arm Bushing Installation

holding a hammer behind the steering arm to idler arm rod, until the studs are loose in the rod.

Remove the stud nuts, then remove the spindle connecting rods from the steering arm to idler arm rod.

Pull the roll pin out of the steering arm to idler arm rod.

Loosen the control valve sleeve clamp bolt, then remove the cotter pin from the nut which secures the idler arm to the steering arm to idler arm rod. Hold the idler arm in place, and tap the steering arm to idler arm rod off the idler arm.

Thread the steering arm to idler arm rod out of the control valve sleeve.

If the rod is to be reinstalled on the car, clean and inspect the rod for damage. Inspect the idler arm bushing for wear or damage, and replace the bushing if necessary.

(b) **INSTALLATION.** Thread the steering arm to idler arm rod into the control valve sleeve until approximately four threads are still showing on the rod.

Position the steering arm to idler arm rod on the idler arm, then place the left-hand spindle connecting rod stud in the hole in the steering arm to idler arm rod. Install the nut.

Check the distance between the center of the steering arm ball stud and the center of the left-hand spindle connecting rod ball stud (fig. 31). The distance on all cars except the Thunderbird should be nine (9) inches to keep the steering gear on the high point when the wheels are in the straight-ahead position. The distance on the Thunderbird should be 9½ inches. If the distance is incorrect, disconnect the sector shaft arm ball stud from the steering arm and turn the control valve assembly clockwise to reduce the distance, or counterclockwise to increase the distance. When the correct distance is obtained, tighten the left-hand spindle connecting rod stud nut to 50-60 foot-pounds torque. Align the hole in the steering arm to idler arm rod with the slot in the control valve sleeve. Install the roll pin to lock the rod in position.

Tighten the control valve sleeve clamp bolt to 30-35 foot-pounds torque.

Position the right-hand spindle connecting rod stud in the tapered hole in the steering arm to idler arm rod, then install the nut on the stud. Tighten the nut to 50-60 foot-pounds torque then install a new cotter pin.

Turn the front wheel to the straight ahead position, then install the flat washer and the castellated nut on the idler arm. Tighten the nut to 50-60 foot-pounds torque, then install a new cotter pin.

Position the rubber bushing on the steering arm to idler arm rod stud.

Insert the power cylinder piston rod in the idler arm bracket, then position the power cylinder assembly on

the stud.

Place the rubber insulator and the washer on the end of the power cylinder rod, then install the nut. Tighten the nut to 40-50 foot-pounds torque, then install the locknut. Tighten the locknut to 40-50 inch-pounds torque (finger tight plus ⅓ turn).

Install the remaining rubber bushing and washer on the steering arm to idler arm rod stud, then install the hugnut that secures the power cylinder on the stud. If a new hugnut is used, tighten the nut to 60-70 foot-pounds torque. If a used hugnut is installed, tighten the nut to 50-60 foot-pounds torque.

Check the steering wheel position when the front wheels are in the straight-ahead position. If the steering wheel position is incorrect, make the adjustment at the spindle connecting rods. Check toe-in, with the engine running, and correct if necessary. Check the left-hand connecting rod clamp ears for correct position. The ears should be on the forward side of the connecting rod, with the bolts in a vertical position, to prevent interference with the control valve centering spring cover.

(3) **IDLER ARM BRACKET.** Replace the idler arm bracket (fig. 35) if the bracket is damaged or if the power cylinder piston rod mounting hole in the bracket is elongated.

(a) **REMOVAL.** Remove the idler arm from the bracket and rod. Disconnect the power cylinder piston rod from the idler arm bracket.

Remove the nuts and lock washers from the two long bolts which pass through the frame side rail and the idler arm bracket. Remove the bolt, lock washer, and flat washer which secure the bracket to the bottom of the frame side rail, then remove the bracket.

Inspect the idler arm bushing installed in the idler arm bracket. If the bushing is in good condition, remove the bushing with the tools shown in fig. 36, then install the bushing in the new bracket with the tools shown in fig. 37. If the bushing is worn or damaged, install a new bushing in the new bracket.

(b) **INSTALLATION.** Position the new idler arm bracket on the frame side rail with the bolt holes in the bracket aligned with the holes in the rail.

Install the two long bolts that pass through the frame side member, then install a lock washer and nut on each bolt. Tighten the nuts to 30-35 foot-pounds torque. Place a lock washer and a flat washer on the bolt which secures the bracket to the bottom of the frame side member, then install the bolt. Tighten the bolt to 30-35 foot-pounds torque.

Position the idler arm in the bushings in the idler arm bracket and the steering arm to idler arm rod. Install a flat washer and nut on each end of the idler arm. Turn the front wheels to the straight-ahead position, then tighten the nuts to 50-60 foot-pounds torque. Secure the nuts in place with new cotter pins.

Part Two
CHASSIS
 Chapter
 V
Brakes

Section		Page
1	Trouble Shooting	206
2	Adjustments	207
3	Hydraulic System	208
4	Brake Assemblies	212
5	Brake Drums	213
6	Vacuum Booster	214
7	Parking Brakes	216

The standard brakes (fig. 1) used on Ford cars are of the four-wheel hydraulic, single-anchor, internal-expanding type. Self-energizing primary and secondary brake shoes with duo-servo action are installed at each wheel.

When the brake pedal is depressed, the piston in the master cylinder (fig. 1) forces hydraulic pressure against the wheel cylinder pistons. The pistons push the brake shoes outward against the brake drums. When the brake pedal is released, the hydraulic pressure is

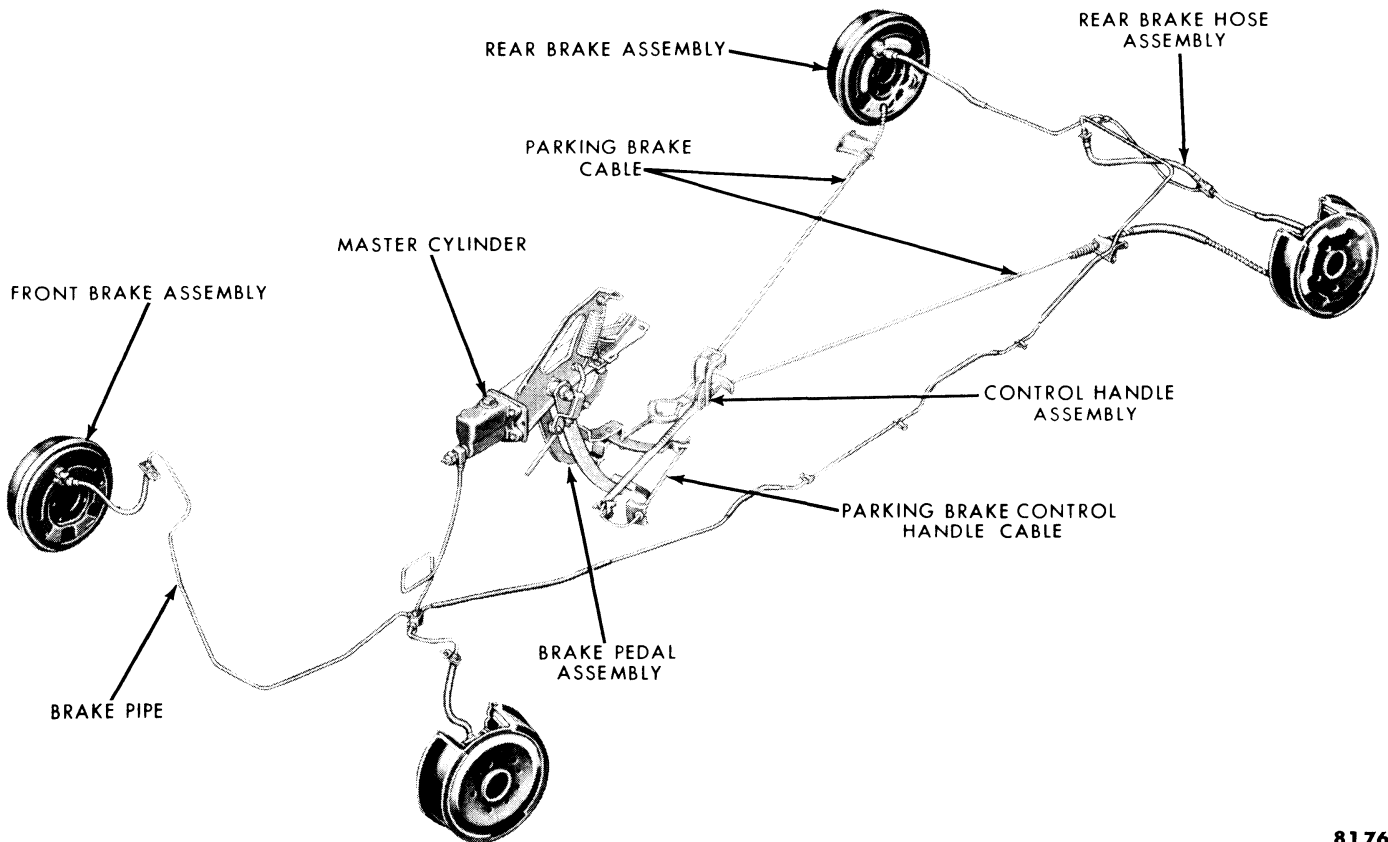

Fig. 1—Standard Hydraulic Brakes

reduced, and the brake shoe retracting springs pull the shoes away from the drums.

Power brakes, which consist of a vacuum-type brake booster installed in the standard hydraulic system, are available as optional equipment for all cars.

1. TROUBLE SHOOTING

Separate trouble-shooting procedures are given in this section for the hydraulic system and for the vacuum booster.

a. Hydraulic System.

The symptoms given here may be caused by troubles in the hydraulic system used with either standard or power brakes.

(1) **BRAKES LOCK DURING OPERATION.** Check for an improperly adjusted brake pedal, a restricted bypass port in the master cylinder, swollen master cylinder piston cups, or sticking wheel cylinder pistons caused by dirty or contaminated brake fluid.

NOTE: *If the car must be moved when the brakes are locked, open a wheel cylinder bleeder screw for a moment to allow a few drops of brake fluid to leak out of the system. This temporary fix will relieve the hydraulic pressure and free the brakes, but will not correct the cause of the trouble.*

Adjust the brake pedal if necessary. If the adjustment does not correct the trouble, check the condition of the brake fluid and replace it if it is dirty or contaminated. If the trouble is in the master cylinder, replace the piston and cup assembly. If necessary, rebuild the wheel cylinder.

(2) **BRAKES DO NOT APPLY.** If air has entered the hydraulic lines, the brake pedal will have a "spongy" feel when depressed and may travel all the way to the floor without developing enough hydraulic pressure to stop the car.

Air can enter the hydraulic system if the brake fluid level in the master cylinder reservoir is too low, if excessive clearance exists between the brake linings and the drums, or if the wheel cylinder pistons are not held firmly in place while servicing the brake shoes.

Bleed the hydraulic system to eliminate the air. Be sure that the brake fluid level in the master cylinder reservoir is high enough. Eliminate excessive clearance between the shoes and drum by adjusting the brakes.

(3) **LOW PEDAL RESERVE.** During normal operation, a little of the brake lining wears away each time the brakes are applied. This wear can be compensated for by a brake adjustment. In some cases it may be necessary to add brake fluid to the master cylinder.

With power brakes, the master cylinder piston forces the hydraulic pressure into the vacuum booster which operates the wheel cylinder pistons.

An independent manually-operated parking brake controls the rear wheel brake shoes through a mechanical linkage.

(4) **UNEVEN, NOISY, GRABBING, OR HARD BRAKES.** When any of these conditions exist, remove the brake drums so that a complete inspection of the brake assemblies can be made to determine the cause of the trouble.

Excessive dust and dirt in the brake lining rivet holes or in the brake drum can cause brake squeal. Remove the dirt with a scraper and an air hose.

Out-of-round drums, improper brake shoe adjustment, warped or out-of-alignment shoes and webs, and glazed linings are a few of the causes for uneven, noisy, grabbing, or hard brakes. Adjust or replace the necessary parts to eliminate the trouble. Lining glaze can be removed by rubbing the lining with medium-grade sandpaper until a dull finish is obtained on the lining.

Always adjust the brake assemblies after correcting these brake troubles.

b. Vacuum Booster.

The more common troubles which may develop in the power brake vacuum booster are discussed below.

(1) **BRAKE PEDAL KICKS BACK—ENGINE RUNNING.** This condition may be caused by slave piston cups leaking, a hydraulic check valve leak, or an intermittent vacuum leak in the unit. Remove and overhaul the booster unit.

(2) **LOSS OF FLUID.** Loss of fluid in the hydraulic system may be caused by loose connections, master or wheel cylinders leaking, or broken hydraulic lines. To correct these conditions, locate and repair the leaks.

If the booster leaks at the hydraulic (slave) cylinder end cap, install a new gasket. If leaks are found at the bleeder screw, hydraulic line outlet, stop light switch, or at the master cylinder to booster hydraulic pipe inlet connection, tighten the connections. Remove and overhaul the booster when leaks exist at the push rod seals, control valve piston cup, or at the push rod bushing seal. After the leaks have been corrected, bleed the hydraulic system.

(3) **BRAKES DO NOT RELEASE—ENGINE RUNNING.** This condition may be caused by the control valve piston sticking, the hydraulic (slave piston) check valve sticking, or a broken or weak control valve spring.

Remove and overhaul the booster unit to correct these difficulties. A dented or leaky diaphragm body will also prevent the release of the brakes. Disassemble the body and make the necessary repairs.

(4) **VACUUM LEAK WITH BRAKES RELEASED—ENGINE IDLES NORMALLY.** This type of a vacuum leak may be caused by a defective "O" ring seal or body to slave cylinder gasket, dirty or worn atmospheric valve seal, or a defective or dirty vacuum check valve. These conditions may be eliminated by removing and overhauling the booster.

(5) **VACUUM LEAKS WITH BRAKES RELEASED**

—**ROUGH ENGINE IDLE.** This type of a leak is usually caused by a leaking diaphragm in the body, a leaking control valve piston or diaphragm, or a leaking control valve vacuum valve seal. Remove and overhaul the booster unit to correct these difficulties.

(6) **HARD PEDAL—INDICATING INOPERATIVE OR WEAK BOOSTER.** This condition may be caused by a clogged air cleaner element or a sticking hydraulic cylinder (slave cylinder) piston. The booster may be leaking air at the atmospheric valve seal, control valve diaphragm, control valve piston, or the power diaphragm. The condition can be fixed by replacing the air cleaner felt or by removing and overhauling the booster.

2. ADJUSTMENTS

The brakes should be adjusted when lining wear has reduced the brake pedal reserve to less than one-half the total travel to the floor.

Before adjusting the brake shoes or the brake pedal perform the recommended preliminary inspection operations.

a. Preliminary Inspection.

Remove one front wheel and drum, and check the drum and brake shoes for the following conditions:

- (1) Brake drum scored.
- (2) Brake lining coated with brake fluid or grease.
- (3) Brake lining worn to less than $\frac{1}{32}$ inch from the top of the rivet heads.
- (4) Brake lining not making full contact with drum.

If the drum and brake shoes are in good condition, install the wheel and drum, and continue the preliminary inspection operations.

NOTE: *It may be assumed that the condition of the linings and drums at the other three wheels is approximately the same as that found at the wheel that was removed.*

Add enough brake fluid to the master cylinder to bring the level within $\frac{1}{2}$ inch of the top of the filler neck.

NOTE: *Use heavy duty brake fluid (1A-19542-A or B) only.*

Jack up all four wheels. Be sure the parking brake lever is in the fully released position. Check the cables to the rear brakes to make certain the cables have not been adjusted so that the shoes have been moved off their anchor pin seat (partially applied).

Check the front brake anchor pin nut with a wrench. If the nut is loose, tighten it securely.

b. Brake Shoe Adjustment.

The brake drums should be at normal room temperature when making adjustments. If the brakes are adjusted when the drums are hot and expanded, the shoes may drag when the drums cool and contract.

Raise the car and remove the cover from the adjusting hole in the carrier plate. If the car is raised on a frame-contact type hoist, disconnect the parking brake equalizer rod from the equalizer lever (fig. 16) so that the parking brakes will not be partially applied when the rear axle sags on the hoist. Expand the brake shoes by turning the adjusting screw (fig. 2) until the shoes contact the drum. Back off the adjusting screw 10 to 12 notches so that the drum rotates without drag.

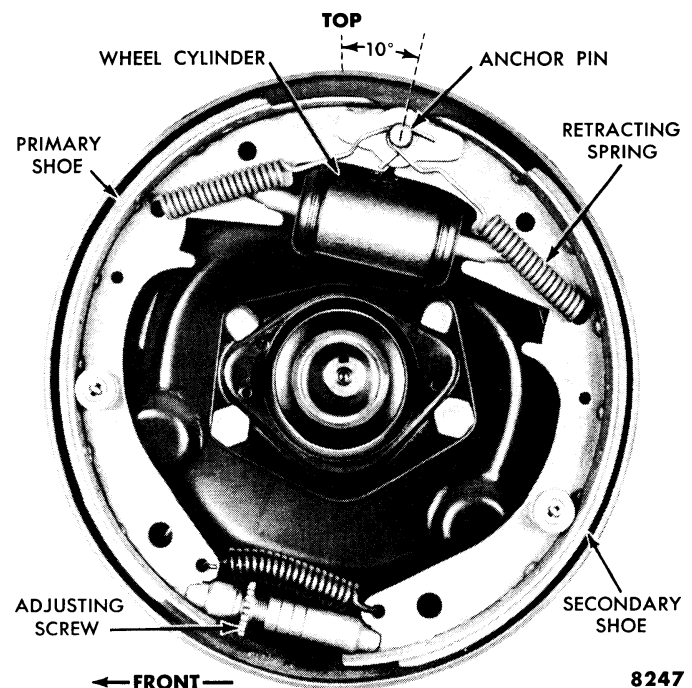

Fig. 2—Front Brake Assembly

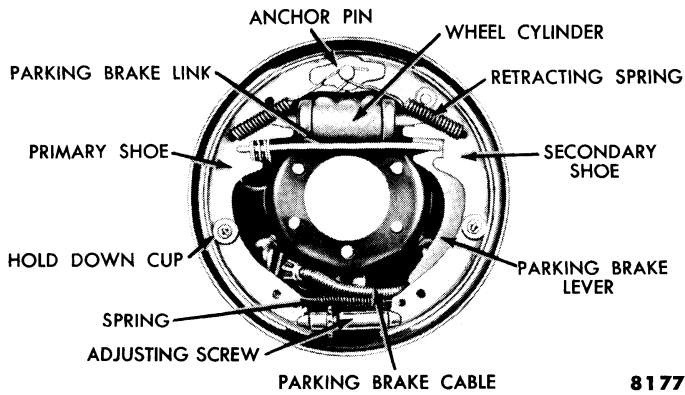

Fig. 3—Rear Brake Assembly

If the drum does not turn freely, remove the drum, blow out the dust from the linings, and apply Lubriplate to the points where the brake shoes contact the carrier plate. Install the drum, and adjust the brake shoes. Install the adjusting hole cover and the wheel.

The anchor pin is non-adjustable and cannot be moved to adjust the brake shoes. Do not remove the anchor pin from the carrier plate.

Check and adjust the other three brake assemblies. When adjusting the rear brake shoes (fig. 3), check the parking brake cables for proper adjustment. Make sure that the equalizer lever is operating freely.

Apply the brakes and measure the distance from the pedal pad to the floor board. If this distance is less than one-half the total travel, too much clearance exists between the shoes and the drums, and further adjustment is necessary. Road test the car.

c. Brake Pedal Adjustment.

When the brake pedal free travel is less than $\frac{5}{16}$ inch,

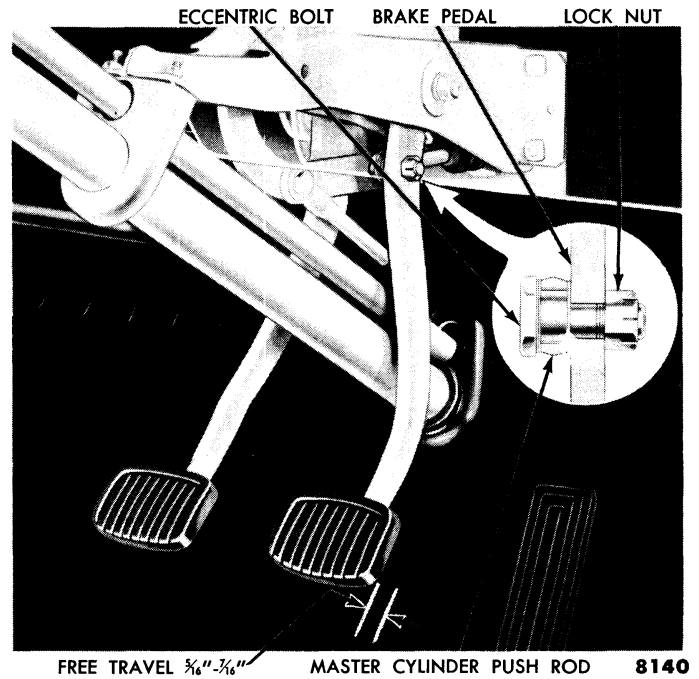

Fig. 4—Brake Pedal Free Travel Adjustment

or more than $\frac{7}{16}$ inch (fig. 4), the pedal should be adjusted. The pedal free travel, which is the movement of the brake pedal before the push rod touches the master cylinder piston, may be checked by hand pressure on the brake pedal pad.

To adjust the pedal free travel, rotate the eccentric bolt which fastens the brake pedal assembly to the master cylinder push rod assembly (fig. 4). Loosen the lock nut, then rotate the eccentric bolt until the free travel is within limits. Hold the bolt and tighten the lock nut to 25-30 foot-pounds torque. Recheck the pedal free travel to make sure that the adjustment did not change when the nut was tightened.

3. HYDRAULIC SYSTEM

The hydraulic system, which consists of the master cylinder, the wheel cylinders, and the connecting lines, is the same for both the standard brakes and the power brakes. The vacuum booster, which is installed in the power brake hydraulic system, is discussed in Section 6 of this chapter.

a. Serviceability Tests.

The hydraulic system serviceability tests for the standard brakes differ from those for the power brakes.

(1) **STANDARD BRAKES.** Depress the brake pedal and watch the pedal travel. If the travel is more than one-half the distance between the pedal pad and the

floor, a brake adjustment is needed. Check the brake pedal free travel, and adjust the pedal if necessary.

Hold the brake pedal in the fully-depressed position. If the pedal moves slowly toward the floor, check for faulty master cylinder or wheel cylinder piston cups, and for leaks in the hydraulic system. If the brake pedal has a spongy feel, bleed the system.

Road test the car and apply the brakes at a speed of about 20 m.p.h. to see if the car stops evenly.

(2) **POWER BRAKES.** Two separate serviceability tests are needed for the power brakes.

(a) **SYSTEM PERFORMANCE TEST.** With the engine

stopped, eliminate all vacuum from the system by depressing the brake pedal several times. Depress the pedal half way to the floor and note the effort required to hold the pedal in this position. Start the engine. If the vacuum system is operating properly, less foot pressure will be required to hold the pedal in the applied position. If no change is noticed in the pressure required to hold the pedal in this position, the vacuum system is not functioning properly and the vacuum tests should be performed.

Stop the engine and eliminate all vacuum from the system by depressing the brake pedal several times. Depress the pedal half way to the floor, then maintain foot pressure on the pedal. If the pedal gradually moves downward under this pressure, the hydraulic system is leaking and the hydraulic pressure tests should be performed.

(b) **VACUUM AND HYDRAULIC PRESSURE TESTS.** Connect a vacuum gauge between the check valve and the booster assembly. Run the engine at idle speed, and check the reading on the vacuum gauge. The gauge should register 18 to 21 inches of vacuum. Stop the engine and note the rate of vacuum drop. If the vacuum drops more than one inch in 15 seconds, the check valve is leaking. If the vacuum reading does not reach 18 inches or is unsteady, an engine tune-up is needed.

Reconnect the check valve to the booster.

With the engine running, depress the brake pedal all the way. Hold the pedal in this position for one minute. Any downward movement of the pedal during this time indicates a brake fluid leak. Any kick-back of the pedal indicates a vacuum leak.

b. Bleeding Hydraulic System.

If air gets into the hydraulic system, the brake pedal will have a spongy action, and it will be necessary to bleed the brakes to correct this condition. When any part of the hydraulic system is disconnected, bleed the brakes, one wheel cylinder at a time, to be sure all air is expelled from the system.

A hydraulic system may be bled manually or with pressure bleeding equipment. Separate manual and pressure bleeding procedures are provided for both the standard and power brakes.

(1) **STANDARD BRAKES.** Always use new brake fluid when bleeding the hydraulic system. Never use fluid which has been taken from the system.

(a) **MANUAL BLEEDING.** Keep the reservoir filled with fluid during the bleeding operation. Attach a rubber drain tube to the bleeder screw (fig. 5) at the wheel cylinder. Submerge the free end of the tube in a container partially filled with clean fluid. Loosen the bleeder screw, and depress the foot pedal slowly by hand.

Allow the return spring to return the pedal very slowly to the released position. This produces a pumping action which forces the fluid through the tubing and into the wheel cylinder carrying with it any air that may be present.

Observe the flow of fluid from the hose. When air bubbles cease to appear in the fluid stream, close the bleeder connection. Repeat this operation at each wheel until all wheel cylinders have been bled. Add new fluid to the master cylinder after each wheel cylinder is bled. When the bleeding operation is complete, refill the master cylinder with new fluid.

(b) **PRESSURE BLEEDING.** Make certain there is enough brake fluid in the bleed tank, and that the tank is charged with 10 to 30 pounds air pressure. Fill the master cylinder with brake fluid and attach the hose from the bleeder tank to the master cylinder. Attach a rubber drain tube to the bleeder screw at one of the wheel cylinders. Submerge the end of the tube in a container partially filled with clean fluid. Loosen the bleeder screw, then open the valve on the bleeder tank to admit the pressure to the master cylinder. Observe the flow of fluid from the drain tube. When air bubbles cease to appear in the fluid stream, close the bleeder screw. Repeat the operation at each wheel. When the bleeding operation is completed, refill the master cylinder.

(2) **POWER BRAKES.** Always use new brake fluid when bleeding the hydraulic system. Never use fluid which has been taken from the system.

Bleed the vacuum booster first, then bleed the wheel cylinders in the usual manner.

(a) **MANUAL BLEEDING.** With the engine off, depress the brake pedal several times to eliminate the vacuum in the system. Keep the master cylinder reservoir filled with fluid during the bleeding operation.

Attach a drain tube to the bleeder screw. Submerge the free end of the tube in a container partially filled with clean fluid. Loosen the bleeder screw, then depress the brake pedal slowly by hand. Allow the return spring to return the pedal very slowly to the released position. Repeat this procedure until fluid free of air bubbles flows from the submerged end of the tube. Close the bleeder screw, and remove the drain tube. Using the same method, bleed the wheel cylinders with the longest hydraulic lines first, and the short lines last.

(b) **PRESSURE BLEEDING.** Make certain there is enough brake fluid in the bleeder tank before starting and that the air pressure is from 10 to 30 pounds. Fill the master cylinder with brake fluid, and attach the bleeder tank hose to the master cylinder reservoir. Install a drain tube on the booster bleeder screw. Submerge the opposite end of the tube in a container par-

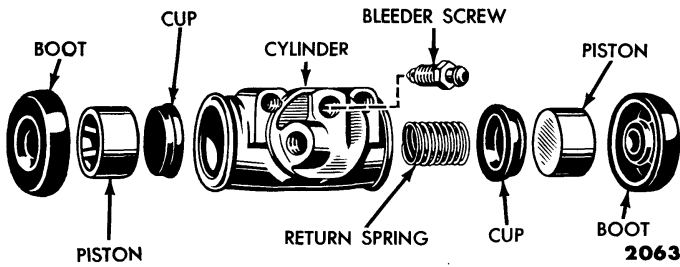

Fig. 5—Wheel Cylinder

tially filled with clean fluid, then open the bleeder screw. Open the valve on the bleeder tank to admit pressurized fluid to the master cylinder reservoir. Observe the flow of fluid to the master cylinder reservoir. Observe the flow of fluid from the drain tube. When air bubbles cease to appear in the fluid stream, close the booster bleeder screw and remove the tube. Repeat the operation at each wheel.

When the bleeding operation is completed, refill the master cylinder.

c. Wheel Cylinders.

The wheel cylinders are mounted on the brake carrier plates. Each wheel cylinder (fig. 5) contains two pistons, two rubber brake cylinder cups, a bleeder screw, and a piston return spring between the cups. Each end of each wheel cylinder is sealed by a rubber brake cylinder boot.

The front wheel cylinders have a larger diameter than the rear wheel cylinders to provide a higher braking ratio on the front wheels than on the rear. Therefore, the front and rear wheel cylinders are not interchangeable.

(1) **REMOVAL.** Disconnect the brake hose (front) or brake pipe (rear) from the wheel cylinder. Remove the wheel and drum. Install a wheel cylinder clamp or wire the wheel cylinder boots to the cylinder body. Re-

move the brake shoe retracting springs with the tool shown in fig. 11. Remove the wheel cylinder from the brake carrier plate. Remove the wheel cylinder clamp or wire from the cylinder.

(2) **DISASSEMBLY AND INSPECTION.** Remove the wheel cylinder to brake shoe links from the cylinder boots.

Remove the rubber brake cylinder boots from the wheel cylinder housing, then remove the pistons, cups, and piston return spring from the housing (fig. 5).

Thread the bleeder screw out of the housing.

Clean all parts of the wheel cylinder in clean brake fluid. Do not use kerosene or gasoline as a cleaner.

Inspect the cylinder bore for rust, scores, or other damage and replace the cylinder if necessary. Inspect the pistons, piston cups, and cylinder boots for wear, deterioration, incorrect size (growth), rough edges, and damage. Replace all parts that are not in good condition. Check the passage in the bleeder screw to make sure it is clean and open. Wheel cylinder repair kits are available which contain the piston cups and boots needed to rebuild two wheel cylinders.

(3) **ASSEMBLY.** Coat all wheel cylinder parts with clean brake fluid before installation in the cylinder. Place the pistons, cups, and return spring in the cylinder bore, then install the boots. For the correct position of the wheel cylinder parts, refer to fig. 5. Thread the bleeder screw into the wheel cylinder housing. Install the wheel cylinder to brake shoe links in the cylinder boots, then install a wheel cylinder clamp, or wire the boots to the cylinder.

(4) **INSTALLATION.** Install the wheel cylinder on the brake carrier plate. Position the webs of the brake shoes in the slots in the wheel cylinder to brake shoe links, then install the brake shoe retracting springs with the tool shown in fig. 12. Remove the wheel cylinder clamp or wire, then install the brake drum and the wheel. Connect the brake hose (front) or brake pipe (rear) to the wheel cylinder, then adjust and bleed the brakes.

d. Master Cylinder.

The master cylinder (fig. 6) is mounted on the dash panel in the engine compartment. The function of the master cylinder is to maintain a constant volume of brake fluid in the system at all times, and to convert physical pressure on the brake pedal to hydraulic pressure on the wheel cylinder pistons.

Construction details of the master cylinder used in conventional cars are shown in fig. 7. The Thunderbird master cylinder differs only in the design of the body.

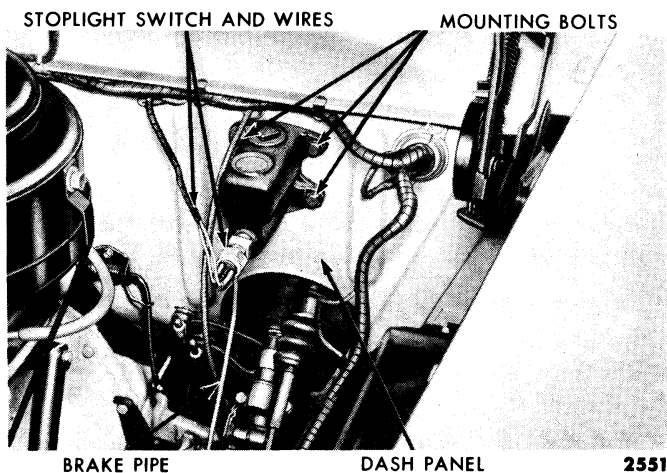

Fig. 6—Typical Master Cylinder Installation

The piston is equipped with a rubber cup at the push rod end. The brake master cylinder primary cup is held against the piston by the piston return spring and retainer. A check valve is used at the output end of the master cylinder to control the return flow of the hydraulic fluid from the wheel cylinders.

The master cylinder push rod seats in a depression in the piston, thus transferring movement of the brake pedal to the piston. The piston end of the master cylinder is sealed with a flexible rubber boot.

(1) **REMOVAL.** Disconnect the wires at the stop light switch, then remove the stop light switch. Disconnect the brake line (fig. 6) from the master cylinder, and depress the brake pedal a few times to force all the fluid from the master cylinder. Remove the eccentric bolt which attaches the master cylinder push rod to the brake pedal. Remove the master cylinder from the dash panel.

(2) **DISSASSEMBLY.** Clean all dirt from the outside of the cylinder assembly, then remove the filler cap and gasket. Remove the rubber boot and the push rod from the cylinder bore. Remove the stop light switch adapter, the brake pipe connector, and the gaskets from the master cylinder. Remove the snap ring, then pull the stop plate, piston assembly, primary cup, piston return spring, check valve, and valve seat out of the cylinder bore (fig. 7).

Clean all parts in clean brake fluid. Make sure the by-pass port, intake port, and the air vent in the filler cap are open. Inspect the cylinder walls for scores or rust and recondition if required. Do not hone beyond the allowable limit (0.003 inch) or any more than necessary to remove scores or rust and obtain a smooth cylinder wall, since oversize pistons and cups are not available. Be sure to remove any burrs caused by honing from the by-pass port and intake ports.

(3) **ASSEMBLY.** Dip all internal parts of the master cylinder in hydraulic brake fluid. Install the adapter and gaskets on the front end of the master cylinder. Position the valve seat, check valve, piston return spring, primary cup, piston, and stop plate in the cylinder bore (fig. 7). Secure the parts in the bore with the snap ring. Install the master cylinder boot on the push rod, then position the push rod in the cylinder with the boot over the end of the cylinder.

(4) **INSTALLATION.** Install the master cylinder on the dash panel (fig. 6). Tighten the screws to 12-18 foot-pounds torque. Position the master cylinder push rod on the brake pedal, then install the eccentric bolt and bushings. Adjust the brake pedal free travel, then tighten the bolt to 25-30 foot-pounds torque. Install the stop light switch, then connect the stop light switch wires to the switch terminals. Connect the brake line

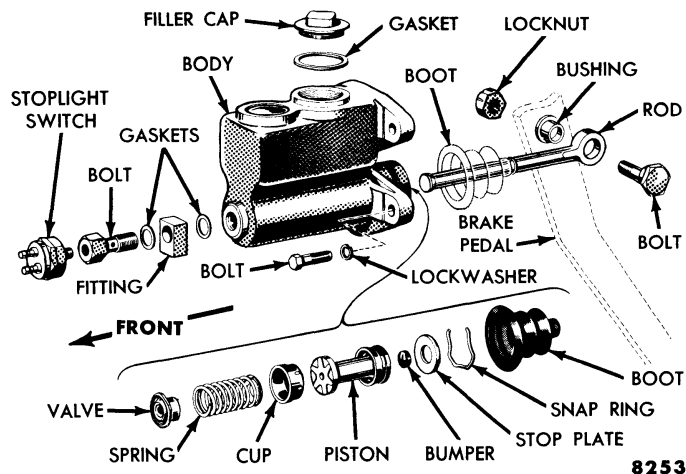

Fig. 7—Brake Master Cylinder—Conventional Cars

to the master cylinder, fill the cylinder with heavy-duty brake fluid, then bleed the brakes.

e. Hydraulic Pipe or Hose Replacement.

Hydrogen-welded steel pipe is used between the master cylinder and the frame connections, and between the rear axle tee fitting and the rear wheel cylinders. Flexible hose connects the brake pipe to the front wheel cylinders and to the rear axle fitting. When replacing hydraulic pipe or hoses, use new gaskets, and tighten all connections securely.

(1) **BRAKE PIPE.** If a section of the brake pipe becomes damaged, the pipe should be replaced with pipe of the same quality, shape, and length. Copper tubing is not satisfactory for use as brake pipe in a hydraulic system.

All brake pipe should be flared properly to ensure leak-proof connections. The two-stage flaring method, shown in fig. 8, must be used.

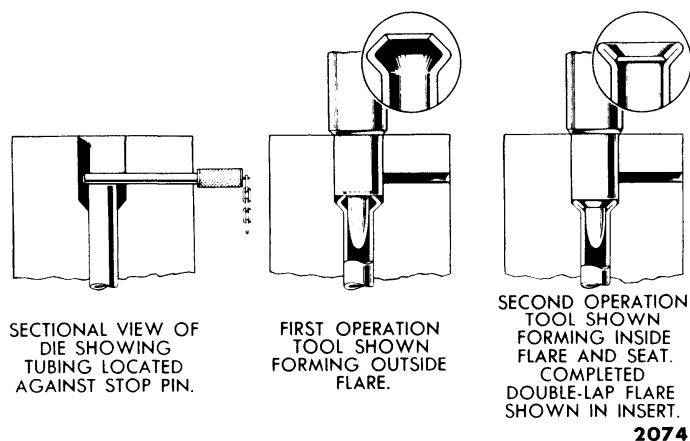

Fig. 8—Brake Pipe Flaring

(2) **BRAKE HOSE.** The flexible brake hose should be replaced if the hose shows signs of softening, cracking, or is damaged.

When installing new front brake hose, position the

hose so as to avoid contact with other chassis units. When installing new rear brake hose on cars equipped with the 6-cylinder engine or a dual exhaust system, make sure the hose is positioned so it does not contact the muffler tail pipe.

4. BRAKE ASSEMBLIES

Each front and rear brake assembly contains two shoes mounted on the brake carrier plate. The front shoe is the primary shoe and the rear shoe is the secondary shoe. The upper ends of the shoes are held against the anchor pin by individual return springs.

Each shoe is held against the carrier plate by a hold-down spring pin, a spring, and two cups. A brake adjusting screw assembly and a spring are used at the bottom to hold the shoes in the correct position in relation to each other.

The entire front brake assembly is rotated 10 degrees from the vertical position (fig. 2) to provide access to the bleeder screw.

Disassembled views of the front and rear brake assemblies are shown in figs. 9 and 10.

a. Removal and Disassembly.

Remove the wheel and drum, then install a wheel cylinder clamp or wire the wheel cylinder boots to the cylinder body. Disconnect the brake shoe retracting springs with the tool shown in fig. 11. Remove the anchor pin plate, then remove the brake shoe hold-down cups, pins, and springs.

On the rear brake only, disconnect the parking brake

cable at the parking brake lever (fig. 10), then remove the retainer and washer which secure the lever to the secondary brake shoe. Remove the lever, the link, and the link spring.

Lift the brake shoes and adjusting screw from the plate as an assembly. Move the anchor pin ends of the brake shoes toward each other, then remove the adjusting screw and spring.

CAUTION: Do not depress the brake pedal while the brake drum is removed.

b. Cleaning and Inspection.

Clean all parts except the lining and shoe assemblies in cleaning fluid. Remove dirt and corrosion from the brake carrier plate. After cleaning, dry the parts thoroughly with air or a clean cloth.

Inspect all parts for distortion and excessive wear. Replace worn or distorted parts. Check the operation of the adjusting screw. If the screw does not operate freely, remove the screw from the socket and nut and clean all parts. Apply Lubriplate, or its equivalent, to the threaded end of the screw, then install the screw in the nut and socket.

Inspect the condition of the brake lining. If it is worn to within $\frac{1}{32}$ inch of any rivet head, install new lining. Tighten any loose rivets.

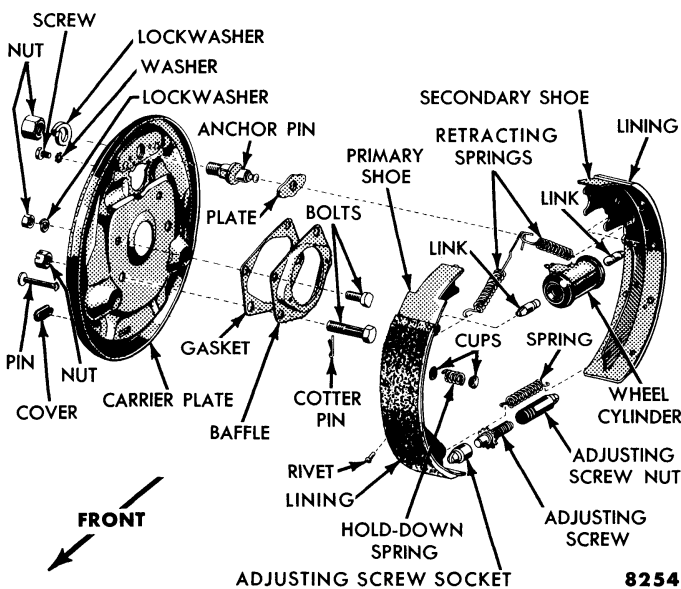

Fig. 9—Front Brake Assembly

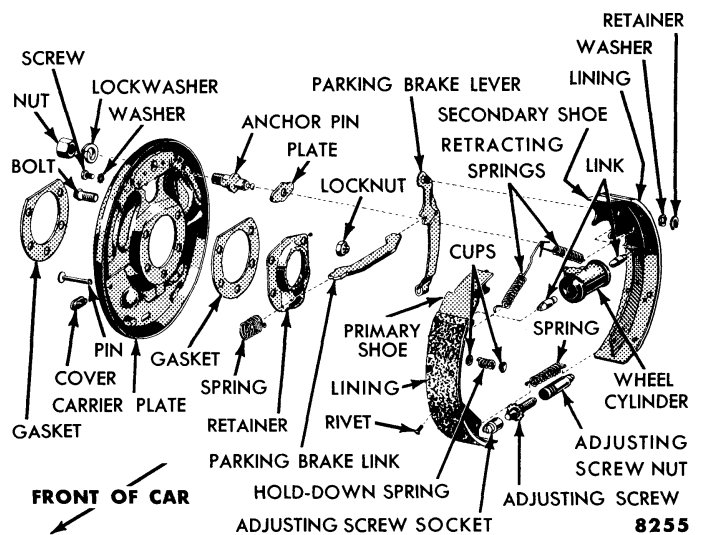

Fig. 10—Rear Brake Assembly

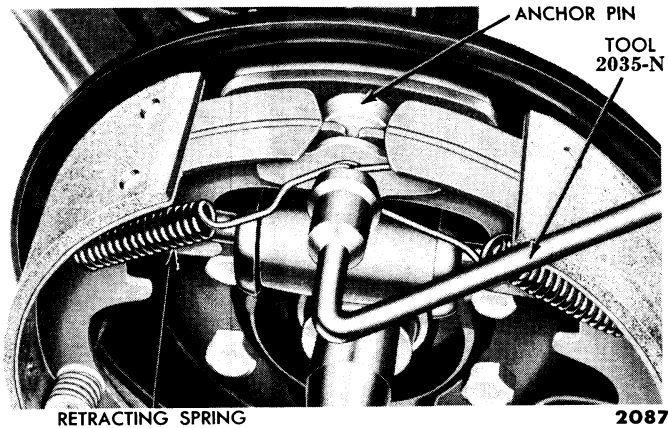

Fig. 11—Brake Shoe Retracting Spring Removal

c. Assembly and Installation.

Apply Lubriplate, or its equivalent, to all points of contact between the brake shoes and other parts. Do not permit the lubricant to get on the brake linings. Place the adjusting screw assembly between the brake shoes with the wheel of the screw aligned with the slot in the brake carrier plate, then install the adjusting screw spring (fig. 9). Place the brake shoes on the carrier plate with the primary shoe toward the front and the upper ends of the brake shoes properly positioned on the anchor pin and wheel cylinder links. Install the brake shoe hold-down pins, springs, and cups.

On the rear brakes only, place the parking brake lever in position on the carrier plate. Position the parking brake lever to primary shoe link on the lever, then install the link spring on the link. On the right-hand brake, install the spring with the small loop contacting the backing plate side of the shoe web. On the left-hand brakes, the spring loop must contact the outside face of the shoe web. Install the washer and retainer which secure the parking brake lever to the secondary brake shoe. Connect the parking brake cable to the lever.

Place the anchor pin plate on the anchor pin, then install the brake shoe retracting springs with the tool shown in fig. 12.

NOTE: *On all brakes, the primary shoe retracting spring must be installed first.*

Remove the wheel cylinder clamp or wire, then install the brake drum and wheel. Adjust the brakes.

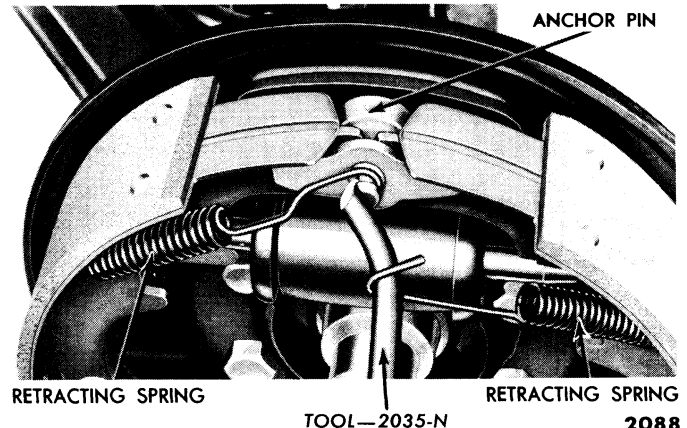

Fig. 12—Brake Shoe Retracting Spring Installation

d. Brake Shoe Relining.

If the distance from the surface of the lining to the rivet head is less than $\frac{1}{32}$ inch, the shoes should be relined. Failure to replace lining when this condition exists may cause severe damage to the brake drums. Brake shoes should be inspected for distortion and for looseness between the rim and web. If any of these conditions exist, discard the shoe. If shoes are serviceable, reline the shoes as follows:

Remove the old rivets, then remove the old lining. Thoroughly clean the surface of the shoe rim and remove any burrs or high spots. Each Ford brake lining kit contains primary and secondary linings, and the necessary rivets. These linings are ground in production and do not require grinding after installation.

Position the new lining on the shoe, then install the two center rivets. Install the remaining rivets, working from the center to the ends of the shoe.

NOTE: *Do not permit oil or grease to come in contact with the lining.*

After all rivets are installed, check the lining to shoe clearance. The lining must seat snugly against the shoe with no more than 0.005 inch separation midway between rivets.

NOTE: *Whenever new linings are installed, caution the car owner to avoid fast stops wherever possible until the car has been driven at least 100 miles. The importance of properly seating the linings before severe application is required of them cannot be overstressed.*

5. BRAKE DRUMS

The front brake drums are staked to the front hubs, and the hub and drum is serviced as an assembly. The rear drums are of the demountable type, and are secured

to the axle shaft flanges with spring nuts which are installed on the hub bolts.

Brake drums that are rough, scored, or out-of-round

should be rebored to provide a smooth drum surface. If the drums are rebored to less than 0.030 inch oversize on the diameter, standard linings may be installed. If the drums are rebored to 0.030–0.060 inch oversize on the diameter, a 0.030 inch thicker lining must be used

as a replacement.

NOTE: *Do not remove more than 0.030 inch of material when reboring brake drums (0.060 inch on the diameter).*

6. VACUUM BOOSTER

Power braking is provided by a vacuum booster assembly installed in the standard hydraulic system. Figure 13 shows a typical vacuum booster installation in the car engine compartment.

a. Construction.

The vacuum booster (fig. 14) consists of a vacuum power chamber, a hydraulically-operated vacuum control valve, and a hydraulic slave cylinder, all in a single unit.

A spring-loaded, disc-type vacuum check valve is installed in the system for the purpose of maintaining maximum vacuum in the system.

The power or booster chamber contains a rubber diaphragm and a metal pressure plate assembly. The outer bead of the rubber diaphragm acts as a support for the diaphragm and as a seal between the two halves of the booster chamber. A push rod, attached to the pressure plate, extends through a bushing and seals, and into the slave cylinder.

A by-pass tube connects to the control valve.

The rear body supports the slave cylinder and control valve. A hose, connected to the booster check valve and to the intake manifold, provides a means to exhaust air from both halves of the chamber, thus creating a

vacuum. A diaphragm return spring assists in brake release.

The control valve, mounted on the slave cylinder, is hydraulically connected to the slave cylinder by an internal passageway. The atmospheric intake and air cleaner is located on the control valve housing.

The hydraulic fluid inlet from the master cylinder is at the front end of the slave cylinder, and the outlet to the wheel cylinder is near the rear end of the slave cylinder. A bleeder screw is provided in the slave cylinder to permit bleeding the hydraulic system.

b. Operation.

When the engine is running and the brakes are released, vacuum on both sides of the diaphragm and pressure plate assembly (fig. 14) permits the return spring to hold the diaphragm and pressure plate assembly in the released position. Under these conditions, a normal residual pressure is maintained in the hydraulic lines.

When the brake pedal is depressed, fluid passes from the master cylinder through the slave cylinder piston openings to the control valve plunger and piston, around the slave cylinder piston check valve, and through the piston and cup orifices into the brake lines. As the hydraulic line pressure builds up, the control valve plunger and piston moves out and seals the vacuum in the rear

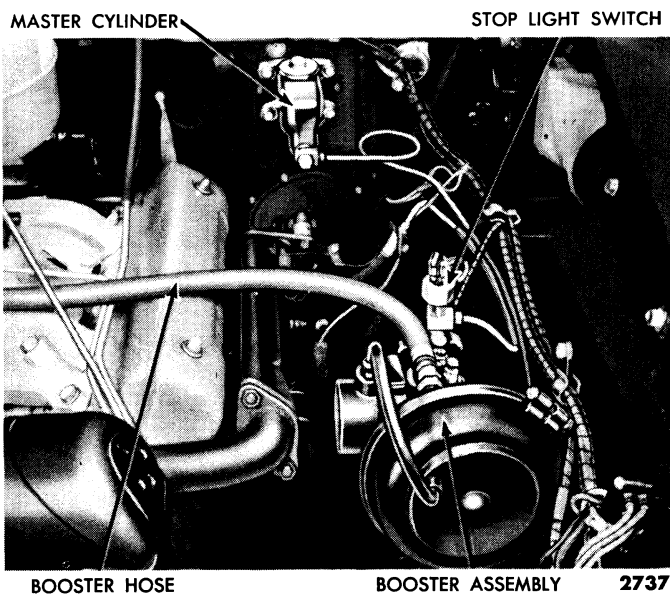

Fig. 13—Vacuum Booster Installation

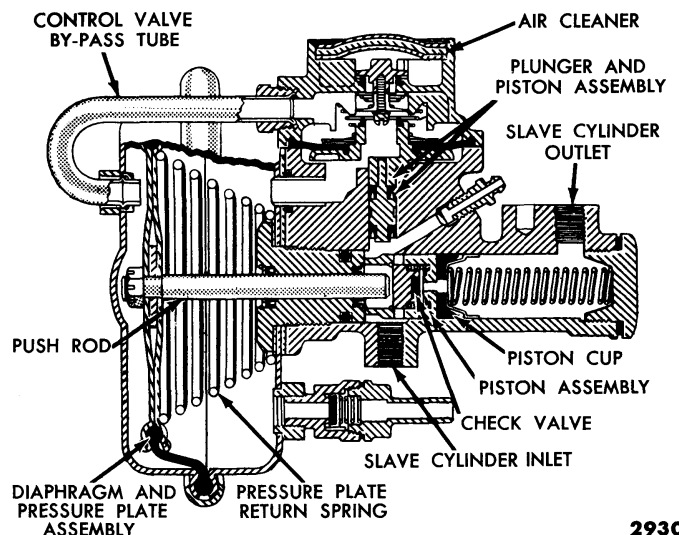

Fig. 14—Vacuum Booster—Sectional View

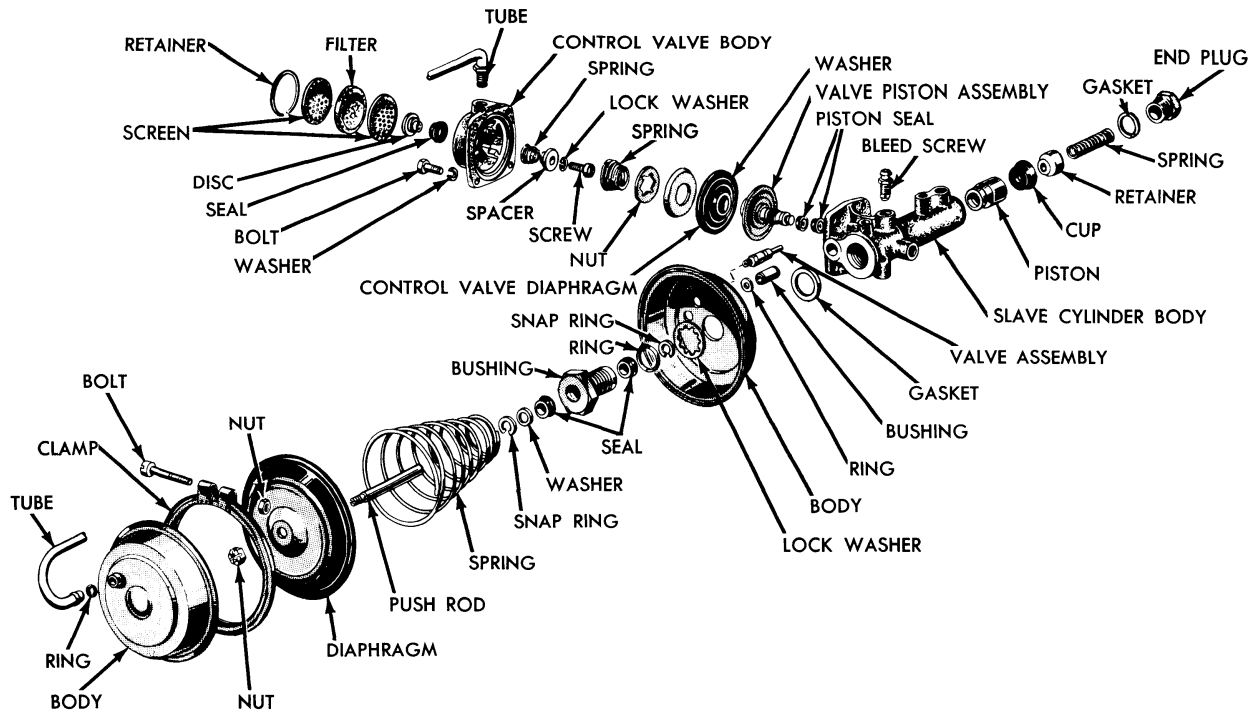

Fig. 15—Vacuum Booster—Disassembled

2495

section of the power chamber. The atmospheric pressure in the front section forces the diaphragm and pressure plate assembly and the push rod back toward the slave cylinder. This movement causes the check valve to seal the brake fluid in the slave cylinder and brake lines. As the push rod continues to move back, the slave cylinder piston and cup also moves back and builds up the hydraulic line pressure to operate the brakes.

If the power chamber fails to operate when the brake pedal is depressed, the hydraulic system will continue to function. The brake fluid will by-pass through the slave cylinder piston openings and the piston and cup orifices so that brakes will be applied directly by the master cylinder. However, greater pedal pressure is required when the vacuum booster is not operating.

c. Booster Repair.

The following service procedures are for the complete overhaul of the vacuum booster.

(1) **REMOVAL.** Depress the brake pedal several times to remove all vacuum from the system. Disconnect the hydraulic lines and the vacuum hose at the booster. Disconnect the stop light switch wires at the switch, then remove the booster from the mounting bracket.

(2) **DISASSEMBLY.** Remove the control valve by-pass tube from the booster assembly (fig. 15). Remove the control valve body, diaphragm spring, and the control valve piston and diaphragm assembly from the slave cylinder body.

Mark both bodies of the booster chamber and the flanges of the control valve and the slave cylinder so they can be assembled in their original positions. Remove the clamp ring, the outer section of the booster chamber, and the diaphragm and pressure plate assembly with the return spring.

Remove the push rod bushing and the inner section of the power chamber from the slave cylinder. Remove the end plug from the slave cylinder, and remove the gasket, piston spring, and retainer (fig. 15). Remove the slave cylinder piston and the rubber piston cup from the slave cylinder.

Remove the inner and outer seals from the control valve shaft. Remove the control valve disc seal from the diaphragm assembly. Remove the snap ring that holds the air cleaner in the control valve body, and remove the air cleaner screens and filter. Remove the screw and lock washer that hold the control valve disc in place, then remove the disc, seal, spacer, and spring from the control valve body.

Remove the seal from the inner end of the push rod bushing, then remove the outer seal. Remove the seal from the slave cylinder and plug. Remove the check valve and spring from the slave cylinder piston.

Remove the push rod from the diaphragm. Remove the booster check valve from the fitting.

(3) **INSPECTION.** Wash all metal parts in brake fluid. Wipe them thoroughly with clean rags, and use compressed air to dry all internal passages.

Replace all worn or damaged parts. Ford repair kits, which contain the parts most likely to need replacement, are available. If, upon examination, there are signs of wear or corrosion in the control valve plunger or slave cylinder bores, the slave cylinder body should be replaced.

The push rod must be perfectly smooth and must show no wear to avoid leakage at the seal. It should be replaced if it is rough or damaged. Replace the control valve diaphragm, all rubber cups and seals, and the spring. If the control valve seat is damaged, replace the control valve body.

Clean the air cleaner screens, and blow them dry with compressed air.

(4) **ASSEMBLY.** Install the check valve in the fitting (fig. 15). Position the diaphragm on the control valve. Position the retaining plate and install the clip on the control valve diaphragm. Install the inner and outer seals on the control valve shaft. Install the control valve disc seal in the control valve housing. Install the valve disc, spacer, and spring in the control valve housing, then tighten the fastening screw.

Install the air cleaner screens, filter, and snap ring to the control valve housing. Install the inner and outer seals on the push rod bushing. Install the push rod on the diaphragm pressure plate and secure with the nut. Install the spring and valve in the slave piston. Install

the snap ring in the slave piston.

Install a new gasket on the power chamber inner body. Position the inner body on the slave cylinder, then install the push rod bushing, through the body, on the slave cylinder. Install a new seal in the end of the push rod bushing. Position the seal retainer, and install the snap ring in the end of the push rod bushing. Position the pressure plate return spring in the inner body. Position the push rod and diaphragm assembly on top of the return spring and in the push rod bushing. Place the outer body on top of the diaphragm assembly. Position the power chamber clamp and tighten the clamp screw. Position the slave piston cup in the slave cylinder. Install the spring retainer cap and the slave piston return spring. Install and tighten the end plug in the slave cylinder. Position the control valve on the slave cylinder body. Position the control valve body to the slave cylinder, and install the bolts and lock washers. Install the check valve on the power chamber rear body. Install the by-pass tube on the power chamber and the control valve body.

(5) **INSTALLATION.** Install the booster assembly on the mounting bracket. Connect the stop light wires to the stop light switch. Bleed the air from the brake system. Connect the booster hose to the booster, and tighten the hose clamps securely. Connect the hydraulic lines to the booster.

7. PARKING BRAKES

The rear brake shoes are used as parking brakes, and are operated by a cable-controlled linkage which is independent of the hydraulic system.

A flexible cable connects the parking brake control handle with the parking brake equalizer lever. The equalizer lever is mounted in a bracket on the frame cross member, and is connected with the equalizer yoke through an adjustable rod.

A continuous flexible cable extends from the parking brake lever in the right-hand brake assembly, through the equalizer yoke, then to the parking brake lever in the left-hand brake assembly. The cable is held in position in each brake carrier plate by a pronged, bell-shaped, spring clip.

The upper end of each parking brake lever is pinned to the web of each secondary brake shoe. A parking brake lever to primary shoe link is installed between each lever and each primary shoe. As a result, both brake shoes are actuated when the parking brakes are applied.

a. Adjustment.

The rear service brakes should be adjusted before the parking brake cables are adjusted. In most cases, this

adjustment will also provide satisfactory parking brake action. If the parking brake cables need adjusting, proceed as follows:

Make sure the service brakes are fully released, then place the parking brake control handle in the fully-applied position. Check the position of the parking brake equalizer lever with respect to the frame cross member. If the lever is touching the frame cross member, the control handle to equalizer lever cable must be adjusted.

Place the parking brake control handle in the fully-released position, then rotate the equalizer lever nut to adjust the length of the cable. Apply the parking brakes and check the adjustment.

If there is slack in the parking brake cables when the parking brake control handle is in the fully-released position, adjust the parking brake cables as follows:

Loosen the lock nut on the equalizer rod, then tighten the adjusting nut just enough to remove the slack from the cables. Pull the cables alternately to equalize the tension on each through the yoke. Tighten the lock nut securely.

CAUTION: *Do not tighten the cables too much as the rear brake shoes will be pulled off their anchors.*

Part THREE

ELECTRICAL AND ACCESSORIES

Chapter I

Generating System and Battery

Section	Page
1 Trouble Shooting	217
2 Generator	221
3 Generator Regulator	226
4 Battery	232

The generating system consists of three principle units: the generator which converts mechanical energy to the electrical energy used for ignition, lights, and various accessories; the regulator which controls generator output according to needs; and the battery which stores electrical power for starting the engine and for operating electrical units when the generator is not delivering sufficient output.

Schematic wiring diagrams (figs. 1 and 2) of the generating circuit show the internal connections and windings of the various units. Color codes are shown to aid in tracing the circuit. Wire sizes are given as a guide for replacing any of the wires in the circuit.

Since the generator and generator regulator are precision built units, they must be checked with accurately calibrated instruments. Correct regulator setting requires that voltmeters be accurate to 0.05 (1/2 of one tenth) volt within the ranges of 13 to 16 volts, and that ammeters be accurate to 1 ampere between 30 and 40 amperes and between 50 and 60 amperes. All meters

should be calibrated once a year and the date of calibration should be stamped on the meter face.

Certain tests outlined in this section are illustrated both in the form of an electrical schematic and a pictorial drawing. The schematic shows the complete electrical circuit. The pictorial drawing illustrates typical test equipment connections. In some test equipment, the necessary instruments and controls are combined in a single unit. Since these units are connected according to the particular make, be sure to follow the directions of the manufacturer when using such combined equipment.

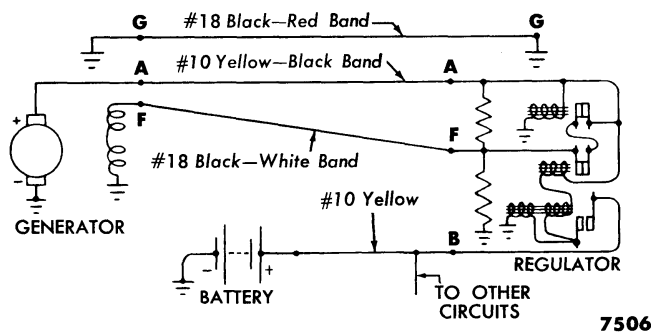

Fig. 1—Generating System Circuit—Schematic

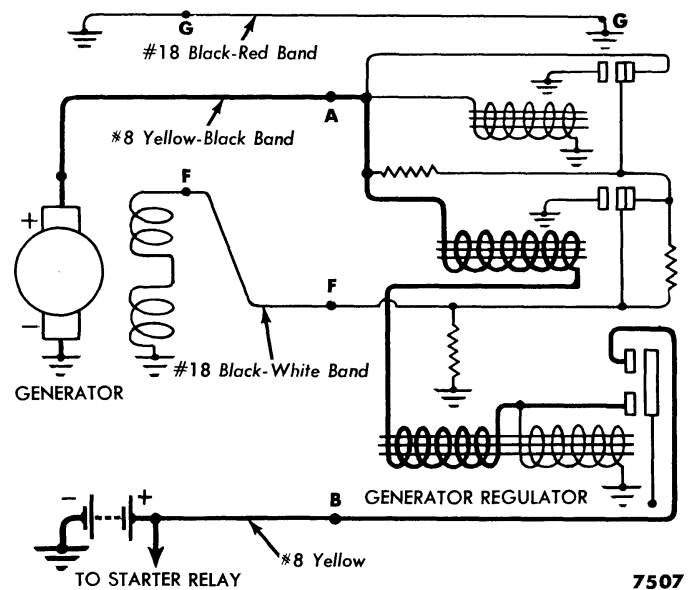

Fig. 2—Generating System Circuit—Bosch Built Heavy Duty Regulator

I. TROUBLE SHOOTING

Possible causes of trouble in the generating system reveal themselves in one of three major "symptoms." Either the battery has failed or is low in charge, the generator output is too low, or the charging rate is too

high. First determine the correct symptom by testing or by analyzing. Once you have confirmed the symptom you can immediately begin to isolate the cause by following the "road map" that illustrates the procedure in

outline form.

Table 1 lists the three symptoms and the various causes of trouble. The order of the numbers, in each symptom column, indicates either the most probable cause of the symptom or the cause which is easiest to eliminate by testing.

The trouble shooting table gives a list of the possible troubles for each symptom. The "road map" of each symptom combines, into one test, all the procedures necessary for determining which particular trouble is causing that symptom. You begin the "road map" by following the test procedures as indicated by the black dots. The results of these tests will lead you to one of the squares which will, in turn, guide you on down the "road map" to further test procedures, adjustments, or repair operations. Your journey will eventually terminate either at a star, which indicates that you have eliminated the trouble, or a direction to follow the "road map" of a different symptom.

For a clearer understanding of the trouble shooting procedure, be sure to follow the "road map" and the trouble shooting write-up concurrently. To this end, the letters and numbers in the body of the "road map" refer to headings in the trouble shooting write-up. The symptoms are used as headings for the procedures which are outlined in the following paragraphs:

a. Battery Low in Charge.

Indications of a battery low in charge are slow cranking, hard starting, and headlights dim at engine idle speed. Causes are: the generator belt worn, or loose and slipping over the generator pulley; the battery in such poor condition that it will not hold or take a charge; the generator not producing its rated output; regulator units out of adjustment, and excessive resistance in the generator-to-battery circuit or in the battery-to-ground circuit.

Before attempting further repairs, check the state of charge of the battery. Also check the generator belt adjustment and condition. If the belt is badly worn or too loose, a new belt or a belt adjustment might be needed.

Table 1—Generating System Causes of Trouble

CAUSES	Symptoms		
	a.	b.	c.
	Battery Low in Charge	Generator Output Low	High Charging Rate
Loose Generator Belt	1		
Battery Worn Out	2		
Defective Generator	3	1	
Improperly Operating Regulator	4		1
Excessive Resistance in Charging Circuit	5		

Figure 3 indicates the Battery Low in Charge "Road Map."

(1) **RECHARGE OR REPLACE BATTERY.** Make a "Battery Capacity Test." If the battery tests good, recharge the battery. If the battery does not test good, make a "Battery Test Charge." Replace the battery if the test indicates it is worn out or under capacity. If the battery is worn out, it may have been the cause of the "Battery Low" symptom. If the battery tests OK, proceed as follows:

(2) **CHECK GENERATOR OUTPUT.** Test the generator output to determine if the generator is at fault. If the output reaches or is greater than the rating of the generator for the generator under test, proceed with (b) below. If the output is less than rated amperes, follow

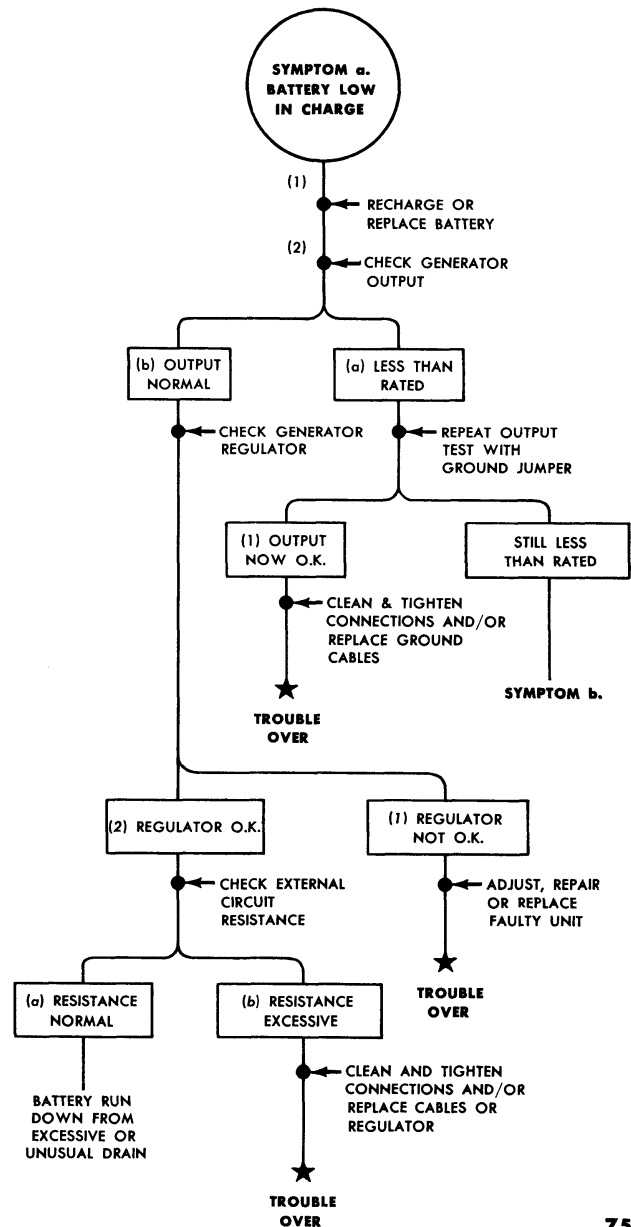

Fig. 3—Battery Low in Charge—"Road Map"

the procedures outlined in (a) below.

(a) **OUTPUT LESS THAN RATED.** If the current output of the generator does not reach the rated output, connect a heavy jumper wire from the battery ground post to the generator ground terminal. Repeat the generator output test. If the output now reaches or exceeds rated output, follow the procedure in (1) below. If the output is still less than rated, the generator is at fault. Refer to symptom "b. Generator Output Low."

(1) **OUTPUT NOW OK.** If the output now reaches or exceeds rated output, either the generator or the battery is not properly grounded to the engine frame. Replace the battery-to-ground cable if it is corroded or partially broken. Clean the cable connections at the battery and engine, and tighten the connections. Tighten the generator and generator mounting bracket bolts. The trouble should now be over as indicated by the star on the "road map."

(b) **OUTPUT NORMAL.** If the generator output is normal, test the regulator to determine if it is properly adjusted. If the regulator is not OK, follow the procedure in (1) below. If the regulator checks OK, follow the procedure in (2) below.

(1) **REGULATOR NOT OK.** After checking all three regulator units, adjust, repair, or replace the regulator as necessary. These operations should bring you to the "Trouble Over" star on the "road map."

(2) **REGULATOR OK.** Check the external circuit to determine if it has excessive resistance. If the resistance is normal, proceed as in (a) below.

(a) **Resistance Normal.** If the resistance (voltage drop) is equal to or less than that specified for the vehicle, the battery is low in charge due to improper operation by the owner. Excessive night driving or use of accessories, insufficient operation of vehicle, accidental discharge of battery (lights, ignition, radio, etc., left on overnight), improper starting procedure (flooding engine, not using choke properly, etc.), or too heavy a grade of engine oil for the local climate, could take more current from the battery than the generator can replace. Instruct the owner in proper operation of his vehicle.

(b) **Resistance Excessive.** If the resistance (voltage drop) is greater than that specified for the vehicle, locate the exact part of the circuit with the excessive resistance and follow (1), (2), (3), or (4) below.

(1) If the resistance is in the generator-to-regulator circuit, clean and tighten the cable connections. Recheck the voltage drop. If it is still excessive, replace the cable.

(2) If the resistance is in the regulator cut-out contact, disconnect a battery cable from the battery.

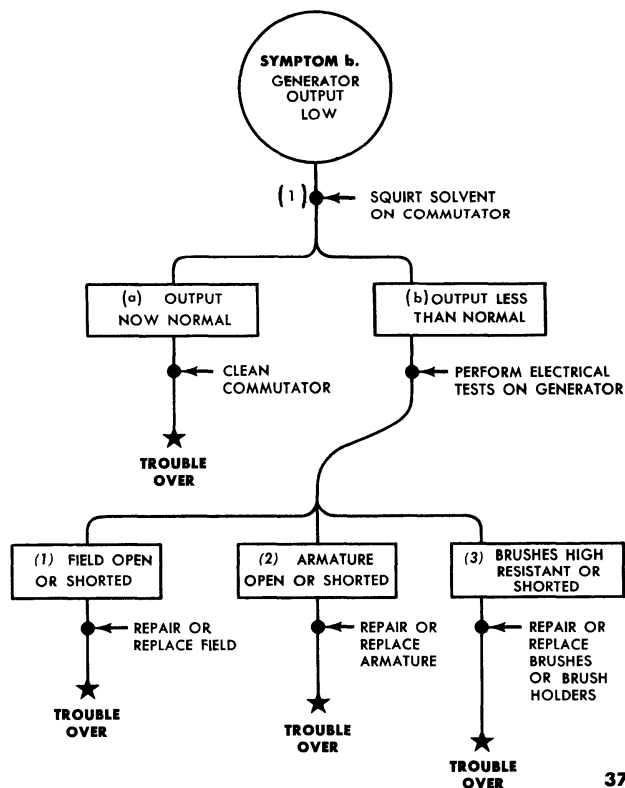

Fig. 4—Generator Output Low—"Road Map"

Remove the cover from the regulator. Remove oil and dirt from the cut-out contact surfaces by pulling a clean piece of bond paper or other lint-free substance between the contact surfaces while holding the contacts closed on the paper. On regulators which have been in service for some time, paper cannot be used to clean the contact surfaces, as they are rough and pitted and the paper may become torn. Examine all soldered connections to see that they are in good condition. Replace the battery cable and recheck the voltage drop. If it is still excessive, replace the regulator.

(3) If the resistance is in the regulator-to-battery circuit, clean and tighten the cable connections (regulator "BAT" terminal, battery terminal of starting relay, battery-to-starting-relay-cable connection on battery post). Examine all cables to see that they are in good condition. If the voltage drop is still excessive on recheck, check the connections at the battery terminal on the lighting switch to see that they are clean and tight. Replace the cables where necessary.

NOTE: Most of the trouble causing excessive resistance in the external circuit will be found in this portion of the circuit.

(4) If the resistance is in the battery-to-ground circuit, clean and tighten the cable connections. Recheck the voltage drop. If it is still excessive, replace the cable. The trouble should now be over.

- A**- CONNECT AMMETER TO FIELD TERMINAL (CONNECTIONS MARKED ①)
B- CURRENT SHOULD BE 1.4 TO 1.6 AMPERES AT 12 VOLTS. LOW CURRENT INDICATES POOR OR BROKEN CONNECTIONS. HIGH CURRENT INDICATES SHORTED COILS.
C- CONNECT AMMETER TO ARM TERMINAL (CONNECTIONS MARKED ②)
D- CURRENT SHOULD BE 30-40 AMPERES
E- IF CURRENT IS LOW, PRESS DOWN BRUSHES. IF CURRENT BECOMES NORMAL, BRUSHES ARE STICKING.
F- IF CURRENT IS HIGH, LIFT A BRUSH FROM COMMUTATOR. CURRENT SHOULD DROP TO ZERO. IF ANY CURRENT FLOWS WITH BRUSH LIFTED, BRUSH HOLDER IS GROUNDED.

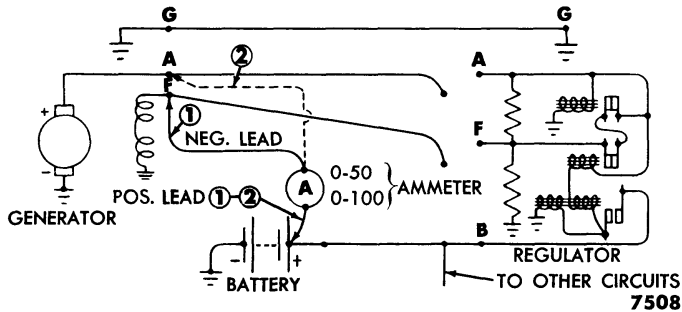

Fig. 5—Electrical Test of Generator—Diagram and Procedure

b. Generator Output Low.

This symptom usually is uncovered by the “generator output test” under “Battery Low In Charge” above. The generator output could be low due to a dirty commutator, open or short circuit in the field, armature, brushes, or brush holders, or the brushes can be worn too short or may be sticking in the brush holder and not making good contact on the commutator.

Figure 4 illustrates the Generator Output Low—“Road Map” which outlines the procedure by means of the various tests and conclusions drawn from the tests.

(1) **SQUIRT SOLVENT ON COMMUTATOR.** Squirt Carbon Tetrachloride on the commutator through the generator frame ventilating slots to determine if the commutator is oily or dirty. If dirt or oil is present, the Carbon Tetrachloride will momentarily dissolve the dirt or oil on the commutator and permit the brushes to make better electrical contact. Test the generator output. If the output is now normal, proceed with (a). If the output is still less than normal, proceed with (b).

(a) **OUTPUT NOW NORMAL.** If the output now reaches rated current, the commutator is oily or dirty. Remove the generator from the vehicle and disassemble it. Clean the commutator surface with fine sandpaper (not emery cloth or emery paper), and scrape out the slots between the commutator segments to remove dirt and carbon particles. If necessary turn down the commutator in a lathe and undercut the mica. Clean the brush holders and brushes. Reassemble the generator and install it. Adjust the generator belt tension.

(b) **OUTPUT STILL LESS THAN NORMAL.** If the output is still less than normal, perform the electrical tests of

the generator on the vehicle, as illustrated in fig. 5, to determine the exact part of the generator causing trouble. If the field checks short or open, follow (1). If the armature checks short or open, follow (2). If the brushes are making poor contact, or are shorted, follow (3).

(1) **FIELD OPEN OR SHORTED.** If the test shows the field has an open or short circuit, remove the generator, disassemble and repair it, if possible. If no repairs can be made, replace the field coils and reassemble the generator. Mount the generator on the engine, adjust the generator belt tension, and polarize the generator.

(2) **ARMATURE OPEN OR SHORTED.** If the armature test shows the armature circuit to have an open or short, remove the generator, disassemble and repair it, if possible. If the repair can not be made, replace the armature and reassemble the generator. Mount the generator and adjust the generator belt tension.

(3) **BRUSHES MAKING POOR CONTACT OR SHORTED.** If the brush inspection shows that the brushes are making poor contact, or are shorted to the end plate, frame, or field coil leads, remove the generator, disassemble and repair it, if possible. If the brushes are stuck in the holder, repair or replace the end plate and brushes. Replace the brushes if they are worn to less than one-half inch. If the negative brush holder is shorted to ground, repair the insulation if possible. If not, replace the end plate and reassemble the generator. Install the generator and adjust the belt tension.

c. High Charging Rate.

Indications of this symptom are: generator, lights, fuses, or radio tubes burn out prematurely; the battery requires too frequent refilling; and the ignition contacts are burned. The most common cause of these troubles is high voltage, and the first step in trouble shooting is to correct possible high voltage regulation. In cases where the generator itself burns out, in addition to the high voltage, a high setting of the current limiter could account for the failure.

(1) **CHECK VOLTAGE REGULATION.** Make certain that all connections, including the regulator ground, are tight. Check the voltage regulation. If the voltage regulation is high follow (2) below.

(2) **INSPECT AND ADJUST VOLTAGE REGULATOR.** Remove the regulator cover and depress the voltage regulator armature to see if the contacts are stuck and will not open. Check the contacts, and replace the regulator if the contacts are burned or oxidized.

If the points are not sticking and are in good condition, adjust the voltage regulation to the specified limits. Recheck the setting with the cover in place.

2. GENERATOR

The job of converting mechanical energy into electrical energy is done by revolving several windings of wire within a magnetic field. In the generator (fig. 6), these wires are wound in slots cut in iron laminations which are mounted on a shaft. The wires are connected, at one end of the shaft, to commutator segments which are insulated from each other. This unit, composed of shaft, iron laminations, windings and commutator segments, is called the armature. The magnetic field is formed by field coils wound around two soft iron pole shoes which are attached by screws to the generator housing. By revolving within this field, the armature produces a voltage at the terminals of each of its windings (commutator segments). The voltage thus generated is available to force current through the external circuits, whenever they are closed.

Stationary armature brushes, which are connected to the external electrical circuits, are held by springs against the revolving commutator segments. Thus, each time a segment contacts the brush, the voltage generated in each winding forces current through the brush and from the brush through any closed external circuit. From the various external circuits of the car, the current returns to the armature windings through the metal chassis and the generator armature ground brush.

The front end of the armature shaft is supported by a permanently-lubricated ball bearing which fits into the front end plate (fig. 6). The shaft is keyed to an integral pulley and cooling-fan assembly. The pulley is connected to the engine flywheel with a belt. Thus the armature receives its mechanical energy from the engine. The rear end of the 8-cylinder engine generator armature shaft is supported by a permanently lubricated ball bearing in the brush end plate. The rear bearing on the 6-cylinder engine generator shaft is a bronze bushing, and requires periodic lubrication.

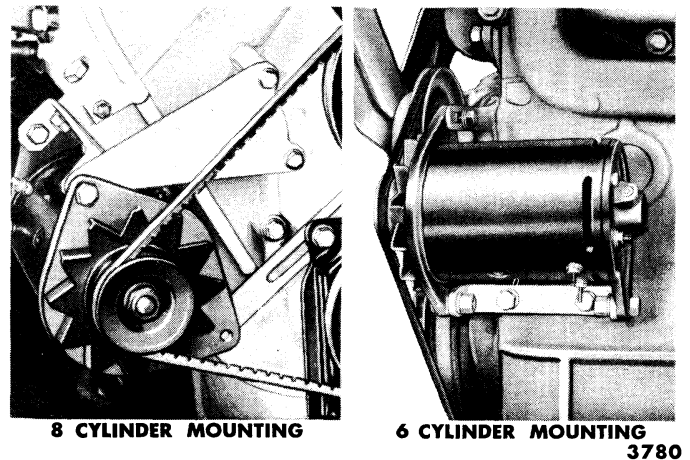

Fig. 7—Generator Mountings

NOTE: On some heavy duty 6-cylinder engine generators, the rear bearing is permanently lubricated.

Standard generators are shunt wound (armature and field circuits connected in parallel), two-brush, high output generators. The generating system is a negative (—) ground system. Output is controlled by a regulator which is connected between the armature and field. The field is grounded internally (figs. 1 and 2).

Generator mountings for the various engines are shown in fig. 7.

a. Generator Tests.

The necessary equipment used in the six generator tests outlined below is as follows:

- 0-5
 - 0-50 For Standard Generator
 - 0-100 For Heavy Duty Generator
 - 0-20 Voltmeter
 - "Growler" Tester
- } Ammeter

Storage battery, assorted connecting wires, and jumper wires equipped with suitable connectors.

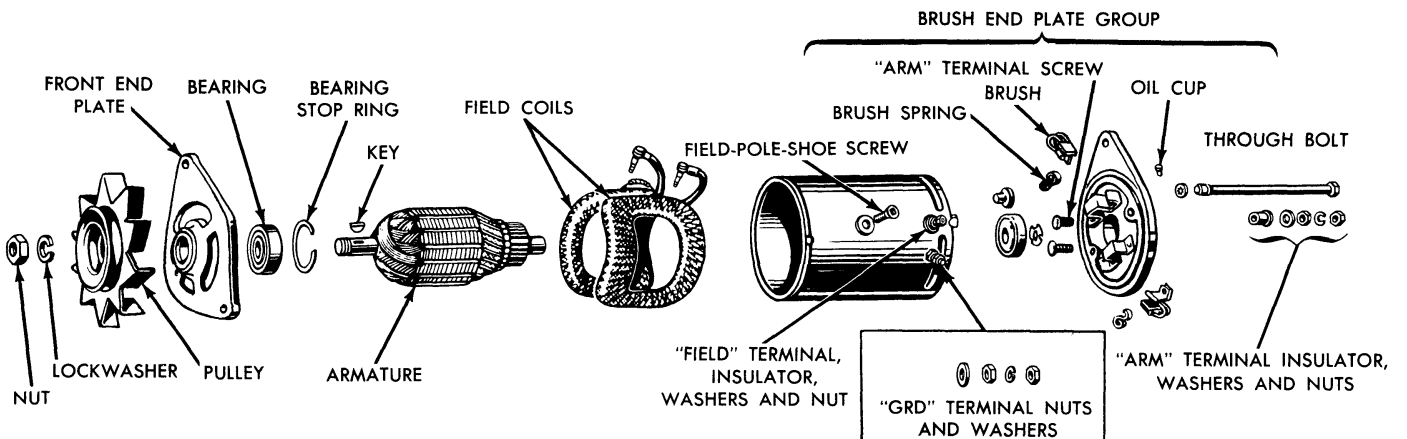

Fig. 6—Disassembled Generator—Typical

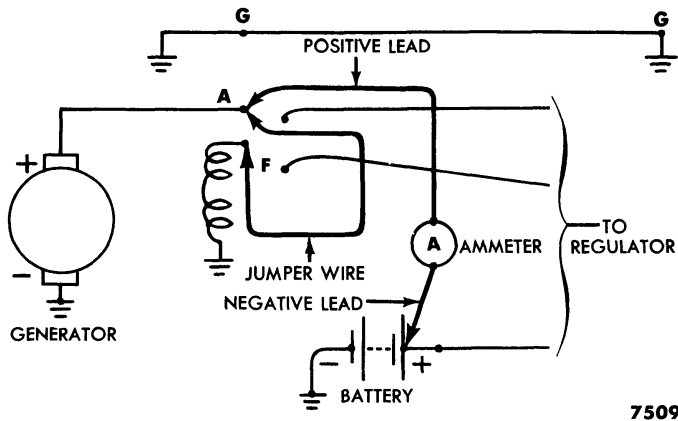

Fig. 8—Generator Output Test—Schematic

Various makes of generator and regulator test benches combine all the above listed items into one unit and are equipped with a motor drive. Such equipment can be used to facilitate the generator tests. When such combined equipment is used, be sure to follow the manufacturer's instructions.

Only two of the six generator tests outlined below, namely "Generator Output Test" and "Field Open or Short Circuit Test," can be made either on or off the vehicle. All other tests must be made off the vehicle only. Unless otherwise specified, all "off the vehicle" tests can be made either with a generator-regulator test bench or with the separate equipment as listed above.

The following procedures are for use with separate equipment:

(1) **GENERATOR OUTPUT TEST.** When a generator output test is conducted off the vehicle, a generator-regulator test bench must be used. In this case, the generator is placed on the test bench and driven by the motor. Follow the procedure given by the manufacturer.

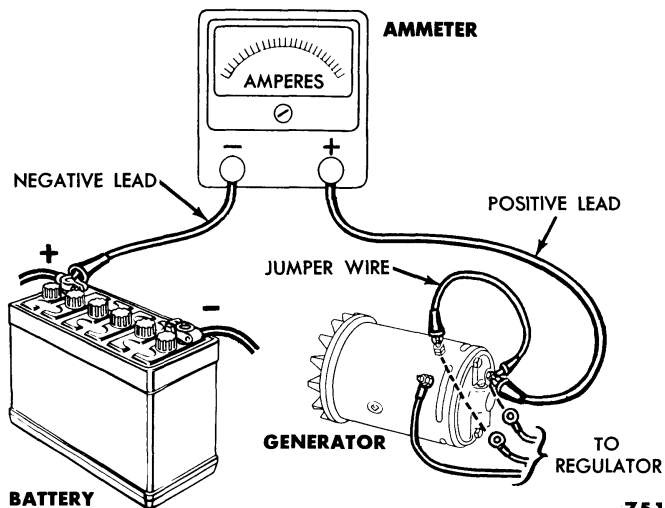

Fig. 9—Generator Output Test Connections

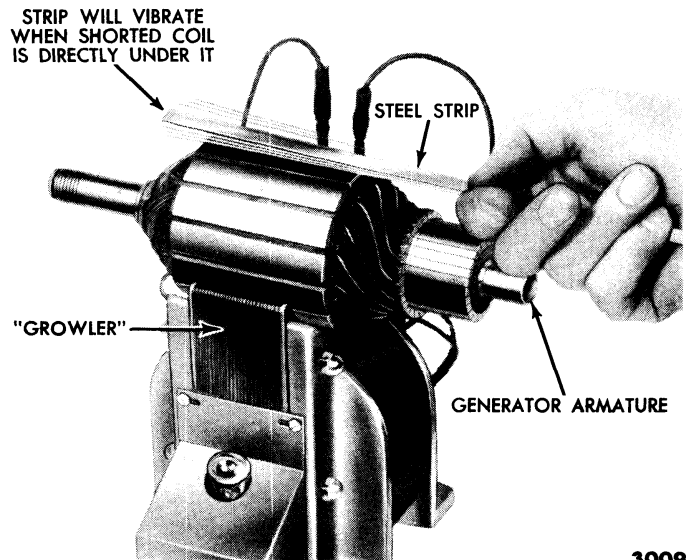

Fig. 10—Growler Test for Shorted Armature

To test the output of the generator on the vehicle, proceed as follows (see figs. 8 or 9):

Disconnect the regulator "ARM" and "FIELD" wires at the generator. Connect a jumper wire from the generator "ARM" terminal to the generator "FIELD" terminal and the positive lead of a 0-50 ammeter to the generator "ARM" terminal (use 0-100 ammeter on heavy duty systems). Start the engine and while idling connect the ammeter negative lead to the battery. Run the engine at 1500 r.p.m., and read the current output on the ammeter. The generator output should reach or exceed 30 amperes (40-60 amperes on the heavy duty generators).

NOTE: Stop the engine and disconnect the test leads as soon as the test is completed to prevent overheating the generator.

(2) **ARMATURE TESTS.** Checking the armature for open, short, or grounded circuit can be done "off the vehicle" only.

(a) **OPEN CIRCUIT TEST.** An open circuit in the armature can sometimes be detected by examining the commutator for evidence of burning. The spot burned on the commutator is caused by an arc formed every time the commutator segment connected to the open circuit passes under a brush.

(b) **SHORT CIRCUIT TEST.** To test the armature for a short circuit in the windings, a "growler" must be used as shown in fig. 10. Rotate the armature slowly. When the shorted winding is under the steel strip, it will cause the strip to vibrate.

(c) **GROUNDING CIRCUIT TEST.** To determine if the armature windings are grounded, make the connections as shown in fig. 11. If the voltmeter indicates any voltage, the armature windings are grounded to the frame.

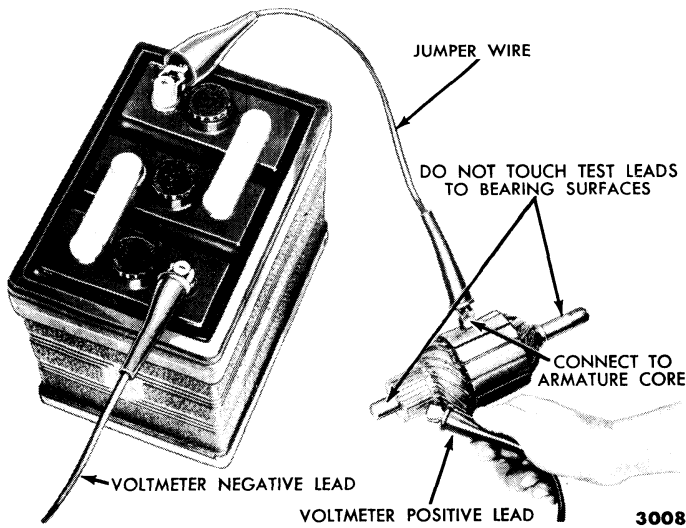

Fig. 11—Grounded Circuit Armature Test

(3) **FIELD TESTS.** Only two tests are necessary for checking the field. Both open and short circuits can be tested in one operation. The second test is for a grounded circuit.

(a) **OPEN OR SHORT CIRCUIT TEST.** The field can be checked for open and short circuits either on or off the vehicle.

(1) **ON VEHICLE.** Disconnect the "FIELD" lead from the generator terminal. Connect a 0-5 ammeter from the battery to the "FIELD" terminal as shown in fig. 12. The normal current draw, as indicated by the ammeter, should be 1.4 to 1.6 amperes. If there is little or no current flow, the field has a high resistance or is open. A current flow, considerably higher than that specified above, indicates shorted turns.

(2) **OFF VEHICLE.** The field circuit can be tested off the vehicle in the same manner as described in the "on vehicle" test above with the exception that a return lead must be used to connect the generator frame to the battery (fig. 13).

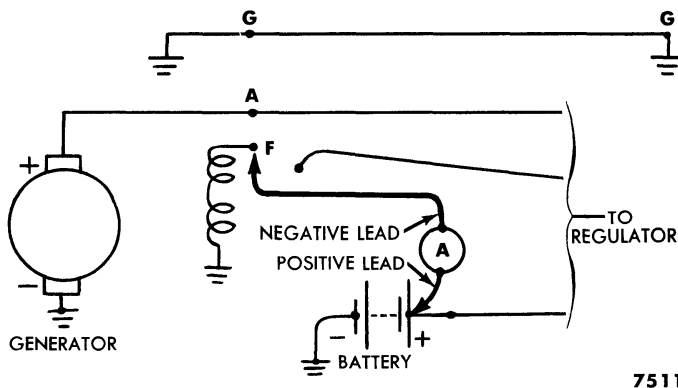

Fig. 12—Open Circuit Test of Field—Schematic

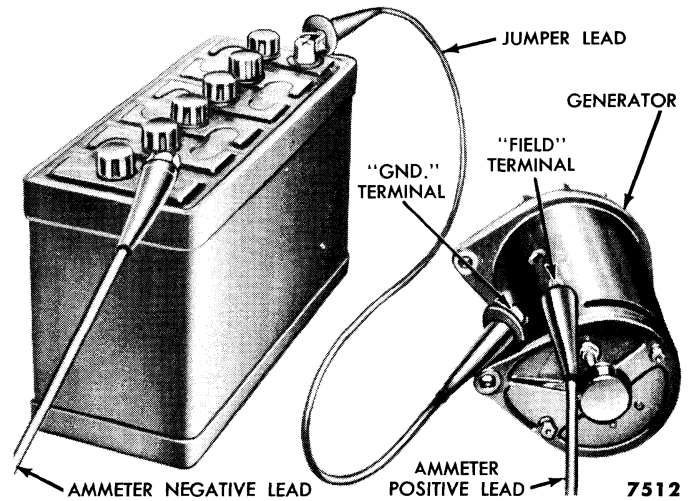

Fig. 13—Open Circuit Test of Field—Off Vehicle

(b) **GROUNDING TEST—OFF VEHICLE ONLY.** To test the field windings for a grounded circuit, remove the "GRD" terminal stud from the generator frame. Make the voltmeter and battery connections as shown in fig. 14. If the voltmeter indicates any voltage, the field coils are grounded.

NOTE: Be sure that the "GRD" terminal stud is not touching the housing.

b. Generator Repair.

Of the five repair operations outlined in this paragraph, the first, "(1) Removal and Installation" must be used when performing any one of the other four. The complete disassembly procedure is given in "(2) Overhaul." However, "(3) Armature Replacement," "(4) Commutator Turning and Undercutting," and "(5) Brush Replacement" can be accomplished without

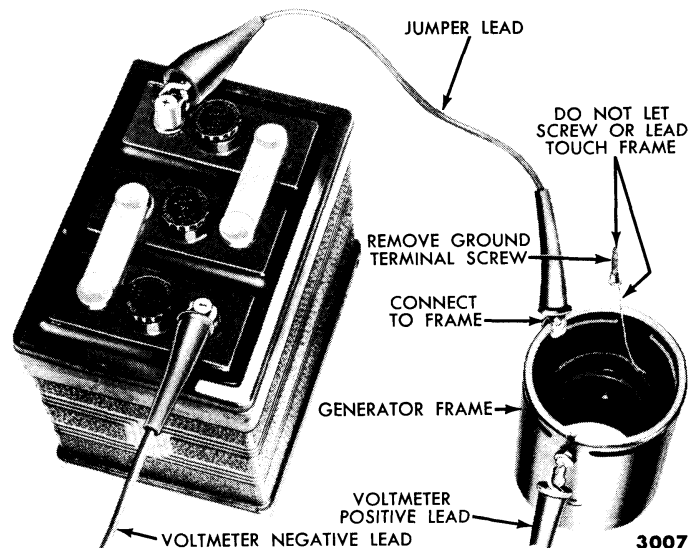

Fig. 14—Grounded Circuit Test of Field—Off Vehicle

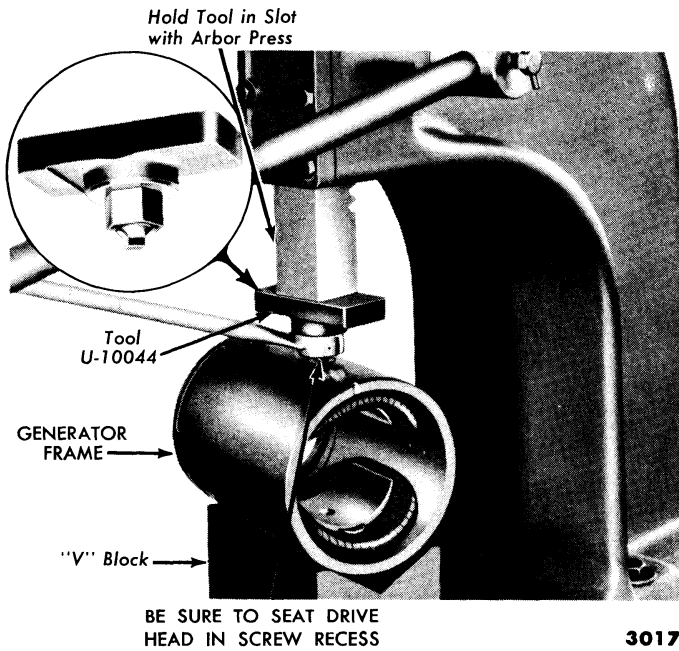

Fig. 15—Pole Shoe Screw Removal

completely disassembling the generator. Therefore, these latter procedures eliminate those disassembly steps that do not apply.

(1) **REMOVAL AND INSTALLATION.** Disconnect the armature, field, and ground wires at the generator terminals.

Remove the adjustment arm to generator bolt, the generator belt, and the two pivot bolts from the mounting bracket. Then remove the generator (fig. 7).

To install the generator, first clean the mating surfaces of the generator frame and mounting bracket. Install the generator in the bracket with the two pivot bolts and lockwashers. Install the generator belt, and the adjustment arm to generator bolt. Adjust the belt tension and tighten all bolts securely. Install the armature, field, and ground leads on the generator terminals.

(2) **OVERHAUL.** Use the procedures outlined below for generator overhaul or when it is necessary to completely disassemble a generator for such purposes as bearing replacement or field coil replacement.

(a) **DISASSEMBLY.** Remove the two generator through bolts and the brush end plate. Slide the armature assembly out the other end of the frame. Do not lose the locating dowels if they drop out of the end plates. Clamp the armature in a vise equipped with soft jaws, and remove the retaining nut, lockwasher, pulley, and woodruff key from the armature shaft. Slide the front end plate off the armature shaft.

NOTE: *Be sure to remove any burrs from the keyway before removing the front end plate.*

Pry out the bearing stop ring (snap ring), and push the bearing out of the front end plate.

Remove the "ARM" terminal screw and positive brush from the brush end plate. Remove the ground brush screw and the ground brush. On 8-cylinder engine generators, remove the bearing snap ring and bearing from the plate.

Remove the "FIELD" and "GRD" terminal screws from the generator frame, and unscrew the field pole shoe screws as shown in fig. 15. The arbor press prevents the tool from slipping out of the screw socket. Slide the pole shoes and field windings out of the frame, and separate the windings and shoes.

(b) **CLEANING AND INSPECTION.** Wash all parts except the armature, field coils, and ball bearings in solvent and dry the parts thoroughly. Wipe off the armature and field windings, the commutator, and the armature shaft.

Check the condition of the bearings. If the ball bearing is worn or has lost its lubricant it must be replaced. If the 6-cylinder engine generator brush end plate bushing is worn or scored, replace the brush end plate assembly.

Check the armature winding for worn insulation, overheating, and unsoldered connections. Check the armature for shorts, opens or grounds. Check the field windings for worn insulation and unsoldered connections at the terminal screws. Resolder any connections as required. Replace the armature or the field coils if the insulation is worn.

Check the commutator for runout and uneven or scored surfaces. Turn down the commutator and undercut the mica if necessary.

Inspect the brush end plate for cracks, poor insulation, or loose rivets. Replace the end plate if it is cracked or if the positive brush insulation is broken or cracked. Tighten any loose brush holder rivets.

Check the brush spring tension. If the tension is not between 26-34 ounces, replace the springs.

(c) **ASSEMBLY.** Install the field coils on the pole shoes, and mount the shoe and coil assemblies in the frame. Tighten the field pole shoe screws (fig. 15).

NOTE: *As the screws are tightened, strike the frame several sharp blows with a soft faced hammer to seat and align the pole shoes.*

Install the "GRD" terminal screw, washer, and nut in the frame. Install the "FIELD" terminal screw, insulators, washer, and nut in the frame.

Insert the brushes in the brush holders, install the "ARM" terminal screw and insulators, and install the ground brush screw. Move the brushes back in the

holders until the brush springs ride against the side of the brushes to retain them in the retracted position. On 8-cylinder engine generators, first install the bearing in the brush end plate and insert the snap ring.

Install the bearing in the front end plate and insert the bearing stop ring. Slide the plate on the armature shaft (with the snap ring toward the armature windings), and install the woodruff key, pulley, lockwasher, and retaining nut. Install the armature and front end plate assembly in the frame, locating the dowel in the frame groove. Install the brush end plate (aligning the dowel and frame groove), and install the through bolts with lockwashers. Use a piece of stiff wire with a hooked end to reach through the ventilating slots, and position the brush springs on top of the brushes. Lubricate the brush end plate bushing with a few drops of engine oil (6-cylinder engine generators).

(d) **POLARIZING GENERATORS.** Normally, it is only necessary to polarize a generator when a generator has been rebuilt and if new pole shoes have been installed. Generators are polarized during manufacture, and normally, there is enough residual magnetism left to allow the generator to start charging.

To polarize a rebuilt generator mounted on the vehicle, disconnect the field wire and the battery wire from the regulator and momentarily contact the two wires together, engine not running.

CAUTION: *Do not polarize a generator by any method that applies battery voltage to the field terminal of the regulator, such as shorting from the battery terminal to the field terminal of the regulator, or by connecting a jumper wire directly from the battery to the generator field terminal. This action causes excessive current to flow from the battery through the regulator contacts to ground, thus burning the points.*

(3) **ARMATURE REPLACEMENT.** Remove the two through bolts and the brush end plate. Slide the armature and front end plate assembly out of the frame. Clamp the armature in a vise equipped with soft jaws, and remove the retaining nut, lockwasher, pulley, and woodruff key. Remove any burrs or scratches from the keyway or shaft, and slide the drive end plate off the shaft.

Install the front end plate on the new armature. Install the woodruff key, pulley, lockwasher, and retaining nut. Slide the armature and front end plate assembly in to the frame, aligning the dowel with the frame slot. Retract the brushes until the brush springs ride against the side of the brushes, and install the brush end plate (aligning the dowel and the frame slot). Install the through bolts with lockwashers.

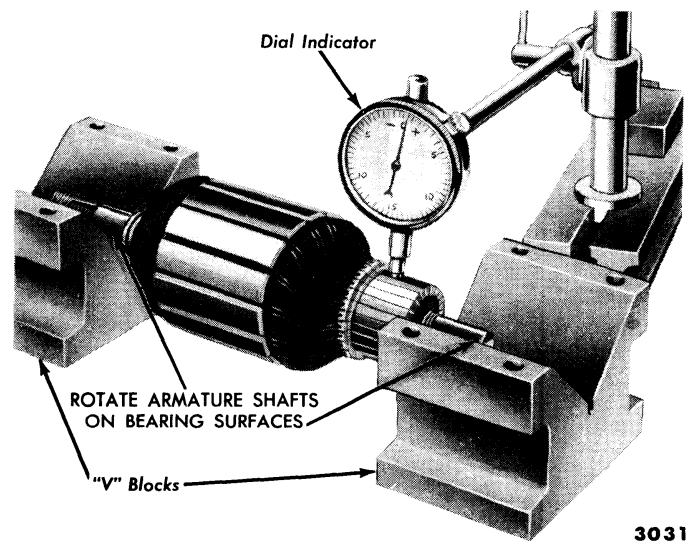

3031

Fig. 16—Commutator Runout Check

Use a piece of stiff wire with a hooked end to reach through the ventilating slots, and position the brush springs on top of the brushes. Lubricate the brush end plate bushing with a few drops of engine oil (6-cylinder engine generators).

(4) **COMMUTATOR TURNING AND UNDERCUTTING.** Check the commutator runout as shown in fig. 16. If the surface of the commutator is rough or more than 0.002 inch out of round, turn it down in a lathe or with a turning and undercutting tool (fig. 17). Remove no more copper than necessary to clean up the commutator.

After the commutator is turned down, undercut the mica between the bars $\frac{1}{32}$ inch below the copper using the undercutting tool as shown in fig. 18. Figure 19 illustrates samples of proper and improper undercutting.

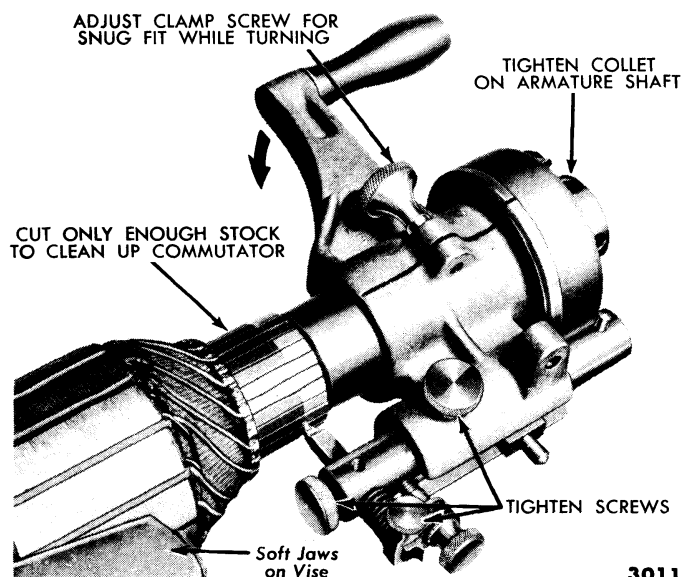

3011

Fig. 17—Generator Commutator Turning

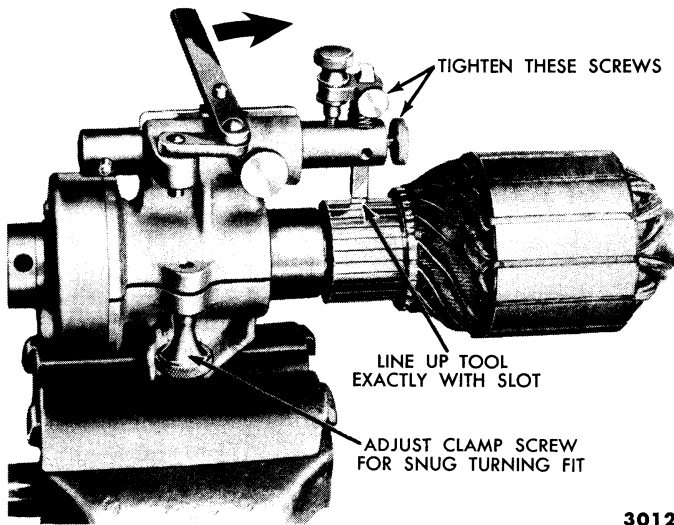

Fig. 18—Generator Commutator Undercutting

Polish the commutator with 00 to 000 sandpaper to remove all burrs.

NOTE: *Brush all particles of copper from the mica insulation between the commutator segments.*

(5) **BRUSH REPLACEMENT.** Replace the genera-

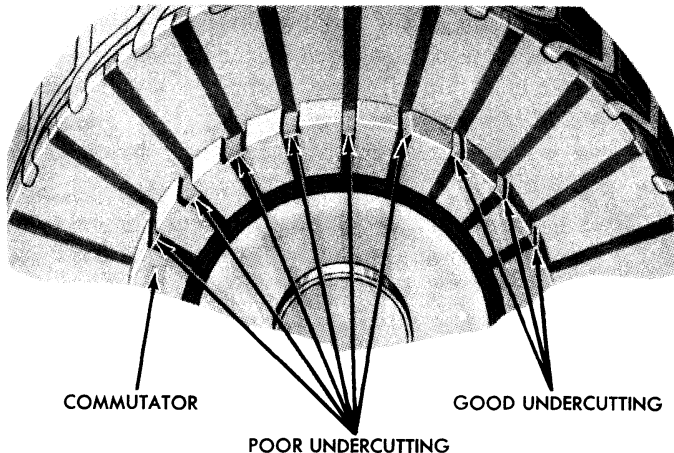

Fig. 19—Examples of Proper and Improper Undercutting

3. GENERATOR REGULATOR

The generator regulator is composed of three control units mounted as an assembly (figs. 21, and 22). Each unit has a set of contact points and an energizing coil for operating the points, and each of the units performs a separate function to maintain control of the generator.

When the engine is not operating, the contact points on the cut-out relay (fig. 1), are held open by spring tension. In this way, the cut-out relay prevents the battery from being discharged through the low-resis-

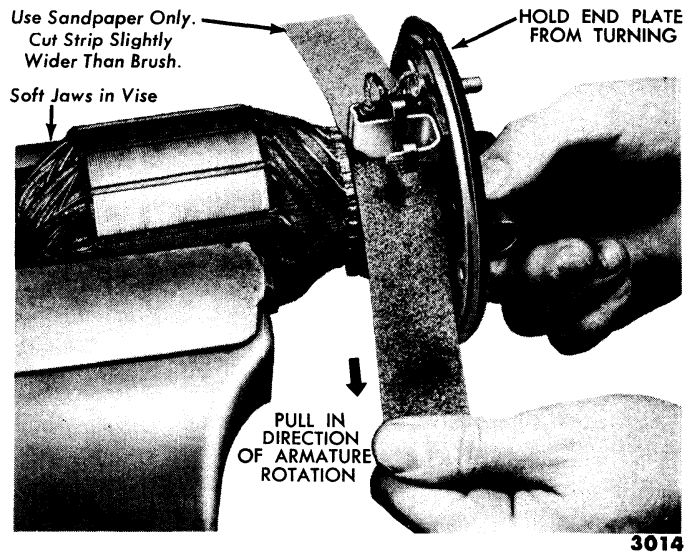

Fig. 20—Generator Brush Seating

tor brushes when they are worn to $\frac{1}{2}$ inch. Always change both brushes when replacement is required.

Remove the two through bolts from the generator frame. Remove the brush end plate and the armature and front end plate assembly from the generator frame. Disconnect the brush terminals and remove the brushes. Clean the carbon and dirt from the brush end plate. Repair or replace the insulation between the brush holders and end plate and the "ARM" terminal and end plate if it is worn or cracked. Make sure that the new brushes slide freely in the brush holders. Seat the new brushes by sanding them in as shown in fig. 20.

Retract the brushes until the brush springs ride against the side of the brushes to retain them in the retracted position. Install the armature and front end plate assembly and the brush end plate (aligning the dowels and the frame slots). Install the through bolts with lockwashers. Use a piece of stiff wire with a hooked end to reach through the ventilating slots and position the brush springs on top of the brushes. Lubricate the brush end plate bearing cup with a few drops of engine oil (6-cylinder engine generators).

tance generator armature to ground. When the engine starts, the voltage, induced in the generator armature, forces current through the energizing coils of the cut-out relay. At approximately 12 volts, the coils are energized sufficiently to overcome the spring tension and close the cut-out points. With the points closed, the current can now flow from the generator to the external load. When the generator voltage drops sufficiently below the battery voltage to de-energize the

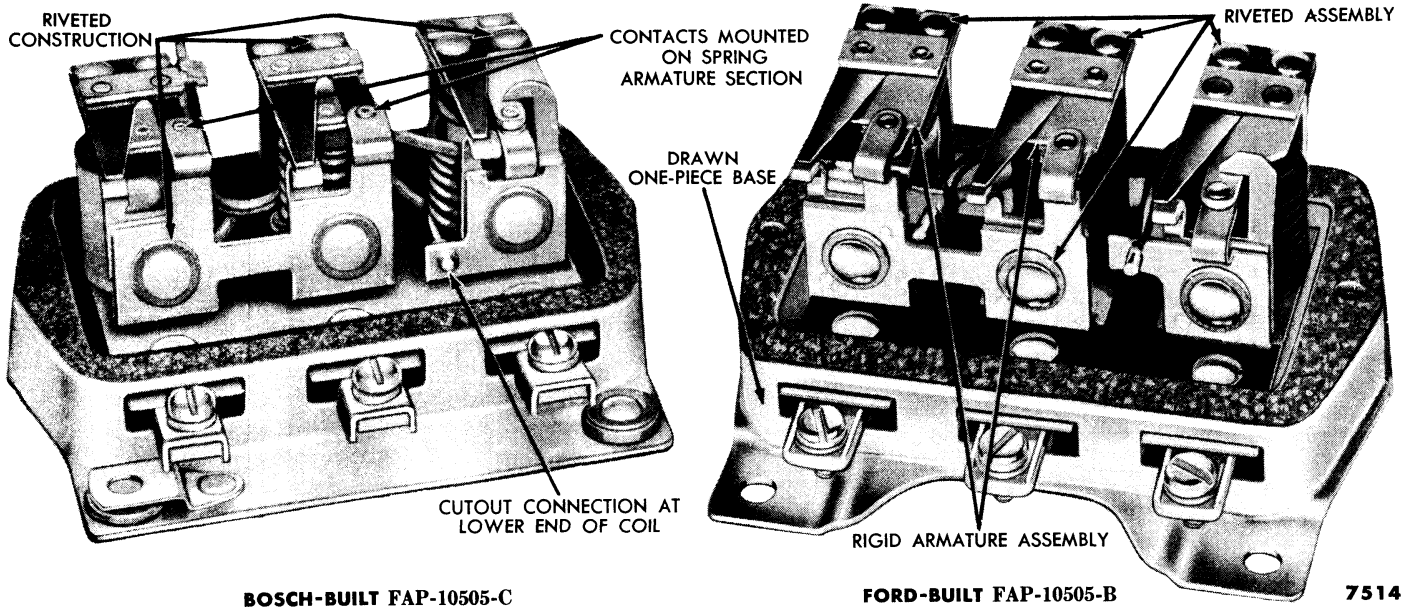

Fig. 21—Generator Regulator

cut-out relay coils, the spring tension again opens the points to disconnect the generator from the external load, and prevents the battery from discharging through the generator. Before the cut-out contacts open, a small amount of reverse current will flow from the battery to the generator.

The voltage limiter holds the generator voltage below a predetermined setting by controlling the amount of voltage applied to the field coils. This can be accomplished only as long as the voltage of the generator is high enough to operate the voltage limiter. When the engine is not operating, the contact points in both the voltage and current limiter units (fig. 1), are held closed by spring tension. When the engine starts, voltage, induced in the generator armature, causes current to flow through both sets of points to the field coils. The greater the field strength, resulting from this current, the greater is the generator output voltage from the armature. When this increased output voltage energizes the voltage limiter coil, sufficiently to open the points, the current to the field coils is cut off. The resulting weakening of the field decreases the generator output voltage. As the generator voltage decreases sufficiently to de-energize the voltage limiter coil, spring tension again closes the points to provide current for the field. The voltage limiter contacts open and close at a rate of about 60 to 200 times a second to accomplish control of the generator voltage, and thus protects the system from high voltage when the system load demand is low.

The current limiter protects the generator windings

by limiting the maximum amount of current supplied by the generator. Any increase in current above the current limit setting results in a decrease in voltage, but if the voltage decreases, the voltage limiter will not operate. Therefore, when the current, drawn from the generator, reaches the current limit setting, the voltage limiter no longer functions. At this point, the current limiter assumes control. Like the voltage limiter, the current limiter performs its function by controlling the amount of current that is supplied to the generator field coils. When the generator output current becomes excessive, it energizes the current limiter coil sufficiently to open the points and, thereby, cuts off the voltage and resulting current going to the field. The resulting de-

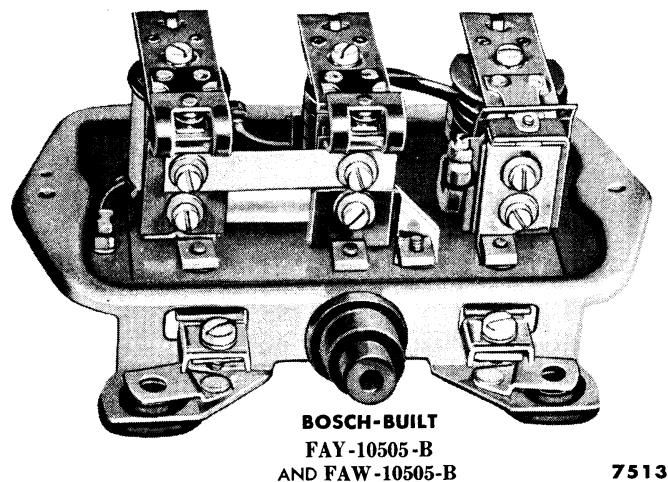

Fig. 22—Heavy Duty Regulator

Table 2—Voltage Regulation Setting Versus Ambient Air Temperature

Ambient Air Temp. in ° F.	Voltage Regulation Setting (Volts)				
	Standard Regulator (Ford and Bosch)	30 amp. Low Cut-In (Bosch)	Heavy Duty Regulators		
			40 amp. (Auto-lite)	50 amp. (Bosch)	60 amp. (Bosch)
25	15.1-15.9		14.3-15.2		
35	15.0-15.8		14.3-15.2		
45	14.9-15.7		14.3-15.1		
55	14.8-15.6		14.3-15.0		
65	14.7-15.5		14.3-14.9		
75	14.6-15.4		14.2-14.9		
85	14.5-15.3		14.1-14.8		
95	14.3-15.1		14.1-14.7		
105	14.2-15.0		14.0-14.7		
115	14.1-14.9		14.0-14.6		
125	13.9-14.7		13.9-14.5		
135	13.8-14.6		13.8-14.4		
145	13.6-14.4				

cline in field strength reduces the generator output and prevents excessive current from being drawn from the generator, and thus protects the generator when the system load demand is high.

When the current limiter is operating, the voltage limiter contacts remain closed, and the current limiter contacts open and close at a rate of about 30 or 40 times a second.

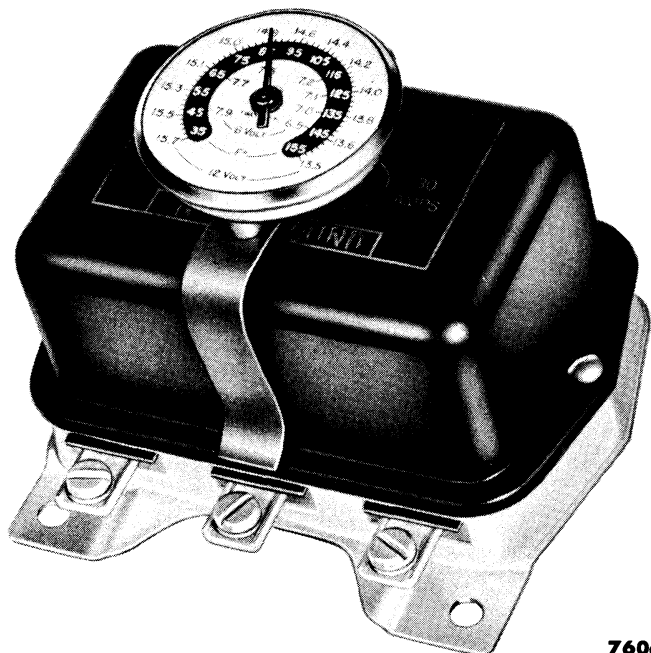

7606

Fig. 23—Voltage Regulation Setting Thermometer

a. Temperature Compensation.

The generator regulator has not only been designed to exercise automatic control over the generating system, but it will also compensate for seasonal temperature changes. In cold weather a higher voltage output is required to handle the load. In warm weather, the voltage must be reduced to avoid boiling out the battery. The temperature compensation is built into the regulator unit by making the armature hinge of bi-metal. The temperature sensitivity of the bi-metal causes the regulator voltage setting to change according to temperature. Therefore, it is necessary to establish a "Normal" or stabilized regulator operating temperature and a standard ambient (surrounding air) temperature to coincide with the specified voltage setting of 14.6 to 15.4 volts. The standard ambient air temperature established for this setting is 70° to 80° Fahrenheit. The regulator temperature for this or any setting, is defined as the temperature of the regulator after ½ hour of operation in the vehicle or, after the regulator has been heated until it becomes stabilized.

CAUTION: *For correct voltage regulation adjustment, first be sure that the regulator has reached "Normal" operating temperature as defined above; then make the voltage adjustment setting to coincide with the prevailing ambient air temperature. Table 2 shows the proper voltage limits for various ambient air temperatures, for both standard and heavy-duty regulators.*

(1) **ON THE VEHICLE.** On the vehicle, ambient air temperature will be the temperature of the engine compartment air. To measure the air temperature, first clip the voltage regulation setting thermometer (T56L-10505-A) onto the regulator cover (fig. 23).

NOTE: *The voltage regulation setting thermometer T56L-10505-A has two voltage scales, one for the 12 volt standard regulator and the other for the 6 volt standard regulator. When checking or adjusting the heavy-duty regulators, observe the temperature indicated by the thermometer and refer to Table 2 (Heavy-Duty Regulators) for the correct voltage setting.*

Run the engine to stabilize the regulator. The engine fan will cause the air in the engine compartment to circulate past the regulator until the regulator has stabilized at the ambient air temperature. After the regulator and thermometer have stabilized, the thermometer will show the voltage setting at which the regulator should be operating.

(2) **ON THE TEST BENCH.** When the regulator is mounted on a regulator test bench, the ambient air temperature will be the room temperature. Clip the

thermometer T56L-10505-A onto the regulator cover. Mount a small fan on the regulator test bench about 12 to 15 inches from the regulator. Operate the fan and the regulator to stabilize the regulator. The fan will provide sufficient air flow to ensure stabilization of the regulator at the temperature indicated by the thermometer. After stabilization, the thermometer will show the voltage setting at which the regulator should be operating.

b. Regulator and Circuit Tests.

Instruments and equipment for making the tests are listed below:

- | | | |
|-------|--|-----------|
| 0-50 | For Standard Regulator | } Ammeter |
| 0-100 | For Heavy Duty Regulator | |
| 0-5 | } Voltmeter | |
| 0-25 | | |
| 50 | Ohm Field Rheostat (2 amp. rating) | |
| 1½ | Ohm Resistor (15 amp. rating) | |
| | Carbon Pile Rheostat (heavy duty) | |
| | Assorted connecting wires equipped with suitable connectors. | |

Special generator-regulator test benches incorporate the above equipment in one unit. When such combined equipment is used, be sure to follow the instructions of the manufacturer.

The four tests presented here are outlined for on-the-vehicle operation and should be conducted in the sequence indicated. Be sure that the regulator is at "normal" operating temperature (equivalent to the temperature after 30 minutes of operation on the vehicle with 10 ampere load). Connect the test equipment as shown in figs. 24 and 25.

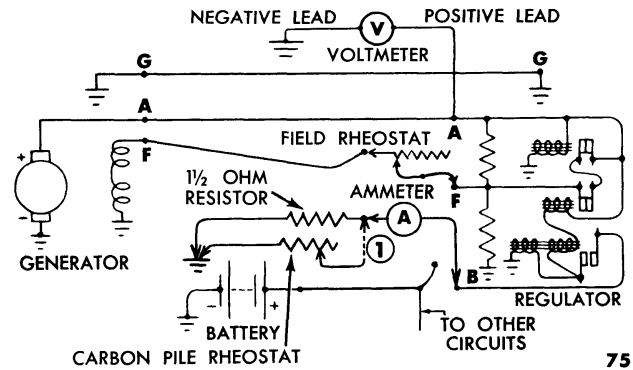

Fig. 24—Regulator Test—Schematic Test Circuit

CAUTION: Always be careful when making any test connections to the regulator, so as not to short the battery lead or terminal to the regulator field terminal. To do so will burn the regulator contacts. It is recommended that a battery cable be disconnected while making these connections.

(1) **CUT-OUT TEST.** Start the engine and run it at approximately 1500 r.p.m. Decrease the resistance in the field circuit, and the voltage output of the generator, indicated by the voltmeter, will increase until the cut-out closes. The cut-out closing will be indicated by a rise of the ammeter needle and a "dip" of the voltmeter needle. The maximum voltage at the time the voltmeter needle dips or drops back will be the closing voltage of the cut-out relay. This operation should be repeated to accurately determine the closing voltage of the cut-out.

(2) **VOLTAGE LIMIT TEST.** Reduce the resistance in the field circuit to zero. The ammeter should show an approximate 10 ampere load. Read the voltage regulation on the voltmeter scale. Speed the engine momen-

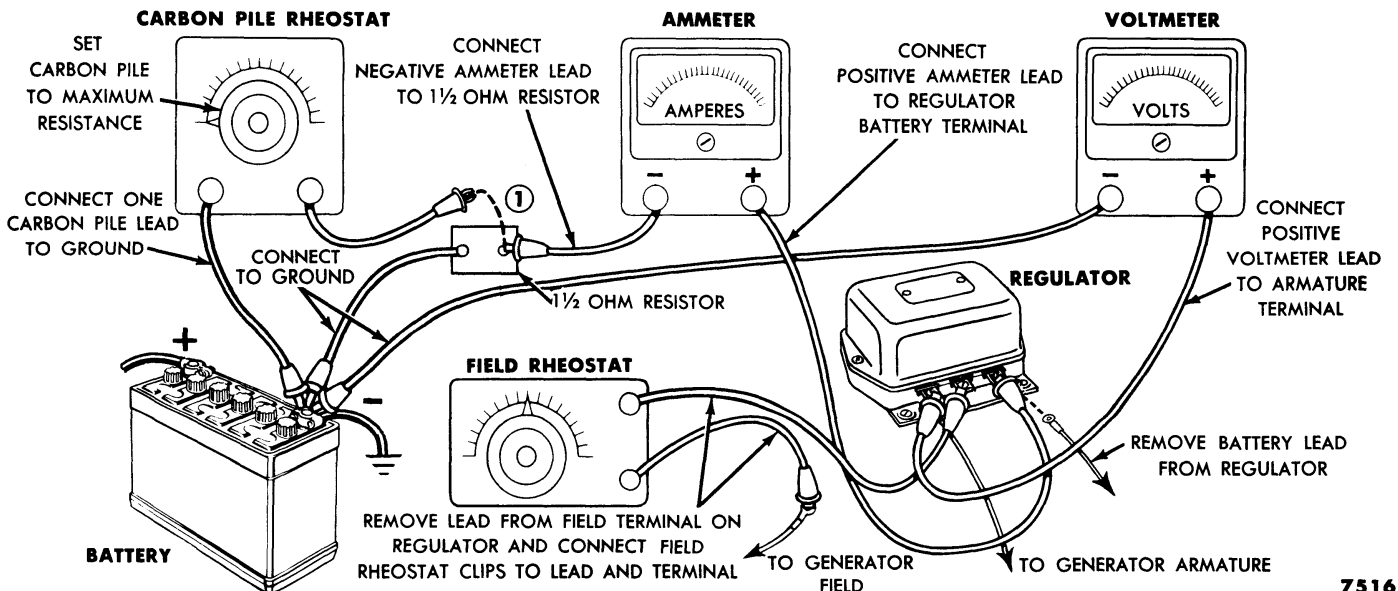

Fig. 25—Regulator Test Connections

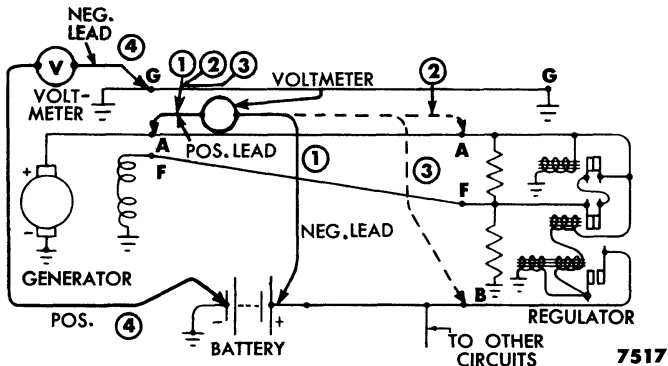

Fig. 26—Regulator External Circuit Test—Schematic

tarily to see if the voltage remains regulated.

On the Bosch built heavy-duty regulators, run the engine at 700 r.p.m. and observe the voltage regulation on the voltmeter. The voltage should read within the specified limits for the lower stage regulation. Increase the engine speed to 1500 r.p.m. The voltage regulation should read within the specified limits for the upper stage regulation and also must be for 0.1 volt to 0.3 volt above the lower stage regulation.

(3) **CURRENT LIMIT TEST.** Connect the carbon pile rheostat across the 1½-ohm resistor, (connection marked ① figs. 24 and 25). With the engine speed at 1500 r.p.m., slowly decrease the resistance of the rheostat until the voltmeter reading drops to 13 volts. The ammeter will indicate the setting of the current limiter.

On the Bosch built heavy-duty regulator, run the engine at 700 r.p.m. Decrease the resistance of the carbon pile rheostat until the voltmeter reading drops to 13 volts. The ammeter will indicate the current setting for the lower stage current limitation.

To measure the upper stage current limitation, connect a 1.25 ohm 25 watt resistor between the generator field terminal and the generator armature terminal. With the engine speed at 1500 r.p.m. and the generator loaded to reduce the voltage output to 13 volts, the ammeter will indicate the upper stage current limit. The upper

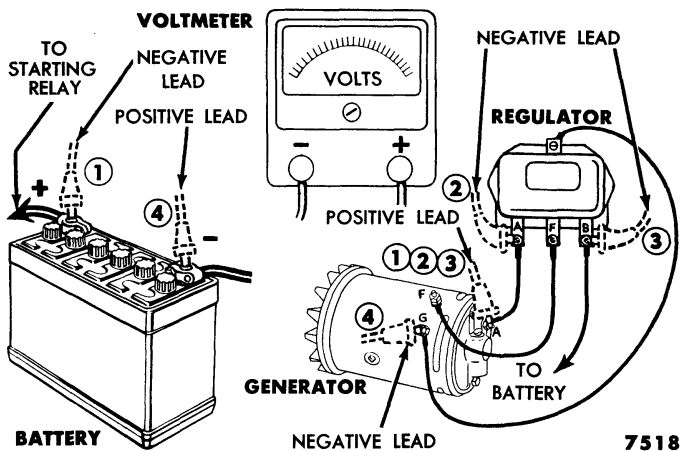

Fig. 27—Regulator External Circuit Test Connections

stage current limit should be within the specified limits and also 0.1 to 0.3 ampere above the lower stage current limit. Remove the resistor after making any necessary adjustments.

Remove all test leads except the voltmeter leads. Install the "BAT," and "FIELD," leads on the regulator terminals. Run the engine at 1500 r.p.m., and read the voltage regulation (under battery load) on the voltmeter.

NOTE: *The voltage reading will usually be low when the engine is first started because the battery is partially discharged. After a few moments of operation, the voltage will rise to the original value.*

(4) **EXTERNAL CIRCUIT RESISTANCE TEST.**

For the purpose of this test, the resistance values of the circuit have been converted to voltage drop readings for a current flow of 30 amperes. Connect the test equipment as shown in figs. 26 and 27 to measure voltage drop around the circuit.

Crank the engine for 15 seconds with the ignition switch OFF to partially discharge the battery. Then start the engine and run it at approximately 1500 r.p.m.

Touch the voltmeter negative lead to the center of the positive battery post (figs. 26 and 27, connections marked ①) to check the generator to battery circuit. The voltage drop should be less than 0.9 volt.

If the voltage drop in the generator to battery circuit exceeds 0.9 volt, locate the exact part of the circuit wiring causing the trouble, by contacting the positive lead to other points in the circuit. Connect the lead to the "ARM" terminal of the regulator (connections marked ②). The voltage drop should be less than 0.1 volt. Connect the lead to the "BAT" terminal of the regulator

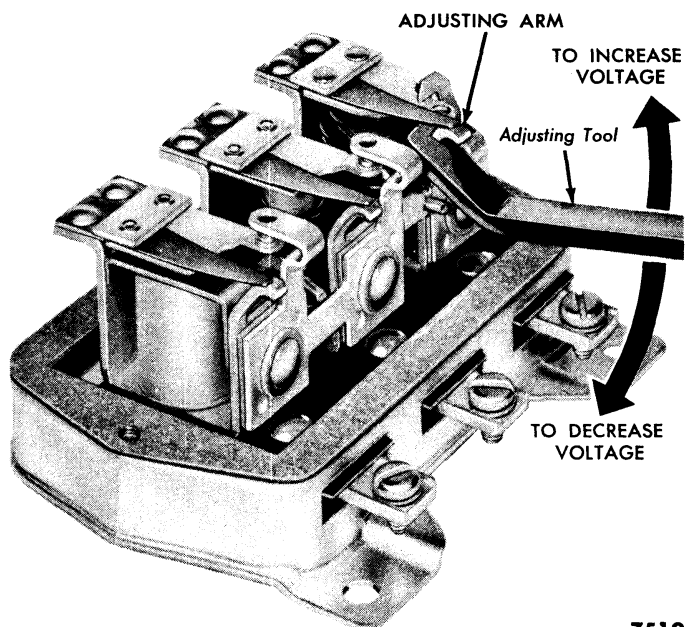

Fig. 28—Cut-in Voltage Adjustment

(connections marked ③). The voltage reading should be less than 0.35 volt. If both these readings are within limits, the excessive resistance is in the regulator to battery wires or their connections.

Check the battery to generator ground circuit by connecting the voltmeter as shown in figs. 26 and 27 (connections marked ④). The voltage reading should be less than 0.1 volt.

c. Regulator Electrical Adjustment.

Final adjustment of the regulator must be checked with the regulator at normal operating temperature. For any of the adjustments given below, remove the cover by removing the two cover screws.

(1) **ADJUST CUT-IN VOLTAGE.** The cut-in voltage is increased by bending the adjusting arm upward, or decreased by bending it downward (fig. 28).

NOTE: *After the adjustments have been made, recheck the settings with the cover in place.*

To adjust the cut-in voltage on the heavy-duty Bosch built regulator, bend the cut-out spring adjusting arm upward to decrease cut-in voltage, and downward to increase cut-in voltage (fig. 29).

(2) **ADJUST VOLTAGE LIMIT.** Make a regulator voltage setting test with the cover on. If the regulator voltage is not within the limits as shown in the table, for the ambient temperature involved, compute the difference as a positive or negative correction. Remove the regulator cover and make a new regulator voltage limit test. Adjust the new setting either up or down by the amount of the correction just computed. If the voltage is less than that specified, increase the spring tension by bending the adjusting arm upward (fig. 30). To decrease the voltage, bend the adjusting arm downward. Check the voltage setting with the regulator cover

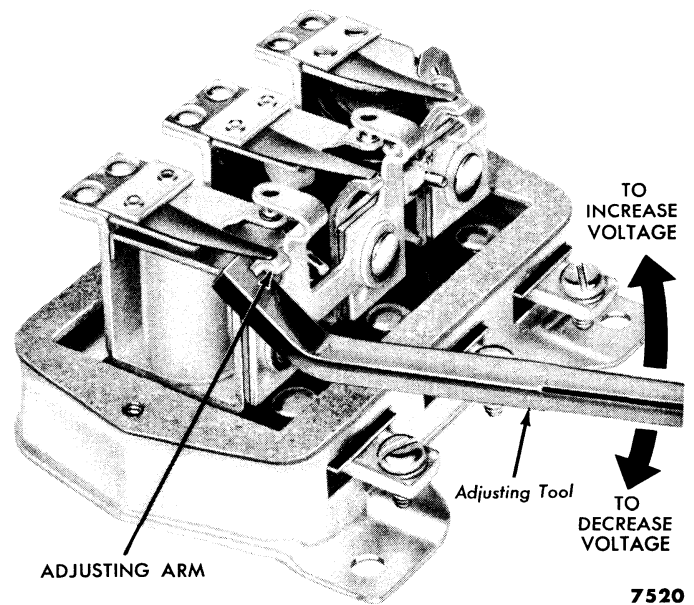

Fig. 30—Voltage Limit Adjustment

replaced.

On the Bosch built heavy-duty regulator, to adjust the voltage limit, bend the voltage limiter spring adjusting arm upward to decrease the voltage and downward to increase the voltage (fig. 29). Recheck the voltage with the cover temporarily in place. Readjust the voltage limiter if necessary.

(3) **ADJUST CURRENT LIMIT.** If the current limit on the standard regulator is less than that specified, increase the spring tension by bending the adjusting arm upward (fig. 31). To decrease the current limit, bend the adjusting arm downward. Install the cover.

For the current limit adjustment on the Bosch built heavy-duty regulator, bend the current limiter spring

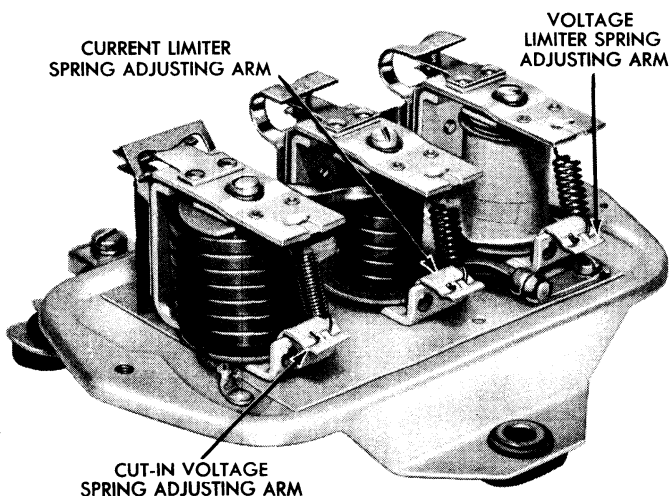

Fig. 29—Bosch Built Heavy-Duty Regulator Adjustments

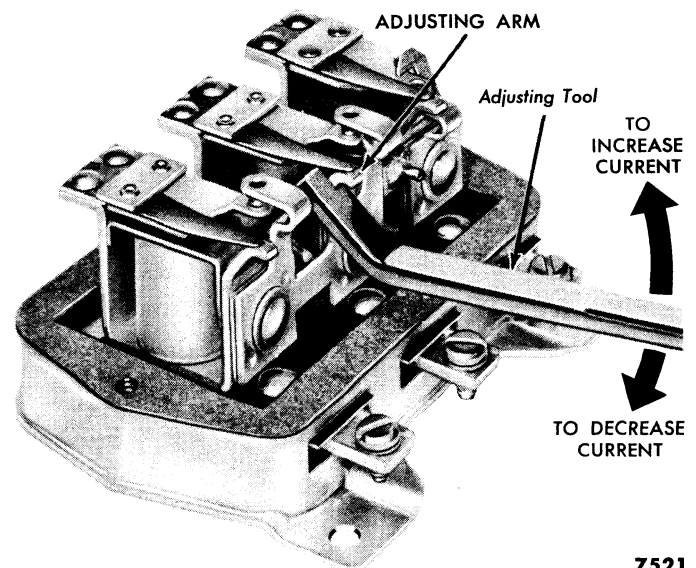

Fig. 31—Current Limit Adjustment

adjusting arm upward to decrease the current and downward to increase the current (fig. 29). Install the cover gasket, cover, and screws.

d. Regulator Replacement.

Disconnect the battery ground cable. Disconnect the "ARM," "FIELD," and "BAT" leads at the regulator terminals. Remove the mounting screws and the regulator.

NOTE: *It is advisable to disconnect a battery cable when working on the regulator to prevent an accidental short circuit of the "BAT" lead to the ground.*

To install the regulator, place it in position and install the mounting screws. Mount the ground wire terminal under the mounting screw at the back of the standard regulator. Connect the "ARM," "FIELD," and "BAT" regulator terminals. Connect the battery ground cable.

4. BATTERY

The primary function of the storage battery in the generating system is, as its name implies, to store energy for starting the engine and to operate electrical units when the generator is not delivering sufficient output.

A cutaway view of the 12-volt battery (fig. 32) illustrates the internal construction.

a. Battery Tests and Conclusions.

Tests are made on a battery to determine the state of charge and also the condition. The ultimate result of these tests is to show that the battery is good, needs recharging, or must be replaced.

If a battery in a vehicle is low in charge, good service demands that you look for a reason for this condition.

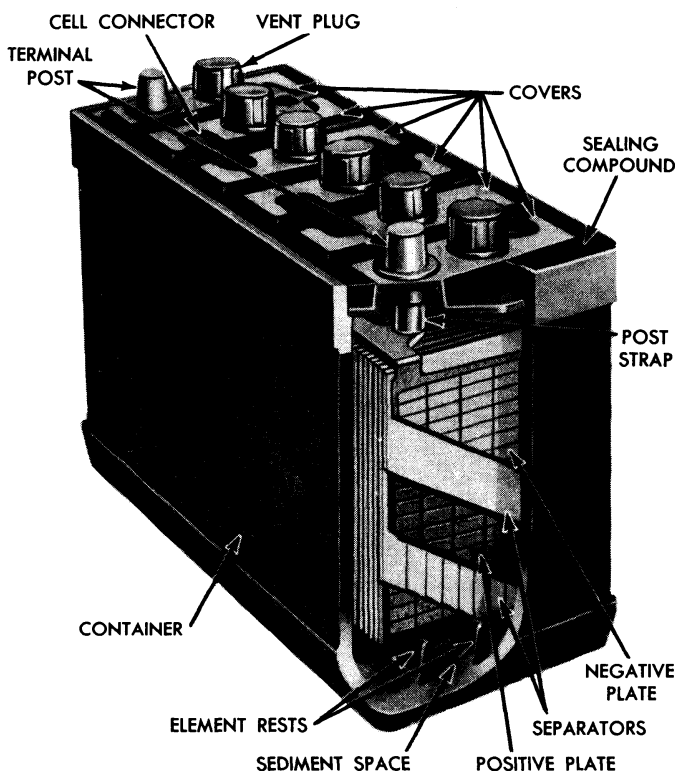

7524

Fig. 32—Battery Construction Details

It may be necessary to follow trouble shooting procedures to locate the cause of the trouble.

Equipment required to make the various battery tests include:

0-20 voltmeter

Hydrometer or meter type charge tester

Fast charger

High rate discharge tester

Some battery test equipment combines the necessary instruments and controls in a single unit. Be sure to follow the directions of the manufacturer when using such combined equipment.

WARNING: *Hydrogen and oxygen gases are produced in the course of normal battery operation. Flames or sparks can cause this gas mixture to explode if they are brought near the vent openings of the battery. The sulphuric acid in the battery electrolyte can cause a serious burn if spilled on the skin or splattered in the eyes. It should be flushed away immediately with large quantities of clear water.*

b. Before Charge Tests.

Much can be learned about the condition of a battery, even though the battery is only partially charged. Generally, a capacity test made on a battery having less than a full charge will indicate a combination of charge and condition and will thus be inconclusive. However, under certain conditions, a capacity test on a partially charged battery will indicate that a battery is in good condition and only needs to be charged. The following battery capacity test will indicate these conditions.

(1) **BATTERY CAPACITY TEST.** A battery capacity test is made by causing current to flow from the battery at a rate according to the size of the battery and measuring the terminal voltage at the battery under load. A high-rate discharge tester in conjunction with a voltmeter is used for this purpose. Add water if necessary to bring the battery solution to the proper level. Connect the high-rate discharge tester and the appro-

appropriate voltmeter to the battery terminals. Adjust the discharge tester to draw three times the ampere hour rating of the battery. After 15 seconds and with the battery still under load, read the battery terminal voltage.

NOTE: *The voltmeter clips must contact the battery posts and not the high rate discharge tester clips. Unless this is done the actual battery terminal voltage will not be indicated.*

If the terminal voltage is 9.25 volts or more, the battery has good output capacity and will accept a normal charge. Test the specific gravity if water has not been recently added, and recharge if necessary.

If the terminal voltage is below 9.25 volts, make a test charge on the battery.

NOTE: *When making a capacity test in areas where consistent zero temperatures occur, the terminal test limit voltage should be increased from 9.25 to 9.65 volts.*

(a) **BATTERY TEST CHARGE.** The condition of a discharged battery may be tested by passing current through it. Connect a fast charger to the battery and charge the battery for 3 minutes at a rate of 30 amperes.

After 3 minutes of fast charge, and with the fast charger still operating, test the individual cell voltages of the battery.

If the cell voltages vary more than 0.1 volt, replace the battery.

If the cell voltages are even within 0.1 volt, test the total battery voltage (charger still operating).

If the total battery voltage is now under 15.5 volts, the battery is satisfactory and may be safely fast charged (see Table 3). Always follow the fast charge with sufficient slow charge to bring the battery to a full charge.

If the total battery voltage was over 15.5 volts, the battery is probably sulphated. Place the battery on continued slow charge, and follow the instructions under, "c. After Charge Tests".

(2) **BATTERY CHARGE TESTS.** Battery charge may be tested by measuring the battery electrolyte solution specific gravity (hydrometer) or by measuring the voltage of the battery cells on open circuit (no current flow) with a battery charge tester (open circuit voltage tester).

(a) **HYDROMETER.** The hydrometer can be used only when there is sufficient electrolyte above the battery plates to fill the hydrometer tube.

NOTE: *Do not take hydrometer readings immediately after refilling a battery with distilled water.*

Remove the battery filler plugs. Draw electrolyte in and force it out of the hydrometer barrel several times

to bring the temperature of the hydrometer float to that of the electrolyte, then draw in just enough electrolyte to lift the float. Read the specific gravity on the float scale. A specific gravity of 1.275-1.285 indicates a fully charged battery, 1.230-1.240 indicates approximately 60% charge.

NOTE: *Some warm climate areas supply batteries with electrolyte of 1.260 specific gravity. This type of battery is fully charged at 1.260 specific gravity and is plainly marked to indicate the lower specific gravity.*

(b) **BATTERY CHARGE TESTER.** The battery charge tester provides a clean, convenient, and rapid means of testing battery state of charge. A sensitive voltmeter measures the open circuit voltage of each cell and indicates the charge in the battery on the voltmeter scales.

It eliminates the removal of battery electrolyte from the battery (as compared to the hydrometer check) preventing acid burns on the operator, clothes, and car finish. In many cases, it is impossible to test the battery with the hydrometer because the electrolyte is below the plates and cannot be drawn out of the cell. The battery charge tester tests the state of charge of a battery by measuring the voltage of the battery cells on open circuit (no current flow). It consists of an accurate, expanded-scale voltmeter equipped with test prods which are contacted to the terminals of each cell. The scale of the meter shows cell voltage from 1.9 volts to 2.3 volts in $\frac{1}{100}$ volt divisions.

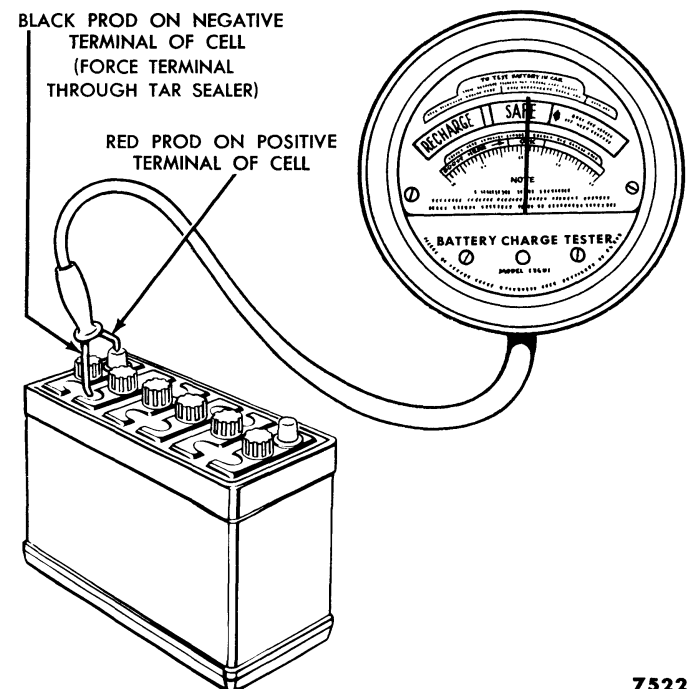

Fig. 33—Battery Charge Tester

Table 3—Allowable Fast Charge Time

Specific Gravity	Fast Charge Up To
1.150 or less	1 hour
1.150 to 1.175	$\frac{3}{4}$ hour
1.175 to 1.200	$\frac{1}{2}$ hour
1.200 to 1.225	$\frac{1}{4}$ hour
Above 1.225	Slow Charge Only

To make the battery test, contact the meter prods to the proper cell terminals (red to positive, black to negative) as shown in fig. 33, and observe the reading on the meter scales. If the reading is in the red portion of the scale, the battery is less than 60% charged and will not supply enough current to start an engine in extremely cold weather. If the reading is near the red scale, the battery is approximately 65% charged, and its starting power is questionable.

When testing a battery which has been charged just previous to the test, "surface charge" in the battery will give a false reading. To remove "surface charge," turn on the headlights of the vehicle for the length of time indicated by the top scale of the meter, then turn off the headlights and read the state of charge of the battery.

When testing batteries in stock (not on trickle charger) use the bottom scale of the meter as a guide for state of charge.

CAUTION: A 12-volt battery can be more easily discharged to the point where it will freeze during cold weather than a standard 6-volt battery. A 12-volt battery discharged to the point where it will easily freeze will still crank the engine.

c. After Charge Tests.

After charge tests must be made to check apparently sulphated batteries that have been put on continued slow charge to try to make them serviceable. When the

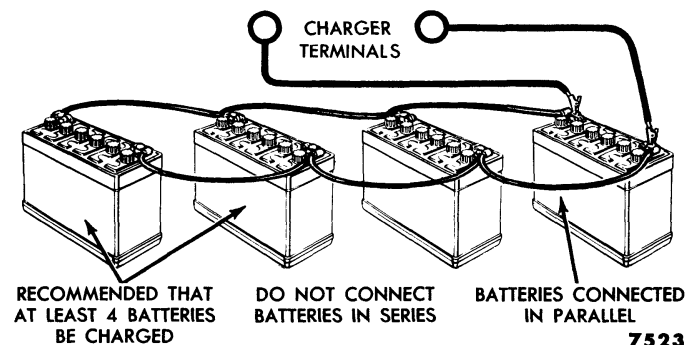

Fig. 34—Slow Charge Procedure

battery is fully charged (check with a hydrometer or battery charge tester) make a capacity test, as in "Before Charge Tests." If the terminal voltage is 9.25 volts or above, place the battery back in service. If the terminal voltage is below 9.25 volts, replace the battery.

d. Care of Batteries in Stock.

The oldest batteries should be sold first. A slow discharge occurs during storage, and the number of "boost" charges required by a battery before it is finally sold will be reduced by rotating stocks properly.

The date of manufacture of the battery is "burned in" on one of the cell covers. The first character, 1-2-3-4-5-etc., represents the year. The second character, 1-2-3-4-5-6-7-8-9-O-A-B-, designates the month. The third character, 1-2-3-4-, and sometimes 5, signifies the week of the month. Thus the code 5-B-3 indicates that a battery was manufactured during the third week of December, 1955.

To assure trouble-free operation on a new battery installation, the battery should be fully charged at the time it is installed.

e. Battery Charging.

A battery that is not sulphated may be charged by either the fast charging or slow charging method. Most fast charge units may be adjusted for making a slow charge.

Wash all dirt from the battery, and clean the battery terminals before placing it on charge.

NOTE: Do not allow dirt to enter the cells.

Bring the electrolyte to the correct level in the cells. If the battery is extremely cold, allow it to warm up before adding water as the level will rise due to expansion in the cell chamber.

(1) **FAST CHARGING.** As most fast chargers are slightly different from each other, follow the instructions for your particular equipment when connecting the unit to the battery.

Make a gravity test first, using either a hydrometer or a battery charge tester. Then fast charge at from 30 to 40 amperes maximum for the length of time shown in Table 3 corresponding to the specific gravity measured.

NOTE: Always follow a fast charge with sufficient slow-charging to bring the battery to a full charge.

(2) **SLOW CHARGING.** When a fast charger is used for slow charging, connect the batteries in parallel (fig. 34).

NOTE: Never connect batteries in series for slow charging on a fast charger; it will damage the rectifier unit.

Part THREE

ELECTRICAL AND ACCESSORIES

Chapter II

Starting System

Section		Page
1	Trouble Shooting	235
2	Starter and Circuit	238
3	Starter Drive	244

The function of the starting system is to crank the engine at a high enough speed to permit it to start. The system includes the starter motor and drive, the battery, a remote control starter switch, and heavy circuit wiring.

A schematic diagram of the starting circuit, shown in fig. 1, illustrates the internal connections of the starting system units.

Vehicles equipped with Fordomatic have a lock-out

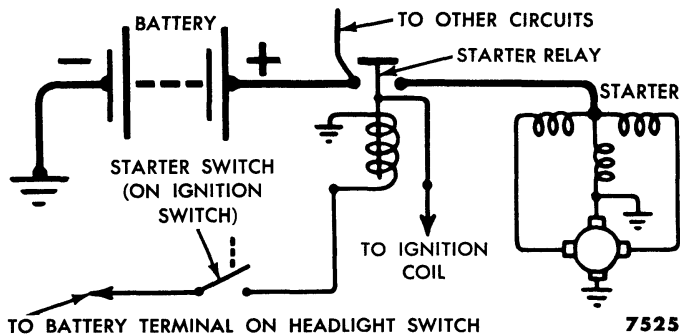

Fig. 1—Starting Circuit Schematic

switch, in the starter control circuit (fig. 2), which prevents operation of the starter if the selector lever is not in the N (neutral) position.

In most cases of starting difficulty, the trouble may be divided into three symptoms: the engine will crank but will not start; the engine cranks slowly; and the engine will not crank.

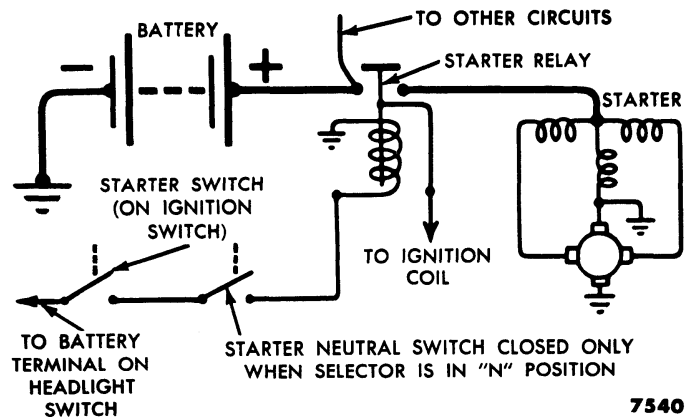

Fig. 2—Automatic Transmission Starting Circuit

1. TROUBLE SHOOTING

If the engine cranks but will not start, the trouble is in the engine (fuel, ignition, engine parts) and not in the starting system. If the engine will not crank even with a booster battery connected, engine parts may be seized or the starter may be faulty. If the engine cranks but cannot be started with a booster battery connected, attempt to start it by pushing the vehicle. If it still will not start, push or tow the vehicle to the shop for a complete diagnosis.

CAUTION: *Do not push or tow a vehicle equipped with Fordomatic for more than 12 miles, without raising the rear wheels off the ground, or disconnecting the driveshaft.*

Table 1 lists three symptoms of starting system dif-

ficulty and troubles that can cause the symptoms. The order of the numbers in each symptom column indicates either the most probable cause of the symptom or the cause which is easiest to eliminate by testing.

The trouble shooting table presents more detailed information on the various causes of the symptom than the "road map" (figs. 3 or 4). The "road map" groups several of these details into a single test; however, the results of the test will indicate the particular trouble causing the symptoms.

Be sure to follow these procedures carefully. Once the method and steps are fixed in your mind you will not have to re-read them on each job. Eventually, the "road map" type illustration will be all that you need.

a. Engine Will Not Crank When Ignition Switch Is Operated.

This symptom may be caused by any one of the following:

The battery may be discharged. The ignition switch or starter relay may be inoperative. The circuit may be open or contain high resistance. Water may have leaked into the cylinders causing a hydrostatic lock. The starter drive may be locked. The starter itself may be faulty or inoperative. The engine may be seized. Figure 3 illustrates the "road map" for the symptom.

(1) **CHECK BATTERY.** Test the state of charge of the battery. If the battery is discharged, follow (a). If the battery is charged, follow (b).

(a) **BATTERY DISCHARGED.** Make a "Battery Capacity Test." If the battery tests good, recharge the battery. If the battery does not test good, make a "Battery Test Charge." Replace the battery if the test indicates that it is worn out or under capacity.

(b) **BATTERY CHARGED.** If the battery is charged, operate the starter to crank the engine. If the engine will not crank and the relay does not click, see (1). If the relay clicks, see (2). If the starter motor spins but will not crank the engine, see "b. Starter Spins But Does Not Crank Engine." On the following two checks, dis-

connect the high tension lead from the spark coil so that the engine cannot start:

(1) **RELAY DOES NOT CLICK.** Connect a jumper from the battery terminal of the relay to the ignition switch terminal of the relay, fig. 5, connection marked ①. If the engine does not crank, the starter relay is probably at fault. If the engine cranks, connect a jumper from the battery terminal on the lighting switch to the (ST) starter relay terminal of the ignition switch, fig. 5, con-

Table 1—Starting System—Causes of Trouble

CAUSES	SYMPTOMS		
	a.	b.	c.
	Engine Will Not Crank	Starter Spins But Will Not Crank Engine	Engine Cranks Slowly
Battery Low in Charge	1		2
Battery Worn Out	2		3
Excessive Circuit Resistance	5		4
Worn Starter Brushes	6		6
Dirty Starter Commutator	7		7
Open or Short Circuit Starter Windings	8		8
Excessive Engine Friction	11		9
Dirty Starter Drive		1	
Starter Drive Broken or Worn		2	
Improper Viscosity Engine Oil			1
Locked Starter Drive	10		
Ignition Switch Faulty	3		
Starter Relay Inoperative	4		
High Resistance in Relay Contacts			5
Hydrostatic Lock	9		

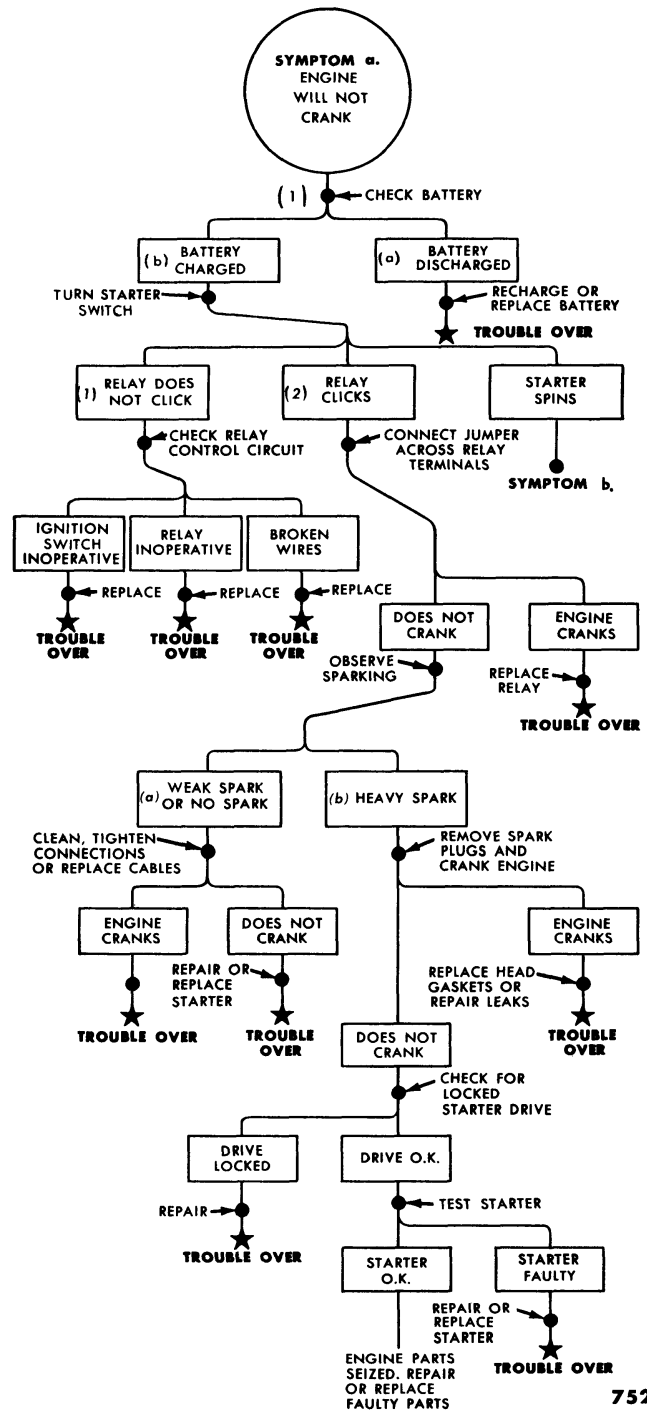

Fig. 3—Engine Will Not Crank—"Road Map"

nection marked ②. If the engine does not crank, the wire connecting the starter relay to the ignition switch, or the wiring connecting the battery to the lighting switch is defective. If the engine cranks, connect the jumper between the lighting switch battery terminal and the "AM" terminal of the ignition switch, fig. 5, connection marked ④. If the engine does not crank when the ignition switch is operated, the ignition switch is at fault. Replace the switch. If the engine cranks when the ignition switch is operated, the wire connecting the ignition switch to the battery terminal on the lighting switch is at fault. Replace the wire.

(2) **RELAY CLICKS.** If the relay clicks when the ignition switch is operated, connect a heavy jumper from the relay battery terminal to the relay starter motor terminal, fig. 5, connection marked ③. If the engine cranks, replace the relay. If the engine does not crank, observe the spark when connecting and disconnecting the jumper. If there is a heavy spark, see (b) below. If the spark is weak or if there is no spark at all, proceed as follows:

(a) **Weak Spark.** If the spark at the relay is weak when the jumper is connected, inspect the battery-starter cables for corrosion and broken conductors. Check the ground cable to see if it is broken or badly corroded. Inspect all cable connections. Clean and tighten them if necessary. Replace any broken or frayed cables. If the engine still will not crank, the trouble is in the starter motor, and it must be repaired or replaced.

(b) **Heavy Spark.** If a heavy spark is obtained when the jumper wire is connected, remove all the spark plugs, and attempt to crank the engine with the starting motor.

If the engine cranks with the spark plugs removed, water has probably leaked into the cylinders causing a hydrostatic lock. The cylinder heads must be removed, and the cause of internal coolant leakage eliminated.

If the engine will not crank, rock the vehicle back and forth with the transmission in high gear, or in case of a Fordomatic transmission loosen the starter mounting bolts to free the starter pinion. If the starter drive is locked, remove the starter from the engine, and examine the starter drive pinion for burred or worn teeth. Examine the teeth on the flywheel ring gear for burrs and wear. Replace the pinion or the flywheel ring gear if they are worn or damaged.

If the starter drive is not locked, remove the starter from the engine, and perform the no-load current test. The motor should run freely. Compare the reading obtained from the ammeter with the no-load current draw specification for the starter. If the current reading and no load speed are below specifications, the starter has high resistance and should be repaired. If the current reading is above normal, and the starter is running

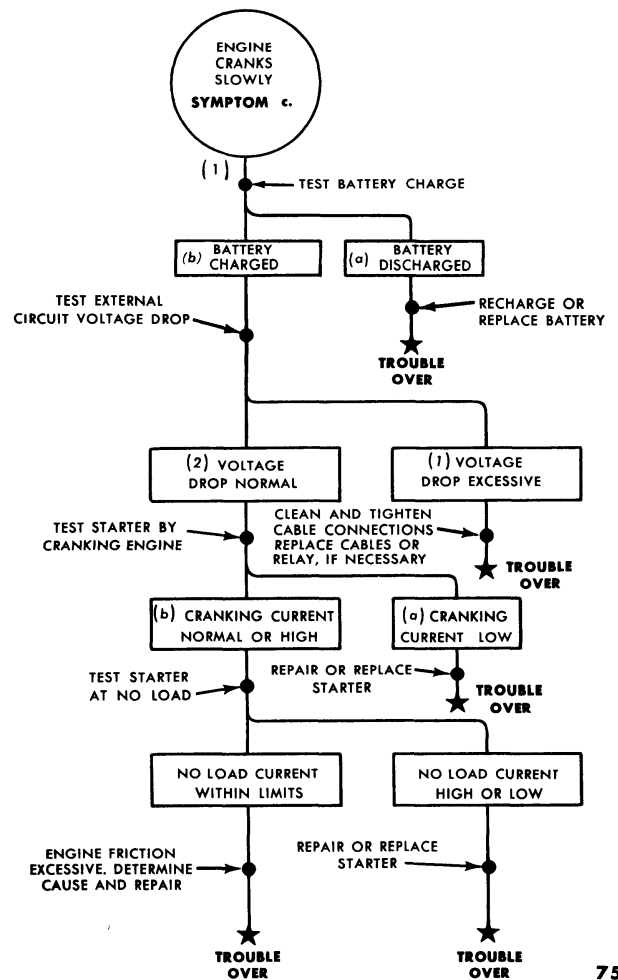

Fig. 4—Engine Cranks Slowly—"Road Map"

slower than it should at no load, it is probably due to tight or defective bearings, a bent shaft, or the armature rubbing the field poles. A shorted coil in the starter also causes the current reading to be high. Disassemble the starter and determine the cause. Repair if possible, or replace the starter.

If the no-load current reading of the starter is normal, the engine is seized and cannot be turned by the starter.

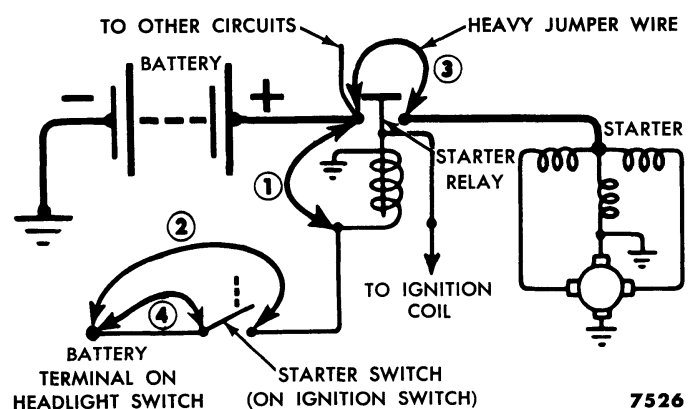

Fig. 5—Starting Circuit Test

Disassemble the engine and repair or replace the defective parts.

b. Starter Spins But Does Not Crank the Engine.

If the starter spins but will not crank the engine, the starter drive is dirty or worn and is sticking on the starter shaft.

Remove the starter from the engine, and remove the starter drive. Clean the starter drive parts in kerosene. Replace worn or damaged parts as required. Assemble the starter drive, and mount the starter on the engine.

CAUTION: *Do not use oil to lubricate the starter drive. It should work freely when cleaned in kerosene.*

c. Engine Cranks Slowly.

Several causes may result in this symptom; the battery may be low in charge; there may be excessive resistance in the starter circuit; the starter may be faulty; the engine may have excessive friction.

Figure 4 shows the "road map" for this symptom.

(1) **TEST BATTERY CHARGE.** Test the state of charge of the battery. If the battery is low in charge, follow (a). If the battery is fully charged, follow (b).

(a) **BATTERY DISCHARGED.** Make a "Battery Capacity Test." If the battery tests good, recharge the battery. If the battery does not test good, make a "Battery Test Charge." Replace the battery if the test indicates it to be worn out or under capacity.

(b) **BATTERY CHARGED.** If the battery is charged, test the external circuit voltage drop. If the voltage drop is excessive, follow (1) "Voltage Drop Excessive." If the voltage drop is normal, follow (2) "Voltage Drop Normal."

(1) **VOLTAGE DROP (RESISTANCE) EXCESSIVE.** If the voltage drop (resistance) is greater than that specified,

locate the exact part of the circuit with the excessive resistance.

If the resistance is in the battery-to-starter-relay-cable, clean and tighten the cable connections. Recheck the voltage drop. If it is still excessive, replace the cable. If the resistance of the starter relay contacts is excessive, replace the starter relay.

If the resistance is in the starter-relay-to-starter-motor cable, clean and tighten the cable connections. Recheck voltage drop. If excessive, replace the cable.

If the resistance is in the battery-to-ground cable, clean and tighten the cable connections. Recheck the voltage drop. If it is still excessive, replace the cable.

NOTE: *Some vehicles have a bonding strap as part of the ground circuit which must not be overlooked.*

(2) **VOLTAGE DROP (RESISTANCE) NORMAL.** If the voltage drop (resistance) is normal, test the starter current draw while the starter is cranking the engine. If the current draw is normal or excessive, see (b) below. If the starter current is low (normal 140-190 amperes), proceed as follows:

(a) **Cranking Current Low.** Remove the starter from the engine, and disassemble it. Determine the cause of the trouble, and correct it if possible. If not, replace the faulty part, assemble the starter, and mount it on the engine.

(b) **Cranking Current Normal or High.** Test the starter current draw at no-load. If the current draw is above or below specifications, remove the starter from the engine, and disassemble it. Determine the cause of the trouble, and correct it if possible. If not, replace the faulty part, assemble the starter, and mount it on the engine.

If the current draw at no load is normal, the starter is OK. The engine has excessive friction, and the cause must be determined. Repair or replace faulty parts.

2. STARTER AND CIRCUIT

Heavy cables, connectors, and switches are used in the starting system because of the high current required by the starter while it is cranking the engine. The amount of resistance in the starting circuit must be kept to an absolute minimum to provide maximum current for starter operation. Loose connections, corroded relay contacts, and partially broken cables will result in slower than normal cranking speed, and may even prevent the starter from cranking the engine.

The starter is a four-brush, series-parallel wound unit. The circuit to the starter is completed by means of a relay controlled by a switch which is part of the

ignition switch mounted on the instrument panel. The return circuit is through the starter housing, engine block, and battery ground cable to the battery.

Figure 6 shows the starter mounted on an 8-cylinder engine equipped with Fordomatic drive. Figure 7 shows the starter mounted on a 6-cylinder engine.

a. Starter and Circuit Tests.

Five different tests of the starter and its circuit are described under headings that indicate the nature of the test. The arrangement of these tests is not intended to indicate an order of procedure. The selection of the test

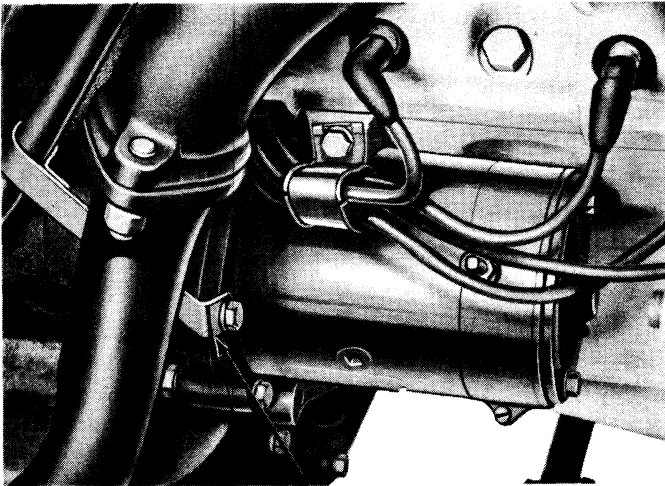

DIPSTICK SUPPORT BRACKET

3761

Fig. 6—Starter Mounting—8-Cylinder

to be made is controlled by the circumstances encountered, usually as a result of analyzing troubles as covered in trouble shooting, or as a part of a preventive maintenance plan. The following units will be needed to perform the test procedures:

- 0-1 } Voltmeter
- 0-20 } Voltmeter
- 0-50 } Ammeter
- 0-300 } Ammeter

Carbon pile rheostat (heavy duty)

Assorted connecting wires and jumper wires equipped with suitable connectors.

(1) **STARTER LOAD TEST.** When this test is performed in conjunction with the "Starter No-Load Test," it will determine if the starter is faulty or if the engine

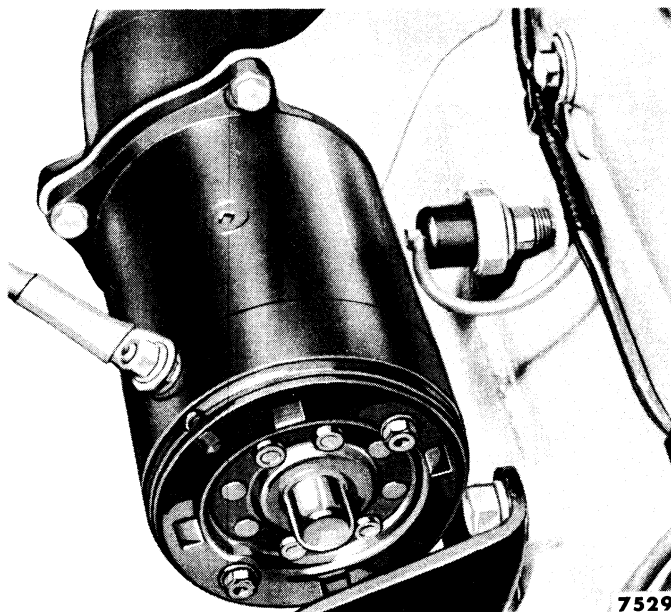

7529

Fig. 7—Starter Mounting—6-Cylinder

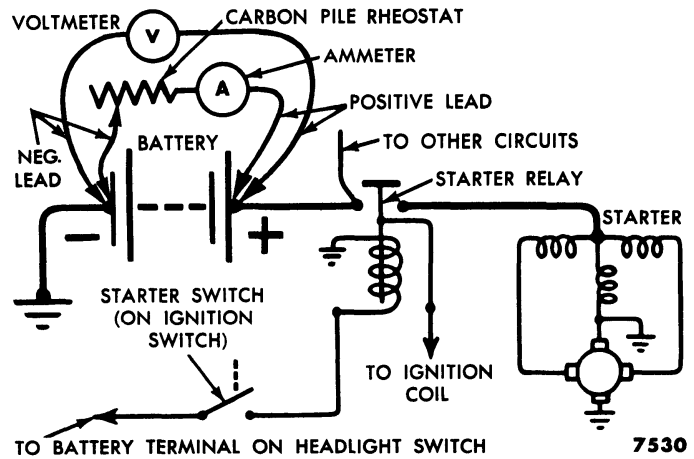

Fig. 8—Starter Load Test—Schematic

has excessive friction.

Connect the test equipment as shown in figs. 8 or 9. Be sure that no current is flowing through the ammeter and carbon pile rheostat portion of the circuit (rheostat at maximum resistance). Crank the engine with the ignition OFF, and determine the exact reading on the voltmeter.

NOTE: This test is accomplished by disconnecting the high tension lead from the spark coil, and by connecting a jumper from the battery terminal of the starter relay to the ignition switch terminal of the relay.

Stop cranking the engine, and reduce the resistance of the carbon pile until the voltmeter indicates the same reading as that obtained while the starter cranked the engine. The ammeter will indicate the starter current draw under load. This reading should be a maximum of 190 amperes with the engine at normal operating temperature.

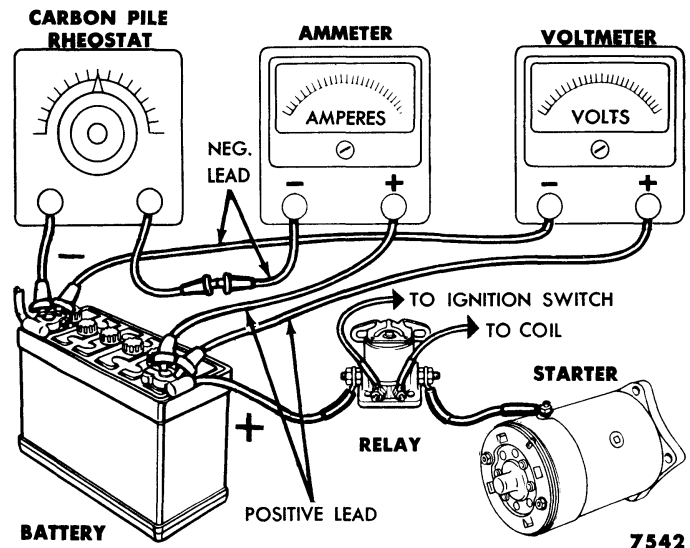

Fig. 9—Starter Load Test—Pictorial

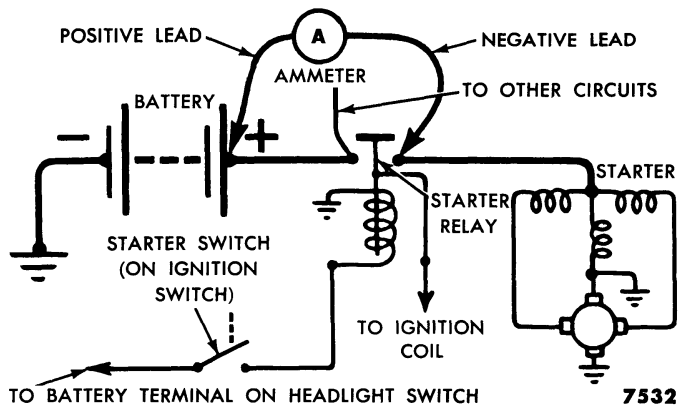

Fig. 10—Starter No-Load Test—Schematic

(2) **STARTER NO-LOAD TEST.** This test will uncover such faults as open or shorted windings, rubbing armature, and bent armature shaft. The starter can be tested, at no-load, either on the engine or test bench.

(a) **ON ENGINE.** To test the starter, the engine must be running at idle speed to prevent the starter drive from engaging the flywheel. With the engine idling, make the ammeter connections as shown in figs. 10 or 11. The no-load current draw on the ammeter should be 120 amperes.

(b) **ON TEST BENCH.** Connect the starter to a battery with an ammeter in the circuit as shown in fig. 12. The starter will run at no-load, and the current draw indicated on the ammeter should be 120 amperes.

(3) **ARMATURE AND FIELD OPEN CIRCUIT TEST—TEST BENCH ONLY.** An open circuit armature may sometimes be detected by examining the commutator for evidence of burning. The spot burned on the commutator is caused by an arc formed every time the commutator segment connected to the open-circuit winding passes under a brush.

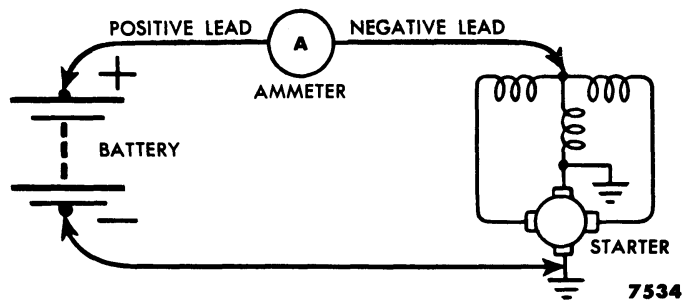

Fig. 12—Starter No-Load Test—On Test Bench

An open circuit test of the field can be made on the test bench by connecting a voltmeter and battery as shown in fig. 13. Since the starter has three field windings, it will be necessary to check each of the windings separately. If no voltmeter reading is obtained, the coil is open.

(4) **ARMATURE AND FIELD GROUNDED CIRCUIT TEST—TEST BENCH ONLY.** This test will determine if the winding insulation has failed, permitting a conductor to touch the frame or armature core.

To determine if the armature windings are grounded, make the connections as shown in fig. 14. If the voltmeter indicates any voltage, the windings are grounded.

Grounded field windings can be detected by making the connections as shown in fig. 15. If the voltmeter indicates any voltage, the field windings are grounded.

(5) **STARTER CIRCUIT TEST.** Excessive resistance in the starter circuit can be determined from the results of this test. Make the test connections as shown in figs. 16 or 17. Crank the engine with the ignition OFF.

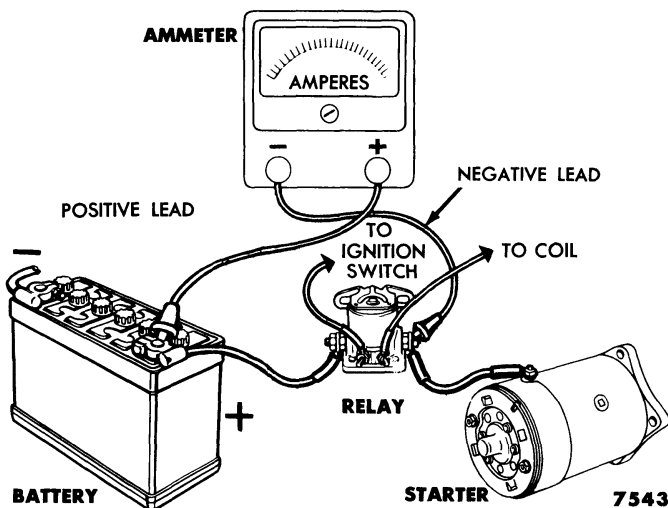

Fig. 11—Starter No-Load Test—Pictorial

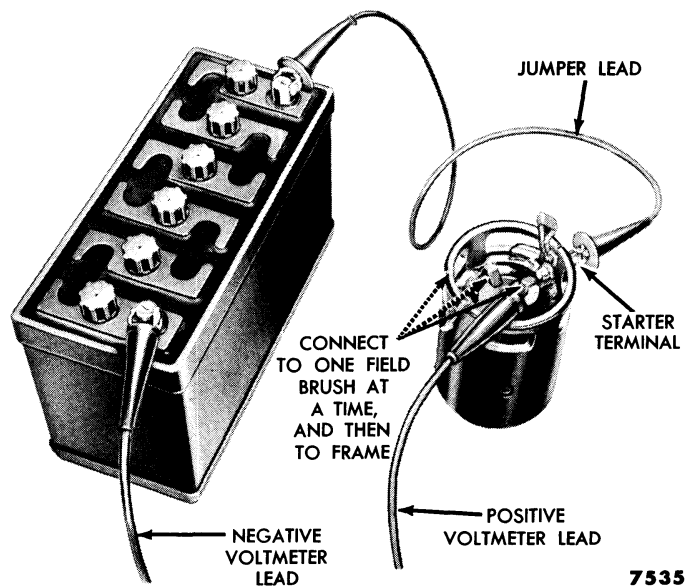

Fig. 13—Open Circuit Test of Field

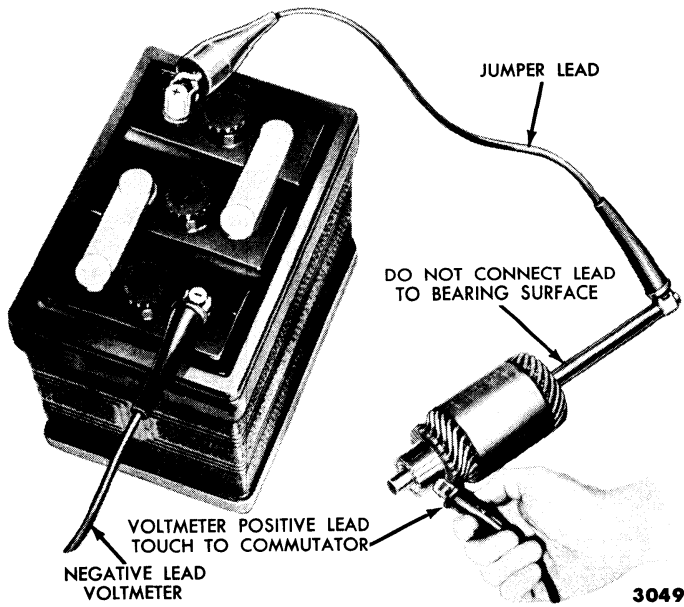

Fig. 14—Grounded Circuit Armature Test

NOTE: This test is accomplished by disconnecting the high tension lead from the spark coil and by connecting a jumper from the battery terminal of the starter relay to the ignition switch terminal of the relay.

The voltage drop in the circuit will be indicated by the voltmeter. Maximum allowable voltage drop should be:

- Connections marked ① 0.5 volt
- Connections marked ② 0.1 volt
- Connections marked ③ 0.3 volt
- Connections marked ④ 0.1 volt

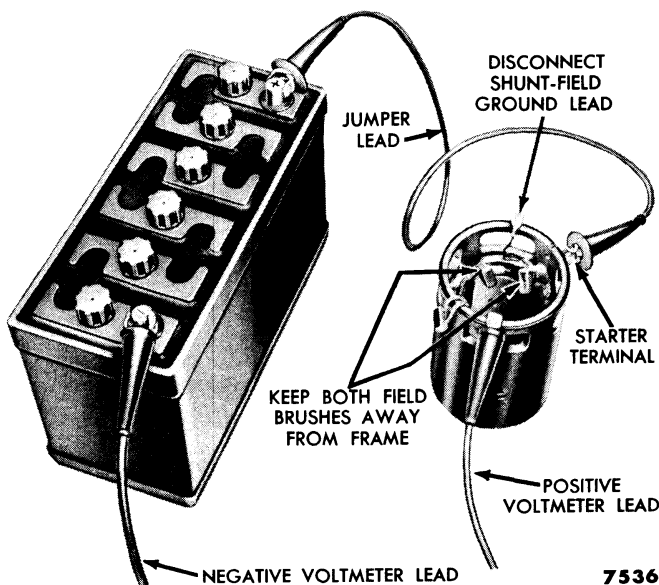

Fig. 15—Grounded Circuit Test of Field

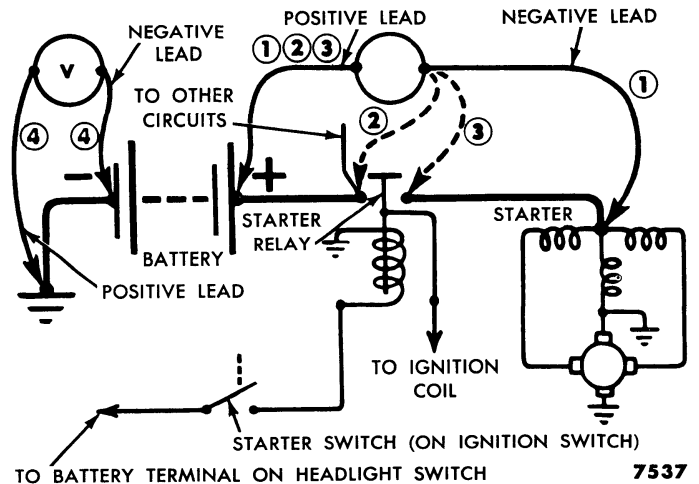

Fig. 16—Starter Circuit Test—Schematic

b. Starter Repair.

In many cases it will not be necessary to completely disassemble the starter to accomplish repair or replacement of certain parts. Paragraphs "(3) Armature Replacement," "(4) Commutator Turning," and "(5) Brush Replacement," below, are procedures which eliminate the steps in disassembly that do not apply to these particular operations.

(1) **REMOVAL AND INSTALLATION.** Disconnect the starter cable at the starter terminal, remove the clutch housing to starter screws, then remove the starter assembly.

NOTE: It may be necessary to tilt the starter slightly to clear the starter drive around the flywheel.

When installing the starter, assemble the motor to the engine. Install the clutch housing to starter screws. On trucks equipped with Fordomatic, the Fordomatic

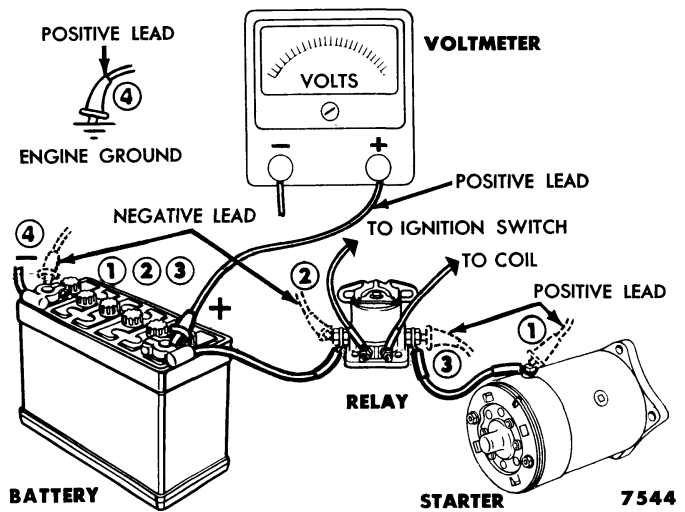
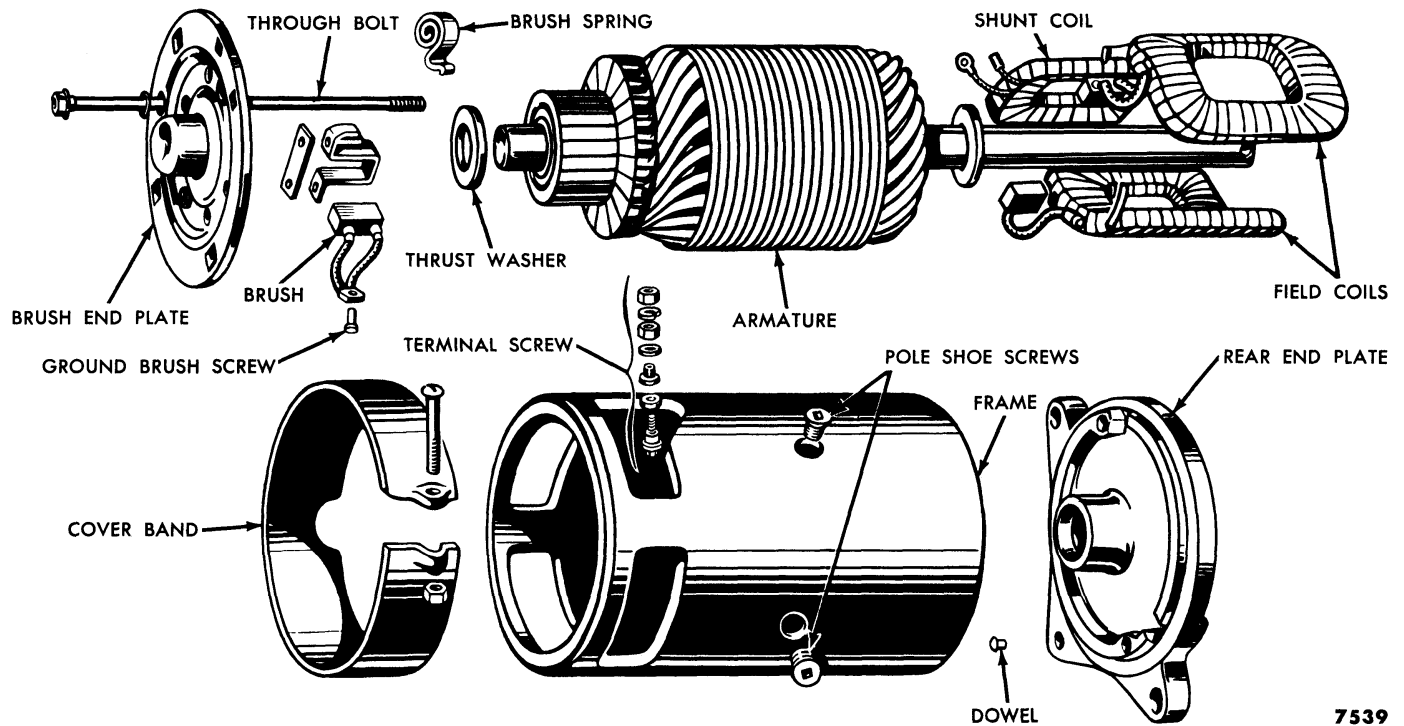

Fig. 17—Starter Circuit Test—Pictorial



7539

Fig. 18—Starter Motor—Disassembled

dipstick tube bracket is mounted under the starter side mounting bolt.

On 8-cylinder engines, make certain that the rubber seal is properly positioned before mounting the starter. If trouble is encountered in keeping the seal in position, apply rubber cement to both the seal and the engine block to hold the seal in position while mounting the starter.

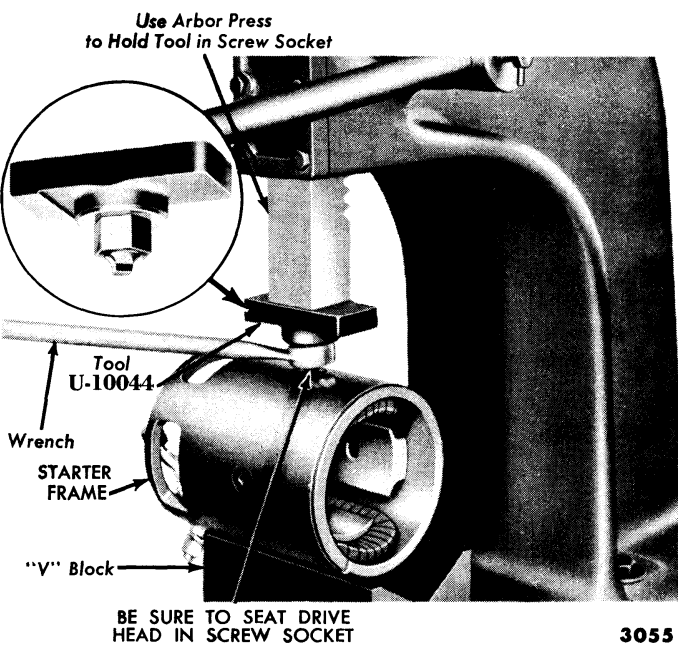

3055

Fig. 19—Pole Shoe Screw Removal

(2) **COMPLETE DISASSEMBLY.** Use the following procedure when it becomes necessary to completely overhaul the starter. Figure 18 illustrates the starter completely disassembled.

(a) **DISASSEMBLY.** Remove the starter drive, through bolts, and rear end plate (fig. 18). Be sure to remove all burrs from the shaft to prevent scoring the rear end plate bushing. Remove the armature. Remove the cover band.

Remove the brushes from their holders, and remove the brush end plate. Unscrew the ground brush screws, and remove the ground brushes. Unscrew the three field-pole-shoe screws as shown in fig. 19. The arbor press prevents the wrench from slipping out of the screw.

Unsolder the field coil leads from the terminal screw, and remove the pole shoes and field coils from the frame. Remove the nut and washers from the terminal and remove the terminal. Remove any excess solder from the terminal slot.

NOTE: Use a 300-watt soldering iron for soldering operations on the starter terminal.

(b) **CLEANING AND INSPECTION.** Wipe the field coils, armature, commutator, and armature shaft with a clean cloth. Wash all other parts in solvent and dry the parts.

Inspect the armature windings for broken or burned insulation and unsoldered connections. Check the arma-

ture for open circuits and grounds. Check the commutator for runout (fig. 20). Inspect the armature shaft and the two bearings for scoring and excessive wear. Check the brush holders for broken springs and the insulated brush holders for shorts to ground. Check the brush spring tension. It should be 48-56 ounces. Replace the springs if the tension is not within limits. Inspect the field coils for burned or broken insulation. Check the field brush solder connections and lead insulation.

(c) **ASSEMBLY.** Install the terminal screw with insulator washers and terminal nut. Be sure to position the slot in the screw parallel to the frame end surface. Solder the leads to the terminal using rosin core solder.

NOTE: *As the pole shoe screws are tightened, strike the frame several sharp blows with a soft-faced hammer to seat and align the pole shoes.*

Position the shunt coil ground lug under the ground brush terminal closest to the starter terminal. Install the screws that connect the ground brushes to the starter frame. Install the brush end plate making sure that the brush-plate boss is located in the slot in the starter frame.

CAUTION: *Do not pinch the brush leads between the end plate and the frame.*

Place a thrust washer on each end of the shaft, slide the armature in place, and install the rear end plate with the end plate dowel located in the starter frame slot. Install the through-bolts. Install the brushes in their holders being sure to center the brush springs on the brushes. Place the cover band on the starter, and tighten the clamp screw.

(3) **ARMATURE REPLACEMENT.** Remove the starter drive, through-bolts, rear end plate, and cover band. Be sure to remove all burrs from the shaft to prevent scoring the rear end plate bushing. Remove the armature.

Before installing the new armature, pull the brushes from their holders. Slide in the armature, and install the rear end plate and through bolts.

NOTE: *The end plate dowel must be aligned with the slot in the starter frame.*

Replace the brushes in their holders, and center the brush springs on the brushes. Install the starter drive.

(4) **COMMUTATOR TURNING.** Check the commutator runout as shown in fig. 20. If the surface of the commutator is rough or more than 0.002 inch out-of-round, turn it down in a lathe or with a turning tool, (fig. 21).

Polish the commutator with 00 or 000 sandpaper to remove all burrs left by the turning operation. Be sure

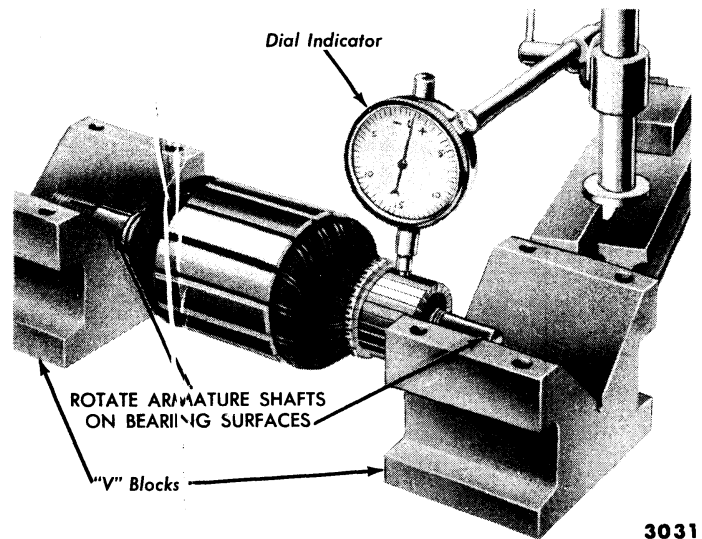

Fig. 20—Commutator Runout Check

that no copper particles remain on the insulation between the segments.

NOTE: *It is not necessary to undercut the mica on the starter motor commutator.*

(5) **BRUSH REPLACEMENT.** Replace the starter brushes when they are worn to $\frac{5}{16}$ inch in length. Always install a complete set of new brushes.

Loosen and remove the cover band. Remove the two through bolts from the starter frame. Remove the brushes from their holders. Remove the brush-end plate and the armature rear end plate assembly. Unsolder the brush leads from the field coils. Unscrew the ground brush terminal screws, and remove the ground brushes.

Clean the carbon and dirt from the brush end plate. Replace the brush end plate if the insulation between the field brush holder and the end plate is cracked or

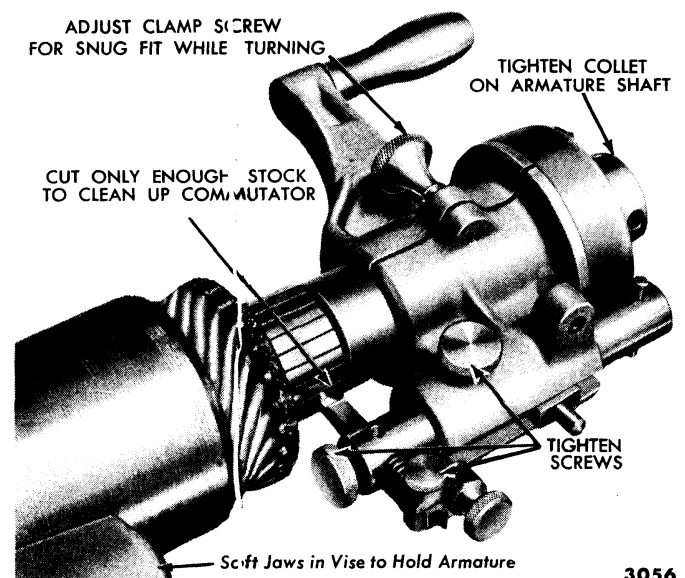

Fig. 21—Starter Commutator Turning

3031

3056

broken. Make sure that the new brushes slide freely in the holders. Seat the new brushes by sanding (fig. 22).

Solder the new field brushes to the field coils. Position the shunt coil ground lug under the ground brush terminal closest to the starter terminal. Connect the new ground brushes to the starter frame with the terminal screws. Install the brush end plate. Slide the armature rear end plate assembly in place.

3. STARTER DRIVE

The starter drive is the "Folo-Thru" type shown in fig. 23.

NOTE: *The "Folo-Thru" drive is serviced only as a complete unit, because of the calibration requirements on the lock pin and anti-drift pin springs.*

a. Removal and Installation.

To remove the "Folo-Thru" drive, compress the spring until the end anchor plate clears the drive pin. Remove the drive pin. Slide the drive assembly off the shaft.

To install the drive assembly, line up the pin hole with the hole in the shaft. Compress the spring enough to allow insertion of the drive pin. Insert the pin. The anchor plate covers up the pin holes and prevents the pin from coming out.

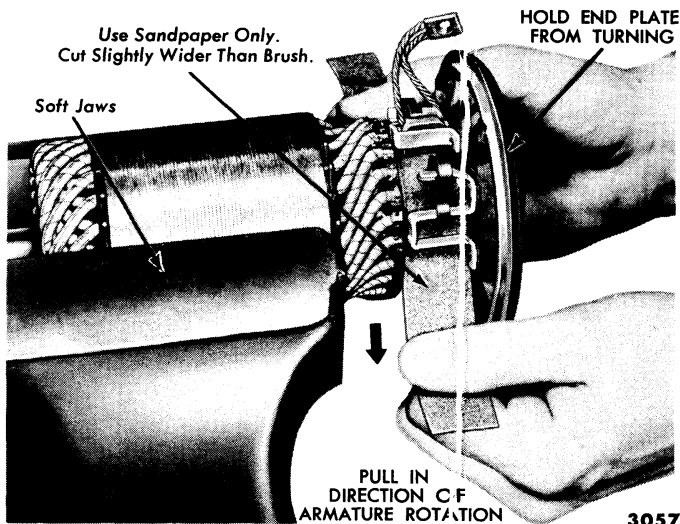

Fig. 22—Starter Motor Brush Seating

NOTE: *Make sure that the locating boss in the brush-end plate and the dowel in the rear-end plate are located in the slots in the starter frame.*

Replace the two through-bolts in the starter end plates. Place the brushes in their holders. Be sure to center the brush springs on the brushes. Install the cover band and tighten the clamp screw.

b. Cleaning and Inspection.

A sticking starter drive can be cleaned in kerosene. Use a brush to remove grease and dirt from the worm threads until all grit is removed.

CAUTION: *The "Folo-Thru" drive has a lock pin which holds the pinion from rotating when it is in the extended position. Once the pin has dropped into place, it will not disengage unless the starter is mounted on the car and the engine speed reaches 310-390 r.p.m. It cannot be forced out of position by hand.*

Do not oil the starter drive. It should work freely after cleaning in kerosene.

Inspect the pinion for burrs and broken or badly worn teeth. Check the action of the pinion on the worm threads. It should slide freely on the threads. Check the drive spring to see if it is cracked, broken, or the end tangs are bent. If any of the pinion teeth are badly worn, burred or broken, it will be necessary to replace the drive.

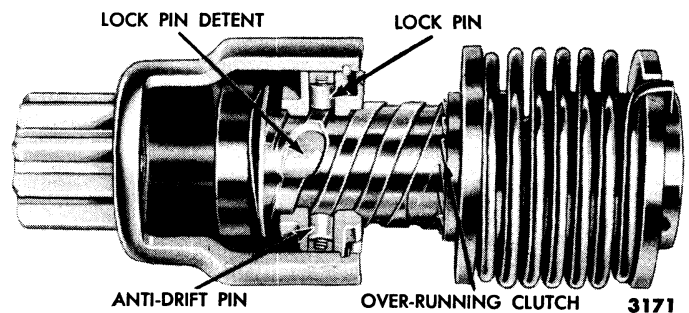

Fig. 23—"Folo-Thru" Starter Drive

Part THREE

ELECTRICAL AND ACCESSORIES

Chapter

III

Lighting System, Horns, and Instruments

Section	Page
1 Trouble Shooting	245
2 Lighting System	247
3 Horns	252
4 Instruments	253

Information on trouble shooting, tests, adjustments, and repair of the lighting system, horns, and instruments is contained in this chapter.

Wiring diagrams are given, showing the color coding and sizes of the various wires.

I. TROUBLE SHOOTING

The first step in trouble shooting is to establish the facts, making the necessary correction where a fault is found before proceeding with the next step.

A quick analysis of the entire electrical system to isolate individual circuits causing trouble is made by determining if current is available at various points in the main circuit. These tests are made as follows: Press the horn button (momentarily). Operate the starter switch (momentarily). Turn the ignition switch on (15 seconds). Turn the dome light on (momentarily). Turn on the headlights (momentarily).

Based on observations made during the above tests, the following diagnosis can be made:

If the horn sounds, the battery, horn relay and the battery cables are probably OK.

If the horn does not sound and if the starter engages, instruments register, and the lights light, the trouble is in the horn circuit. Follow symptom "d. Horn Does Not Sound."

If the starter engages, and cranks the engine, the battery cables, and starter relay are OK.

If the starter does not engage, but the horn does sound, the starting system is at fault.

If the instruments register, the battery, cables, and circuit to the lighting switch are OK.

If none of the instruments register and the lights do not light, the trouble is in the wire running from the starter relay to the lighting switch. If none of the instruments register but the lights light, the trouble is in the ignition switch or main feed wire to the instruments.

If some but not all of the instruments register, follow the procedure that applies under f. through h. below.

If the dome light lights, the interior light fuse and wiring to the dome light is OK.

If the headlights light, the battery, cables, circuit to the overload circuit breaker (part of lighting switch), and the circuit breaker are OK.

If the headlights do not light, the battery cable is loose, the main feed wire is disconnected at the switch or is broken, the headlight beam control switch is defective, or the headlights are burned out.

a. Both Headlights Do Not Light.

If both headlights do not light, the overload circuit breaker may be operating as a result of a grounded wire in the headlight circuit, both lights are burned out, or there is a broken wire. Set the headlight switch to the headlight position. Observe the reaction as you switch from high to low beam with the beam control switch.

If the lights light only when the beam control switch is in the upper beam position, the trouble is in the lower beam circuit from the beam control switch to the headlights. If the lights light only when the beam control switch is in the lower beam position, the trouble is in the lower beam circuit from the beam control switch to the headlights. If the lights are out in both high and low beam, the trouble is probably in the beam control switch or the wire supplying the switch.

Connect a jumper from the positive battery terminal to the headlight supply wire at the left fender apron

terminal block (high beam; green-black band, low beam; red-black band) after first disconnecting the wire. If the headlights now light, there is an open or grounded circuit from the terminal block to the lighting switch. Repair or replace parts as required. If the headlights do not light they are probably both burned out. Check by replacing with new headlights.

b. Individual Lights Do Not Light.

When one or several lights do not light and other lights do, the fault usually is in the bulb itself. If the bulb is readily accessible, replace the bulb. If the bulb is in an inaccessible position, make the following test:

Turn the lights on. Check for voltage at the bullet connector nearest to the bulb, with a voltmeter. If voltage is available, replace the bulb or any wiring that runs from that point to the bulb. If no voltage is available, an open or grounded circuit exists between the point that was checked and the light switch. Make necessary repairs.

c. One or More Lights Burn Out Repeatedly.

Lights burn out prematurely because of high voltage, loose or corroded connections, or excessive vibration.

Clean and tighten all electrical connections in the circuit involved, including the battery cable connections. Test the generator voltage regulation, and adjust or replace the regulator if required.

d. Horn Does Not Sound.

In some cases the horn may have been disconnected by someone without the owner's knowledge. Reconnect any wires that may have been disconnected at either the horn relay or the bottom of the steering column. If the horn sounds when connecting the wires, follow the procedure outlined in "e. Horn Sounds Continuously." If the horn does not sound when all the wires are connected, press the horn button. If the horn still does not sound, check for voltage at the main feed wire at the horn relay. If voltage is available, the wire can be considered satisfactory. Connect one end of a jumper wire to the main feed wire. Momentarily contact the other end of the jumper wire to each horn wire. If each horn sounds, replace the horn relay. If the horns do not sound, repair or replace the horns.

If no spark occurs, an open circuit exists between the end of the wire that was grounded and the starter relay. Repair the wire.

e. Horn Sounds Continuously.

To stop the horn from sounding, disconnect the horn

button wire from the bullet connection at the lower end of the steering column or at the horn relay, whichever is more accessible. If the horn continues to sound, disconnect the horn wire from the horn relay.

If the horn stops sounding when the horn button wire is disconnected, repair or replace the horn button wire or horn button. If the horn continues to sound after the horn button wire is disconnected, the trouble is in the relay or the wire between the bullet connection and the relay. Repair the wire or replace the relay.

f. Charge Indicator Light Inoperative.

Turn the ignition switch on. If the charge indicator light does not come on when the ignition switch is first turned on, the light bulb may be burned out, or the wiring from the light socket to the rest of the circuit may be defective.

Remove the bulb. If the light bulb is not burned out, turn the ignition switch on, but do not start the engine. Check for voltage at the light socket as follows:

Connect a voltmeter from the center contact (black wire with green band) to ground. The meter should indicate 12 volts. If the meter shows no voltage, connect it from the "AM" or "BAT" terminal of the ignition switch to ground. If voltage is available here, the ignition switch to charge indicator light socket wire is defective. Replace the wire. If no voltage is available at the gauge terminal of the ignition switch, the ignition switch or its wiring is defective. Check and replace where necessary.

If voltage is indicated at the light socket, and the light does not operate, check the yellow wire with black band that leads from the light socket to the armature terminal of the voltage regulator. Replace the wire if necessary.

g. Fuel Gauge Reads Falsely.

The amount of fuel in the tank does not affect the following test procedures. Turn the ignition switch ON, check for voltage at the gauge feed wire, and observe the fuel gauge. Follow (1) or (2), whichever applies.

(1) **GAUGE READS OVER THE FULL MARK CONTINUOUSLY OR READS ERRATICALLY.** If the indicator hand goes beyond the scale on the opposite side of the gauge or reads erratically, a wire in the fuel gauge circuit is grounded or the tank unit is defective. Determine whether the wire or the tank unit is at fault and repair or replace the defective item. Check the pointer travel to determine whether or not the gauge has been damaged, by making a gauge unit test.

(2) **GAUGE READS LESS THAN FULL.** If the gauge reads less than full or fails to register, momentarily short the fuel gauge (dash unit) terminal (yellow) wire to ground with a jumper wire until the needle reaches the highest reading on the gauge, then immediately re-

move the grounded wire. Follow (a) or (b), whichever applies.

WARNING: *Leaving the wire grounded after the maximum reading is obtained may damage the gauge.*

(a) **GAUGE READS FULL.** If the needle reaches the maximum travel on the scale when the wire is grounded, either the fuel tank unit or the wire connecting the fuel tank unit and gauge is at fault. Turn the ignition off, and connect a grounded jumper wire to the sending unit terminal. Turn the ignition switch on momentarily. If the gauge begins to indicate, the tank unit is at fault and must be replaced. If the gauge does not indicate, the connecting wire is broken. Make the necessary repairs.

(b) **GAUGE FAILS TO READ.** If the gauge on the instrument panel does not register when the gauge terminal is grounded, replace the gauge.

h. Oil Pressure Indicator Light Inoperative.

Turn the ignition switch on. If the oil pressure indicator light does not come on when the ignition switch is first turned on, either the bulb is burned out, the oil pressure switch unit is defective, or the connecting wiring is defective.

Check to see if the bulb is burned out. Replace it if necessary.

If the bulb is good, turn the ignition switch on (engine not running), and short the terminal of the oil pressure switch unit to ground. If the light comes on, the switch unit is defective. Replace the unit. If the light does not operate, ground the terminal of the white wire with red band at the light socket. If the light now comes on, the wire from the socket to the switch unit is defective. Replace the wire.

If the light did not come on, test for voltage at the "AM" or "BAT" terminal of the ignition switch. If voltage is available at the switch, the switch to socket wire is defective. Replace the wire.

If no voltage appears at the ignition switch "AM" or "BAT" terminal with the ignition switch on, the switch or its associated wiring is defective. Check and repair

where necessary.

i. Temperature Gauge Reads Falsely.

Turn the ignition switch ON, and observe the temperature gauge (engine should be at normal temperature). Follow (1) or (2) below, whichever applies.

(1) **INDICATOR AT THE "C" POSITION ALL THE TIME.** This symptom indicates a ground in the gauge circuit or a defective dash unit. To check the circuit, proceed as follows:

Disconnect the wire (red with white band) leading to the engine unit at the terminal on the dash unit. Turn on the ignition switch. If the indicator remains at the "C" position, replace the dash unit. If the indicator moves toward the "H" position, a ground exists in the wiring from the dash unit to the sending unit, or the sending unit is defective.

Connect the wire (red with white band) to the dash unit. Disconnect the wire at the sending unit. Do not ground the wire. Turn on the ignition switch. If the indicator remains at the "C" position, a ground exists in the wire. If the indicator moves toward the "H" position, the fault lies in the sending unit. Replace the unit. Check the indicator for damage caused by overheating the bimetallic winding by making a gauge unit test.

(2) **INDICATOR REMAINS AT THE "H" POSITION.** Turn on the ignition switch. Observe the gas and oil pressure indicators. If they are inoperative, correct the power supply circuit from the ignition switch to the dash instruments. If both units are operative, proceed as follows:

Momentarily short to ground, the wire (red with white band), leading from the dash unit to the sending unit, at the dash unit. If the indicator moves toward the "C" position, an open circuit is indicated.

With the ignition switch ON, momentarily short to ground the terminal of the sending unit. If the indicator remains at the "H" position, the wire between the engine sending unit and the gauge is open. Repair or replace the wire. If the indicator moves toward the "C" position, the sending unit is defective. Replace the unit.

2. LIGHTING SYSTEM

The law requires that the lighting system be kept in good operating condition. Certain adjustments can be made, periodically, to keep the lighting system operating at maximum efficiency.

Wiring diagrams are presented in figs. 1 and 2. As-

sembly and disassembly operations are illustrated when it is necessary to show details or changes in procedure.

a. Headlight and Roadlight Alignment.

Two methods are generally used to make a headlight

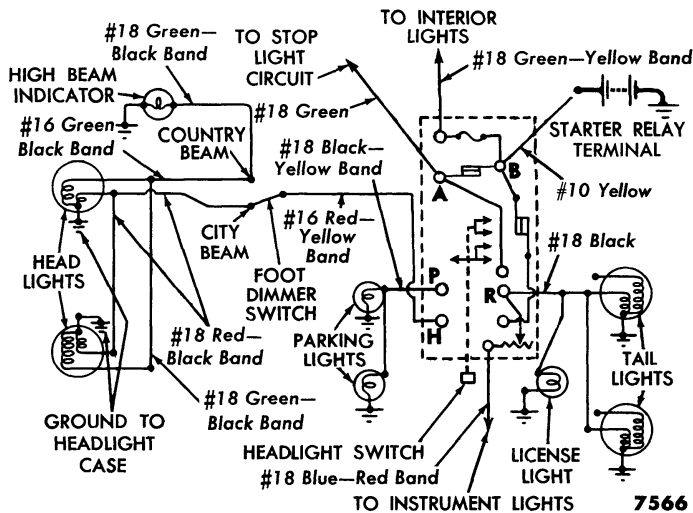

Fig. 1—Headlight Circuit Diagram

or a roadlight alignment. One method is to use special alignment equipment. The other method makes use of a wall screen.

When using special equipment, follow the instructions of the particular manufacturer. The use of the wall screen is described here.

(1) **HEADLIGHT ALIGNMENT.** To align the headlights by means of a wall screen, select a level portion of the shop floor. Lay out the floor and wall as shown in fig. 3.

Establish the headlight horizontal centerline by subtracting 20 inches from the actual height of the headlight lens center from the floor and adding this dimension (dimension "B," fig. 4) to the 20-inch reference line obtained by sighting over the uprights. Draw a

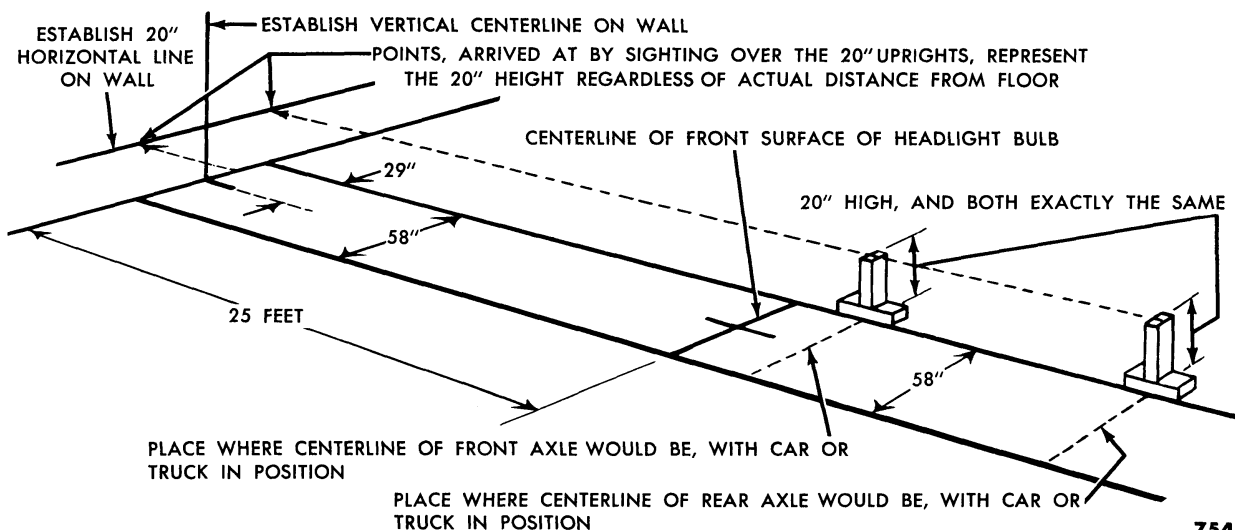

Fig. 3—Floor and Wall Layout

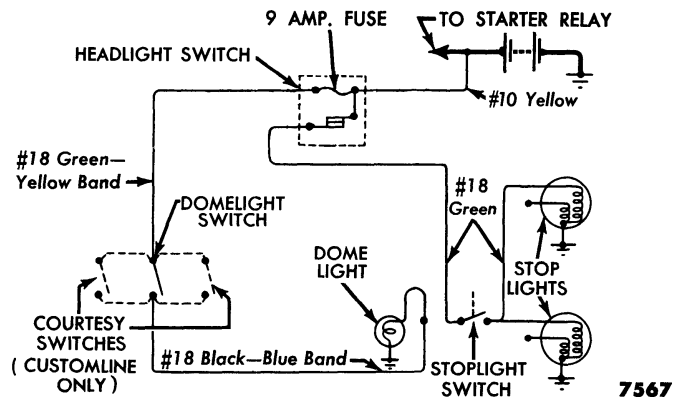

Fig. 2—Domelight and Stoplight Diagram

horizontal line 2 inches below, and parallel to, the headlight horizontal centerline. Then draw the headlight vertical centerlines on the screen (dimension "A," fig. 4). Adjust each headlight beam as shown in fig. 4.

NOTE: *On the Thunderbird, dimension "A" is 57 3/4 inches.*

Each headlight is adjusted by means of two screws located under the headlight trim ring as shown in fig. 5.

NOTE: *Some states do not approve of the 2-inch dimension. Check your state law, as a 3-inch dimension may be required.*

(2) **ROADLIGHT ALIGNMENT.** Roadlights are available on the Thunderbird only. Proper adjustment of roadlights is as important as headlight adjustment if maximum safety is to be achieved.

To align the roadlights by means of a wall screen,

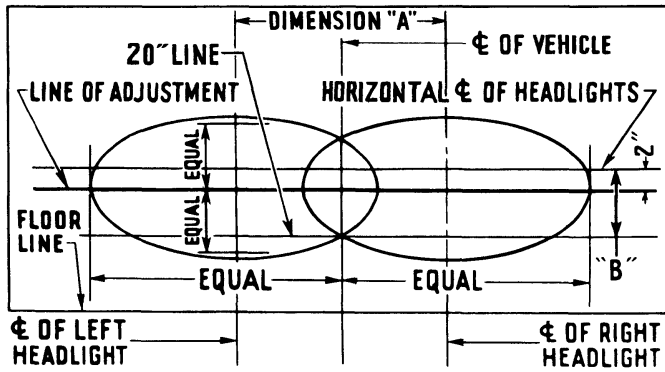

HEADLIGHT 25 FEET FROM WALL
(HIGH BEAM DIAGRAM) 7547

Fig. 4—Headlight Wall Screen

select a level portion of the shop floor. Lay out the floor and wall as shown in fig. 3.

Establish the roadlight horizontal centerline by subtracting 20 inches from the actual height of the roadlight lens center from the floor and adding this dimension (dimension "B," fig. 6) to the 20-inch reference line obtained by sighting over the uprights. Draw a horizontal line 4 inches below, and parallel to, the roadlight centerline. Then draw the roadlight vertical centerlines on the screen (dimension "A," fig. 6, 35 5/8 inches).

NOTE: *The roadlights are mounted inside the bumper guards and are adjusted by vertical and horizontal adjusting screws. The adjusting screws are accessible from the rear of the bumper guards.*

Adjust each roadlight so that the high intensity zone of the light is centered on its vertical centerline and the

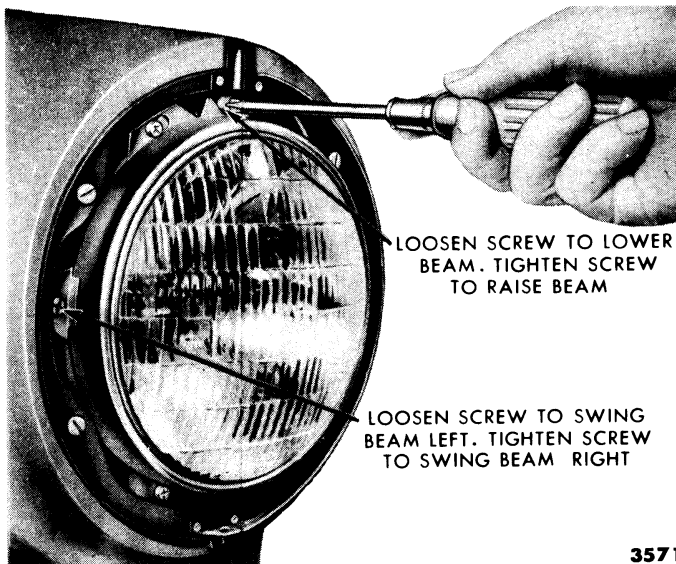

3571

Fig. 5—Headlight Adjustment

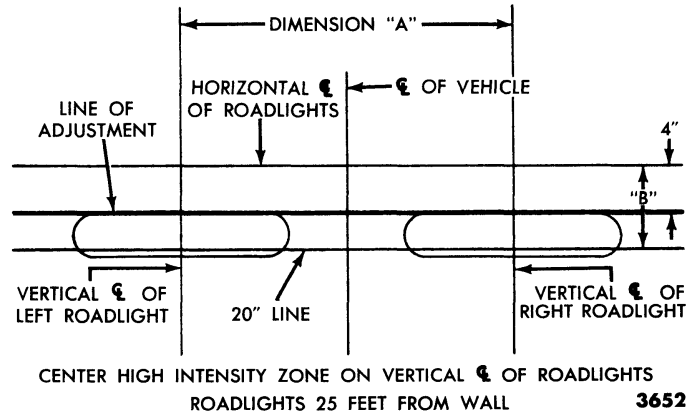

Fig. 6—Roadlight Wall Screen

upper edge of the high intensity zone touches the "Line of Adjustment" (fig. 6).

b. Bulb Replacement.

Replacement of bulbs in the lighting system is illustrated in figs. 8 through 13. These illustrations cover headlights, roadlights, spotlights, parking lights, tail, stop, and license plate lights, domelights, and instrument lights.

(1) **HEADLIGHTS.** Remove the retaining screw and headlight trim ring (fig. 7). Loosen the retaining ring screws, rotate the retaining ring counterclockwise, and remove it. The headlight bulb may now be pulled forward far enough to disconnect the wiring assembly plug.

Plug in the new bulb, and place it in position, making sure that the locating tabs are placed in the positioning slots. Install the retaining ring, rotating it clockwise under the screws, and tighten the screws. Hook the trim ring at the top, pull it down into position, and replace the screw.

(2) **PARKING LIGHT.** To replace the bulb in the parking light remove the retaining screws, lens, and

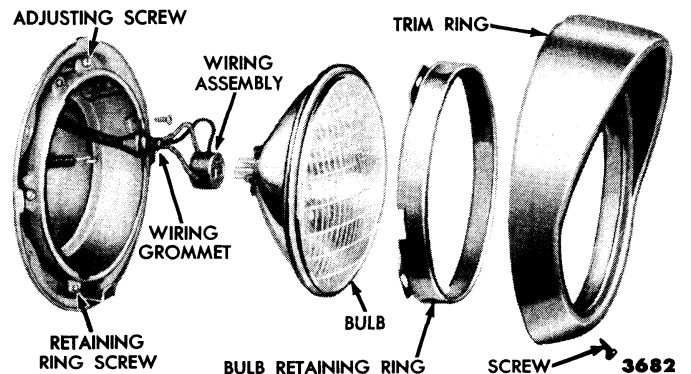

Fig. 7—Headlight—Disassembled

3682

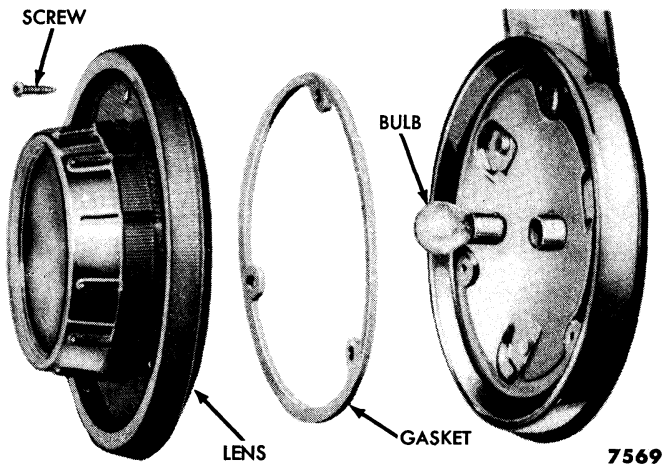

Fig. 8—Tail and Stoplight—Disassembled

gasket. The bulb is the double contact bayonet type for use with the turn indicator. After the bulb is replaced, the gasket, lens and retaining ring are then replaced.

(3) **TAIL AND STOP LIGHT, AND LICENSE PLATE LIGHTS.** The tail and stop light is shown disassembled in fig. 8. To replace the bulb, remove the retaining screws, lens, and gasket.

The license plate light (except Thunderbird) is shown in fig. 9. Remove the socket retaining screws, lens, and gasket. The bulb may then be removed.

A disassembled view of the Thunderbird license plate light is shown in fig. 10. For access to the two light bulbs remove the retaining ring screws, retaining ring, lens and gasket. To remove the socket assembly for replacement, disconnect the wire from the bullet connector which may be reached through the access hole to the right of the gas tank cover door, and remove the two mounting screws and the assembly.

(4) **INTERIOR LIGHTS.** The dome light is a die-cast unit. Access may be had for bulb replacement by removing the plastic lens. Squeeze the lens, across the narrow dimension, to disengage the locking tabs, then

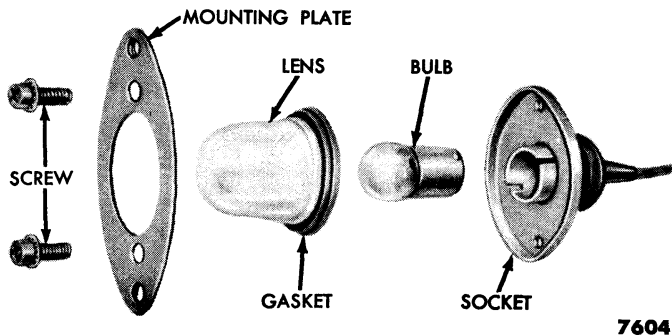

Fig. 9—License Plate Light—Disassembled

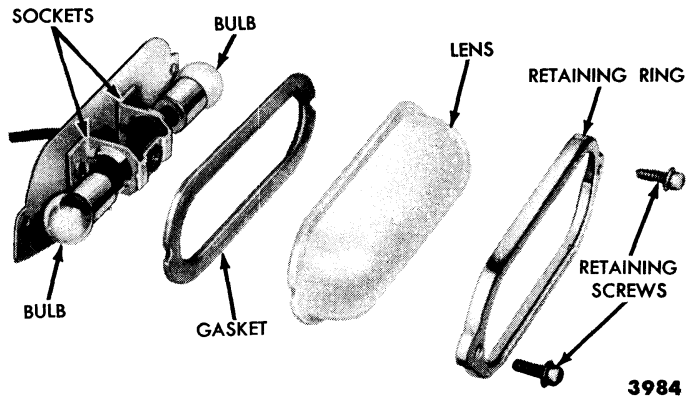

Fig. 10—Thunderbird License Plate Light—Disassembled

remove the lens from the housing (fig. 11).

(5) **INSTRUMENT LIGHTS.** The instrument panel light bulbs can be replaced by pulling out the individual light sockets from the rear of the panel (fig. 12).

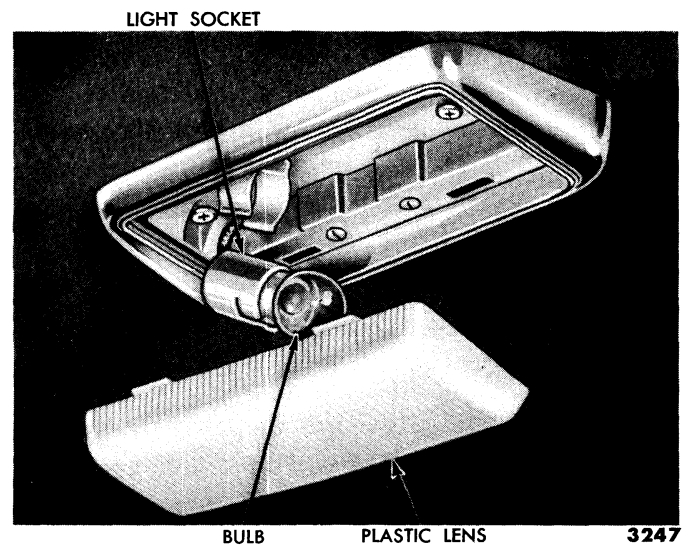

Fig. 11—Dome Light—Disassembled

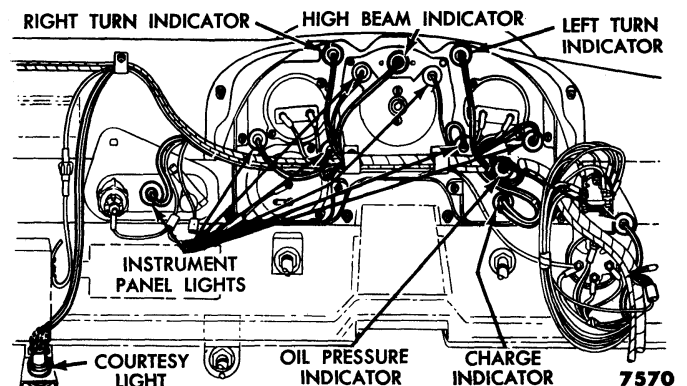

Fig. 12—Instrument Panel Lights

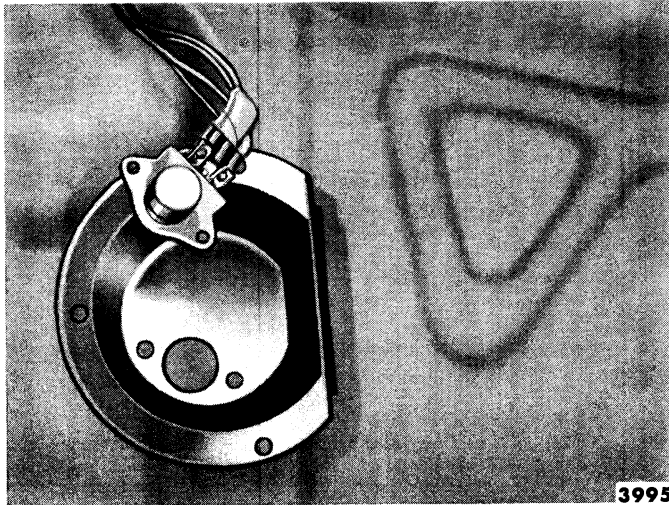

Fig. 13—Headlight Beam Control Switch

c. Switches.

Illustrated procedures for the replacement of the headlight switch, beam-control switch, stop light switch, dome light switch and ignition switch are given here.

CAUTION: Before removing any switch, disconnect a battery cable from one of the battery terminals.

(1) **HEADLIGHT SWITCH.** Remove the control knob and shaft by pressing the spring-release button on the switch housing with knob in the OFF position. Turn the shaft slightly, and pull it out of the switch.

Unscrew the mounting nut, remove the bezel and switch, and disconnect the wires.

To install the switch, connect the wires to their terminals, insert the switch in the instrument panel, and install the bezel and mounting nut. Install the knob and

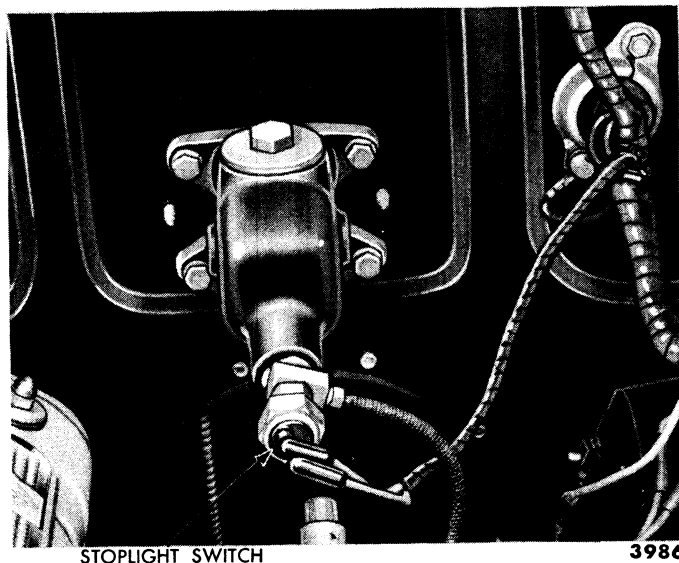

Fig. 14—Stop Light Switch—Conventional Models

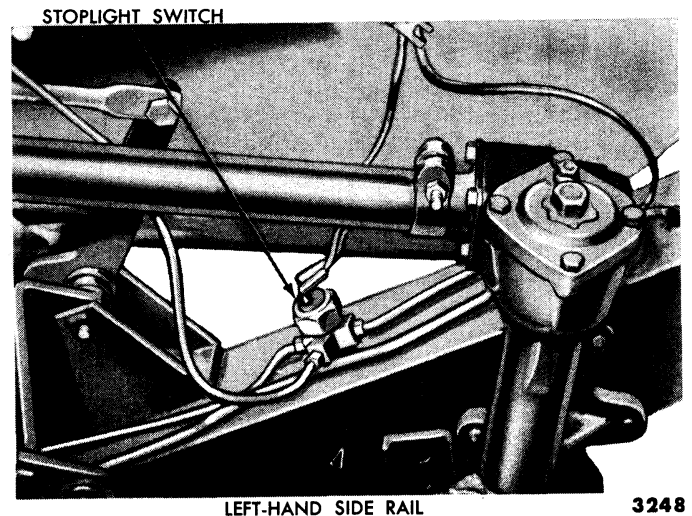

Fig. 15—Stop Light Switch—Thunderbird

shaft assembly by inserting it all the way into the switch until a distinct click is heard. In some instances it may be necessary to rotate the shaft slightly until it engages the switch-contact carrier.

(2) **HEADLIGHT BEAM CONTROL SWITCH.** Lay the floor mat back from the area of the switch, and remove the mounting plate screws (fig. 13). Remove the switch from the mounting plate, and disconnect the three wires at the switch.

To install the switch connect the wires to the switch terminals, mount the switch on the mounting plate, and install the plate and switch to the floor. Replace the floor mat.

(3) **STOP LIGHT SWITCH.** Disconnect the wires at the bullet connectors, and unscrew the switch from the master-cylinder (figs. 14 and 15).

After installing the stop light switch, bleed the brakes.

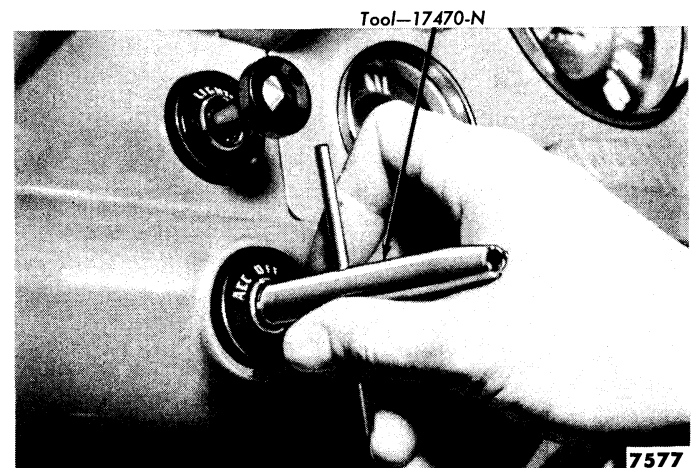

Fig. 16—Ignition Switch Removal

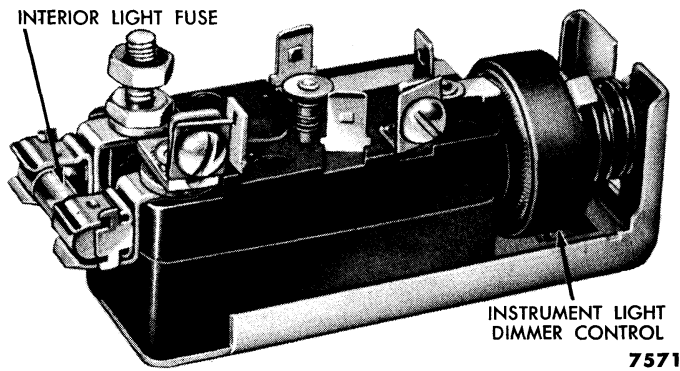

Fig. 17—Headlight Switch and Circuit Breaker Assembly

(4) **DOME LIGHT SWITCH.** The dome light switch is part of the dome light assembly. It is accessible after the plastic lens, and the socket and housing assembly, are removed.

(5) **IGNITION SWITCH.** The ignition switch is removed and installed at the rear of the instrument panel. Press in the switch body from the rear of the panel. Rotate the bezel ¼ turn counterclockwise (fig. 16), then remove the switch from the rear of the panel, and disconnect the wires from the switch terminals.

d. Circuit Breaker and Fuses.

A combination headlight switch, circuit breaker and fuse assembly is used (fig. 17). One of the circuit breakers protects the headlight circuit, the second circuit breaker protects the instrument lights, parking

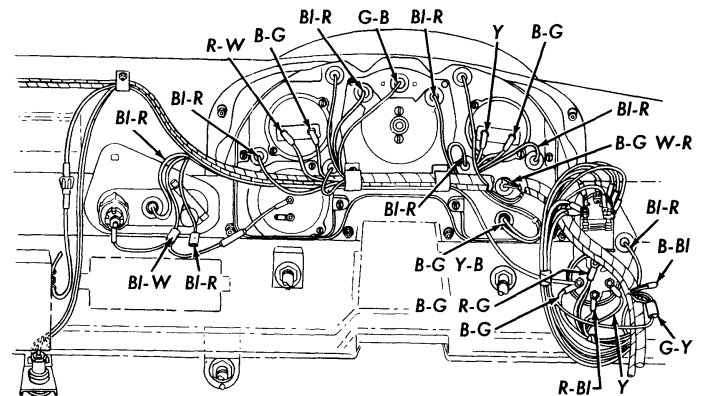

R-W	Red—White Band	W-R	White—Red Band
B-G	Black—Green Band	R-G	Red—Green Band
BI-R	Blue—Red Band	B-BI	Black—Blue Band
G-B	Green—Black Band	G-Y	Green—Yellow Band
Y	Yellow	BI-W	Blue—White Band
Y-B	Yellow—Black Band	R-BI	Red—Blue Band

Fig. 18—Instrument Panel Wiring

lights and the stop light and tail light circuits. The fuse protects the interior lighting circuit.

The action of the breaker is thermostatic in nature. If the current becomes excessive, the bi-metallic breaker arm heats, pulls away from the contact point, and breaks the circuit. When the breaker cools, contact is again made, and the circuit is restored. The breaking action is positive with no “fluttering” of the contacts.

Breaker assemblies are integral with the headlight switch and are serviced as an assembly. The unit is mounted as shown in fig. 18. The 7½ ampere fuse is mounted on the back of the assembly.

3. HORNS

Passenger cars are equipped with a pair of tuned horns controlled by means of a relay. The horn button closes the relay contacts, completing the circuit to the horns. One of the horns has a high-pitched tone; the other has a low-pitched tone. Figure 19 shows the wiring connections to the horn relay.

a. Test and Adjustment.

The only test that can be made on the horns is for current draw. The tone adjustment also adjusts the current draw.

(1) **CURRENT DRAW TEST.** Connect a voltmeter and ammeter to the horn and a voltage supply as shown in fig. 20. The normal current draw for the horns at 12-12.6 volts is 9.2-9.6 amperes.

(2) **ADJUSTMENT.** Tone is adjusted by changing the contact tension (fig. 21). Connect the horn as shown in fig. 20. Back off the lock nut, and turn the tone-adjusting nut until the current is within the limits for the horn being adjusted. Tighten the lock nut, and recheck the current draw.

b. Replacement.

The horns are mounted on the radiator support (fig.

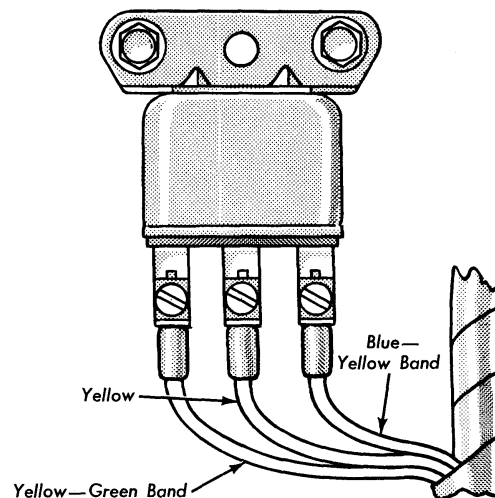

Fig. 19—Horn Relay Wiring Connections

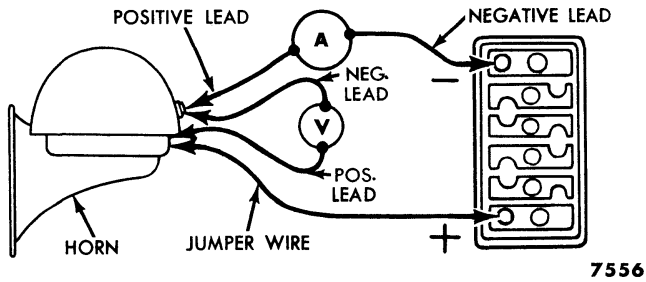

Fig. 20—Horn Current Draw Test

22). On cars equipped with 8-cylinder engines, remove the fender apron support bar. Disconnect the horn wires at the terminals, remove the mounting bolts and remove the horns.

On cars equipped with 6-cylinder engines, remove one of the parking light housings before removing the horns.

NOTE: *On the Thunderbird, the horns are mounted on the radiator side air deflector. They may be removed through an access hole, at the center of the radiator lower air deflector.*

To install, place the horn in position, and install the mounting bolts. Install the horn wire.

c. Horn Ring Removal.

The horn ring assembly (fig. 23) can be removed by pressing down evenly on the ring and turning it counter-

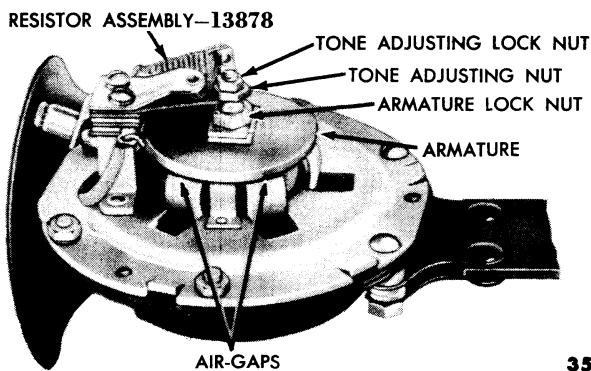

Fig. 21—Horn Adjustment

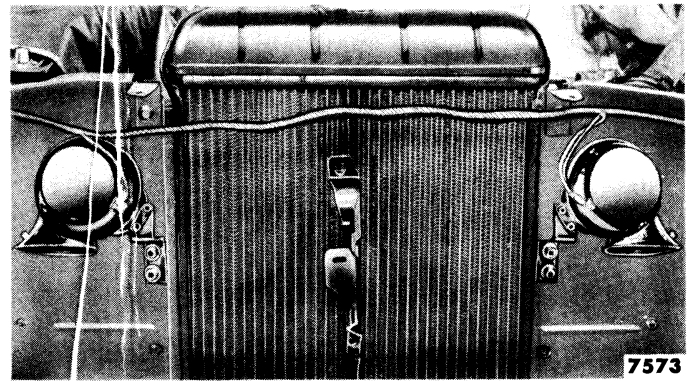

Fig. 22—Horn Installation

clockwise until it lifts out. It is advisable to disconnect the bullet connector at the lower end of the steering column to prevent the horn from sounding during this operation.

NOTE: *On the Thunderbird, the horn ring is removed by first removing two screws at the back of the steering wheel.*

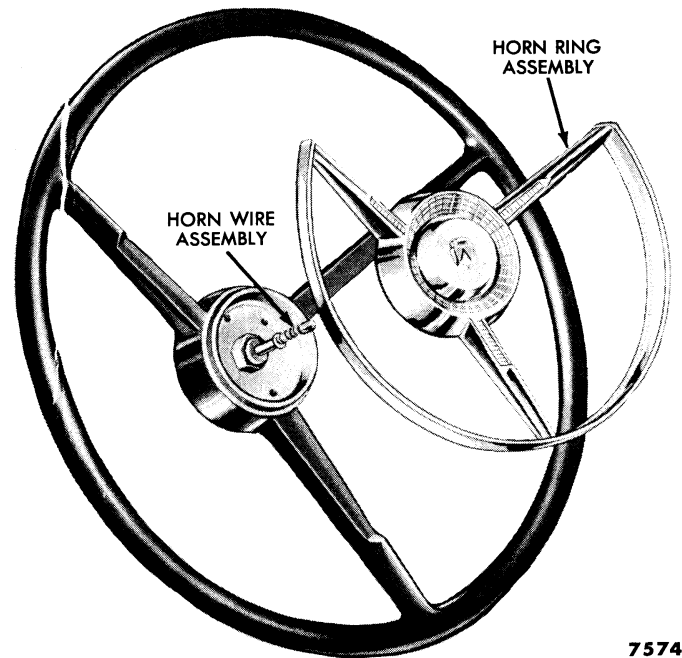

Fig. 23—Horn Ring—Disassembled

4. INSTRUMENTS

The instrument cluster includes a charge indicator light, fuel gauge, oil pressure indicator light, temperature gauge, speedometer and provision for an electric clock. All of the instruments are electrically operated except the speedometer. Illumination is provided by six lights controlled by a rheostat on the lighting switch.

This section contains information on operating principles and tests of the various units in the instrument

cluster assembly. A circuit diagram showing the connections of the gauges and lights is shown in fig. 24.

To remove the instrument cluster assembly, remove the steering column bracket cover, disconnect the instrument wires, remove the light sockets, the speedometer cable, and the eight mounting nuts. Lift the cluster out at the front of the instrument panel. Fig. 18 shows the wiring connections to the various instruments.

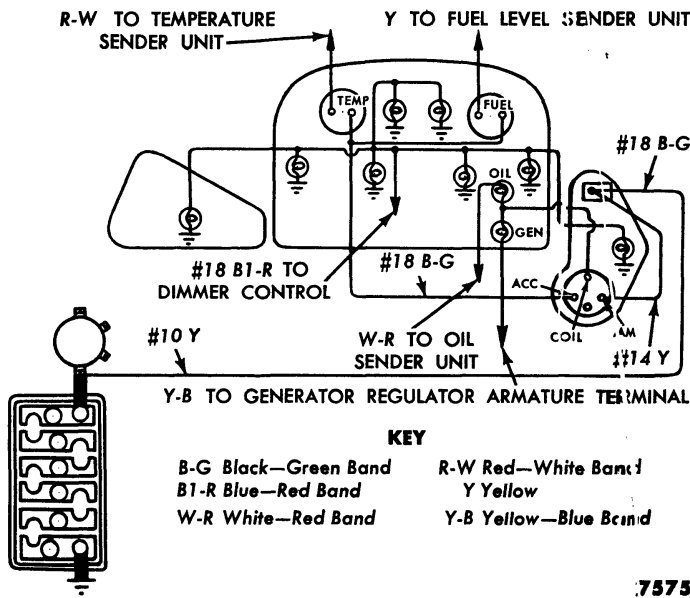

Fig. 24—Instrument Cluster Circuit

Individual instruments can be removed without removing the assembly. Disconnect the instrument wires, remove the mounting screws which retain the instrument in the cluster assembly, and remove the instrument.

a. Charge Indicator Light.

A red, generator charge indicator light is used on all models. This light flashes on if the battery is discharging and the generator is not supplying current. The indicator light is connected between the armature terminal of the generator regulator and the coil terminal of the ignition switch. This actually places the light across the regulator cut-out contacts. If the ignition switch is on, and the cut-out contacts are open, the charge indicator light will light up, indicating that the generator is not connected to the battery. The circuit for the light is from the battery, through the light, and through the generator armature, to ground (fig. 25). As soon as the generator comes up to speed, the cut-out contacts close. This by-passes the warning light which then goes out and thus indicates that the battery is connected to the

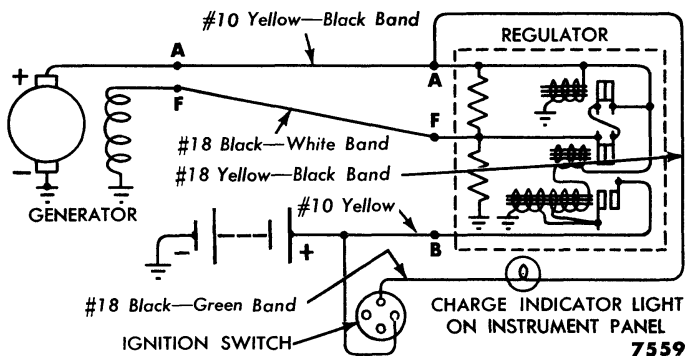

Fig. 25—Generator Charge Indicator Light Circuit

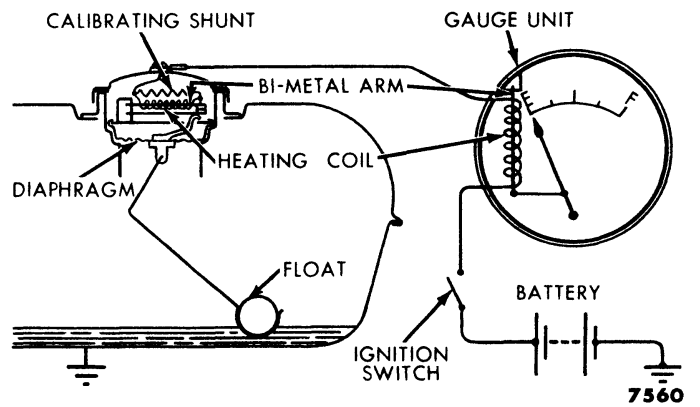

Fig. 26—Fuel Gauge Circuit

generator.

To test the charge indicator light, turn the ignition switch on with the engine stopped. The light should come on. If it does not, the light is either burned out or the wiring to the light is defective.

b. Fuel Gauge.

The fuel gauge consists of a sending unit, located on the gas tank, and a remote register unit (fuel gauge) mounted in the instrument cluster. The sending unit uses a bi-metallic element and heating coil to control the average current flowing through the gauge circuit. The position of the gauge pointer is controlled by another bimetallic element and heating coil. The fuel gauge circuit is shown in fig. 26.

(1) **OPERATING PRINCIPLES.** When the fuel tank is empty, the contacts in the tank unit are just touching (see fig. 26). With the ignition switch ON, current flows through the circuit and warms the tank unit bimetallic element by means of the heating coil, causing the element to bend and the contacts to open. The current is interrupted, allowing the element to cool and close the contacts. The cycle then repeats. The current to the heating coil in the tank unit must also flow through the heating coil in the gauge unit. Consequently, the amount of heat supplied to the gauge unit is the same as that in the tank unit. This heat is controlled by the average current flowing through the circuit due to the repeated opening and closing of the contacts in the tank unit. With the tank empty, the gauge bimetallic element therefore assumes the same relative position as the tank unit element, and the pointer is at the "E" position on the gauge.

When the tank is filled, the float rises with the fuel level in the tank and the cam moves the grounded contact toward the bimetallic arm, increasing the tension holding the contacts closed. A greater amount of current is required to heat the tank unit bimetallic arm enough to cause it to open the contacts. A similar greater

bending of the bimetallic arm in the gauge unit results in a movement of the needle toward the "F" (full position point) of the scale.

Because the bimetallic element changes temperature rather slowly, the effects of sudden changes in fuel level are reduced, and a steady reading of the average level in the tank is indicated by the gauge.

(2) **FUEL GAUGE SYSTEM TEST.** The method presented for testing the fuel gauge unit can also be used to check the temperature gauge unit. The gauge unit test will determine the accuracy of the gauge unit.

(a) **GAUGE UNIT TEST.** Place the ignition switch in the off position, and connect the terminals of two, series connected, flashlight cells to the gauge terminals. The 3 volts should cause the gauge to read approximately $\frac{1}{2}$ scale (pointer vertical). Two cells of a storage battery may also be used for this test. If 4 volts from a storage battery are used, the gauge should read approximately $\frac{3}{4}$ scale.

(b) **SENDING UNIT TEST.** The sending unit can be tested by first making a gauge unit test to determine the accuracy of the instrument panel gauge unit. If the gauge unit is inaccurate or does not indicate, replace it with a good unit. If the gauge unit still indicates improperly or is erratic in its operation, the sending unit or wiring to the sending unit is faulty.

c. Oil Pressure Indicator Light.

All models are equipped with a red indicator light which flashes on when the oil pressure is below a safe value. The light should come on when the ignition switch is first turned on, and it should go out when the engine comes up to speed. The light is connected between the oil pressure switch unit and the gauge terminal of the ignition switch.

(1) **OPERATING PRINCIPLES.** The oil pressure indicator light consists of the indicator light in the instrument panel and an oil pressure operated switch which is connected to the oil system.

When the engine is not operating, the oil pressure operated switch is closed. Thus, with no oil pressure, current flows from the gauge terminal of the ignition switch through the oil pressure switch, and the light is illuminated.

As the engine comes up to speed, the oil pressure increases, and after the pressure has risen to a safe value, the oil pressure operated switch opens up, allowing the light to go out. As long as the oil pressure is maintained, the indicator light will remain out. If at any time the oil pressure in the system drops below about seven pounds, the switch closes and the light comes on.

(2) **INDICATOR LIGHT TEST.** To test the indi-

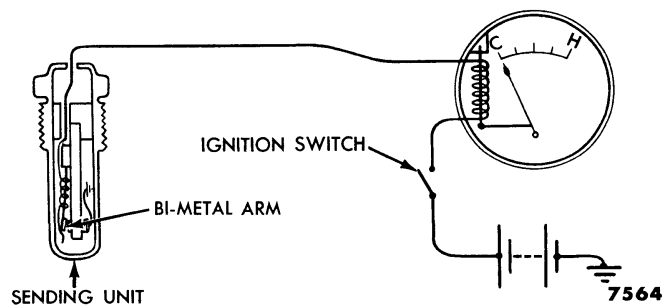

Fig. 27—Temperature Gauge Circuit

cator light, turn on the ignition switch. Do not start the engine. The light should come on. Start the engine. The light should go out, indicating that the oil pressure has built up to a safe value.

(3) **OIL PRESSURE SWITCH REPLACEMENT.** The oil pressure switch used with the indicator light unit is mounted to the rear of the oil filter on 8-cylinder engines and on the right side of the engine just above the starter on 6-cylinder engines.

d. Temperature Gauge.

The temperature gauge consists of a sending unit, mounted in the cylinder head, and a remote register unit (temperature gauge) mounted on the instrument panel. The principle of operation is similar to the fuel gauge except that the tension on the sending-unit bimetallic strip is varied by engine temperature. The temperature gauge circuit is shown in fig. 27.

(1) **OPERATING PRINCIPLES.** When the engine is cold, the bimetallic arm in the sending unit has maximum tension holding the contacts closed. Maximum average current is necessary to cause the contacts to open. The heating effect of the current causes the gauge unit bimetallic arm and pointer to deflect toward the "C" position of the scale. As the engine temperature increases, less current is required to keep the contacts at the break point since the increase in engine temperature causes the sending-unit bimetallic arm to bend away from the grounded contact. The gauge-unit pointer then registers toward the "H" position on the scale.

The center mark on the gauge face is considered "Normal" operating temperature, and the "H" mark is the boiling temperature.

(2) **GAUGE UNIT TEST.** Perform the same test as that described for the fuel gauge. The temperature gauge pointer should read approximately $\frac{1}{2}$ scale (pointer vertical), ($\frac{1}{4}$ scale if 4 volts are used). This test will determine the accuracy of the instrument panel gauge unit.

(3) **SENDING UNIT TEST.** The sending unit can be

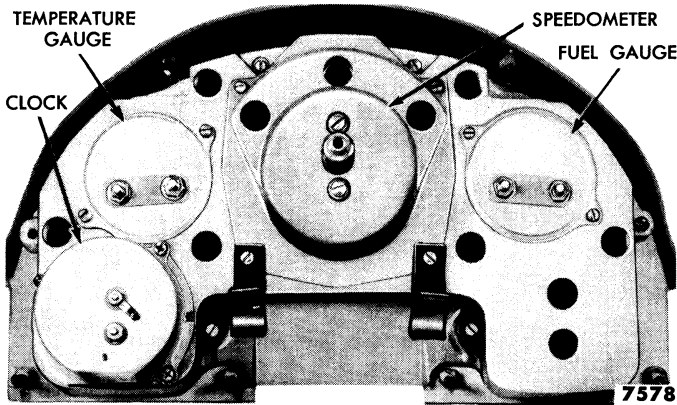

Fig. 28—Instrument Cluster—Rear View

tested by first making a gauge unit test to check the accuracy of the gauge unit. Start the engine and allow it to warm up to normal temperature. If no reading is indicated on the gauge, check the sending unit to gauge wire by removing the wire from the sending unit and momentarily grounding the wire. If the gauge still does not indicate, the wire is defective. Repair or replace the wire. If the gauge now indicates, the sending unit is faulty.

(4) **SENDING UNIT REPLACEMENT.** The sending unit can be removed by disconnecting the wire at the unit terminal and unscrewing the unit from the cylinder head.

e. Speedometer.

The speedometer is connected to the output shaft of the transmission by means of a flexible shaft, and a drive gear located inside the transmission. The flexible shaft drives the speedometer which registers speed in miles per hour and also drives an odometer which records distance traveled in miles and tenths of a mile.

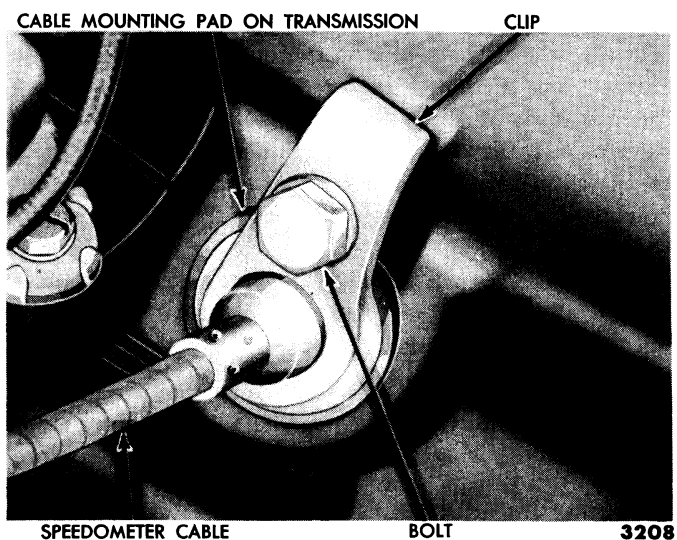

Fig. 29—Speedometer Cable Housing—Transmission Mounting

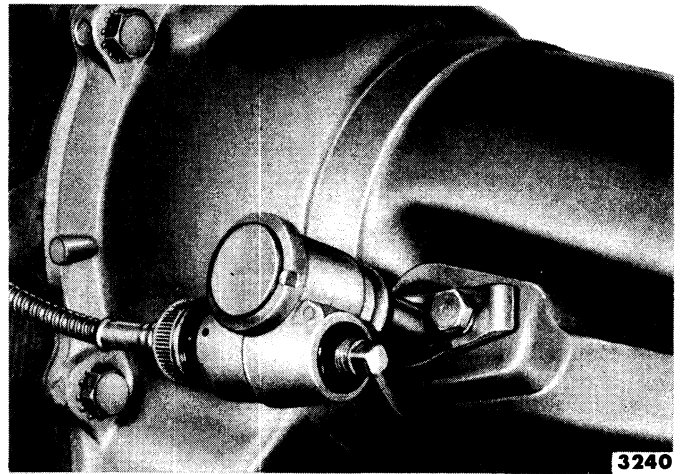

Fig. 30—Speedometer Cable Housing—Thunderbird Transmission Mounting

(1) **SPEEDOMETER TESTS.** To test the odometer accuracy, drive the vehicle over a "measured mile." Speedometer accuracy can be checked by comparing the speedometer in question against one known to be accurate, while two vehicles are moving at the same speed, or by timing the vehicle on a "measured mile."

Most cases of speedometer inaccuracy are due to a change to non-standard tire sizes without changing the speedometer drive gear ratio. Refer to the car Chassis Parts Catalogue for the proper gears to use for various rear axle-tire size combinations.

(2) **REMOVAL AND REPLACEMENT.** The speedometer unit may be removed from the instrument cluster without removing the cluster. Disconnect the speedometer cable from the unit and remove the four speedometer mounting screws. Rotate the unit about a quarter turn clockwise and remove it from the cluster. Replace the speedometer by reversing the removal procedure. Figure 28 shows a rear view of the instrument cluster.

(3) **SPEEDOMETER CABLE REPLACEMENT.** The speedometer cable is coupled to the speedometer at the speedometer end of the cable, through a short rubber shaft, to reduce noise transmission. To replace the speedometer drive cable, disconnect the cable housing at the speedometer, and pull the cable out of the housing. Insert a new cable all the way into the housing, and twist it slightly to make sure that the squared drive is engaged in the transmission drive bushing.

NOTE: If a speedometer cable is broken, it will be necessary to disconnect both ends of the cable housing in order to remove the broken sections.

The housing is fastened to the transmission as shown in fig. 29. On the Thunderbird a special right angle drive couples the speedometer cable to the transmission housing (fig. 30).

Part THREE

ELECTRICAL AND ACCESSORIES

Chapter IV

Accessories

Section	Page
1 Trouble Shooting	257
2 Radio	260
3 Heater	265
4 Windshield Wiper	268
5 Miscellaneous Accessories	269

1. TROUBLE SHOOTING

a. Radio.

Procedures for the location and elimination of the majority of minor troubles interfering with normal radio receiver operation, are presented here. The procedures given are not intended to cover all of the possible radio receiver troubles. Each procedure either locates the minor trouble or determines that the receiver should have a major repair. As a major repair on the radio should only be made by a competent radio repairman, do not go beyond the procedures given.

The following parts will be required to make the radio trouble shooting tests:

- Spare Fuses (5 and 7.5 ampere)
- Antenna and lead
- Speaker
- Two 12-volt Vibrators, 3 prong Bendix, 4 prong Motorola
- Radio Tubes (One each: 12AB5, 12AQ5, 12AU6, 12AU7, 12AV6, 12BA6, 12BE6, 12X4)
- Suppression Condensers (Complete Set)
- Distributor High Tension Lead.

NOTE: Pretest and mark all of the test parts (except fuses) so that these known good parts will not be left in a tested receiver.

(1) **NO RECEPTION.** Turn the ignition switch to the accessory position and turn the receiver on. Listen for the vibrator to buzz. If the vibrator is not buzzing follow "(a) No Vibrator Buzz" below. If the vibrator is buzzing follow "(b) Vibrator Buzzes" below.

(a) **NO VIBRATOR BUZZ.** Check to see if the fuse is blown. If the fuse is blown follow "(1) Fuse Is Blown"

below. If the fuse is not blown follow "(2) Fuse Is Not Blown" below.

(1) **FUSE IS BLOWN.** If the fuse is blown, remove the vibrator, install a new fuse and check to see if the tubes are lighted. Ignore the pilot light as it is fed by a separate lead.

If the tubes do not light up, make certain that voltage is available at the "A" lead and if it is, remove the receiver for major repair.

If the tubes light up, plug in the original vibrator. If the new fuse blows replace the fuse and plug-in the test vibrator. If the set plays, replace the test vibrator with a new vibrator. If however this fuse blows, replace the 12X4 rectifier tube (fig. 6), and the fuse. If the fuse blows again, remove the receiver for major repair.

(2) **FUSE IS NOT BLOWN.** Check for voltage at the "A" lead with a voltmeter. If 12 volts are available and the tubes are lighted, plug in the test vibrator. If there is no reception or if the tubes do not light up, remove the receiver for major repair.

(b) **VIBRATOR BUZZES.** If the vibrator buzzes when the set is turned on, connect the test antenna to the receiver and hold it so that it protrudes out of the vehicle. If this cures the trouble install a new antenna and lead.

If the antenna is not at fault, disconnect the speaker and plug in the test speaker. If this cures the trouble replace the old speaker.

If the speaker is not at fault, substitute the test tubes for those in the receiver, one at a time, allowing enough time for each tube to heat up before going on to the next. Start the substitution with the 12X4 rectifier tube (fig. 6), as it is more likely to be defective than the

others. If the receiver still will not play, it must be removed for major repair.

NOTE: *After performing all of the preceding checks, be sure to remove all tubes, vibrator etc., marked and used for testing.*

(2) **NOISY OR ERRATIC RECEPTION.** The cause of noisy or erratic reception can be isolated by finding out when the noise occurs. If it occurs while the vehicle is at a standstill with the engine not running, the trouble lies in the radio receiver or the fuel sending unit. If the noise occurs only while the vehicle is standing with the motor running, it is probably caused by ignition or electrical units on the vehicle. If the noise occurs only while the vehicle is in motion, it is probably caused by wheel and tire static, or by intermittent shorting of the antenna.

(a) **NOISY WHILE STANDING—ENGINE NOT RUNNING.** Tune in a local station, and jar the side of the receiver case with the hand.

Make sure that the connector plugs are firmly seated. If the connectors are secure and the noisy reception continues as the receiver is jarred, tap the tubes gently with the finger tips, while holding the tubes in the socket to eliminate disturbing the tube contacts. If the receiver becomes noisy as any particular tube is tapped, replace the defective tube. If none of the tubes are noisy, the receiver must be removed for major repair.

(b) **NOISY RECEPTION—ENGINE RUNNING.** Inspect the installation of suppression equipment (fig. 8). If the suppression equipment is complete, substitute the good test parts one at a time. Be sure that all condensers are properly grounded.

Check the routing of the receiver "A" lead. The "A" lead should be in the wiring harness clips behind the instrument cluster and above the cigar lighter. Check the receiver mounting to determine if the paint and deadener were properly removed before the receiver was mounted. The receiver must make a good ground contact both at the support bracket mounting and where the receiver contacts the instrument panel.

(c) **NOISY RECEPTION—VEHICLE IN MOTION.** Retract the antenna and flex it slightly to let it vibrate. Move and twist the lead-in slightly. If noise occurs when this is done, replace the antenna.

(3) **DISTORTED OR GARBLED SOUND.** Distorted or garbled sound may be caused by the voice coil rubbing on the center pole piece of the speaker magnet, by a torn speaker cone, by foreign material coming in contact with the cone, or by a defective tube in the receiver. The voice coil may be thrown out of alignment by a twisting or bending of the speaker frame if the speaker unit is improperly mounted in the speaker grille. To determine if the speaker is at fault, substitute the test speaker before removing the suspected unit.

When installing a new speaker, tighten the attaching nuts finger tight only.

If the reception is not improved, substitute tubes as described in paragraph "(b) Vibrator Buzzes" above, but start with the output tubes (fig. 6).

(4) **WEAK RECEPTION.** When reception is limited to a few strong local stations, adjust the antenna trimmer to align the receiver to the antenna. Substitute the test tubes as described in paragraph "(b) Vibrator Buzzes" above.

(5) **SEARCH TUNER RUNS CONTINUOUSLY.** When checking the operation of the search tuner, make certain first that the manual portion of the receiver will tune-in distant stations, that the antenna is fully extended, and that the antenna trimmer is adjusted.

It may also be necessary to move the vehicle to a location where normal station signal strength is available (out of and away from steel reinforced buildings).

If the search tuner runs continuously when the "T" or "C" button is operated, to stop the tuner from running, turn the receiver off, then turn it back on.

If the search tuner starts and runs continuously after the receiver has been turned on and the "T" and "C" buttons have not been operated, remove the receiver for major repair.

In country areas where there are no local stations, operate the "C" button only, to test the search tuner. If the tuner still runs continuously when the "C" button is operated and the above conditions are fulfilled, the receiver must be removed for a major check-up.

b. Heater.

Two symptoms of heater trouble are given below as "(1) Insufficient or No Heat," and "(2) Insufficient or no defrosting."

(1) **INSUFFICIENT OR NO HEAT.** The automatic temperature control unit could cause insufficient heat. With the engine at operating temperature and the temperature control lever at high, feel the heater unit, it should be warm. If it is cool, the temperature control unit could be defective, not allowing the water to circulate through the heater.

If the control unit is not at fault, inspect the control cables. Make sure that the cables are correctly installed, not kinked, and that they allow full travel of both the temperature-control valve and the air-control valve.

Incorrect water flow could also cause insufficient heat. Check the water hoses to see that they are not kinked or collapsed (possibly due to the water outlet elbow pointing in the wrong direction). Check the thermostat for proper installation and operation. It may be necessary to use a higher temperature thermostat and permanent anti-freeze in cold climates. Make sure that the heater unit is not at fault (improper heater core construction, such as no water baffle in the core

tank). If this condition exists, it may be detected by touching the heater. The left side of the heater will run cold on full water rate if there is no water baffle.

If the trouble has not already been found, inspect the heater blower for a blown fuse or loose wires. Check for a poor ground, fan loose on the motor shaft, blower wheel or housing damaged (preventing rotation), foreign objects in the blower, and damaged or burned out heater switch.

Check for air leaks in the ventilating system. Look for grommets missing in the dash or a missing felt pad around the accelerator rod. Make certain that the air intake screens and the honeycomb of the heater core are not clogged with foreign material.

Test for body air leaks caused by poor or missing seals around the doors or windows or by loose fitting doors.

(2) **INSUFFICIENT OR NO DEFROSTING.** All of the preceding procedures also apply to this subject.

In addition, check the defroster control cable; it should be connected properly to allow full travel of the defroster valve. Make certain that the defroster hose is connected, the defroster dampers are tight on the control shafts, the defroster nozzles are clear and attached, and that the slot in the windshield molding is properly formed.

c. Turn Indicator.

Figure 1 shows the turn signal schematic diagram.

(1) **TURN SIGNAL LIGHTS DO NOT OPERATE.** The fuse may be blown out, the flasher may be defective, the switch and wiring may be defective, or the lights may be burned out. Figure 2 shows a "road map" for this symptom. Before any testing is done, turn the ignition switch key to the "ACC" Position.

(a) **FUSE.** Remove the fuse to see if it is burned out.

(1) **FUSE IS BURNED OUT.** If the fuse is burned out, check the current drawn by the system by connecting an ammeter between the "ACC" terminal of the ignition switch and the fuse holder terminal that connects to the flasher unit (with the fuse removed). Place the switch in both the left and right hand positions. The current draw with the flasher operating and the front, rear, and pilot light on one side operating, should oscillate between 0 and 4 amperes at 12 volts. This is caused by the flasher turning ON and OFF. If the current is greater than this in either the right or left-hand operation, check the manual switch, flasher unit, and the associated wiring for shorts. Repair or replace wiring as necessary.

(2) **FUSE IS NOT BURNED OUT.** If the fuse is not burned out, install the fuse, then test the flasher unit by removing the unit from the flasher receptacle and plugging in a new flasher assembly.

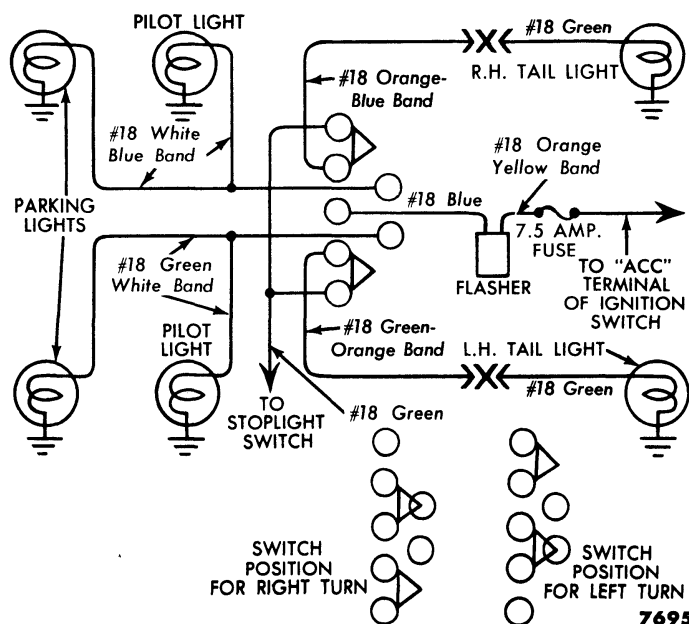

Fig. 1—Turn Signal Schematic Diagram

(a) **Flasher Assembly Defective.** If the lights now operate when the switch is operated, the flasher unit is defective, replace with the new unit.

(b) **Flasher Assembly Good.** If replacing the flasher assembly does not cure the trouble, the flasher unit may be assumed to be good. Run a jumper wire from the "ACC" terminal on the ignition switch to the center ter-

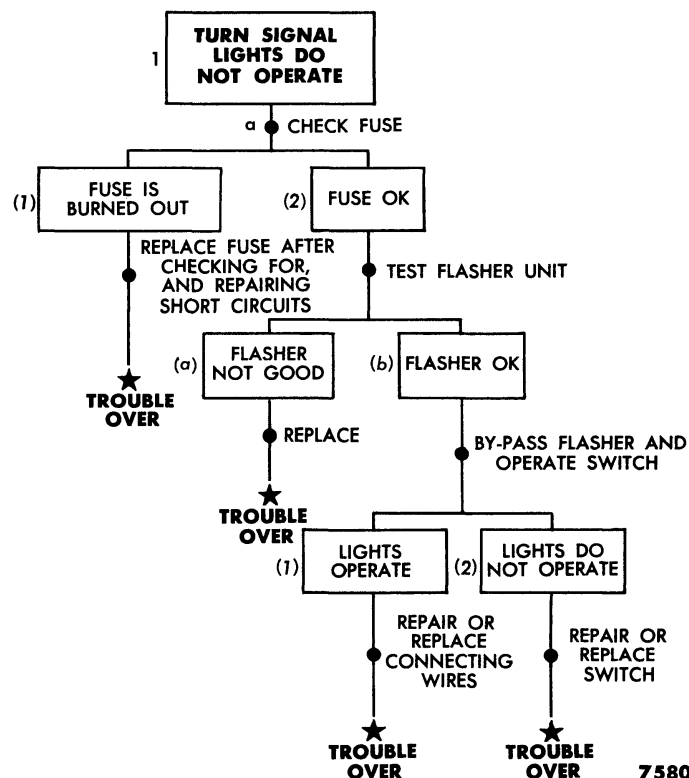

Fig. 2—Turn Signal Trouble Shooting—"Road Map"

minal (blue wire) on the manual switch. The lights should burn steadily.

(1) *Lights Burn Steadily.* If the lights burn steadily when the switch is operated, the wires running from the manual switch, through the flasher unit to the ignition switch terminal are defective or disconnected.

(2) *Lights Do Not Burn Steadily.* If the lights still do not operate, the turn indicator switch may be defective. Remove the wires from the bullet connectors that connect to the switch and temporarily connect in a new switch. If the lights now burn when the switch is operated, repair or replace the switch and wiring.

(2) **SIGNAL LIGHTS OPERATE INCORRECTLY.**

(a) **SIGNAL LIGHTS BURN BUT DO NOT FLASH.** If the signal lights burn but do not flash, check for a burned out signal light or replace the flasher assembly.

(b) **ONE SIGNAL LIGHT OUT ON EITHER SIDE.** If one signal light only is out, either the light is burned out on that side, or the wiring to the light is defective.

Check first to see if the light is burned out. The rear lights may be checked by placing the manual switch in the center position and depressing the foot brake. Both rear lights should light. If the light in question does not light while the other one does, the light is either burned out or the wiring to the light is defective.

The front lights may be tested by disconnecting the leads (green with white tracer and white with blue tracer) from the connector block behind the instrument panel, and connecting a jumper from the "ACC" terminal of the ignition switch to each lead. If the lights do not burn, the light is burned out or the wiring to the

light is defective. Repair the wiring or replace the light, whichever is indicated.

(c) **ALL LIGHTS ON ONE SIDE DO NOT BURN.** If all the lights, including the pilot light on one side only do not burn when the switch is operated, either the manual switch is defective, the wiring to all lights is defective, or all three lights are burned out. Replace the tail light on the side in question. If this light still does not burn when the turn switch is operated, the switch is probably defective. Disconnect the switch wires from the connector block behind the instrument panel, and connect a new switch in its place. If the lights now burn, the old switch is defective. Replace it. If the lights still do not burn, the wiring to all three lights is defective. Repair the wiring.

(d) **PILOT LIGHTS DO NOT BURN.** If either pilot light does not burn, the light is burned out, or the wiring to the light is defective. Replace the light or repair the wiring where necessary.

(3) **IMPROPER TURN SIGNAL CANCELLATION.** If the turn signal cancels prematurely, check the tension of the conical, switch hold down spring. Stretch the spring slightly to increase the tension.

If the turn signal does not cancel at all, measure the distance between the steering wheel hub and the steering column flange. This distance should not be more than $\frac{1}{16}$ inch for the canceling cam on the steering wheel to make positive contact with the canceling pawls on the switch. A click should be heard when the steering wheel is rotated. Make certain that there are no burrs on the steering column flange where the turn indicator shaft goes through the flange.

2. RADIO

a. General Information.

A pictorial diagram showing the radio connections is given in fig. 3.

(1) **MODEL IDENTIFICATION.** Three models of radio receivers are available. Table 1 gives information on the model identification. The model number identifies the manufacturer and is the prefix to the serial number stamped on the side of the receiver (fig. 4).

Table 1—Model Identification

Part Number	Model No.	Manufacturer	No. Tubes	Application
FDR-18805-B2	66BF	Bendix	6	All cars
FDR-18805-B1	66MF	Motorola	6	All cars
FDR-18805-E	69MF	Motorola	9	All cars
FEF-18805-B	69MS	Motorola	9	Thunderbird

The 6-tube receiver includes a rectifier tube. The 9-tube receivers include beside a rectifier tube, a tuning motor trigger tube.

(2) **CONTROLS ON THE STANDARD RADIO.** Tuning is controlled by five push buttons and by the tuning knob to the right of the receiver dial. Volume and tone are controlled by the dual knob to the left side of the receiver dial. The volume control also turns the receiver on and off.

The 9-tube receivers have a signal seeking feature but in other respects are similar to the 6-tube receiver. The signal seeking receivers have two additional tuning buttons (fig. 5). The button on the left (marked "T" for town use) operates the signal-seeking tuning motor for automatically selecting powerful urban stations. A similar button on the right (marked "C" for country use) operates the tuning motor when automatically selecting all stations that can be picked up by the receiver.

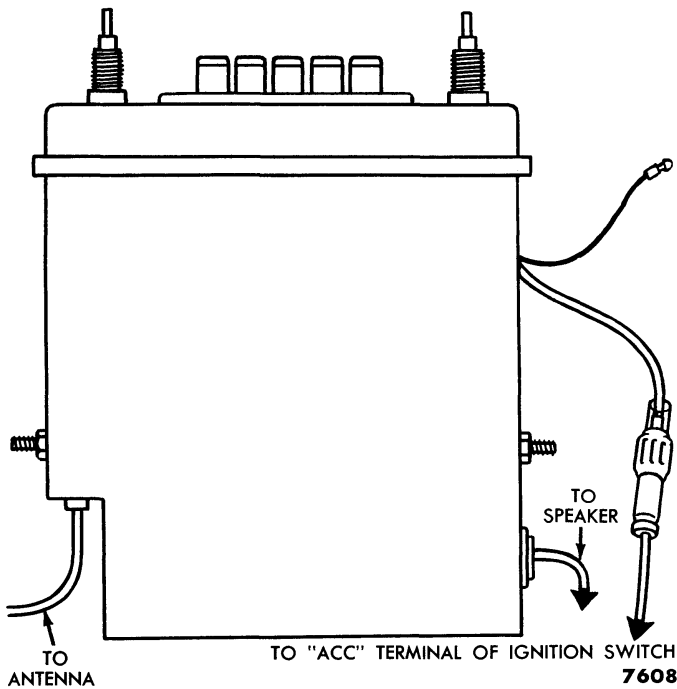

Fig. 3—Radio Wiring Connections

NOTE: The controls for the Thunderbird radio are similar to those shown in fig. 5 except that two horizontal bars above the dial are used for the "T" and "C" controls.

The signal-seeking receiver operates as follows: The tuning mechanism is controlled by a reversible motor. Touching either the "T" or "C" button puts the tuning

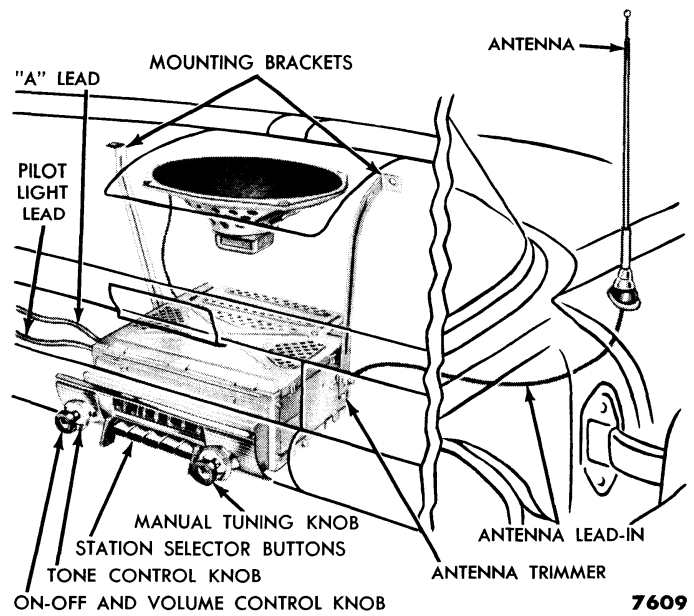

Fig. 5—Car Radio Installation

motor into operation. The "T" button will cause the dial pointer to move across the dial until it comes to the first station within "town" sensitivity range. The motor stops at the exact point where the station is accurately tuned in. The next time that the button is operated the motor will tune in the next local station, etc. The motor automatically reverses when the end of the tuning range is reached. When operating outside of urban areas, the "C" button is used and a greater selection of stations is possible.

(3) **CHASSIS CONNECTORS.** The antenna connector and trimmer condenser are located on the right side of the receiver as shown in fig. 6. The fuse is located in a plastic holder in the "A" lead which is

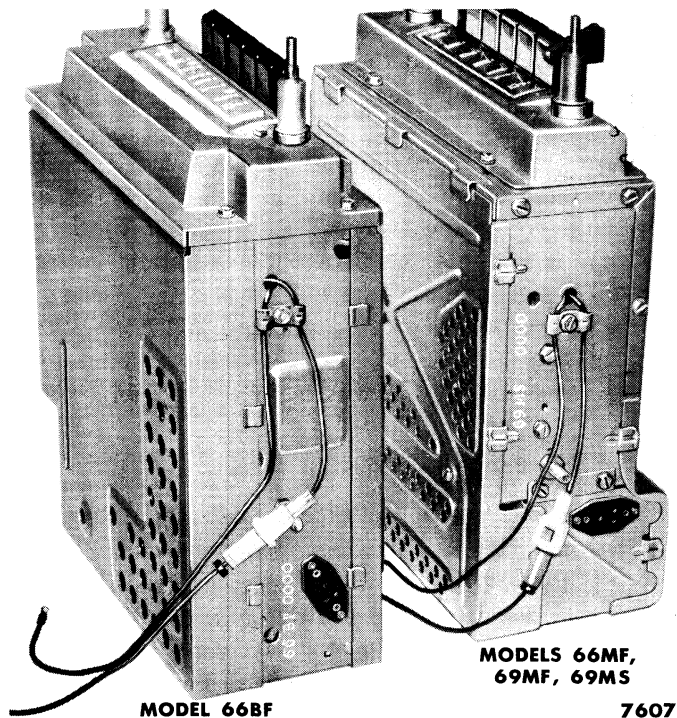

Fig. 4—Serial Number Location

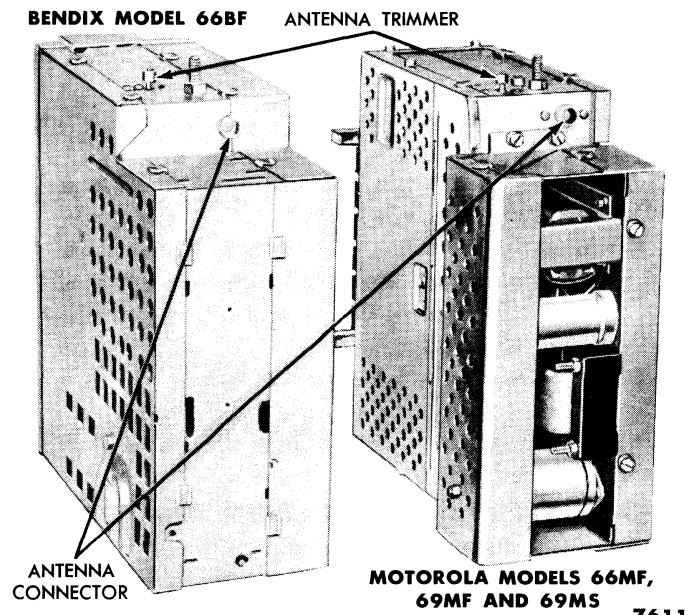

Fig. 6—Antenna Connector and Trimmer

attached to the left side of the receiver as shown in fig. 4. The speaker is connected to the receiver chassis with a three-prong polarized connector (fig. 6).

(4) **CHASSIS MOUNTINGS.** The receivers are attached to the instrument panel with two hex nuts and lock washers and by a mounting bracket on each side of the set.

The speaker unit is attached to the instrument panel by four wing nuts and is mounted directly above the chassis.

(5) **ACCESSIBILITY.** All receiver models can be tested (minor repair tests) and the tubes or vibrator changed while the receiver is mounted in the vehicle. Removal of the bottom covers permits access to all tubes and vibrator as shown in fig. 7.

(6) **REMOVAL AND INSTALLATION.** The most advantageous work position to assume while removing or installing the receiver is in the center of the front seat, directly in front of the receiver dial. Be sure that the ignition switch is off.

To remove the chassis, perform the following operations in the order stated:

(a) Disconnect the antenna lead and the speaker connector with the right hand.

(b) Disconnect the pilot light wire and "A" lead at the left of the receiver, and remove the fuse from the holder.

(c) Remove the control knobs and the panel mounting nuts.

(d) Remove the nut and lockwasher from the stud at each side of the chassis, and press the brackets away from the studs.

(e) Grasp the chassis with both hands, push it forward, and tilt it toward the towboard until the unit clears the instrument panel.

To install the chassis, perform the following steps in order:

(a) Lift the receiver into position in the instrument panel with both hands.

(b) Steady the chassis with one hand, and install the panel mounting nuts finger-tight.

(c) Slide the mounting brackets over the studs at the side of the chassis and install the nuts and lock washers. Be sure that all control cables and wiring are clear of the receiver chassis.

(d) Tighten the panel mounting nuts.

(e) Connect the speaker plug, "A" lead and fuse, push the antenna lead firmly into the connector, then connect the pilot light wire.

(7) **ANTENNA INSTALLATION.** The antenna is mounted on the right hand fender. Use the template included with the antenna to locate the mounting hole. Drill a 1½ inch diameter hole. Insert the tip of the antenna into the hole in the fender from inside the

engine compartment. Pull the antenna and cable into position and install the insulator and antenna hold down nut. Adjust the antenna during installation with a slight angle toward the rear of the car and a slight angle inward, by rotating the antenna base and insulator to match the contour of the fender. Tighten the mounting nut to 6-7 foot-pounds torque.

Detach the right hand cowl side grommet from inside of the passenger compartment. Carefully pull the antenna lead-in through the cowl opening. Punch out the hole in the cowl grommet, feed the antenna lead-in through the grommet and install the grommet into position. Route the lead-in over the top of the glove box and plug it into the antenna socket on the right side of the receiver.

(8) **SUPPRESSION EQUIPMENT.** When installing suppression items, make certain that all paint and dirt have been removed from between the condensers and the vehicle. Tighten all nuts and bolts securely.

Replace the distributor to coil high tension lead with the lead supplied in the kit. Install the lead as shown at "A" fig. 8.

It is not necessary to remove the generator assembly bolt to install the generator condenser. Loosen the bolt only enough to slide the mounting bracket under the lock washer ("B" fig. 8). Connect the condenser lead to the armature terminal of the generator.

Remove and discard the drive nail from the hood seal pad near the antenna. Cut the rear rib of the seal to accommodate the bonding clip and install the clip with the round head screw ("D" fig. 8).

Install the voltage regulator condenser as shown at "C" fig. 8. Install the condenser bracket between the body sheet metal and the regulator.

Install the fuel gauge condenser as shown at "D" fig. 8.

Remove both front hub grease caps. Clean the caps and install the static collector as shown at "E" in fig. 8. Bend the cotter key away from the spindle center hole so that it will not interfere with the static collector. Install the grease caps and hub caps.

Install the bonding cable as shown at "F" fig. 8. Use the existing holes in the engine steady rest mounting and on the rear of the cross member assembly.

b. Adjustments.

Be sure to warm up the receiver for 15 minutes before making the following adjustments:

(1) **ANTENNA TRIMMER.** Extend the antenna to its maximum length. Tune in the weakest station between 12 and 16 on the dial and reduce the volume until the station is barely audible. Turn the antenna trimmer knob, fig. 7, slowly in either direction until a peak of volume is reached.

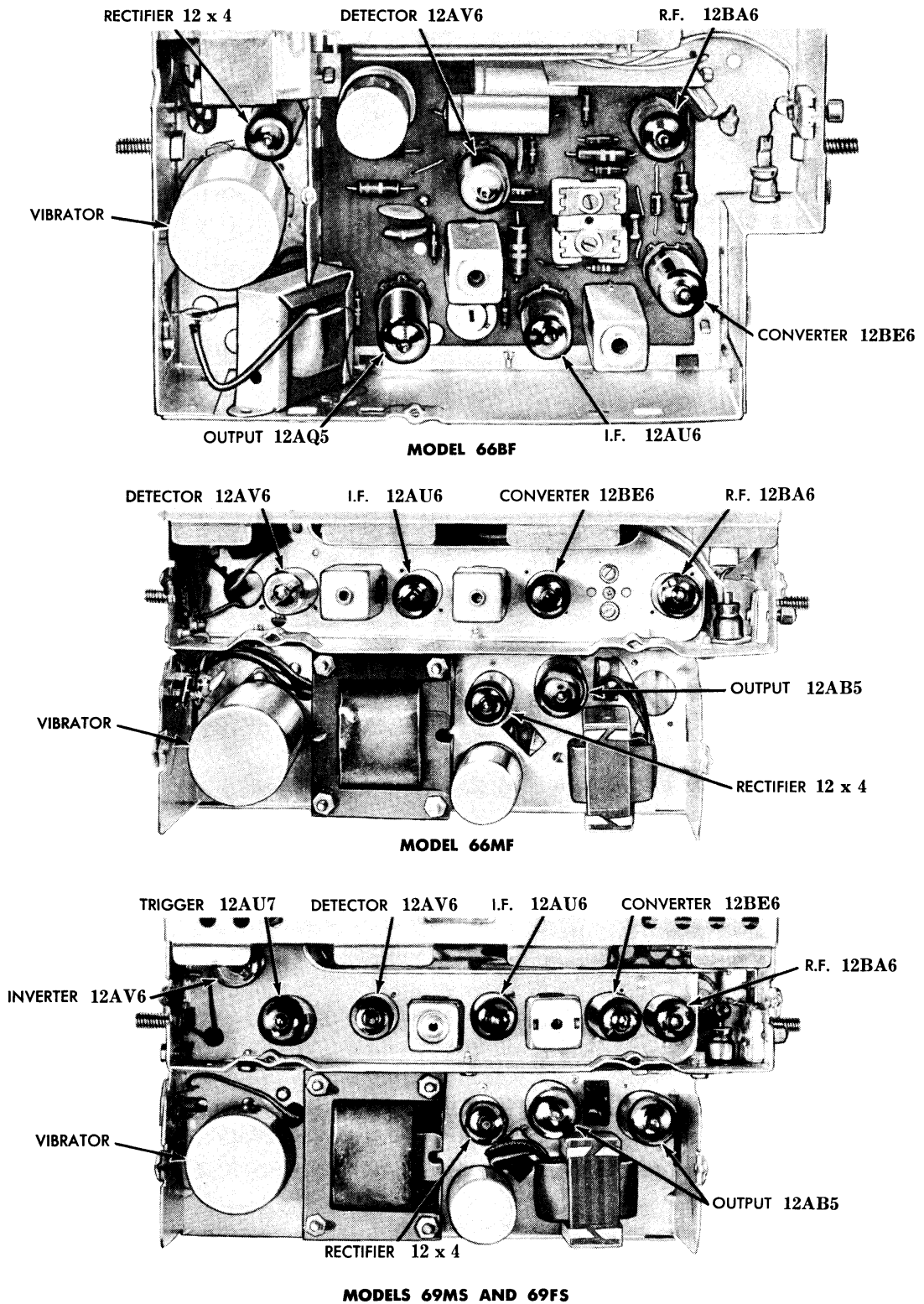

Fig. 7—Tube Arrangements

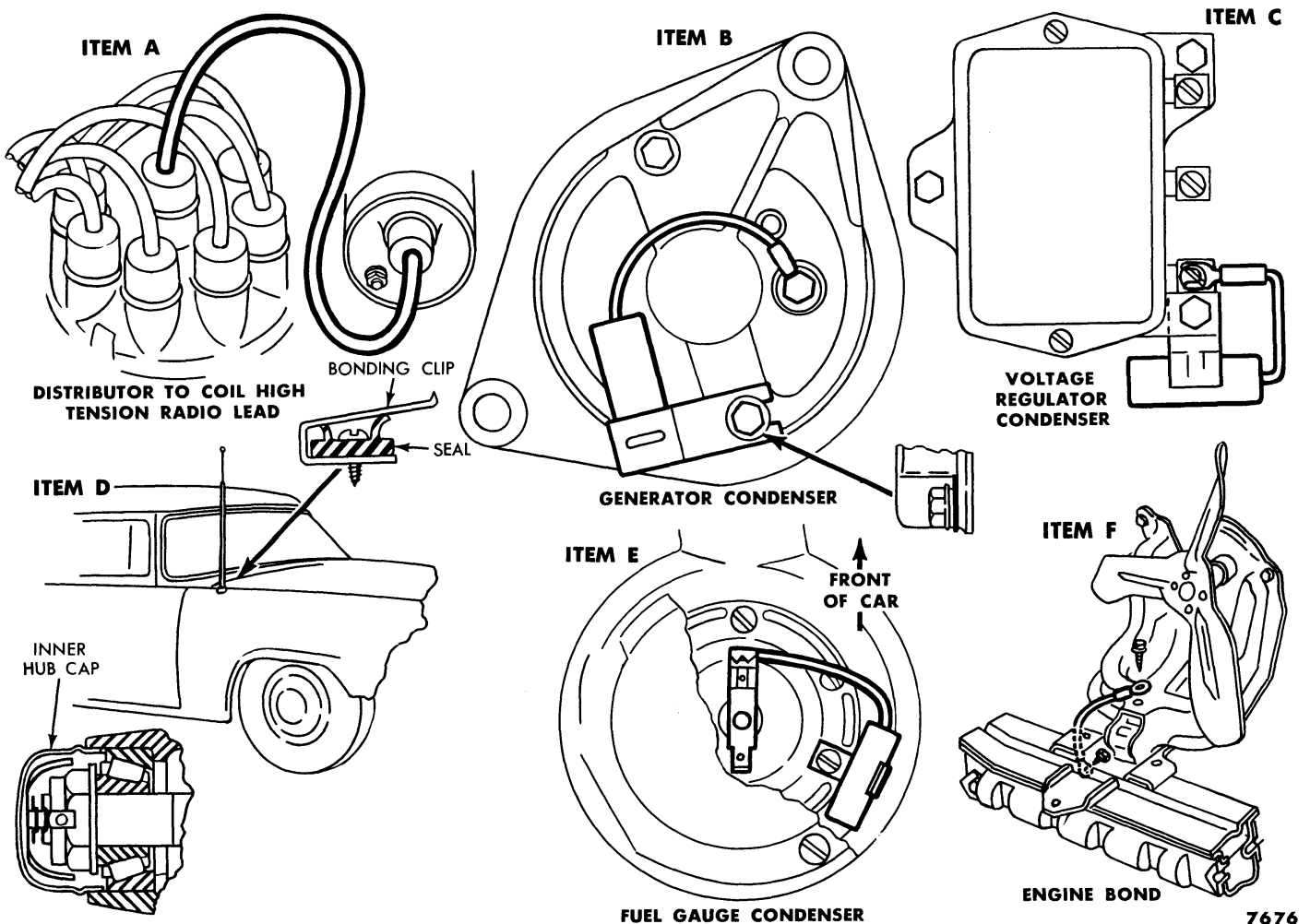

Fig. 8—Suppression Equipment Installation

(2) **PUSH BUTTON.** Adjustment of the push buttons must be made during daylight hours due to the high sensitivity of the receiver.

Pull out the desired push button as shown in fig. 9. Reduce the volume to a low value, and tune in the desired local station with the manual tuning knob. The station is correctly tuned in when the clearest tone is heard. Carefully push the button in all the way, then release it.

Adjust the remaining buttons and check all the positions for "repeat" accuracy. Repeat the procedure for any buttons that shift from the correct tuning point.

NOTE: The push buttons on the Thunderbird radio are loosened for adjustment by turning the buttons counterclockwise one turn. They are tightened by turning them clockwise.

c. Minor Repairs.

Minor repair involves mechanical adjustments and

corrections of the tuning mechanism and antenna trimmer and replacement of pilot lights, vibrators, and antenna.

(1) **ANTENNA TRIMMER.** If the antenna trimmer unit will not "peak" the volume when the trimmer knob is rotated in either direction, remove the receiver bottom cover and examine the condenser tuning plate (see fig. 10) for movement while the trimmer knob is rotated. If there is no movement of the tuning plate, the knob screw threads are stripped, and the condenser must be replaced (Major Repair).

(2) **PILOT LIGHT REPLACEMENT.** Remove the receiver from the car, and remove the top cover. The pilot light is then accessible for replacement (fig. 11).

(3) **CLUTCH RELEASE ADJUSTMENT.** To repair inoperative or hard operating push buttons, check the clutch release clearance. The clutch should release when any tuning push button is depressed about $\frac{1}{4}$ inch. The clutch is adjusted by bending the adjusting arm (fig. 12).

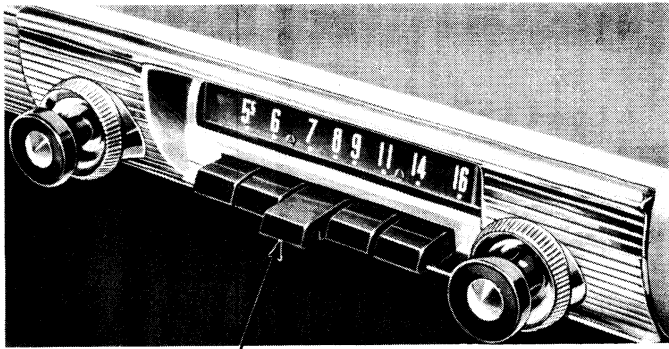

BUTTON PULLED OUT, FOR ADJUSTMENT

7613

Fig. 9—Push Button Adjustment

(4) **TUBE AND VIBRATOR REPLACEMENT.** All tubes and the vibrator may be easily removed once the

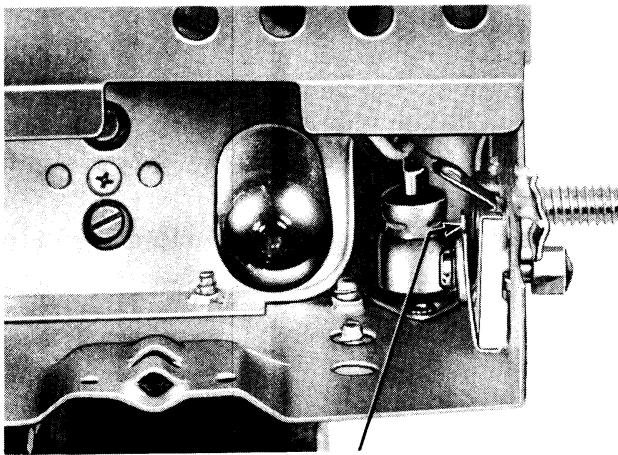

TUNING PLATE

7614

Fig. 10—Antenna Trimmer

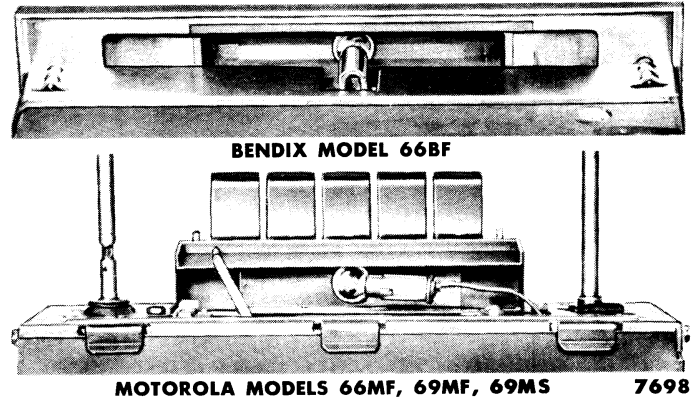

MOTOROLA MODELS 66MF, 69MF, 69MS

7698

Fig. 11—Pilot Light Location

bottom cover is removed (fig. 6). When the new tube or vibrator is installed, be sure that it is firmly seated in its socket. The vibrator can be plugged in only when the prongs are correctly oriented with the socket.

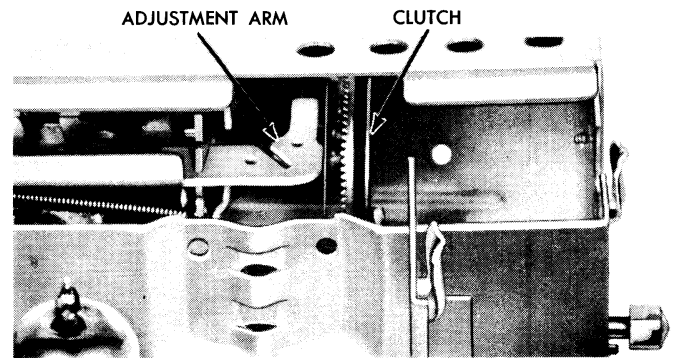

7615

Fig. 12—Clutch Adjustment

3. HEATER

Two heaters are available, a fresh air heater, and a recirculating type heater.

A circuit diagram is shown in fig. 13. Figure 14 shows a disassembled view of the fresh air heater.

a. Operating Principles.

The fresh air heater is designed to function in conjunction with the right-hand duct of the fresh air ventilating system. The heater blower couples to an outlet provided in the right-hand fresh air valve assembly. A valve in the duct is operated by a control located on the instrument panel, allowing the selection of outside air for ventilation or heating, or the recirculation of the air within the car. Two types of temperature control units are used, their operation is as follows:

(1) **CAPILLARY TUBE CONTROL UNIT.** With

this unit the temperature of the heated air is controlled by a capillary tube operated valve that automatically regulates the flow of water through the heater. The capillary tube is located in the plenum chamber. The action of the control unit is regulated by the temperature control lever in the heater control panel.

(2) **BIMETALLIC CONTROL UNIT.** The temperature of the heated air in this unit is controlled by a bimetallic vacuum thermostat valve, located in the plenum chamber that regulates a vacuum operated water valve located on the engine.

These two valves automatically regulate the flow of water from the cylinder block to the heater. The vacuum thermostat valve is operated and adjusted for temperature by the temperature control knob in the heater control panel. When no heat is desired, the

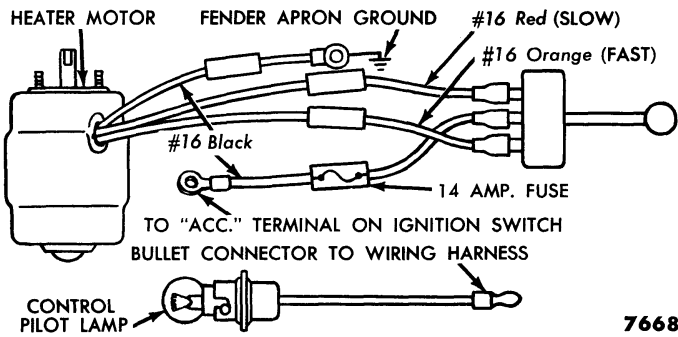

Fig. 13—Heater Circuit

temperature control knob is pushed all the way to the left. This closes the vacuum thermostat valve, preventing water circulation through the heater core.

The defroster control operates a damper in the heater housing. When the defroster is fully on, the damper closes the plenum chamber, causing maximum flow of air to the defrosters. The distribution of air between the defrosters and the plenum chamber is regulated by the position of the "air" control lever between "Heat" and "Defrost."

Two speed ranges are provided for the blower fan by means of a switch and a two-speed three-wire-motor.

An air distributor (plenum chamber) contains numerous outlets that serve as nozzles to direct the air down-

ward to the floor. The air then flows under the front seat and circulates through the entire passenger compartment.

A hinged door in the front of the heater housing provides for a flow of heated air directly to the right front seat for a quick warm up.

NOTE: *This door must be closed for maximum defrosting.*

b. Accessibility.

The fresh air heater consists of a heater unit, motor and blower assembly, heat control units, air distributor, defroster tubes, nozzles, and controls. Individual units of the heating system can be removed with ease if service is required. The heater installation is illustrated in fig. 15.

The dash panel is provided with a cover plate which is removed from the engine compartment side for the heater unit installation. The dash insulator pad has the mounting hole partially pierced, making it necessary to cut only a small portion of the pad to remove it.

The blower housing assembly may be removed to gain added room for spark plug removal. Disconnect

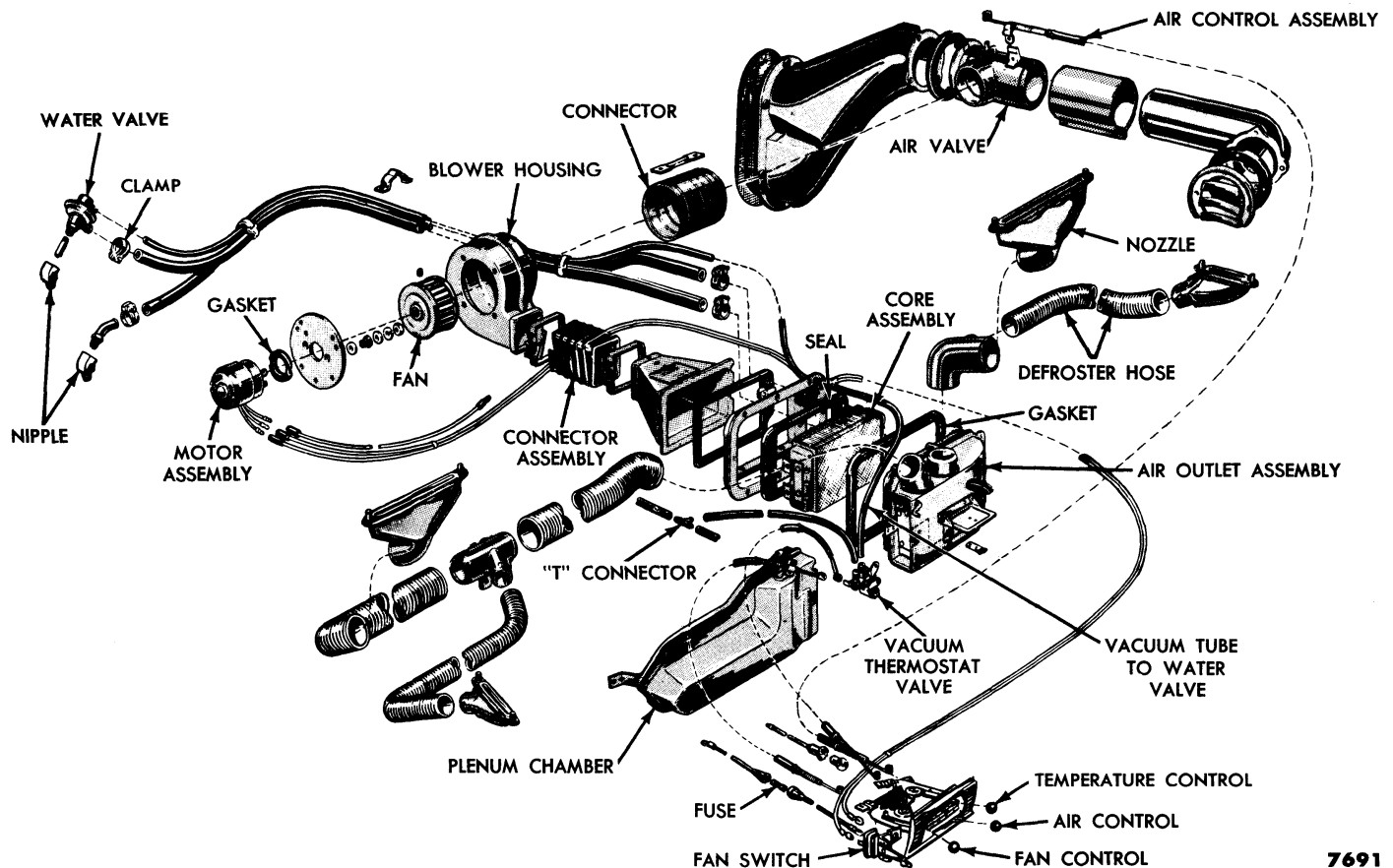

Fig. 14—Fresh Air Heater—Disassembled

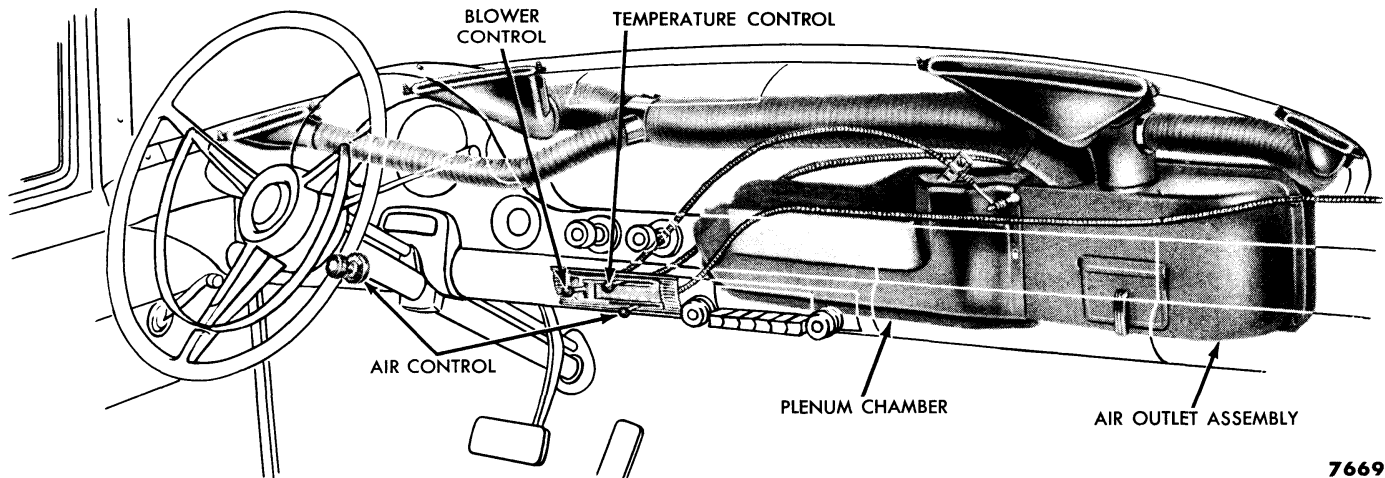

Fig. 15—Heater Installation

7669

one end of the heater to blower air duct connector. To remove the blower assembly, loosen the three mounting bracket cap screws, slide the blower housing and bracket assembly upward to clear the heads of the cap screws and remove the assembly.

The heater control is mounted in the instrument panel to the right of the steering column. To remove the unit, remove the two nuts and mounting clamps. Disconnect the cables; the switch wires, and the pilot light wire from its connector.

The blower switch is attached with two sheet metal screws to the underside of the control unit (fig. 16). Disconnect the wires from the switch, remove the knob from the switch lever and remove the two mounting screws.

Removal and installation of the heater blower motor and fan is accomplished as shown in fig. 17. After installing the blower and fan, be sure that the ground connection is clean and tight.

c. Heater Current Draw Test.

Connect a 0-50 ammeter as shown in fig. 18. The blower motor will operate independently of the control switch, and the current draw of the motor will be indi-

cated on the ammeter. Normal current draw should be 4 to 5 amperes for the high speed position (orange wire). The slow speed current draw (red wire) is 3 to 4 amperes.

d. Heater Control Adjustment.

The upper lever of the control assembly is connected to the thermostat on the heater. The lever must be adjusted so that it closes the valve when the lever is $\frac{1}{8}$ to $\frac{3}{16}$ inch from the left-hand end of the slot (fig. 19).

The lever is adjusted on the bimetallic type control unit by positioning the control cable in the clamp located on the heater housing. Loosen the cable clamp on the heater housing, and set the thermostat valve in the closed position (all the way down). Position the cable so that the "temperature" lever is $\frac{1}{8}$ to $\frac{3}{16}$ inch from the left end of the slot, and tighten the clamp.

The "temperature" lever on the capillary tube type control is adjusted by positioning the control cable in the clamp located on the temperature regulator valve which is located above the heater unit. Loosen the cable clamp on the regulator valve, and set the regulator valve in the closed position (all the way over to the right). Position the cable so that the "temperature"

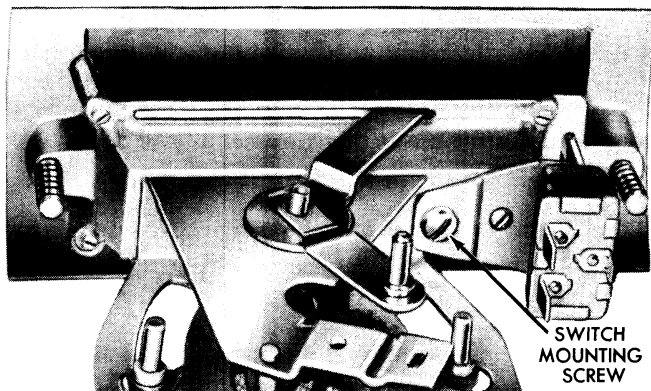

7670

Fig. 16—Blower Switch Removal

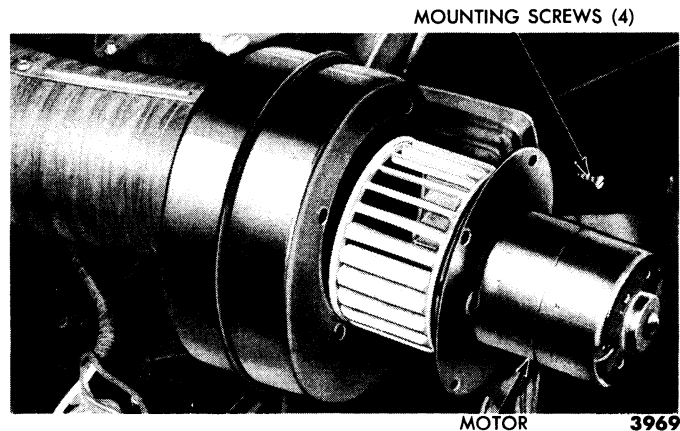

MOTOR

3969

Fig. 17—Heater Motor Blower Removal or Installation

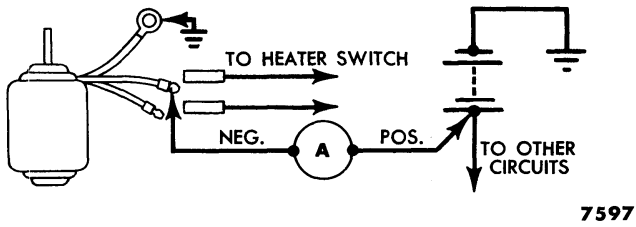

Fig. 18—Heater Motor Current Draw Test

lever is $\frac{1}{8}$ to $\frac{3}{16}$ inch from the left end of the slot, and tighten the clamp.

The middle lever controls the damper in the right-hand air duct. It should close the damper when the lever is $\frac{1}{8}$ to $\frac{3}{16}$ inch from the left end of the slot (fig. 19). The damper now permits the heater blower to recirculate the air inside the passenger compartment (fig. 20). With the lever in the "ventilate" position, the damper

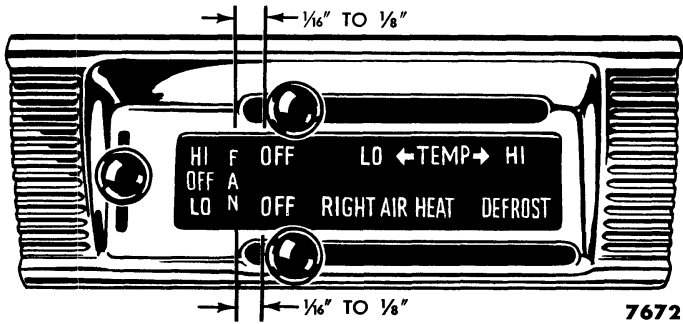

Fig. 19—Heater Control Lever Adjustment

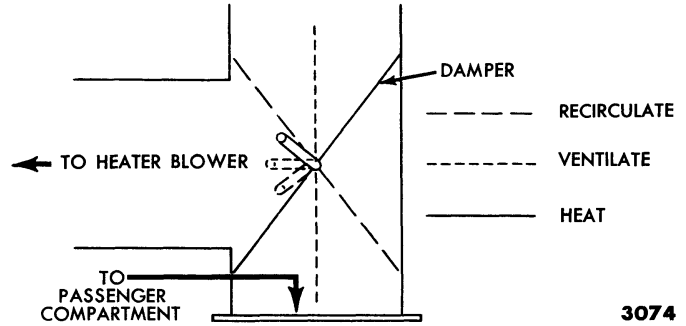

Fig. 20—Damper Positions Controlling Air Flow

permits outside air to enter the car interior through the right-hand air duct. When the lever is moved to the "heat" position, the outside air is forced through the heater and into the car interior. When the lever is moved to the "defrost" position, the heater air is allowed to flow through the defroster tube and nozzles to the windshield. Make certain that the damper in the heater housing completely closes the opening to the defroster tubes when the air control lever is in the "heat" position. This is accomplished by adjusting the cable in the clamp on the front side of the heater housing.

NOTE: When the damper is in the "ventilate" or "heat" position, it may be necessary to open a ventilator or window to allow complete circulation of the outside air through the passenger compartment.

4. WINDSHIELD WIPER

The windshield wiper is shown in fig. 21. The wiper motor is mounted separately from the pivot shaft assemblies.

a. Disassembly.

If service is required on the motor assembly, control assembly, or pivot shaft assemblies, they may be re-

moved separately. To remove the motor assembly, disconnect the vacuum line, then remove the two linkages from the motor. The motor can be taken off its mounting bracket by removal of the two mounting screws. Loosen the screw holding the control cable to the motor, then remove the cable from the motor. It is suggested that on cars equipped with a radio, the radio be removed before attempting to remove the wiper motor.

Since the wiper is serviced as an assembly, it is recommended that no further disassembly of the motor be attempted.

The control assembly may be removed from the instrument panel by removing the bezel nut after loosening and removing the control knob.

The pivot shaft assemblies are removed by first lifting off the wiper arms and blades. Remove the pivot attaching nuts, spacers and washers. The pivot assemblies may then be removed.

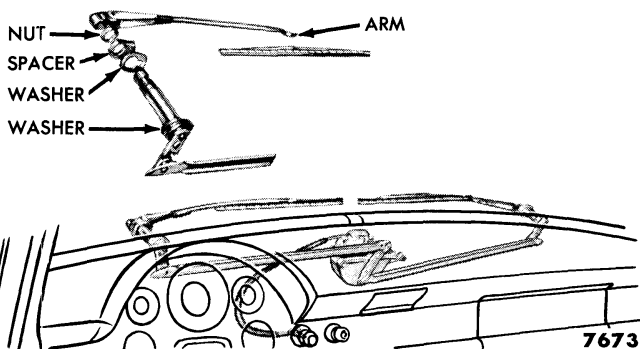

Fig. 21—Windshield Wiper Installation

b. Assembly.

Attach the control cable to the motor. Assemble the motor to the car (fig. 21). Insert the pivot shafts through the mounting holes. Install the washers, spacers, and nuts. Connect the links to the motor, then install the retainer clips. Install the instrument panel control

to the instrument panel. Assemble the control knob to the shaft.

Run the engine momentarily, with the wiper control OFF, to bring the pivot shafts to their rest position. Install the blades so that they are flat against the lower edge of the windshield.

5. MISCELLANEOUS ACCESSORIES

a. Clock.

Adjustment of the clock can be made by turning the adjustment on the front of the clock housing. If the clock runs slow, rotate the adjustment screw toward the "F" mark; if it runs fast, move the adjustment screw toward "S."

To replace the clock, disconnect the clock wire. The clock assembly can now be removed from the rear of the instrument panel by removing the three mounting screws.

b. Turn Indicator.

The material given on the turn indicator is to aid in the service of existing installations and as a supplement to the instruction sheet which accompanies each indicator unit parts kit.

Factory installed indicators have the necessary wires incorporated in the wiring cables. Dealer installed indicators will have only a portion of the wiring already installed.

Figure 22 shows the turn indicator wires connected to the existing wiring.

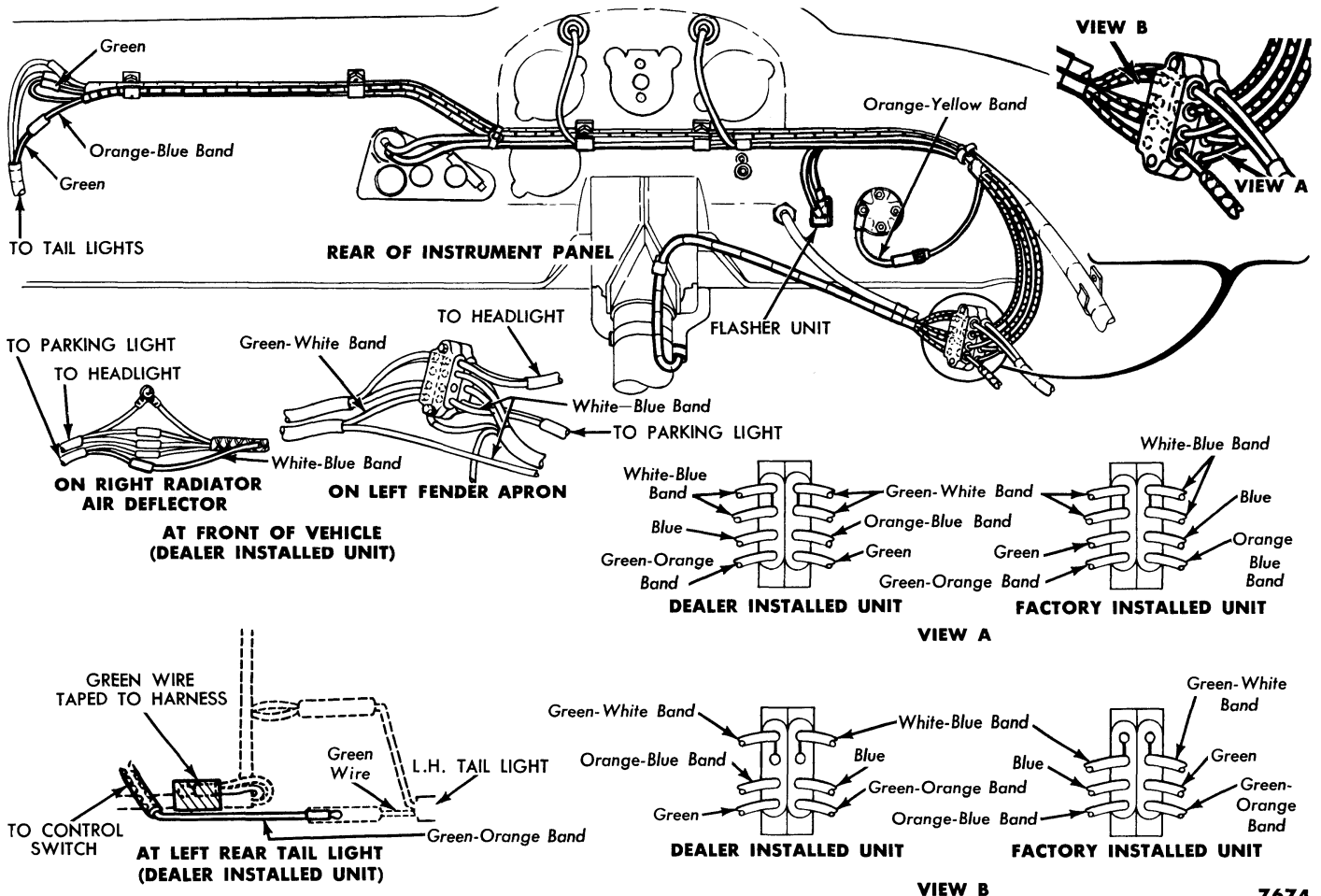

Fig. 22—Connections of Turn Indicator to Existing Wiring

Part FOUR

BODIES

Chapter

I

Body Construction and Maintenance

Section	Page
1 Construction Details and Sealer Application	271
2 Body Alignment	278
3 Quarter Panel Repair	279
4 Fiber Glass Repair—Thunderbird Hard Top.....	281
5 General Body Maintenance	282
6 Paint Refinishing	284

This chapter presents procedures of a general nature for servicing bodies. This chapter likewise presents body maintenance instructions.

Automotive body repairing should be done by persons specially trained in this type of work. A thorough

understanding of the operation of the tools and equipment required and a knowledge of the internal construction of the various body types is essential. With this knowledge, the best method of doing the job can readily be determined.

1. CONSTRUCTION DETAILS AND SEALER APPLICATION

Body construction details are clearly presented here by sectional views of all major parts of the body (figs. 1 through 13). In cases of complete panel replacement or where only a portion of a particular panel requires replacement, it is very helpful to know where and how that particular panel is fastened. In some cases, the sec-

tional views apply to more than one body. For further details of basic body components, consult the Body Parts Catalog.

a. Dust and Water Leaks.

The sectional views show the various locations where

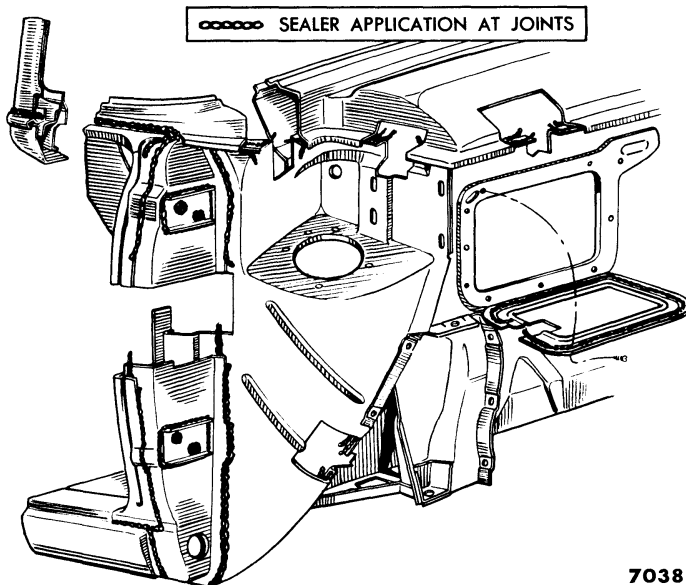

7038

Fig. 1—Front Body Pillar and Cowl Side Panel Construction and Sealer Application—All Models

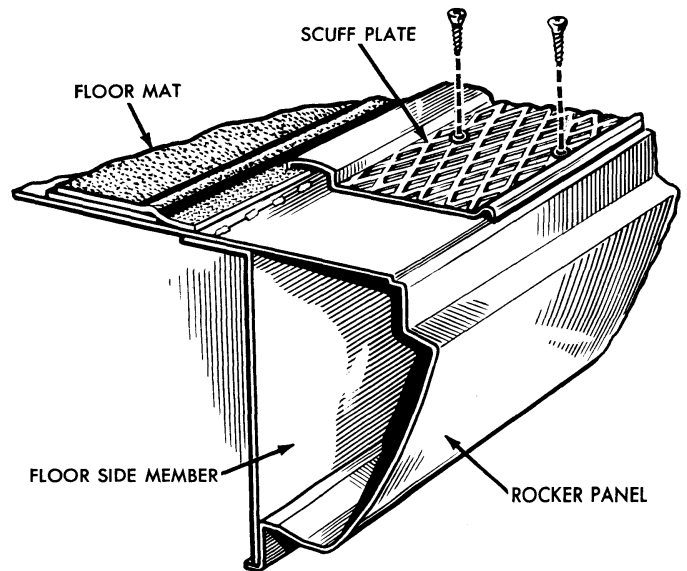

7130

Fig. 2—Rocker Panel and Scuff Plate

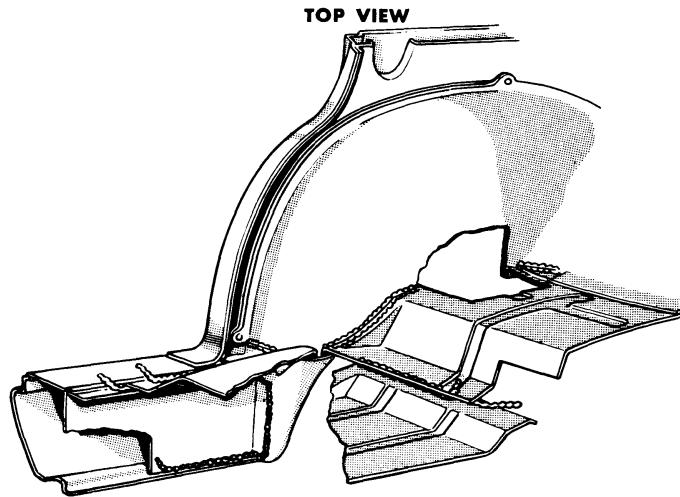

SEALER APPLICATION AT JOINTS

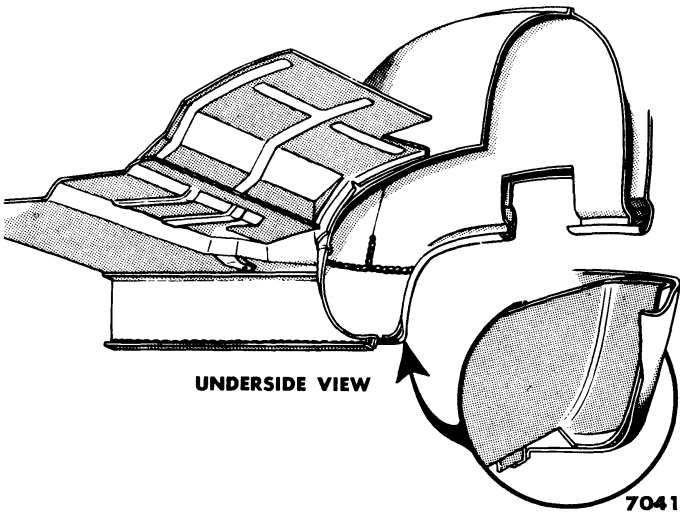

Fig. 3—Wheelhouse Panel to Floor Pan Construction and Sealer Application—All Models

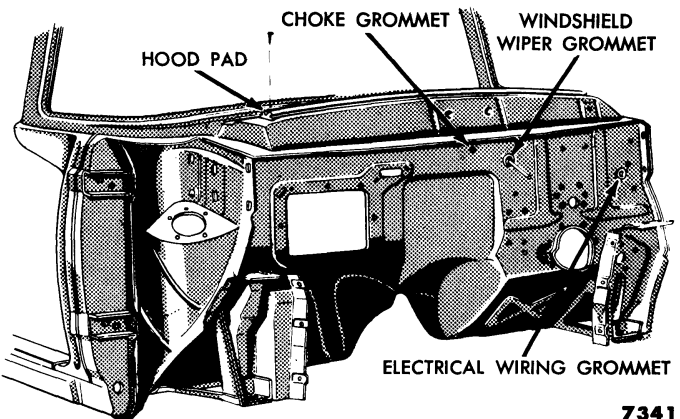

Fig. 4—Dash Panel Construction and Grommet Locations

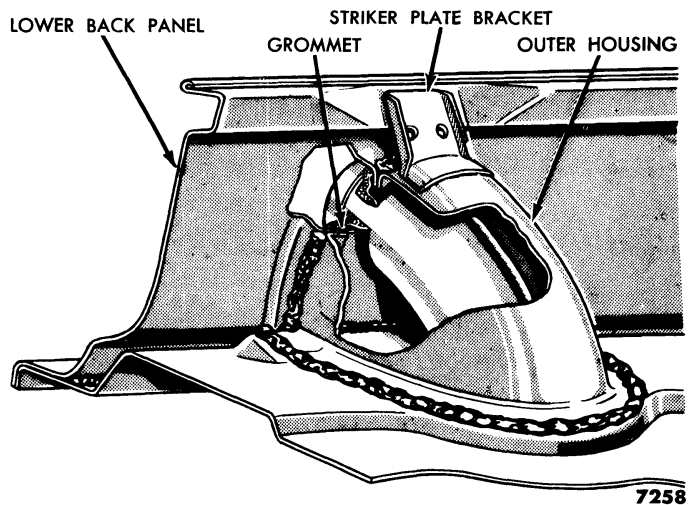

Fig. 5—Fuel Tank Filler Neck Housing Construction and Sealer Application—All Models Except Ranch Wagon, Country Squire, and Courier

sealers are used in the manufacture of the body. These sealer locations should be considered when checking for dust or water leaks. It should be remembered that the forward motion of the car creates a slight vacuum within the body, particularly if a window or ventilator is partially open. Any unsealed crevice or small opening in the lower section of the body will permit air to be drawn into the body. If dust is present in the air, it will follow any path taken by the air from the point of entry into the passenger and luggage compartments. Dust may work its way into the hollow, box-type, rocker panel which extends along the edge of the floor below the doors. Dust accumulates in the rocker panel, and may eventually work its way to the rear body pillar, or kick

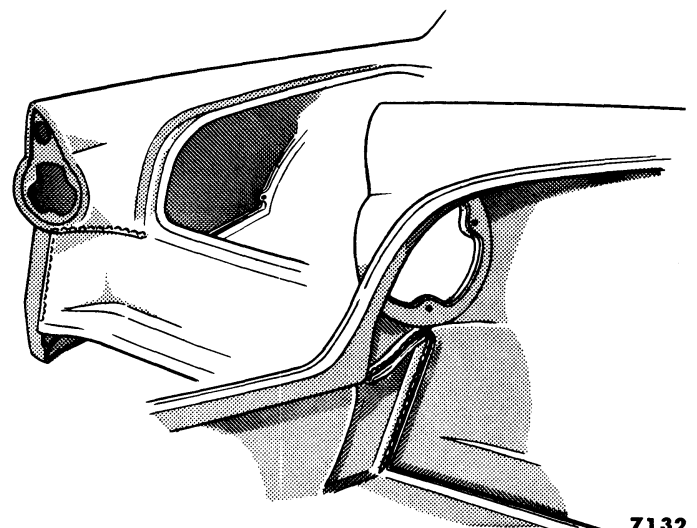

Fig. 6—Quarter Outer Panel, Extension Panel and Lower Back Panel Construction and Sealer Application

up and follow the contour of the wheelhouse into the luggage compartment. In some instances, it may filter upward and enter between the rear quarter window garnish moulding and the glass on the inside of the body. Also, on Fordor sedans dust has a tendency to rise up through the center pillar and come out through openings along the pillar, or work its way above the headlining trim, and eventually seep through the material.

To eliminate dust leakage, determine the exact point at which the dust enters. As explained above, the point of entry is often deceptive in that the dust may enter at one point then follow the passages, formed by interior trim, to another point.

Under certain conditions, water can enter an automobile body at any point where dirt or dust can enter. Any consideration of water leakage must take into account all points covered under dust leaks.

b. Locating Dust Leaks.

To determine the exact location of a dust leak, remove the following trim from the car:

- (1) Cowl trim panel.
- (2) Quarter trim panel.
- (3) Rear seat back and seat cushion.
- (4) Luggage compartment floor mats, spare wheel, and cardboard side trim panel.
- (5) Center pillar trim on Fordor sedans.
- (6) Scuff plates.

After removing the trim, road test the car on a dusty road to obtain a definite dust pattern at the point of leakage. The entrance of dust is usually indicated by a pointed shaft of dust or silt at the point of entrance.

After the road test, check for indications of a dust pattern around the door opening, cowl panel, lower part of the quarter panel, and in the luggage compartment.

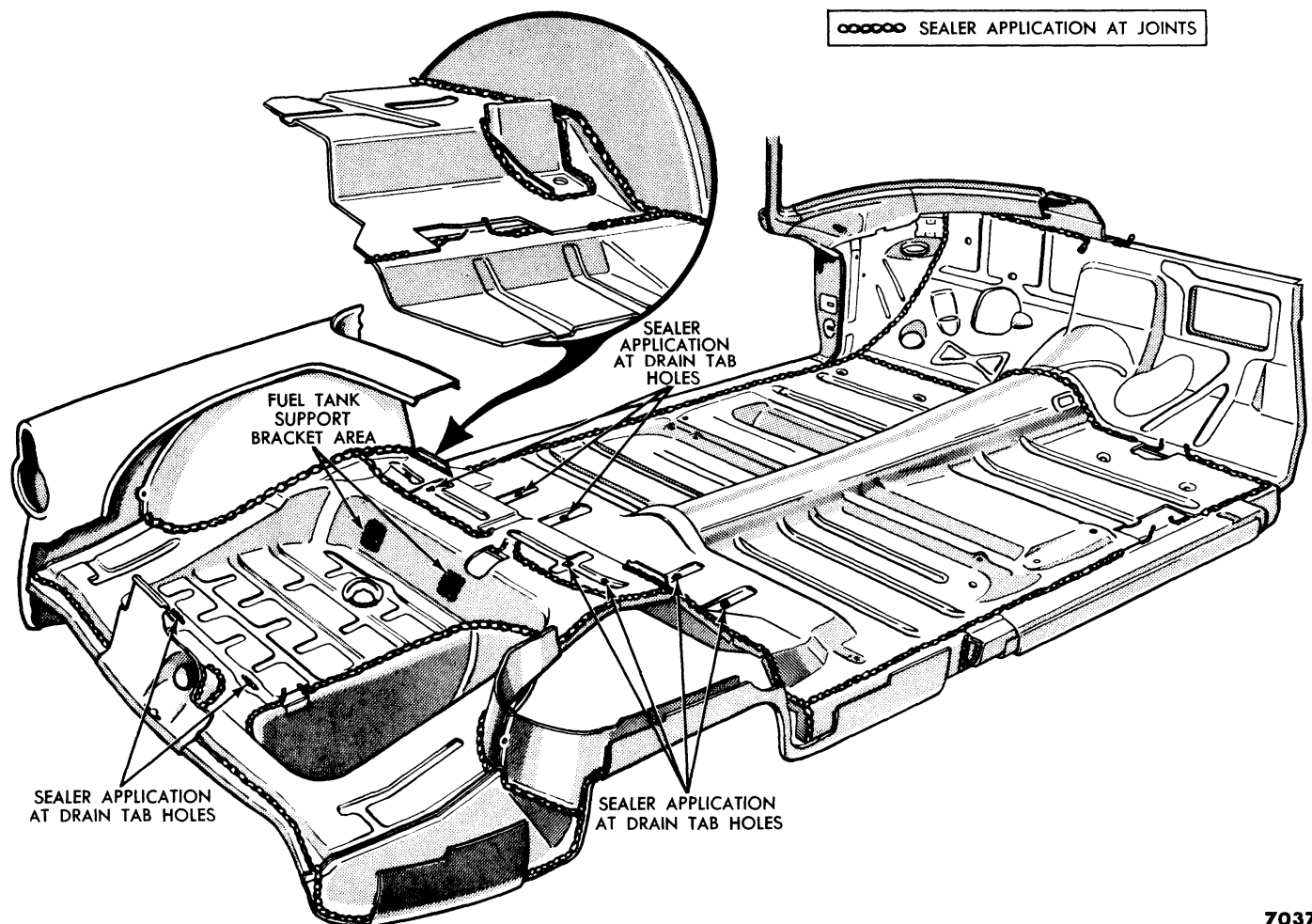

Fig. 7—Floor Pan Construction and Sealer Application—Tudor shown—Fordor typical

c. Types of Sealers and Application.

A wide variety of sealers are used by the manufacturers. Since it would be difficult to stock all of these sealers, the following all purpose sealers have been selected for service use. The method and points of application are given under each sealer type.

(1) RUBBER CEMENT (8A-19552-B).

This cement is a quick-drying, strong, adhesive material. It is designed to cement weather stripping to doors, bodies, deck lids, cowl ventilators, windshield glass, and the surrounding metal. Windows and windshields which are set in rubber can be effectively sealed against leakage by flowing cement into affected areas.

Clean all grease, dirt, and old sealer from the surfaces to be cemented. Wash the surfaces thoroughly with a rag moistened with clean gasoline or cleaner's naphtha. For best results, apply a medium coat of cement to both surfaces, allow it to dry until tacky, then press both surfaces firmly together.

(2) BODY SEALER (M-5335-B).

This sealer is of a medium-heavy viscosity, and it has an asphalt base with an asbestos filler. This body sealer can be applied with a gun, and it is used at any joint where there is movement or flexing between two metal surfaces.

(3) BODY SEALER (M-5397-B).

This sealer has a plastic base with an asbestos filler and is commonly known as "permagum." It is used on spot-weld holes around moulding clips, or between two surfaces not properly sealed by a gasket. Apply the sealer with a putty knife.

d. Floor Pan Plugs and Grommets.

As shown in figs. 7, 11, 12, and 13 many plugs and grommets are used in the floor pan and dash panel. The floor pan plugs seal the various body bolt access holes. If any plugs are missing or improperly installed, a dust or water leak may result. This also applies to the grommets used on the dash panel. When dust or water leaks

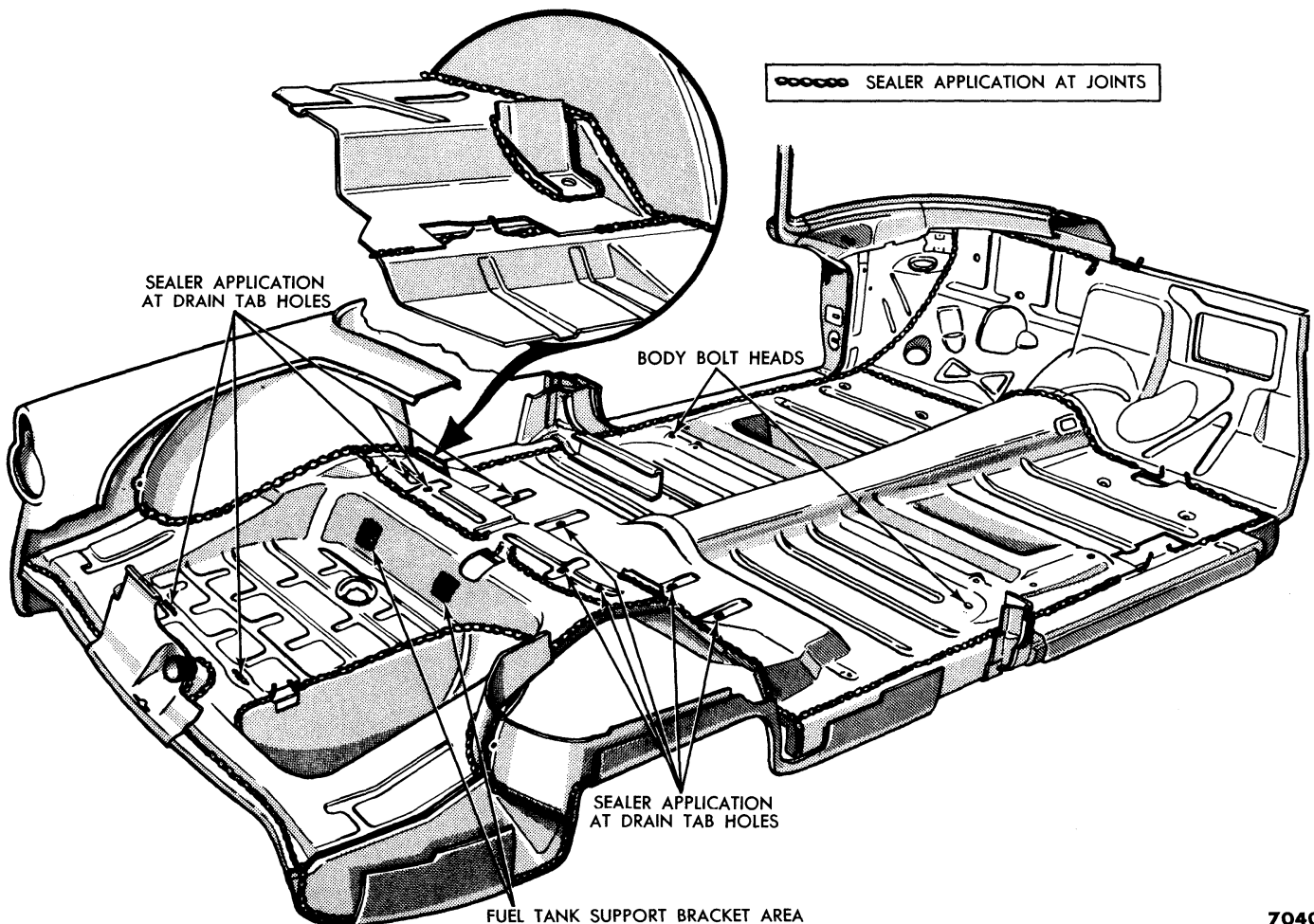

Fig. 8—Floor Pan Construction and Sealer Application—Victoria and Convertible

are evident, these plugs and grommets should be checked for proper installation.

e. Drain Holes.

Drain holes are located on the underside of each rocker panel and on the underside of each quarter panel. If these holes become clogged with mud or road tars, water will collect inside the panels, and rust out the sheet metal from the inside. A sound of sloshing water in the rear quarter panel is an indication of this condition. Check the drain holes every 1000 miles. Clear the drain holes of dirt and foreign material with a punch.

f. Body Undercoating.

Undercoating is highly resistant to abrasion and corrosion and is designed to give maximum sound deadening. When properly applied, it is an excellent sealer for dust and water leaks, and in many cases, it can be used effectively to treat pin-point holes and body welds.

Two types of undercoating are recommended: the

**FRONT VIEW ABOVE WINDSHIELD
VICTORIA**

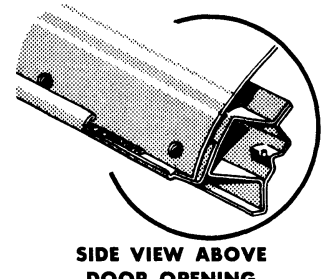
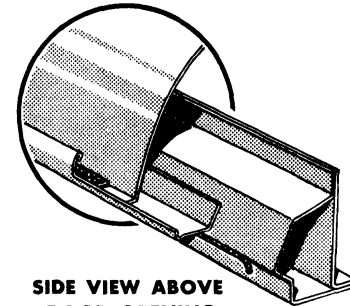
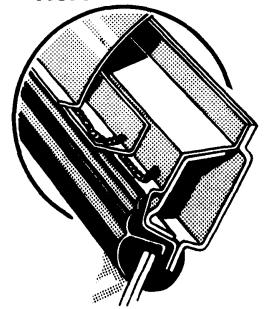
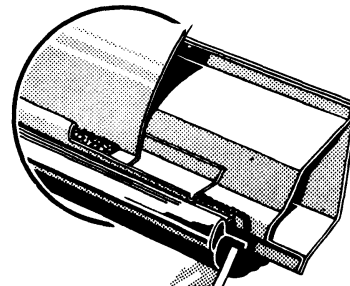

**Fig. 10—Roof Panel, Roof Rail, and Drip Moulding
Construction and Sealer Application**

SEALER APPLICATION AT JOINTS

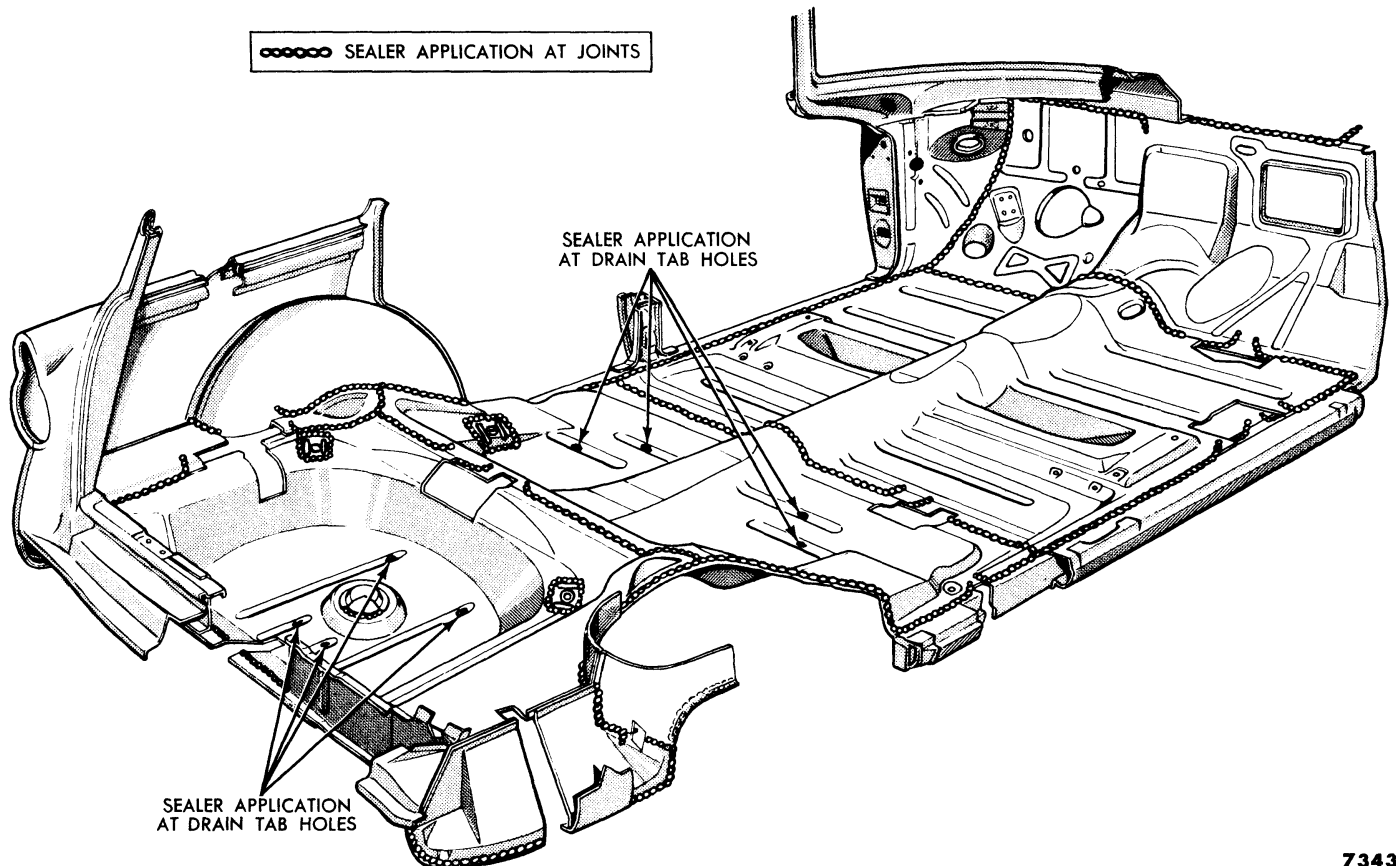

**Fig. 9—Floor Pan Construction and Sealer Application Country Squire
Shown, Ranch Wagon and Courier Typical**

regular solvent type (B5A-19515-A); and the water emulsion type (AB-19515-A). The latter is used in areas where local and state regulations restrict the use of the solvent type undercoating.

(1) **PREPARATION OF THE VEHICLE.** Undercoating must be applied to a **CLEAN, DRY** surface. If the car is new, simply wipe the surface to be undercoated with a dry rag. If it is old, remove mud and grease with a wire brush, or steam clean the vehicle. Undercoating will adhere to either bare metal or painted surfaces, even if slightly dusty or oily, but will not adhere to a wet surface. After a vehicle is washed or steam cleaned, make sure all surfaces are **THOROUGHLY DRY**. Use an air hose to save time and improve the quality of the job.

Place the truck on a free-wheel hoist, and remove all four wheels. Provide plenty of light.

Examine the body bolts, and make sure they are tight on both new and old cars. Mask off any parts of the car that are likely to be exposed to overspray.

CAUTION: *Be sure to mask the drain holes in the quarter panels.*

(2) **SPRAYING.**

CAUTION: *When spraying with the solvent-type material, observe the same precautions as when spraying with paint. Do not permit welding operations or smoking in the spray areas.*

Spray undercoating on all underbody sheet metal surfaces, frames, braces, gas tank, and under the fenders.

Spray the center underside of the fenders a little heavier to provide additional protection from objects thrown up by the tires.

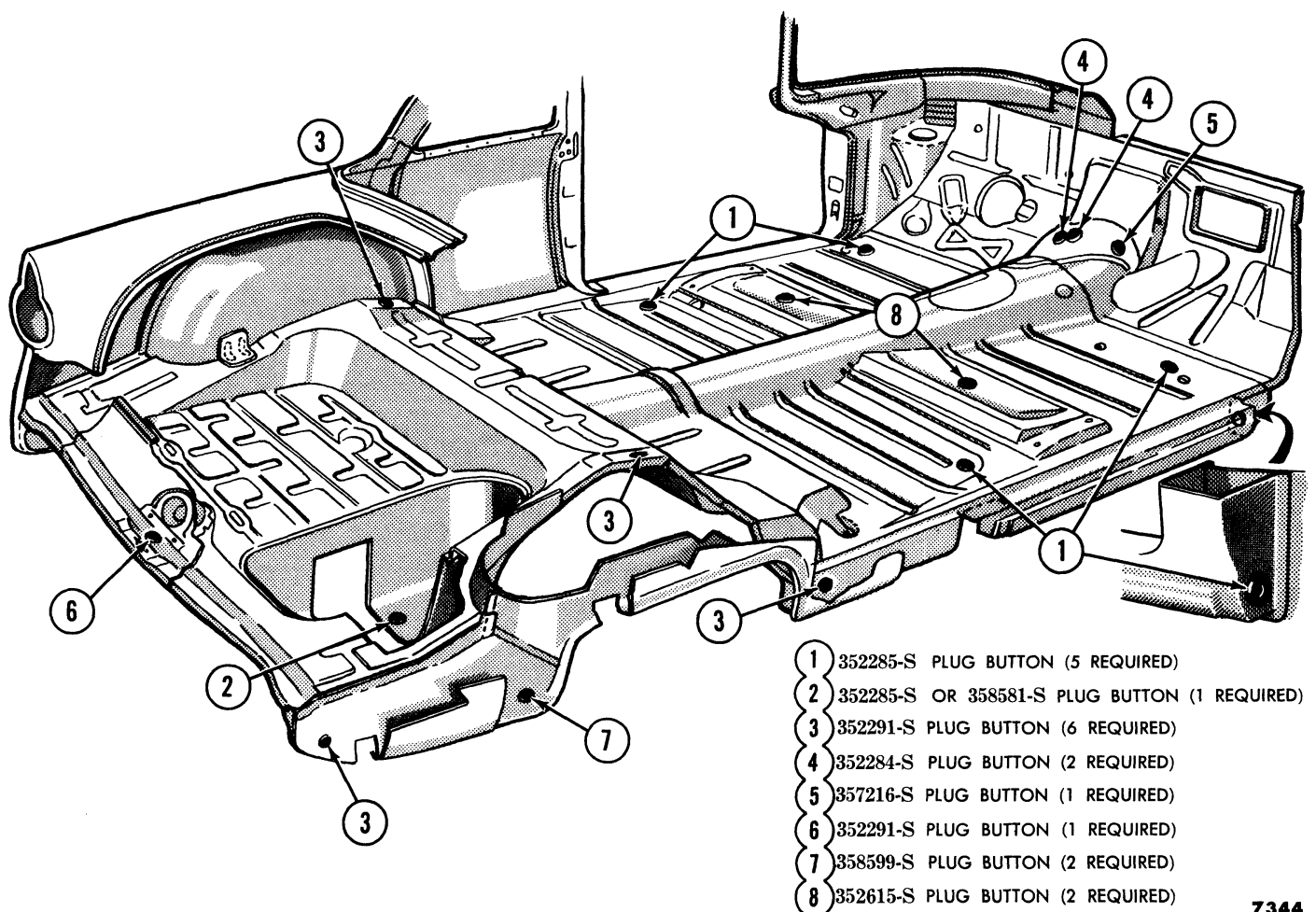

7344

Fig. 11—Location of Floor Pan Plug Buttons and Grommets—Tudor and Fordor

Spray the hard-to-reach parts first, with normal pressure on the material but low atomizing pressure, then increase the atomizing pressure and spray the balance of the car.

CAUTION: *Do not spray the brake mechanism, oil pan, differential, transmission, lubrication points, drive shaft, exhaust pipe and muffler, hood, or any working parts.*

Adjust and operate the spraying equipment according to the manufacturers directions.

After spraying, be sure to clean accidentally applied undercoating from all working parts. If the solvent type material is used, dip a cloth in kerosene or solvent, and wipe off the unwanted material. Water emulsion-type undercoating can easily be cleaned from surfaces before the material dries by washing with water and then wip-

ing with naphtha.

CAUTION: *As a final step, remove the masking tape and be sure that all drain holes are free of obstructions.*

(3) REPAIRING UNDERCOATED SHEET METAL.

When repairing undercoated sheet metal, rough out the damaged portion, then apply moderate heat to the outside of the panel. This will soften the undercoating so that it can be scraped off with a putty knife. Remove any remaining material with a solvent.

Apply undercoating to the repaired metal with a putty knife or paint brush.

CAUTION: *Do not apply heat on freshly applied undercoating.*

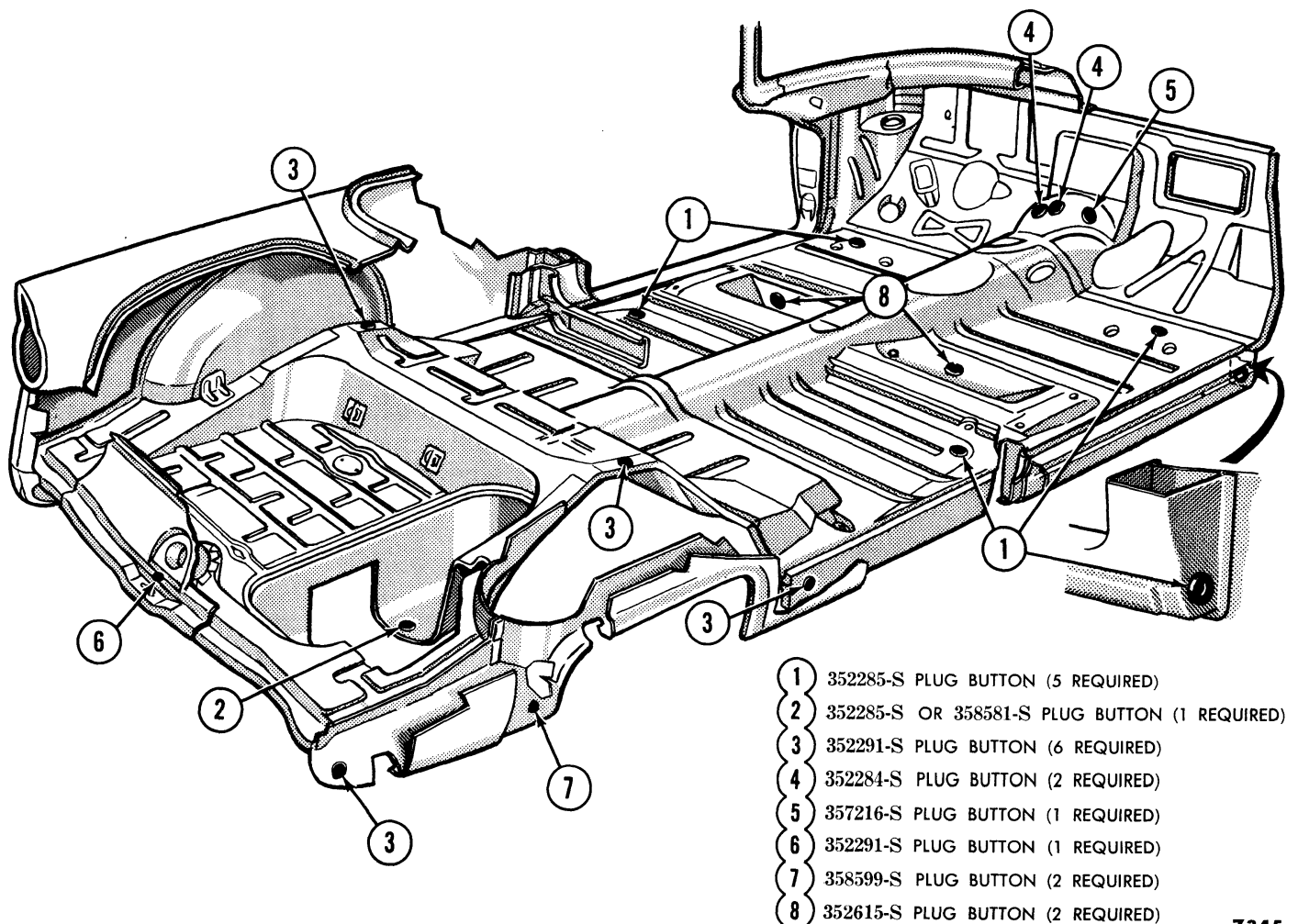

**Fig. 12—Location of Floor Pan Plug Buttons and Grommets—
Convertible and Victoria**

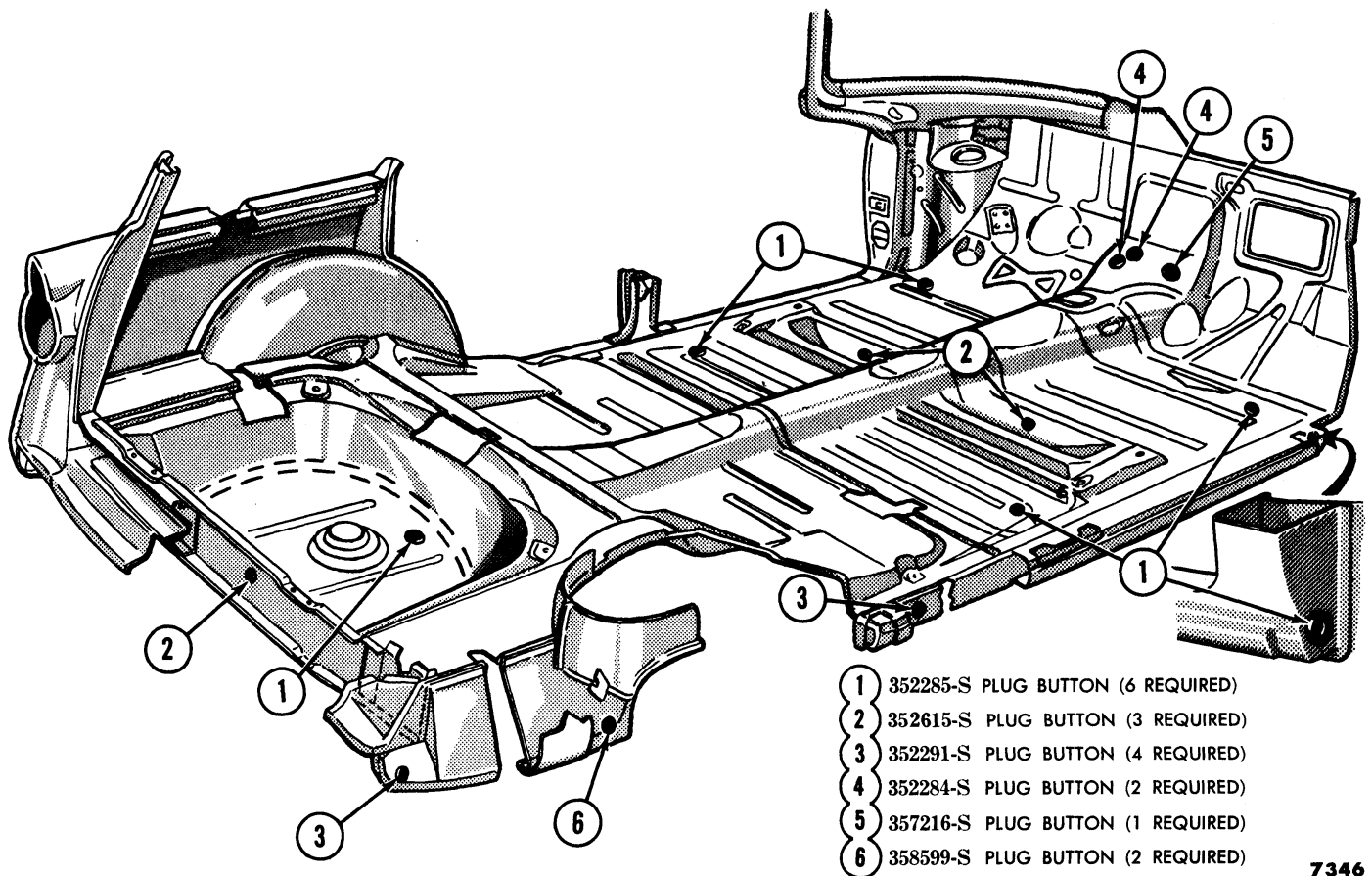

**Fig. 13—Location of Floor Pan Plug Buttons and Grommets
All Station Wagon Models**

7346

2. BODY ALIGNMENT

When checking alignment of a body that is badly damaged, be sure that all necessary frame corrections have been made before attempting to align the body.

Rough out badly damaged areas before taking measurements for squaring up a body. Remove glass to prevent breakage. In severe cases, reinforcement brackets and other inner construction may have to be removed or cut to permit restoration of the outer shell and pillars without excessive strain on the parts. Straighten, install, and secure all such parts in place before attempting to align the body.

In cases of severe or sharp bends, it may be necessary to use heat. Any attempt to cold-straighten a severely bent bracket may cause ruptures of the welds (if any) and may also cause cracks in the bent part. Never heat the area more than a dull red.

a. Checking Body for Misalignment.

To align or square up a body, take two opposite diagonal measurements between the two front pillars,

the center pillars and the rear pillars. Use a measuring tram for these measurements. Take the measurements between reference points such as crease lines or weld joints which are diagonally opposite each other on the two pillars being measured. Since all measurements should be made from the bare metal, remove all interior trim from the checking points.

In some cases, it is difficult to obtain proper body alignment when repairing a body that is damaged on both sides. In these cases, horizontal and vertical measurement can be taken from a body of the same model and body style. Once these basic dimensions are taken and established on the damaged body, alignment can be made by diagonal measurements taken from the measuring points on the two pillars.

When two opposite diagonal measurements are not the same, the body should be forced in the direction of the short diagonal. The distance to force that part of the body will be a little more than one-half the difference in the two diagonals. To compensate for "spring-back," the portion of the body being aligned should be forced

approximately one inch past the required distance.

Do not attempt to correct any serious misalignment with one jacking operation. This is particularly true if other sections of the body also require aligning. Align each section proportionately until the proper dimen-

sions are obtained.

Door openings are checked in the same manner as the body. Horizontal, vertical, and diagonal checking points are established on all four sides of the door opening that is being measured.

3. QUARTER PANEL REPAIR

The rear fender is an integral part of the quarter panel, and is in no way a separate or removable unit.

Although the rear fender is not removable, this does not necessarily mean that the panel cannot be replaced. With proper equipment, an experienced body repair man can replace, in whole or in part, a damaged area by one of three methods: first, repair and use the original panel; second, cut out the damaged area and replace with a section of a repair panel; or third, replace the complete quarter panel.

a. Service Panels.

In cases where only a portion of the quarter panel requires replacement, one service quarter panel is used on all models. If the car is damaged to the extent that a complete panel replacement is necessary, complete service panels are available under separate part numbers for tudor, fordor, convertible and victoria models.

Figure 14 illustrates the various quarter panel assemblies used on a particular model as well as the service panel used on the models where only a portion of the panel requires replacement. If the complete quarter

panel requires replacement, fig. 14 will also assist in locating the hidden weld joints which fasten the quarter panel to the body.

b. Panel Repair Procedure.

The following procedure is one of several methods that can be used for cutting out and replacing a portion of the quarter panel. Although this procedure is used here for quarter panel repairs, it can be applied to other sections of the body as well.

Rough out and shape as much of the damaged area as possible. Measure the piece of metal to be cut out (fig. 15). These measurements should be taken from a definite point, such as a moulding or bead.

Make the corresponding measurements on the service panel. Be sure measurements are taken from the same points. Scribe a line around the area to be cut from the service panel (preferably straight-line cuts).

Drill a 1/4-inch hole at any one corner of the scribed line as a starting point for cutting. Use a suitable cutting tool and cut the new piece out along the scribed line.

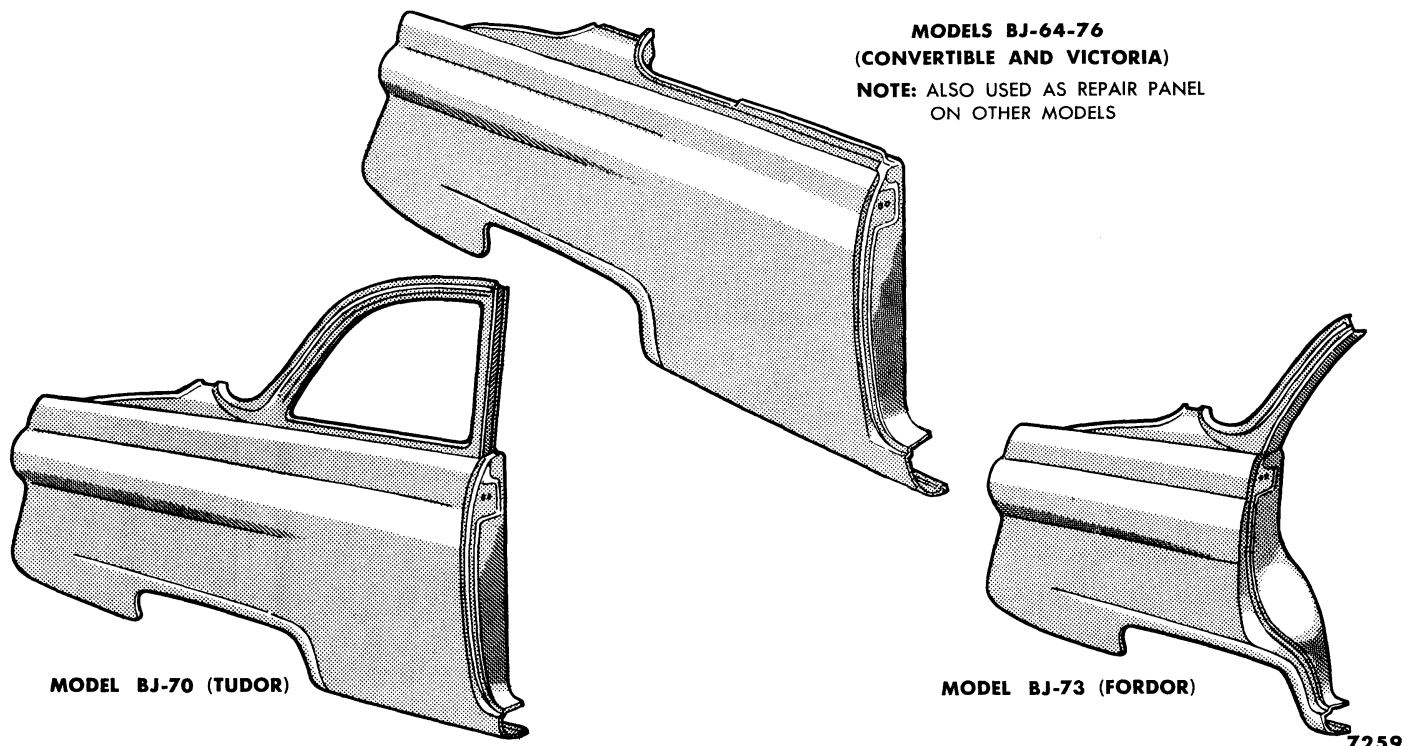

Fig. 14—Service Quarter Panels

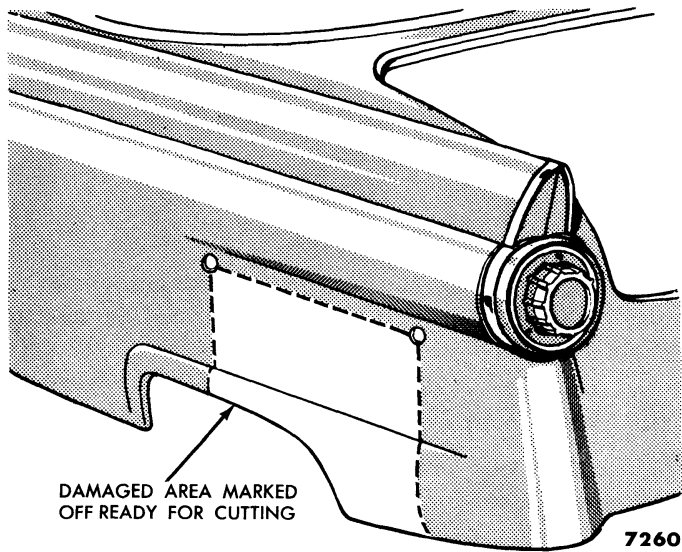

Fig. 15—Damaged Area Ready for Cutting

Straighten the edge of the piece that was cut out, and position it over the damaged area as a template. Secure the cut-out section of the service panel over the damaged area of the body, and scribe a line around the panel. Cut out the damaged area.

NOTE: *If the piece to be replaced is at the pillar post or at any point where the panel is spot-welded to other parts of the body, such as the reinforcement body side lower edge or wheelhousing assembly, the damaged piece should be split at the weld if possible. To split a spot-weld, drive a sharp chisel between the two pieces of metal at the weld. In difficult cases, a spotweld may be split by drilling a 1/4-inch hole into the center of the weld.*

Straighten the cut edge on the panel. Fit the service panel portion into the cut-out area in the body panel. Be sure that the two panels do not overlap. Tack-weld

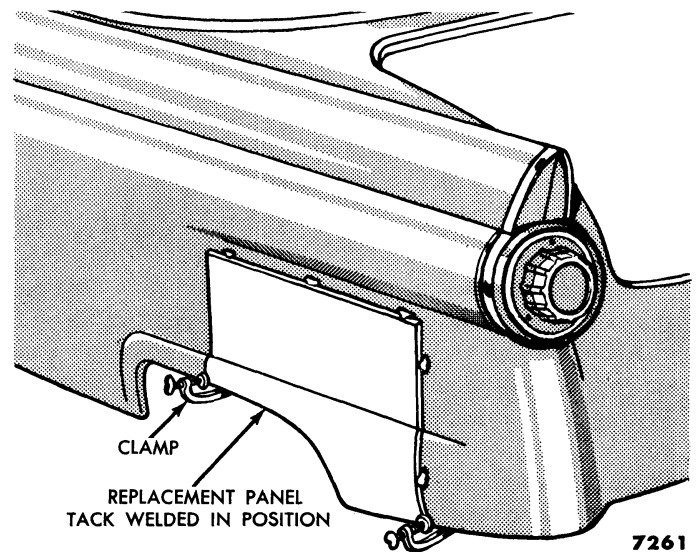

Fig. 16—Service Panel Tack Welded in Position

at intervals as shown in fig. 16, then make a continuous weld around the two pieces. Weld about 6 inches at a time (Step 1, fig. 17). Stagger the welds to prevent excessive distortion.

Hammer the weld below the contours of the surface (Step 2, fig. 17) not more than 1/16 inch with a grooving dolly.

Metal-finish the repaired area and file it smooth, taking care to produce the correct contour (Step 3, fig. 17).

Grind the welded area clean, and tin (Step 4, fig. 17).

Fill in with solder (fig. 17), taking care that sufficient solder is applied so that the final metal finish will not have indentations (Step 5, fig. 17).

Metal-finish the panel to prepare it for painting (Step 6, fig. 17).

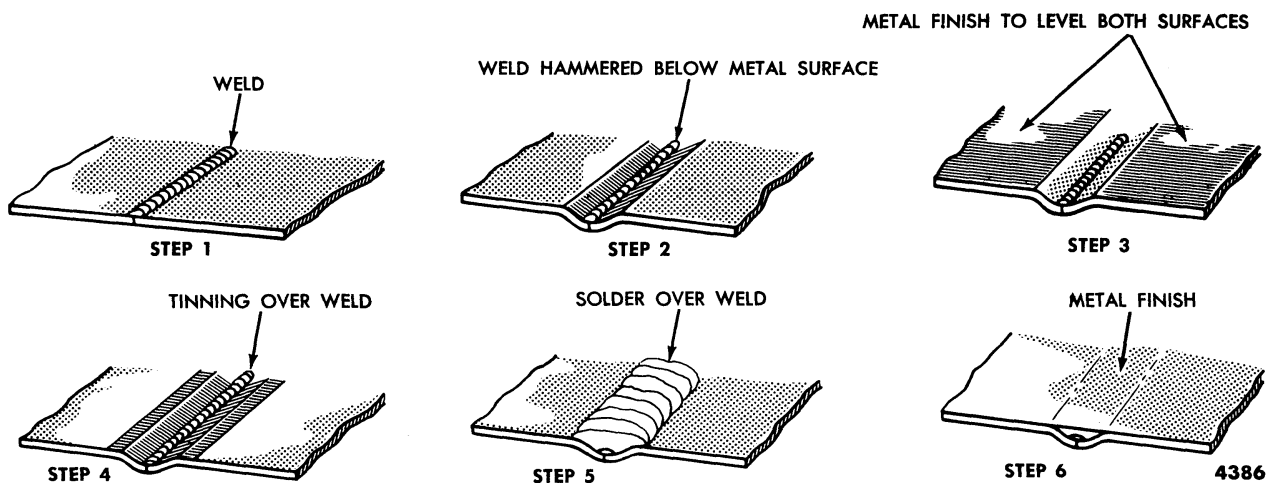

Fig. 17—Typical Metal Finishing Operations

4. FIBERGLAS REPAIR—THUNDERBIRD HARD TOP

A procedure has been developed for the repair of fiberglas such as that used on the Thunderbird hard top. This procedure will cover cracks, splintered edges, or sizeable holes in the fiberglas. A repair kit (B5S-4050231-A) is available which includes the materials listed in Table 1.

Before repairing the fiberglas, both sides of the roof panel must be prepared to receive a patch and filler. After the panel has been properly prepared, a Fiberglas cloth patch is installed on the inside surface of the panel to form a base for the filler which is forced into the hole or fracture from the outer side of the panel. After repair, the outer surface of the panel is re-finished. The following paragraphs give detailed instructions for carrying out these procedures:

a. Safety Precautions.

In some cases epoxy resins will cause a skin irritation or a rash. It is advisable to apply a protective cream, such as Ply No. 9, to the hands and to use rubber gloves when handling the resin and hardener.

Any resin on the hands, clothing, or tools should be removed with lacquer thinner before the resin starts to jell or harden. Since lacquer thinner is very inflammable, it is important to use caution when handling this material. The resin mixes may produce toxic fumes and should be used only in well ventilated areas. If it is necessary to grind or polish the resin repaired areas, a respirator must be worn to avoid inhaling the resin dust.

b. Preparation of Mixtures.

Two mixtures are used in the repair procedure. Mixture No. 1, which is used for applying the fiberglas patch to the interior surface of the roof top or panel, consists of 7½ tablespoons of Epoxy Resin to 1 tablespoon of hardener. Mixture No. 2, which is used for filling the hole from the top side of the panel, consists of 3 tablespoons of Glazing Putty to 1 teaspoon of hardener. Neither of these mixtures should be prepared

Table 1—Fiberglas Repair Kit

Quantity	Name
1	8 ounce container—Epoxy Resin
1	4 ounce container—Hardener
1	8 ounce container—Glazing Putty
1	12 x 48-inch piece—Fiberglas Cloth
6	Paper Cups

until after the damaged area is ready to receive them. The working time for both mixtures is approximately 35 minutes. If allowed to set for a longer period, the mixture will begin to harden and, thus, become difficult to apply.

c. Preparation of Fiberglas.

Remove the hard top from the car, and remove the headlining from the damaged area to permit access to the inside surface. Grind or file all cracked or splintered materials away from the hole on both the inside and outside surfaces of the panel.

(1) **INSIDE SURFACES OF PANEL.** Remove any dirt, deadener, etc. from the damaged area with mineral spirits or naphtha. Scuff the area around the hole with No. 120 sandpaper to give a good bonding surface, then clean with mineral spirits or naphtha.

(2) **OUTSIDE SURFACE OF PANEL.** Working from the outside surface, file or grind the edge of the hole until the surface edge of the hole is slightly tapered toward the outer surface.

d. Base Patch Application—Inside Surface

Cut two pieces of Fiberglas cloth large enough to overlap all sides of the hole at least two inches, and prepare mixture No. 1 (resin).

NOTE: Do not use excess hardener as a soft repair will result.

Lightly wet the inside surface around the hole with this mixture, and apply two thicknesses of fiberglas cloth over the area so that the overlap around the hole is at least two inches.

Thoroughly wet the fiberglas cloth with the resin, then “squeegee” the excess resin from the fiberglas, but avoid getting the resin on the exterior surface of the roof top or panel. Make sure the fiberglas is stretched taut to eliminate excessive sag. Allow the patch to harden under heat.

NOTE: Cure of the patch may be hastened by use of an infra-red lamp. Do not heat in excess of 180°F.

e. Filler Patch Application—Outside Surface.

After the base patch has hardened, turn the panel over and remove all loose material around the hole on the outside surface of the panel. Sand the area with No. 120

sand paper until the paint is removed for a distance of approximately 2-3 inches from the edges of the hole, then clean with mineral spirits or naphtha.

Prepare mixture No. 2 (glazing putty).

NOTE: *Stir thoroughly and do not add excess hardener or a soft patch will result.*

From the outer surface, apply the glazing putty to the center of the hole with a putty knife and work toward the edge of the hole. Build the material up above the level of the panel contour, and make certain that all air pockets are removed.

Bake the entire panel 30 minutes at 180°F. in an oven or use an infra-red lamp at 11-12 inches from the patched area until the material hardens.

NOTE: *Do not heat above 180°F. or the plastic panel may sag.*

After cooling to room temperature, file or grind the outside patched area to the proper contour, then sand the area with No. 180 or No. 220 sandpaper.

Blow the loose material from the area, then wipe it thoroughly with a clean tack rag. If the repair area is merely a pit or minor damage that has not fractured the roof material, it will not be necessary to apply the cloth patch to the inner surface of the panel. In such a case, grind, sand, and clean the area as previously outlined. Fill any pin holes or shallow spots with the resin mixture (No. 2), and bake the reglazed area for only 15 minutes at 180°F.

f. Refinish After Repair.

Dry scuff the entire panel with No. 360 silicon carbide paper. Wipe clean with mineral spirits or naphtha, then wipe the area with a tack rag.

Spot spray a color coat over the repaired area, allow to dry for 3-5 minutes, then spray a cover coat of the desired color over the entire panel.

Bake the entire panel for 30 minutes at 180°F., in an oven, or use an infra-red lamp. Do not heat above 180°F.

5. GENERAL BODY MAINTENANCE

The general maintenance procedures covered in this section are comparatively simple means of avoiding more serious body trouble in the future. In eliminating rattles, the service man can discover and remedy minor adjustment troubles which, if neglected, could lead to major misalignment. Cleaning and care of the exterior surfaces, chrome parts, and fabrics will prevent deterioration and preserve the appearance of these parts.

The following methods should be used in performing this important but often neglected phase of automobile servicing:

a. Eliminating Rattles.

Most rattles are caused by a loose bolt or screw. Foreign objects such as nuts, bolts, or small pieces of body deadener in the door wells, pillars, and quarter panels are often the source of rattles. Door wells can be checked by carefully striking the underside of the door with a rubber mallet. The impact made by the mallet will indicate if loose objects are in the door well.

All bolts and screws should be tightened immediately after the first 1000 miles of vehicle operation. Regular body bolt inspection and tightening should be performed during all the years of usage. In the event tightening the bolts and screws, located on such assemblies as the doors, hood, and deck lid, does not eliminate the rattles,

the trouble is probably caused by misalignment. If this is the case, follow the adjustment and alignment procedures for these assemblies.

Rattles and squeaks are sometimes caused by weather stripping and anti-squeak material that has slipped out of position. Apply additional cement, or other adhesive, and install the material in the proper location to eliminate this difficulty.

b. Exterior Cleaning.

The outside finish should be frequently washed. Never wipe the painted surfaces with a cloth. Dusting the finish when it is dry tends to rub the dust and dirt into the baked enamel, and leaves a sandpaper effect on the surface. To keep the finish bright and attractive, and eliminate the necessity of using polish, wash the vehicle whenever it has accumulated an excessive amount of dirt and road salt. If the finish does become dull and unattractive, it may be restored to its original brilliancy by applying Ford cleaners and/or polishes.

c. Care of Chrome Plated Parts.

The chrome plated parts of the car deserve special care. Extra precautions and periodic cleaning will preserve the beauty and life of these finishes. Wash only with mild soaps or detergents. Using a clean soft cloth

or a sponge and water, rinse and wipe the parts dry. Chrome cleaning compounds may be used sparingly for the removal of rust. Do not scour finish parts with steel wool or polish them with products containing abrasives. FoMoCo Chrome Protector will provide excellent protection for all bright metal parts.

d. Care of Convertible Top Fabric.

Proper care of the top material will reduce the possibility of water stains, mildew, or shrinkage. Do not fold the top if it is damp or soaked. Always use the Convertible top boot to keep the top material clean and dry when the top is in the fully lowered position.

Use the top compartment behind the rear seat back only for storage of the top. The storage of other items such as a car jack, golf clubs, luggage, or other miscellaneous objects, not only interferes with the proper operation of the top, but may also damage or stain the top material.

Top material that has become faded should be treated with a top dye (except plastic coated material). Top dye not only restores the original color of the top, but it also preserves the material and acts as a sealer.

(1) **WASHING TOP FABRIC.** The top material should be cleaned and washed at least twice every three months to prevent fine particles of dust and grit from becoming imbedded in the fabric. Removal of such dirt particles would require hard scrubbing and a stronger soap solution which could damage the surface of the fabric.

Before washing the fabric, remove all loose dirt with a brush or a small portable vacuum cleaner.

Mix one part of Foam Cleaner with two parts of water. Cover the bottom of a suitable container with diluted foam cleaner. Soak up the liquid with a clean sea-wool sponge (about the size of a fist). Add more liquid if necessary to completely saturate the sponge. Alternately squeeze and release the sponge until all the liquid has been transformed into foam.

Apply foam to the fabric with the sponge or a soft brush. Rub in a circular motion and finally in the direction of the nap of the material. Never saturate the fabric with liquid. Occasionally, dip the dirty sponge in a separate pan of clean water and squeeze it dry before applying more foam.

Thoroughly clean the sponge (or use a second sponge), then squeeze the water out of the sponge. Wipe off all emulsified dirt and excess foam from the top surface.

Remove excess moisture from the cleaned fabric with an absorbent cloth, allow the fabric to dry, then brush it.

(2) **APPLICATION OF TOP DYE.** Top dye is available in black (8A-19510-A), in tan (8A-19510-B), and in green (8A-19510-C).

Before applying top dye, clean the loose dirt and film from the fabric with a brush or a vacuum cleaner. Wash the fabric lightly with Foam Cleaner (8A-19526-A). Allow the top to dry thoroughly. Top dye may be applied with a good paint brush; however, a spray gun is recommended.

If using a brush, stir the dye thoroughly, and if necessary, thin the dye with enamel or lacquer thinner before brushing. For spraying, reduce the viscosity by adding one part enamel or lacquer thinner to two parts top dye.

The body should be covered before spraying. Apply top dye in the same manner as applying paint to the body. One coat of top dye is usually sufficient. However, an additional coat may be added if the top is badly faded. If an additional coat is to be added, allow the top to dry for 15 to 20 minutes between coats.

Keep the car in direct sunlight, or in a warm dry place, for at least 12 hours after applying top dye. Do not fold the top for at least two days.

If, through improper masking, some top dye falls on the body, it should be wiped off immediately with a cloth soaked in turpentine.

CAUTION: Do not use top dye near an open flame.

(3) **PLASTIC COATED TOP.** If the plastic coated top is not too badly soiled, clean the material with mild soap and lukewarm water. If the top becomes badly soiled, use FoMoCo Foam Cleaner (8A-19526-A). Use a mixture of one part cleaner to two parts water on badly soiled areas. The mixture may be varied depending on the soiled condition of the material. Use a soft brush with the mixture. If Foam Cleaner will not remove spots, use a household abrasive cleaner.

CAUTION: The plastic coating used in this material becomes tacky at approximately 180 degrees. When making paint repairs, be sure to protect the material from heat and paint thinners.

e. Interior Cleaning.

Foam Cleaner (8A-19526-A) can be applied to any of the various materials used in the body interior. This cleaner is a concentrated solution and should be diluted with water in either one of two different mixtures according to the material application. Mixture No. 1 consists of five parts water to one part cleaner; mixture No. 2 calls for two parts water to one part cleaner. Shake the container well, add cleaner to water as required, and work the mixture into a rich foam with a sponge.

The proper mixture and cleaning procedure for each material is given in the following paragraphs.

(1) **FABRIC UPHOLSTERY.** Apply mixture No. 1 freely with a soft bristle brush. Use short light strokes

until the foam disappears. Wipe off the emulsified dirt with a turkish towel, and allow the material to dry. When dry, brush the material in the direction of the nap.

(2) **LEATHER, PLASTIC, AND IMITATION LEATHER.** Apply mixture No. 2 lightly with a brush, and leave it on the material for two or three minutes. Make a second application and brush well. Remove the residue with a clean soft cloth.

(3) **SEAT COVERS.** Do not remove the covers from the seats. Freely apply mixture No. 2 with a brush to the entire seat or back rest. Repeat the application and wipe it off at once with a clean, soft cloth. Dry as soon as possible by direct sunlight or heat lamp.

(4) **CARPET AND FLOOR MATS.** Sweep or vacuum the carpet thoroughly. Freely apply mixture No. 2

with a brush until the foam disappears. Wipe with a damp sponge in the direction of the nap. When cleaning rubber mats, first apply the mixture freely with a brush, and, if a second application is needed, scrub with a cloth or turkish towel.

(5) **HEADLINING.** Apply mixture No. 1 with a natural sponge. Use a light circular motion until the foam disappears. Clean one panel at a time and overlap on the next panel. Squeeze the solution from the sponge before cleaning the next panel. Lay the nap down and allow it to dry. When completely dry, brush the material with a dry soft brush. Brush from right to left with light strokes. Mixture No. 2 can also be used to remove bugs from the exterior car finish and to clean black or white side wall tires.

6. PAINT REFINISHING

In order to simplify the handling of paint problems, a description of abnormal paint conditions is given in the first paragraph of this section. Any of these conditions can be corrected by one of the three repair procedures given in the succeeding paragraph.

a. Paint Problems.

This paragraph lists the abnormal paint conditions that are encountered most frequently. It is very important to identify the paint condition correctly so that the proper repair procedure may be followed. Reference is made to the recommended repair procedure for each of the conditions described.

(1) **SCRATCHES.** Scratches are thin marks or tears that may partially or completely penetrate the surface of the finish coat of paint (fig. 18).

Correction of scratches is dependent on their depth. A scratch of very light penetration can usually be removed by application of a rubbing compound. Where the penetration is very deep, remove the paint from the surrounding area and refinish. *Use repair procedure (2).*

(2) **CHIPPING AND STONE BRUISES.** Chipping is where the surface of the finish coat of paint has been

broken by a sharp blow, and small particles of paint have flaked off (fig. 19). Frequently, stone bruises result in chipping (fig. 20). *Use repair procedure (2).*

(3) **PEELING.** This is a condition where large areas of the enamel or primer coat separate from the metal or prime coat (fig. 21). Do not confuse this with "Orange Peel." When peeling is experienced, remove all the old paint from the area concerned. *Use repair procedure (1).*

(4) **DIRT IN PAINT.** This term describes dirt, soot, or other foreign material that is embedded in the surface of the paint film (fig. 22).

Patches, where dirt appears, should be sanded smooth and refinished. In most cases, removal of the dirt can be accomplished without having to sand down to the primer coat of paint. It is possible to confuse this condition with blistering. To verify the condition, prick the suspected areas, and note whether there is foreign material under the surface. *Use repair procedure (2).*

(5) **PITS AND CRATERS.** This may be identified by the appearance of small round depressions in the paint (fig. 23 and 24).

Remove old finish and repaint. *Use repair procedure (2).*

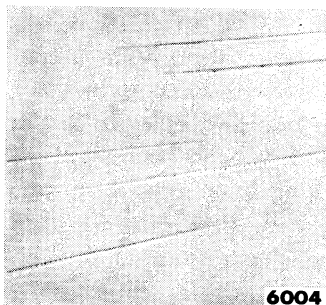

Fig. 18—Scratches

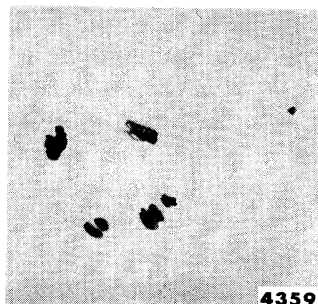

Fig. 19—Chipped

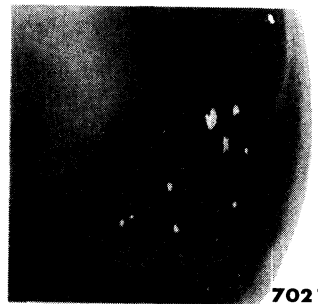

Fig. 20—Bruises



Fig. 21—Peeling

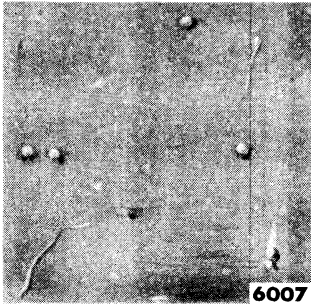

Fig. 22—Dirt in Paint

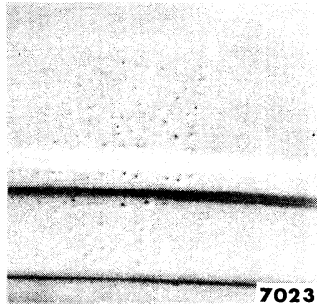

Fig. 23—Pits

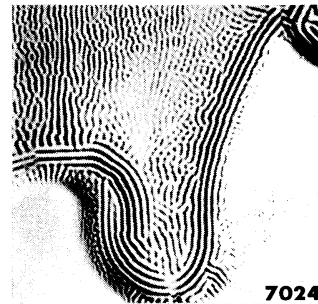

Fig. 26—Wrinkles



Fig. 27—Overspray

NOTE: This condition may arise from failure to remove silicone polishes before repainting.

(6) **RUNS, SAGS, AND WRINKLES.** This is evidenced by uneven collections of paint on the finished surface (fig. 25). The collections may appear in the form of tear drops or sagging lines. Usually these lines are quite soft and sometimes they may be wrinkled (fig. 26). Where this occurs, smooth out uneven surfaces and refinish. *Use repair procedure (2).*

(7) **OVERSPRAY.** This is evidenced by a rough, dull finish of the area surrounding the paint repair (fig. 27). Lightly sand out the spray dust and apply a properly thinned out finish coat, or *use repair procedure (3).*

(8) **ORANGE PEEL.** Orange peel is a term used to describe an uneven, mottled appearance on the paint surface (fig. 28).

Smooth out with sandpaper. Spray with two finish coats of paint. *Use repair procedure (2).*

(9) **OFF COLOR.** This term is applied to adjacent areas on which the colors do not match (fig. 29). It may also appear when making spot repairs. *Use repair procedure (2).*

(10) **PRIMER SHOWS.** This condition exists when the primer shows through the finish coat of paint (fig. 30).

When this condition is experienced, clean the surface, and spray two finish coats of paint over the affected area. *Use repair procedure (2).*

(11) **CHALKING.** Chalking is evidenced by the formation of a white or gray film on the paint surface (fig. 31). *Use repair procedure (3).*

(12) **BRONZING.** Bronzing is a type of film cast over the original paint, reflecting in a bronze effect (fig. 32). *Use repair procedure (3).*

(13) **CRACKING.** This is evidenced by the paint curling up in areas. Frequently this starts at the edge of a panel (fig. 33). *Use repair procedure (1).*

(14) **CHECKING.** "Line checking" has the appearance of thin, straight lines criss-crossing each other (fig. 34). These lines may be from one-half inch to four inches, or longer, increasing in length as the finish ages.

"Crow Footing" is small lines branching off from a point in all directions, giving the appearance of crows feet (fig. 35). *Use repair procedure (1) or (2).*

(15) **BLISTERING.** Blistering is the formation of bubbles or pin points on the surface of the finished work (fig. 36 and 37). Unless inspected by a magnifying glass, this condition is very hard to identify. In some instances, this complaint may be confused with dirt in the paint. To verify this condition, prick the suspected areas, and note whether a hole exists under the bubble.

The only remedy is to completely strip off the paint down to the phosphate coat or bare metal, and repaint. While it may not be necessary to repaint the entire vehicle, do not attempt to remove the old paint from only a small portion of a panel, door, hood, fender, or top. The blisters may appear again on that portion which was not repainted. *Use repair procedure (1).*

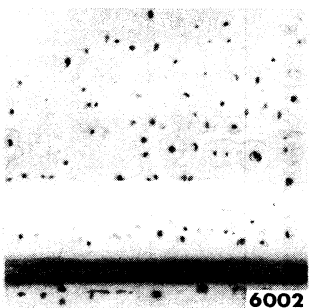

Fig. 24—Craters

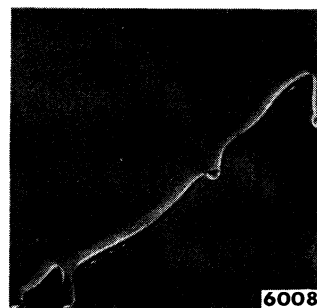

Fig. 25—Runs and Sags

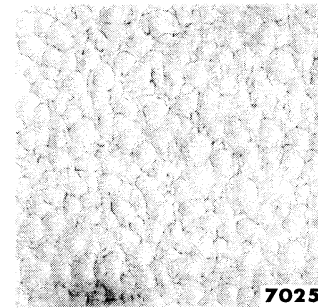

Fig. 28—Orange Peel

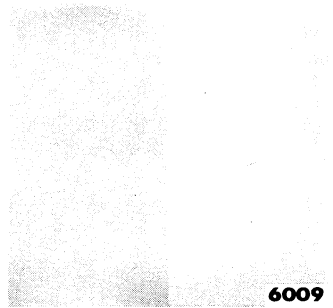

Fig. 29—Off Color

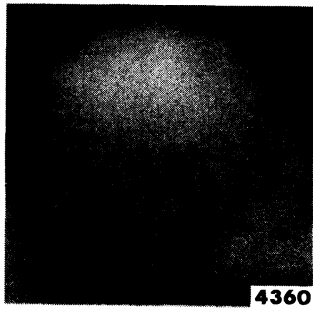

Fig. 30—Primer Shows



Fig. 31—Chalking

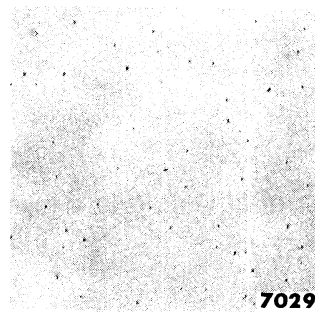

Fig. 36—Random Blisters

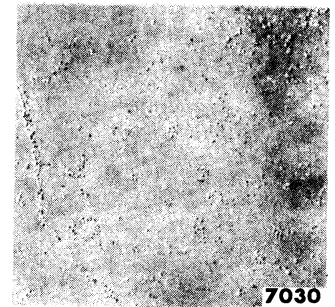

Fig. 37—Pattern Blisters

(16) **WATER SPOTTING.** This is evidenced by a milky pattern where water drops have fallen (fig. 38). Use repair procedure (3), and if this does not correct the condition, use procedure (2).

(17) **MILDEW.** Mildew growth is most commonly found in a very dark gray or black color, and occurs along radial lines (fig. 39). Use repair procedure (3), and if this does not correct the condition, use procedure (2).

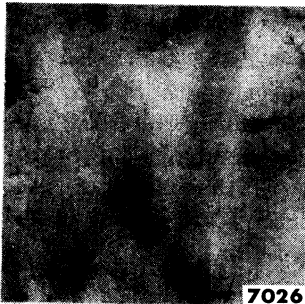

Fig. 32—Bronzing

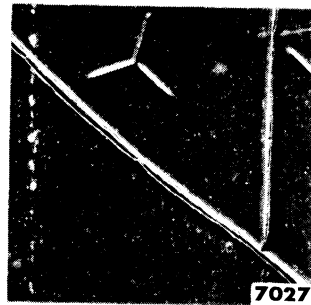

Fig. 33—Cracking

(18) **COLOR CHANGE.** This may be identified by one panel changing color more quickly than another panel and is usually due to repainting of individual panels in repair. Use repair procedure (2).

(19) **SPOT DISCOLORATION.** This is evidenced by brown spots or stains on the surface. Stains or spots can be caused by road tar, acid, or alkali bearing water from the streets. Use repair procedure (3) and if this does not correct the condition, use procedure (2).

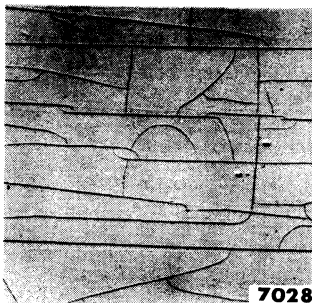

Fig. 34—Checking—Line

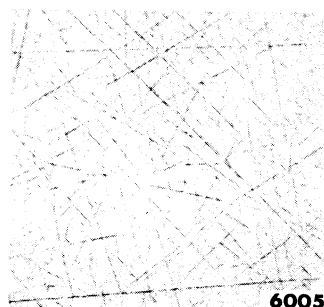

Fig. 35—Checking—Crow Footing



Fig. 38—Water Spotting



Fig. 39—Mildew

b. Paint Repair Procedures.

One of the following procedures should be followed as indicated, when repairing any of the paint conditions previously described.

(1) **REFINISHING COMPLETE CAR OR PANEL.** If the complete car is to be painted, remove the windshield wiper arms, then cover the front and rear bumpers, all exterior mouldings, all plastic ornaments, windshield wiper brackets, weather strips, etc. with masking tape. Acetate-fibre, clear tape is recommended where liquid paint strippers are used.

(a) **REMOVE PAINT.** Remove all damaged paint from the exterior surfaces of the body by sand blasting, shot blasting, disc grinder, or liquid stripper. If liquid stripper is used, carefully follow the supplier's instructions.

After the paint has been removed, wash off any accumulation of surplus material.

NOTE: If the paint was removed with liquid stripper, carefully follow the supplier's instructions for neutralization of excess material.

(b) **PREPARE METAL.** Apply metal conditioner to all areas from which the paint was removed. Avoid using an excessive amount, and carefully follow the supplier's instructions. Before applying the paint, remove all remaining traces of metal conditioner according to the supplier's instructions. It cannot be emphasized too strongly that the metal must be properly prepared before prime and color coats are applied.

(c) **APPLY PRIMER SURFACER.** Remove any dust from the surfaces with clean tack rags.

NOTE: Do not touch the metal with bare hands until finishing operations are complete.

Spot-glaze any bad metal with a suitable glazing putty. Wipe the area with a tack rag, then spray two coats of sanding type primer in accordance with the suppliers recommendations.

After the primer has dried as specified, lightly scuff-sand the primer to remove dirt and overspray.

Spray a final, wet, double coat of synthetic primer surfacer and allow to dry according to the suppliers' recommendations.

(d) **APPLY FINISH COAT.** Water-sand the surface with No. 360 sand paper. Use care to avoid cutting through to the bare metal. Rinse well, blow off all water from seams, cracks, etc., and dry thoroughly.

Wipe the work with a tack rag, and spray on two, full, finishing coats of paint. Follow the suppliers' instructions carefully.

The car is now ready for whatever drying process is available.

Remove the masking tape, and water-sand the edges of the doors, along the weatherstrips, etc. Carefully touch up any portions missed by the spray.

When the job is entirely dry, install the hardware, etc.

(2) **SPOT REPAIRING.** The end result of spot repairing depends upon the skill and knowledge of the operator doing the repair. In most cases, a more satisfactory repair may be obtained by finishing the complete panel involved.

(a) **REMOVE PAINT.** Before sanding the surfaces to be painted, remove all traces of wax, polish and grease with a good wax and grease remover. Dry the panel with a clean cloth. If the car has been polished with a wax or polish containing silicone, remove the silicone base as instructed under "c. Removal of Silicone Polishes for Repaint."

Feather-edge broken spots with coarse sand paper. Treat any rusty metal with a metal conditioner. Follow the suppliers' instructions for removal of any remaining traces of conditioner.

(b) **APPLY THE PRIMER SURFACER.** Spot-spray bare and feathered edges with primer surfacer, reduced according to the suppliers' recommendations. Permit each coat to become dull (after all thinner has dried off) before applying additional coats. Allow the final coat to dry the length of time specified by the supplier, before sanding. Sand the primer surfacer according to recommendations. If any imperfections still show, smooth out with spot glazing putty. Allow the putty to dry the length of time specified, and sand the same as primer surfacer.

Rub around the patches with rubbing compound to remove scratches in the old finish and overspray. Wipe clean with a cloth dampened with enamel thinner.

Spray the area to be painted with one medium coat of a sealer, reduced according to the suppliers' instructions. Allow to dry the length of time specified and, if necessary, scuff lightly with fine sand paper to remove nibs.

Wipe the area with a tack rag, and spray on two full finishing coats of paint according to the suppliers' recommendations.

Remove the masking tape, etc., and allow the paint to dry according to the suppliers' recommendations. Do not allow the work to become water spotted before it is entirely dry.

(c) **REMOVAL OF SILICONE POLISHES FOR REPAINT.** All traces of wax and polish containing silicone must be removed from the painted surfaces before refinishing. Any paint surface, suspected of having been treated with these substances, should be tested as follows: Spray enamel of any color on a small vertical area of the car that is to be refinished. If "fish eyes" or craters form on the surface of the sprayed area, silicone polish has been used.

The following procedure for removing silicone polishes from painted surfaces is recommended:

Wash off the area to be painted with clean rags saturated with a known brand of silicone remover or good enamel thinner. Before the solution has a chance to dry, wipe off with **CLEAN**, dry rags. Change the rags frequently. Do not re-use these rags any where in the shop, but dispose of them immediately. If the silicone residue from the rags gets on any refinished surface, "fish eyes" will result when the area is painted.

Wet-sand the area with No. 320 sand paper then wash with water and dry off.

Saturate clean rags with a silicone remover or a good enamel thinner, wipe off the entire sanded area with the saturated rags, and then wash off the area.

Change to dry, clean rags and remove any excess solution. Be sure that all accumulated polish is removed from crevices of drip rails, doors, mouldings, etc.

NOTE: The importance of keeping the paint shop clean and free from the silicone materials on rags, clothing, or spray equipment cannot be over emphasized. Do not use a spray gun to spray refinishing materials after it has been used to apply silicone polishes. Make sure that refinishing work is not done near an area where silicone or wax polishes are applied.

(3) **POLISHING.** In cases where the paint condition calls for repair procedure No. (3), apply FoMoCo polish (8A-19530-A) to the affected area as directed on the container.

Part FOUR

BODIES

Chapter

II

Trim, Upholstery, and Window Glass

Section	Page
1 Door and Quarter Trim Panels	289
2 Headlining Replacement	292
3 Ventilator and Division Bar	294
4 Door Glass and Regulator Replacement	296
5 Door Glass Adjustments	299
6 Quarter Glass	303
7 Windshield and Rear Window	307

The service operations in this chapter apply to all models unless otherwise stated in the text. Headlining replacement as well as all necessary glass and regulator adjustment and replacement procedures are given here. Since door and quarter glass or regulator service operations require the removal of the interior trim, the procedures for removing trim panels are also given in this chapter.

When service operations are performed inside the car,

special attention should be given to cleanliness. Place a cover over the seats and other inside surfaces to protect them from contact with dirty hands, tools, or clothing. When removing body hardware, be sure to insert the screwdriver firmly in the slots of the screws. Observance of these precautions will prevent unsightly scratches and unnecessary cleaning after the work is finished.

1. DOOR AND QUARTER TRIM PANELS

Before any door or quarter trim panel can be removed, the inside door handle and window regulator handle must be removed. The door and window regulator handle replacement procedures apply to all models.

Trim panels are attached to the door and quarter panels by screws and trim clips. The number of clips used depends upon the type of trim panel (door or quarter) and the particular model. If any trim clip tends to fall out of its recess in the trim panel, replace it.

Many of the accompanying trim panel parts, such as arm rests and garnish mouldings, have screws of two or three different sizes. When removing such a part, note the length of the screws so that they can be installed in their original location.

a. Window Regulator Handle and Inside Door Handle.

The window regulator handle and inside door handle are held in place with horseshoe type retainers. Insert the tool shown in fig. 1 between the flange of the handle

and the friction plate. Turn the tool until it engages the retainer, pull the retainer off the shaft, then slide the handle off the shaft.

To install, raise the door glass to the closed position. Position the friction plate to the trim panel, then install the horseshoe type retainer in the regulator handle. Use a new retainer, if the old one is bent. Install the retainer with the open ends toward the handle; otherwise the retainer will be difficult to remove when future repairs are made. The retainer can be installed by hand, or the

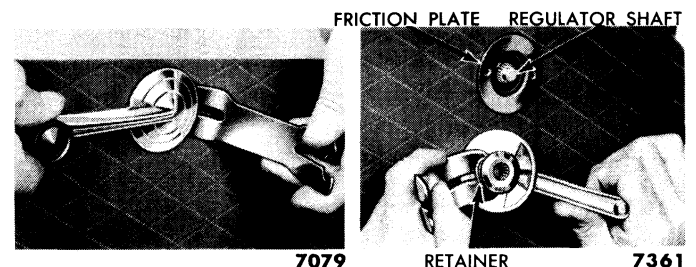

Fig. 1—Window Regulator Handle Removal

Fig. 2—Window Regulator Handle Installation

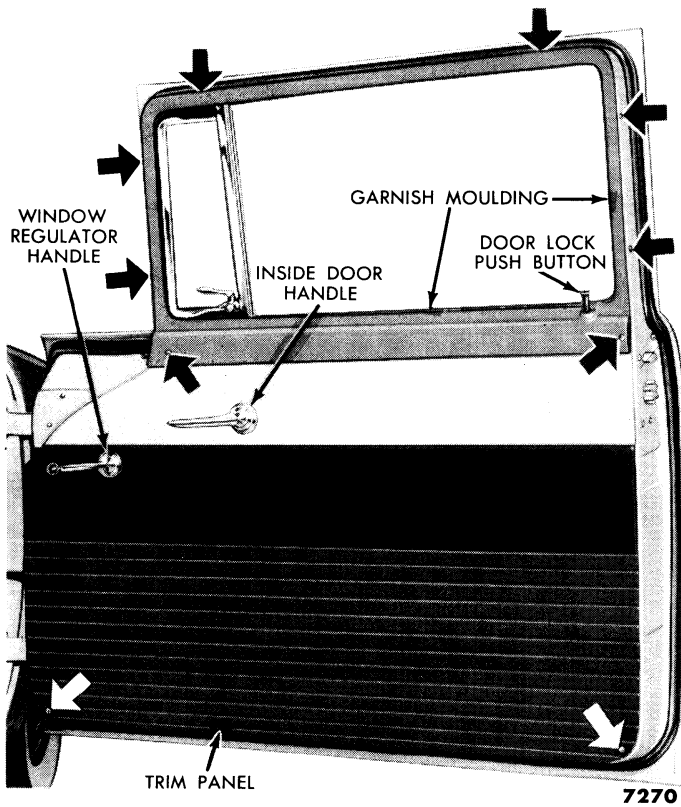

Fig. 3—Door Interior Trim—Front Door Shown

tool shown in fig. 2 can be used to facilitate installation. Position the handle on the regulator shaft so that the handle is one serration below horizontal and pointing toward the hinge side of the door. Push the handle in until the retainer engages the groove in the shaft. Install the door handle in the same manner (fig. 3).

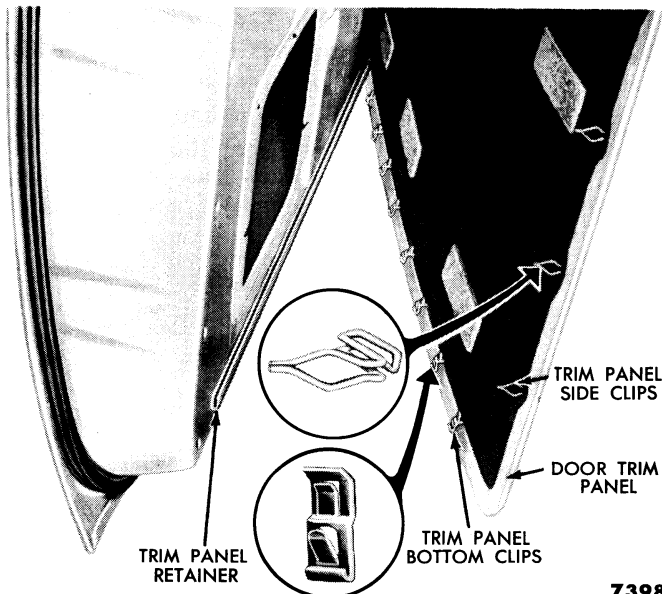

Fig. 4—Door Trim Panel Removal

b. Door Trim Panel and Garnish Moulding Replacement.

The following removal and installation procedures apply to both the front and rear door.

(1) **REMOVAL.** Remove the inside door handle and the window regulator handle. Remove the two retaining screws and the arm rest (if so equipped). Remove the screws at the lower corners of the trim panel and the garnish moulding retaining screws (fig. 3). Unscrew the push button from the door lock control rod, and remove the garnish moulding.

Release the trim clips along the front and rear edges of the trim panel (fig. 4). Carefully pry the clips free with a screwdriver. Hold the screwdriver as close to the clips as possible to prevent tearing the trim panel or damaging the paint. Raise the trim panel until the bottom clips are released from the retainer (fig. 4).

(2) **INSTALLATION.** Check the inner side of the trim panel to make sure that all padding is in place. Replace all damaged or missing trim clips. Lower the panel until the bottom clips enter the retainer. Center the trim panel on the door, and fasten the side clips. Install the retaining screw at each lower corner of the trim panel. Install the inside door handle and the window regulator handle.

To install the garnish moulding, position the garnish moulding on the door, then install the retaining screws (fig. 3). Draw the lip of the ventilator weatherstrip over the garnish moulding, and screw the push button on the door lock control rod (fig. 3).

c. Quarter Trim Panel Replacement.

Separate quarter trim panel procedures are given for each of the various body styles.

(1) **TUDOR.** If only the trim panel is to be removed, it is not necessary to remove the garnish moulding. Remove the arm rest and spacers, then remove the seat and seat back. Remove the window regulator handle as shown in fig. 1. Release the quarter panel clips along the pillar and at the rear (fig. 5). Bend the lower retainers down and remove the two lower garnish moulding screws. Bow the trim panel slightly and slide it out from under the garnish moulding.

To install, bow the trim panel slightly and slide it under the garnish moulding. Bend the lower retainers up against the panel (fig. 5), align the forward edge of the trim panel with the pillar, and secure the clips. Secure the clip at the upper rear corner and install the window regulator handle. Install the two lower garnish moulding screws. Install the seat back, arm rest and spacers, and seat.

To remove the garnish moulding, remove the garnish moulding screws (fig. 5). Pull the garnish moulding out at the top, then raise it off the quarter panel flange.

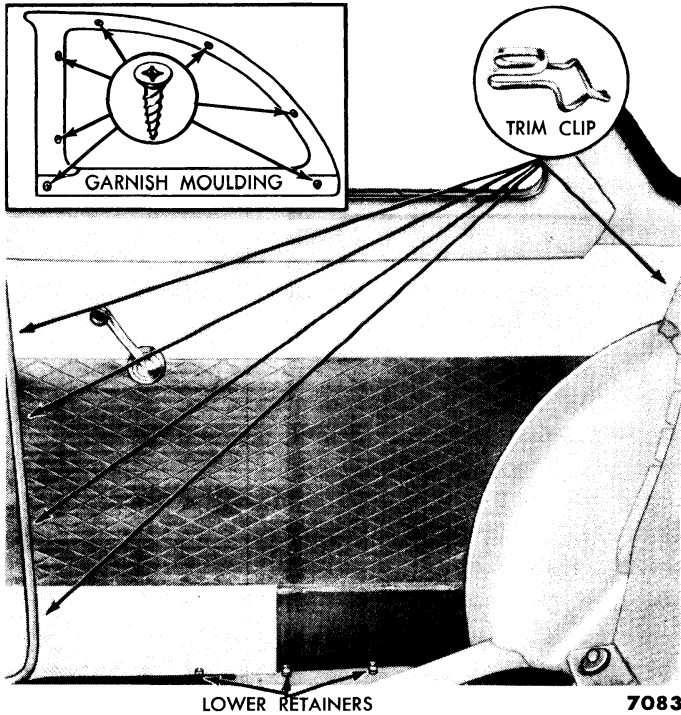

Fig. 5—Tudor Quarter Trim Panel

To install, position the garnish moulding over the flange of the quarter panel, then press the garnish moulding in at the top. Align the holes, and install the garnish moulding screws (fig. 5).

(2) **CONVERTIBLE.** The quarter trim on the convertible consists of the forward trim panel, the rear trim piece, and the arm rest assembly (fig. 6). These units

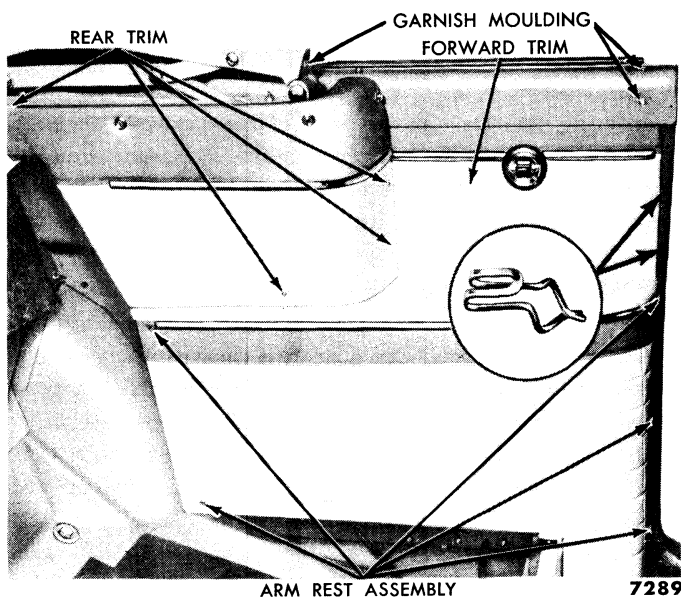

Fig. 6—Convertible Quarter Trim

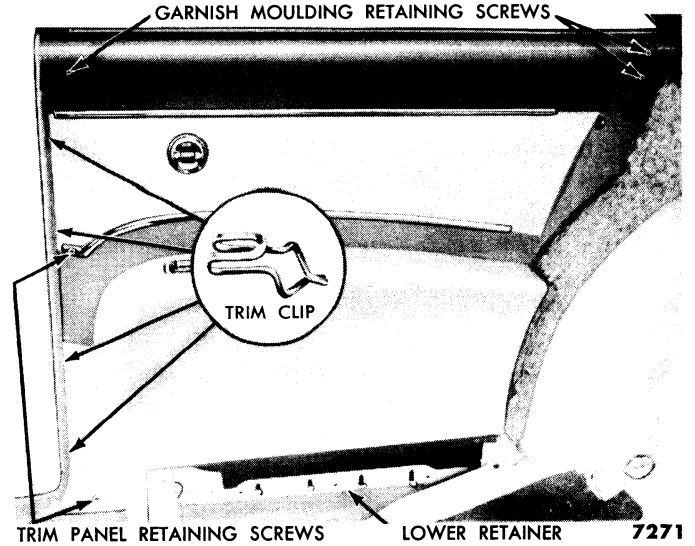

Fig. 7—Victoria Quarter Trim Panel and Arm Rest Assembly

are serviced as separate assemblies. The rear trim piece can be removed independently of the other two units after removing the seat and seat back. This permits adjusting the top mechanism without removing the complete quarter trim panel. The arm rest assembly cannot be removed without first removing the rear trim piece. In order to remove the forward trim panel, it is unnecessary to remove either of the other two trim units or the seat and back, but the two screws on the forward edge of the arm rest assembly must be loosened.

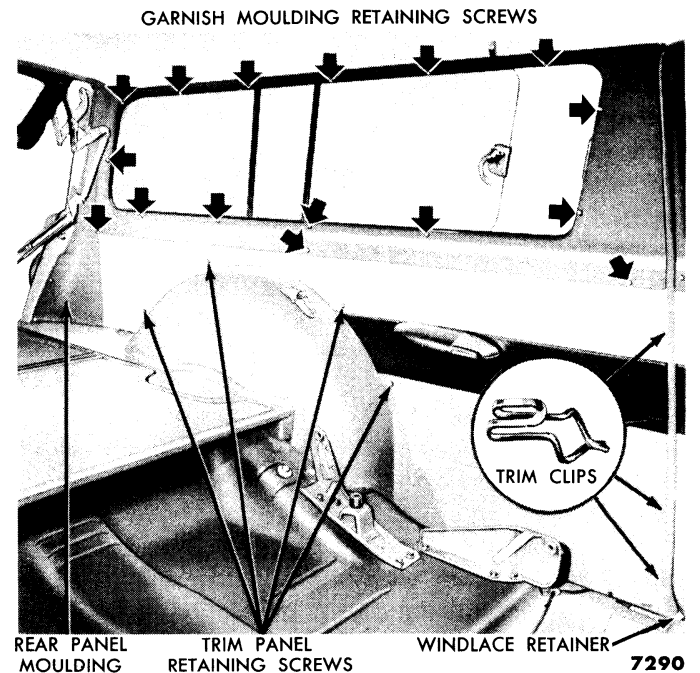

Fig. 8—Station Wagon Quarter Trim

To remove the rear trim piece, remove the four attaching screws, indicated by the heavy arrows in fig. 6, and lift the trim from the car. To install, position the assembly and install the four attaching screws.

To remove the arm rest assembly, remove the rear trim piece. Remove the four attaching screws as shown, and lift out the arm rest.

Before removing the forward trim panel, loosen the two attaching screws at the front edge of the arm rest assembly in order to allow clearance for removing the panel. Remove the window regulator handle. Remove the three garnish moulding screws and the moulding (fig. 6). Disengage the two trim clips at the forward edge of the panel, and remove the panel.

To install the forward trim panel, slide the lower edge of the panel behind the arm rest assembly and the rear edge of the panel behind the rear trim assembly. Fasten the forward edge of the panel with the two trim clips, then tighten the two arm rest assembly attaching screws. Install the garnish moulding and regulator handle.

(3) **VICTORIA.** Remove the rear seat cushion, remove two retaining screws at the lower edge of the seat back, and remove the seat back (fig. 7).

Remove the garnish moulding retaining screws and the garnish moulding. Remove the two retaining screws at the forward edge of the trim panel. Unfasten the four

trim clips along the forward edge of the panel, then remove the trim panel and arm rest as one assembly.

Position the trim panel and arm rest assembly in back of the lower retainer, fasten the forward edge of the trim panel to the quarter panel with four trim clips, and install the two retaining screws at the forward edge of the panel (fig. 7). Install the garnish moulding over the top edge of the trim panel, then secure the moulding in place with the two retaining screws at the rear and one at the front. Install the seat back and seat.

(4) **STATION WAGON.** Remove the garnish moulding retaining screws, then remove the garnish moulding (fig. 8). Remove the six retaining screws from the lower rear panel moulding, then remove the moulding. Remove the four trim panel retaining screws. Unfasten the four trim clips at the forward edge of the trim panel, disengage the windlace from the retainer, and remove the quarter trim panel.

To install, place the trim panel in position, engage the windlace in the retainer, and fasten the four trim clips at the forward edge of the panel (fig. 8). Install the four trim panel retaining screws. Install the lower rear panel moulding and secure it in place with six retaining screws. Install the garnish moulding and secure it in place with the retaining screws.

2. HEADLINING REPLACEMENT

The following headlining removal and installation procedures apply basically to all models. Figure 9 shows a typical view of headlining installation.

a. Removal.

Remove the sun visors and all inside finish strips. Remove the rear seat and seat back. Remove the rear window and package tray.

Pull the headlining loose where it is cemented around the rear window and windshield. On Tudor models, pull the headlining loose around the quarter windows. Insert a screwdriver between the windlace and headlining, and pry the headlining retaining strips away from the roof rail about $\frac{1}{4}$ inch. Headlining retaining strips are used only over the door openings. Unhook the headlining from the metal tabs on the retaining strips. Check to make sure the headlining has been loosened around all sides of the interior. Remove any drive nails that hold the headlining.

Start at the forward end, and pry the headlining support bows out of their retainers in the roof rails (fig. 10). Remove the headlining assembly and bows from the body. Due to the difference in the length of the headlining bows, each bow should be marked or tagged to assure proper location in the headlining. After marking the bows, remove them from the headlining.

b. Installation.

Before installing the headlining, check the headlining retaining strips to make sure they are tightened securely to the roof rail. Check the tabs on the retaining strips, and straighten any tabs that were bent during the removal of the headlining. Check the roof panel insulation to make certain it is properly cemented in place.

Insert each roof bow in its original listing in the headlining. Starting at the rear of the body, hook each end of the rear bow in its respective retaining hole at each roof rail. Install the rear headlining support retainers as shown in fig. 10. Assemble the remaining roof bows to their retainers in proper sequence, and space the headlining evenly between the bows as they are installed.

After installing the bows, secure the rear bow to the support retainer. Stretch the headlining toward the front to take up any slack in the material between the bows. Stretch the material along the sides to make sure it is properly centered. In some cases, it may be necessary to cut the ends of the headlining listings in order to stretch the material tight.

Fasten the headlining to the retaining flange along the windshield header (fig. 9). When pulling the headlining at the header, be sure the first seam is straight from

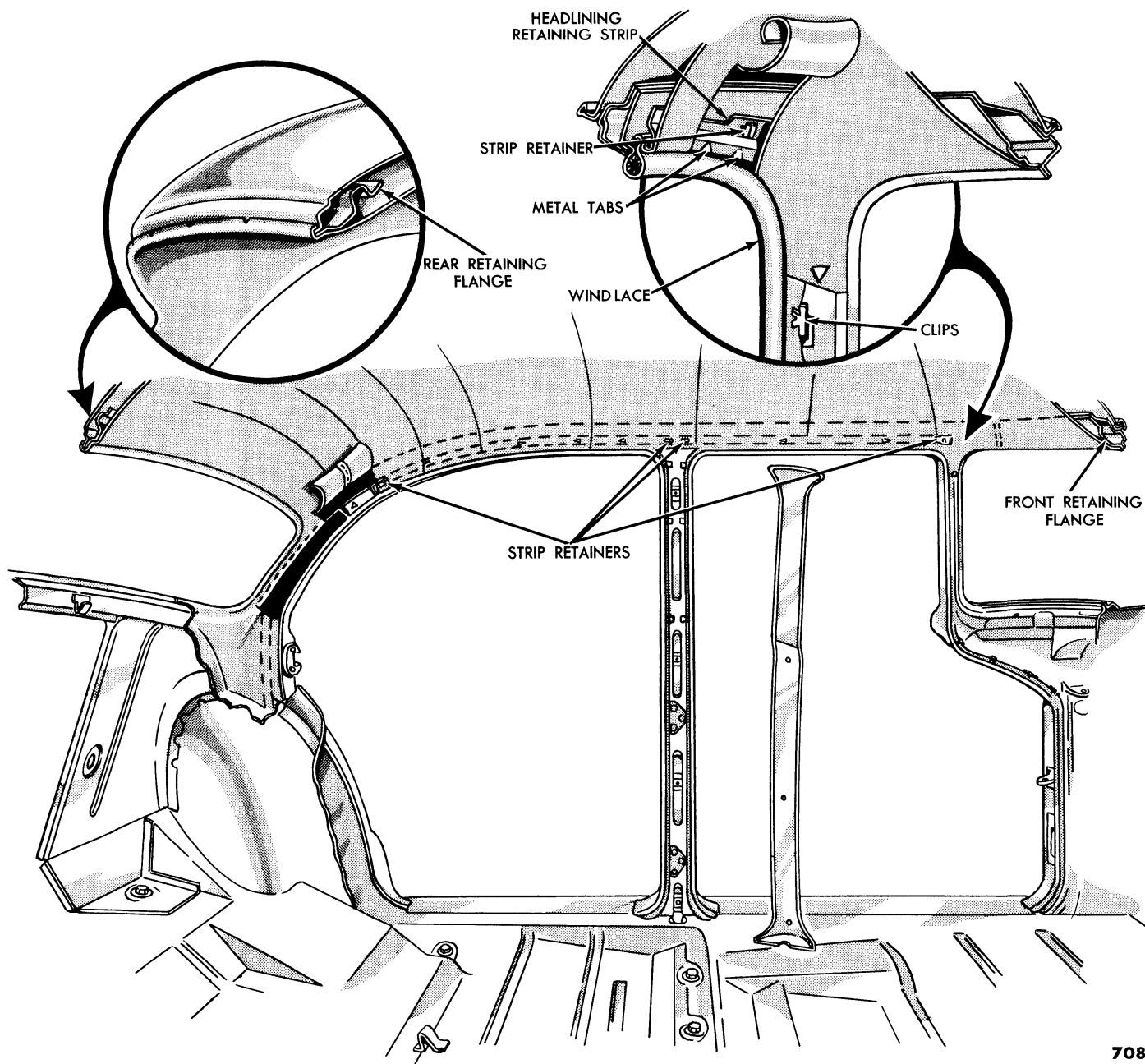

7086

Fig. 9—Typical View of Headlining Installation

side to side. Pull the rear section of the headlining down starting at the center, and fasten it to the rear retaining flange around the rear window (fig. 9). Work toward the ends until the headlining has been fastened across the rear section. Do not pull the headlining down too tightly or the contour will be lost at the rear corners. Make certain that the rear headlining seams are straight.

Cut off the excess material around the rear window and the windshield openings. When trimming the excess

material, make certain that loose ends do not extend over the windshield or the rear window retaining flanges.

When working on a Tudor, apply trim cement around the quarter window openings along the top and down to the lower rear corner. Trim the headlining around the quarter window opening so that only 1½ inches of material is allowed for overlap. Cut a series of radial slits in the material to avoid wrinkles. Draw the material just taut enough to remove all wrinkles. Press the

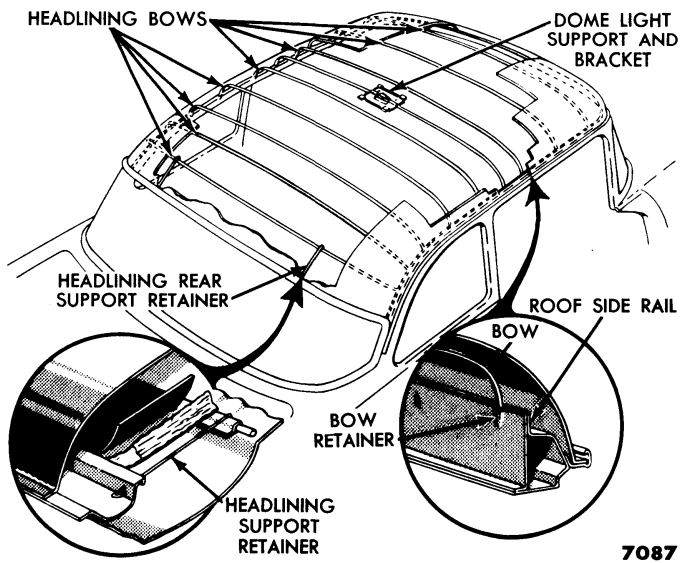

7087

Fig. 10—Typical View of Roof Bow Installation

3. VENTILATOR AND DIVISION BAR

This section outlines service procedures for three different ventilator assemblies, the front door ventilator for Tudor and Fordor models, the front door ventilator for Convertible and Victoria models, and the rear door ventilator used on Fordor and Station Wagon models.

Division bar adjustments directly affect window glass adjustment, because the division bar forms the forward glass run on front doors, and the rear glass run on rear doors. Therefore, such adjustments will not be included

material on the cemented surface.

Allow about one inch overlap, then trim off the excess material along the top of the door opening. Start at the forward bow and pull the headlining down to remove wrinkles at the seam. Push the headlining up under the headlining retainer with a dull putty knife. Repeat the same operation at the next bow. Remove all slack between the bows. Fold the forward corners of the headlining, then nail the corner to the windshield header. Install the interior finish strips.

Install the sun visors. To locate the holes for the visor mounting bracket under the headlining, use a straight pin. After locating the screw holes, make a $\frac{3}{4}$ -inch cut (large enough for the visor pivot) in the headlining between the screw holes. Position the visor in line with the holes, and install the screws. Install the rear window and garnish mouldings, package tray, seat, and back.

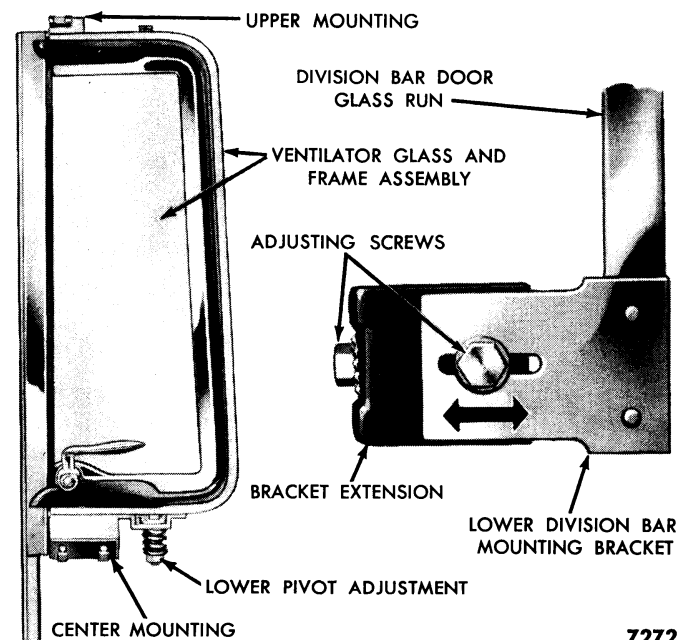

7272

Fig. 11—Front Ventilator and Division Bar

here, but will be given later as part of the door glass adjustment.

a. Front Door Vents.

On front doors, the vent window and division bar are fabricated in one assembly. The complete assembly is attached to the door at three points: the upper mounting; the center mounting; and at the lower end of the division bar (fig. 11). The vent glass is mounted to the assembly at the upper and lower pivots.

The lower pivot adjustment and glass replacement procedures apply to all front vent windows regardless of model. Procedures for replacement of the complete ventilator and division bar assembly differ according to model.

(1) **LOWER PIVOT ADJUSTMENTS.** The lower pivot adjustment controls the opening and closing of the window in its frame and has no effect on adjustment of the assembly as a whole.

The spring tension at the lower pivot (fig. 11) can be increased or decreased. If the ventilator operates too freely, tighten the lock nut to increase the spring tension. If the ventilator binds or is hard to operate, loosen the lock nut to decrease the spring tension. Apply Lubriplate to the pivot after making adjustments.

(2) **GLASS REPLACEMENT.** It is not necessary to remove the complete ventilator assembly when replacing only the glass.

Apply carbon tetrachloride to both sides of the glass

where it is mounted in the frame. Allow the carbon tetrachloride to soak into the glass retainer strip for several minutes, then pull the glass out of the frame. In difficult cases, it may be necessary to pry the upper and lower ends of the frame away from the glass.

Before installing the glass, thoroughly clean the glass channel. If the ends of the frame were pried apart, the frame should be straightened to its original shape.

Place a new glass retainer strip over the edge of the glass. Apply a thin film of liquid soap around the outside surface of the retainer strip, then insert the glass in the frame. Force the glass into the frame with a rubber mallet until it is flush with the upper and lower ends of the frame. Trim the excess retainer strip material from around the glass.

(3) **ASSEMBLY REPLACEMENT.** The mounting bracket and extension at the lower end of the division bar is the same for both type assemblies. Differences in other mounting points, however, necessitate separate procedures.

(a) **TUDOR AND FORDOR.** Remove the garnish moulding and door trim panel. Lower the door glass. Remove the upper mounting screw and the two center screws. Remove the lower bracket extension from the bracket and door panel. Swing the ventilator assembly inward at the top to allow sufficient clearance for the bracket at the lower end of the division bar. Lift the assembly out of the door.

Lubricate all pivot points with 8L-19586-A lubricant or its equivalent. Position the ventilator assembly in the door. Pull the lip of the weatherstrip over the door. Install the center and upper mounting screws. Assemble the bracket extension to the bracket and inner door panel. Make the necessary adjustments to assure a freely operating door glass, as outlined in section 5.

(b) **CONVERTIBLE AND VICTORIA.** Remove the garnish moulding and door trim panel. To remove the ventilator assembly from the convertible and Victoria, it is necessary to remove the door glass first. Remove the nuts from the shoulder bolts at points "A" and "B," and the screws at points "C," "D," "E," and "F" (fig. 12).

Remove the extension from the bracket at the lower end of the division bar. Swing the assembly in the inner panel to allow sufficient clearance for the bracket, and lift the assembly from the door.

To install, position the assembly in the door and attach the front leg of the casting to the door inner panel reinforcement at point "A" and to the door inner panel at point "B" (fig. 12). Install the nuts and washers on the shoulder bolts. Assemble the extension to the division bar bracket and install the retaining screws at "C," "D," "E," and "F" (fig. 12). Install the door glass. Adjust the division bar to the door glass as outlined in section 5.

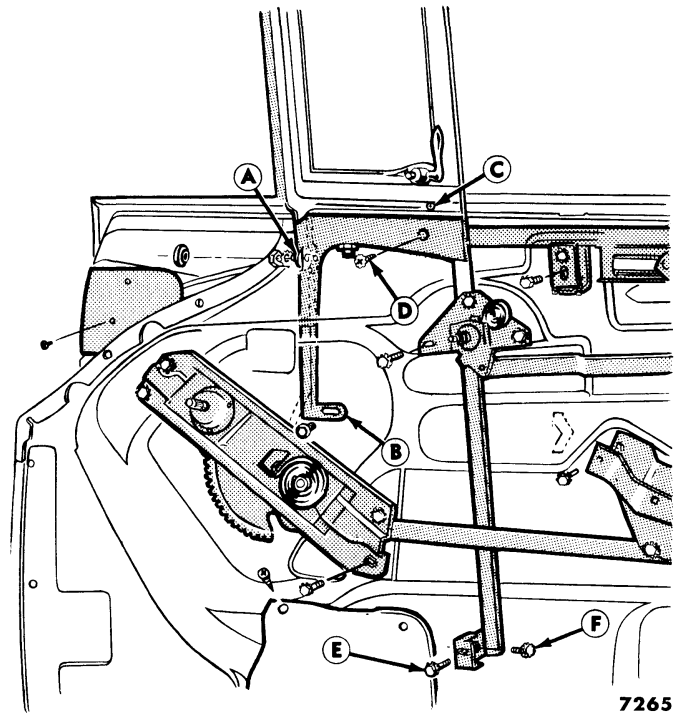

Fig. 12—Vent Assembly—Convertible and Victoria

b. Rear Door Vents.

On rear doors, the division bar is a separate assembly from the glass and weatherstrip, and the vent window cannot be opened and closed (fig. 13). The division bar is attached to the door by screws at the top, center and

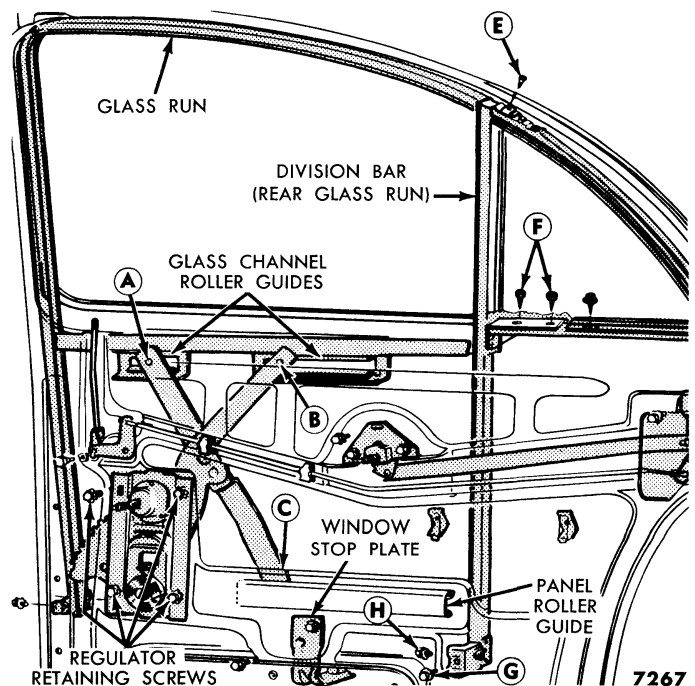

Fig. 13—Rear Window Mechanism—Fordor—Typical of Station Wagon

lower end. The stationary glass is framed in a rubber weatherstrip which is mounted in the door opening. A right angle plate and the lip of the weatherstrip holds the assembly in place. The glass can be replaced without removing the division bar, but the division bar cannot be replaced without removing the glass.

(1) **GLASS REPLACEMENT.** To remove the glass, first remove the interior garnish moulding, then remove the screws and plate that hold the assembly in place. Push the window and weatherstrip frame assembly inward at the rear to disengage the weatherstrip lip from the opening and division bar recess. Remove the assembly toward the rear of the car.

Remove the weatherstrip from the glass, and clean the old cement out of the glass channel part of the weatherstrip. Cement the weatherstrip on the new glass. Run a bead of M-5397-B sealer around the edge of the window opening on the inside surface of the door flange and into the recess on the division bar. Soap the front

edge of the weatherstrip and press it into the division bar recess. Push the vent glass and weatherstrip assembly into position in the door opening, and pull the outer lip of the weatherstrip over the door flange with a cord. Install the garnish moulding.

(2) **DIVISION BAR REPLACEMENT.** Lower the window glass, and remove the vent glass and weatherstrip assembly. Remove the upper and center division bar mounting screws (fig. 13). Remove the lower bracket extension from the bracket and door panel (figs. 13 and 11). Lift the division bar out of the panel.

To install, insert the division bar (lower bracket extension removed) into the door panel. Install the lower bracket extension to the bracket and attach loosely to the door inner panel (fig. 13). Install the center and upper mounting screws, adjust the bar to the window glass as outlined in section 5, then tighten the upper, center and lower bracket screws. Install the vent glass and weatherstrip assembly.

4. DOOR GLASS AND REGULATOR REPLACEMENT

Scissor type regulators are used on all door windows (figs. 13 and 14). The front door window regulator differs from the rear door in that a separate arm and plate assembly is used in connection with the regulator assembly on the front doors (fig. 14). The arm and plate assembly is operated through a connecting link which is fastened by a spring retainer to the regulator assembly (fig. 14).

On all doors, the regulator operates the glass through three rollers attached to pins at the ends of the regulator

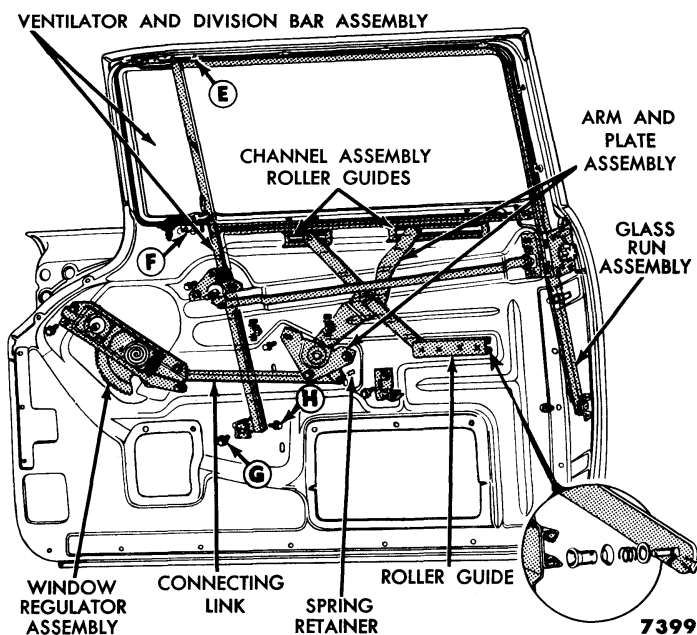

Fig. 14—Front Door Window Mechanism

arms (fig. 15). Two of these rollers ride in the glass channel; the other rides in a fixed guide welded to the inner side of the door panel (figs. 13 and 14). On the Thunderbird, the guide on the inner door panel is adjustable.

When disconnecting the regulator arms at the glass channel, it is not necessary to completely disassemble the rollers unless the rollers themselves require service. Just pull the spring retainers out far enough to disengage the pins from the rollers (fig. 15). The rollers will remain on the glass channel.

The inner door panels on all models are covered with a plastic sheet, which eliminates the necessity for door access hole covers. Remove the sheet with care so that

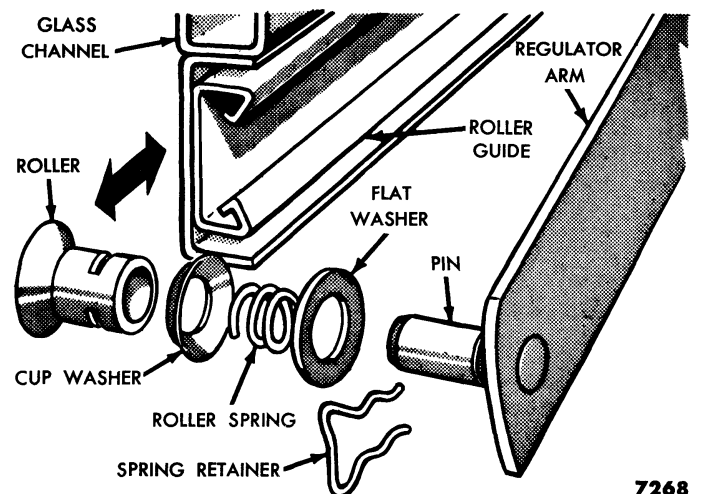

Fig. 15—Regulator Arm, Roller, and Guide

it can be replaced after performing glass or regulator repairs. If the sheet should become damaged or torn, replace it.

Glass and regulator failure is usually due to lack of lubrication, regulator out of adjustment, or misaligned glass runs. When performing operations on window regulators, always lubricate all moving parts of the mechanism with Lubriplate.

Complete regulator and glass replacement procedures are given in this section. The only adjustments included are those that are a part of the regulator replacement procedure. Complete door glass adjustments are given in section 5.

a. Front Door Window Regulator and Arm and Plate Assembly.

The window regulator and the arm and plate assembly (fig. 14) are serviced as separate assemblies.

(1) **ARM AND PLATE ASSEMBLY REPLACEMENT.** Remove the door trim panel. Remove the plastic sheet from the inner panel. Lower the glass and pull the spring retainers part way out of the rollers. Do not pull the spring retainers completely off the roller unless the rollers are to be serviced. Disconnect the regulator arms from the rollers, then raise the glass up out of the way. The rollers will remain on the glass channel. Hold the glass in the closed position with tape while servicing the arm and plate assembly. Remove the spring retainer that connects the regulator to the arm and plate assembly. Remove the three retaining screws, and slide the assembly toward the regulator to release the upper roller from the roller guide on the door panel. Lower the assembly out of the access hole.

NOTE: Before installing the arm and plate assembly, apply Lubriplate to the rollers and all pivot points.

If the rollers were disassembled, first assemble the rollers in the guides on the glass channels in the order shown (fig. 15). Raise the arm and plate assembly into the door.

Before locating the three retaining screw holes, start the upper roller into the roller guide. Install the three retaining screws but do not tighten them at this time. Connect the regulator link to the arm and plate assembly and install the retaining pin. Lower the window and engage the two regulator arms with the rollers in the glass channel assembly guides. Adjust the arm and plate assembly as outlined below. Install the door trim panel and hardware.

(2) **ARM AND PLATE ASSEMBLY ADJUSTMENT (EXCEPT THUNDERBIRD).** This adjustment corrects sagged glass and maintains proper parallel alignment of the glass in the runs to assure a freely operating glass.

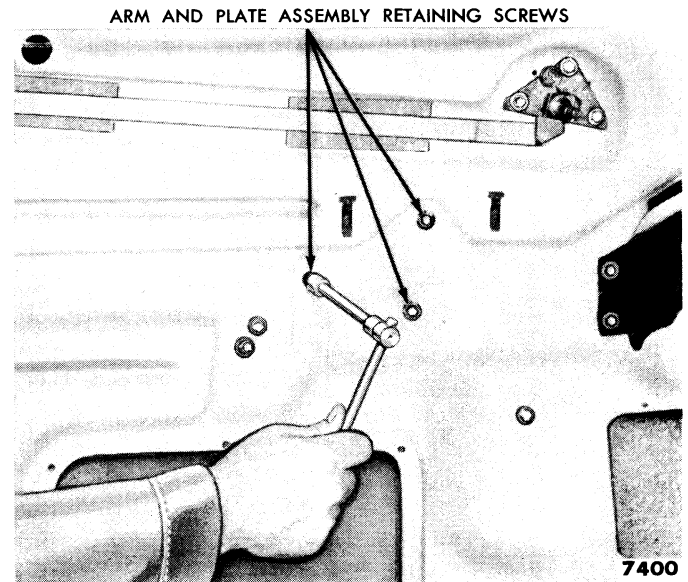

Fig. 16—Door Glass Sag Correction

Loosen the three retaining screws (fig. 16), raise the glass to within $\frac{1}{2}$ inch of the top, and observe the clearance. If the clearance is not the same from corner to corner, in relation to the top of the door, raise or lower the arm and plate assembly in the elongated holes. Tighten the retaining screws securely after making the adjustment.

(3) **DOOR WINDOW REGULATOR REPLACEMENT.** Remove the door trim panel. Remove the plastic sheet from the panel. Raise the door glass. Remove the spring retainer which secures the regulator arm link to the arm and plate assembly (fig. 14). Remove the regulator assembly retaining screws (fig. 17), and remove the regulator from the door.

Before installing the regulator, apply Lubriplate to the gear and shaft.

To install, raise the regulator assembly into the door panel. Position the connecting link between the inner

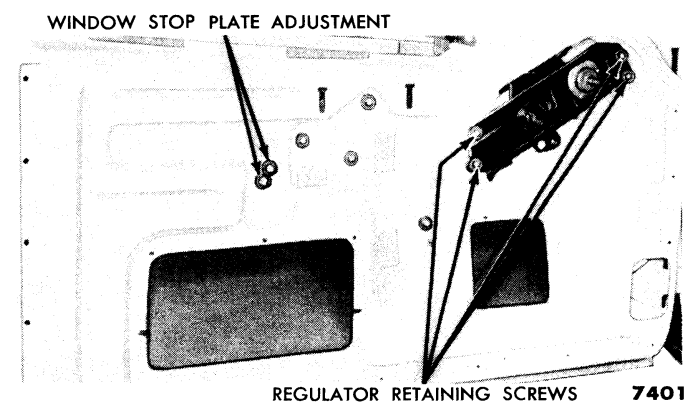

Fig. 17—Door Window Regulator Replacement

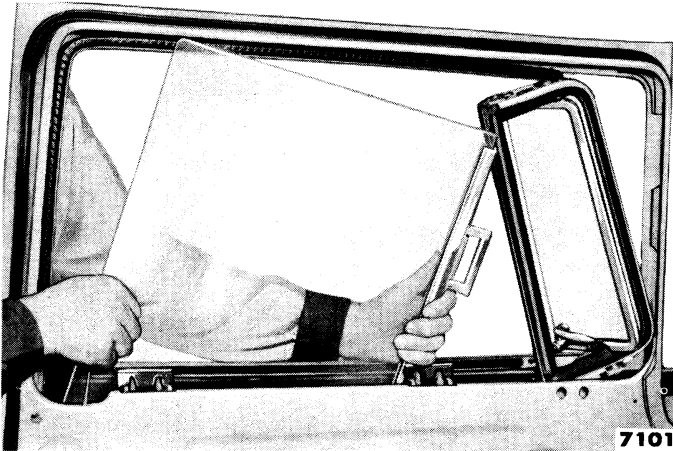

Fig. 18—Door Glass Replacement

panel and the division bar and fasten the link to the arm and plate assembly with the spring retainer (fig. 14). Install the retaining screws, but do not tighten them until the final regulator adjustment is made. Install the door trim panel and hardware after the adjustment.

(4) **DOOR WINDOW REGULATOR ADJUSTMENT.** The purpose for this adjustment is to allow additional upward glass travel. If the regulator has reached its travel limit and the window is not closed completely, loosen the four retaining screws (fig. 17). Raise the regulator assembly in the elongated holes. Tighten the retaining screws after final adjustment.

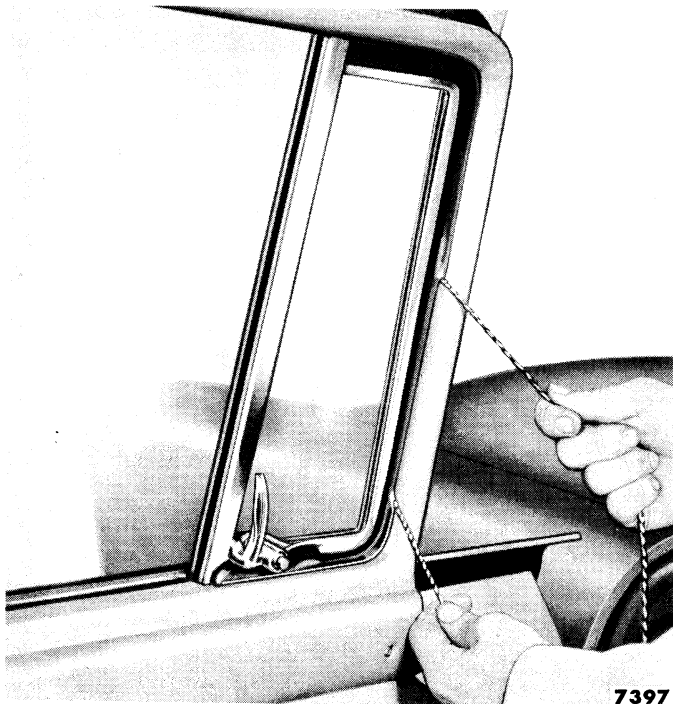

Fig. 19—Ventilator Weatherstrip Installation

b. Front Door Glass Replacement.

It is not necessary to disturb the ventilator assembly on Convertible or Victoria models, when replacing door glass.

(1) **REMOVAL.** Remove the garnish moulding and door trim panel. Remove the ventilator assembly retaining screws (except Convertible or Victoria models). Lower the door glass and disconnect the regulator arms from the rollers. Lift the glass to the closed position. Remove the lower window stop, and tilt the ventilator assembly inward so that the glass can be turned about 90 degrees as shown in fig. 18. With the glass in the position shown, tilt it slightly inward, and withdraw the assembly from the door panel. On Convertible and Victoria models, the glass can be drawn straight out after removing the two upper stops.

On the Thunderbird, loosen the lower pillar and tip the rear of the window in order to disengage the glass guide arm roller from its channel in the glass run assembly. Remove the glass from the door.

(2) **INSTALLATION.** Before installing the glass, assemble the rollers on the glass channel in the order shown (fig. 15). Lower the door glass into the door, being certain the glass is entered in the runs. Connect the regulator arms to the rollers on the glass channel. With the glass down, adjust the lower end of the division bar toward the glass until the glass has a minimum of end play and rides freely in the runs, repeat the adjustment with the glass raised, then install the ventilator assembly retaining screws. Raise the glass and check for proper fit along the top edge. If the door glass does not contact evenly along the top of the door (or roof on Victorias or Convertibles), adjust the window regulator. Install the door trim panel and hardware. Insert a draw cord around the inside of the ventilator weatherstrip. Pull the weatherstrip over the door on the outside. Position the garnish moulding on the door. Hold the garnish moulding tight against the ventilator weatherstrip, and draw the lip of the weatherstrip over the garnish moulding with the cord (fig. 19).

c. Rear Door Window Regulator.

The following replacement and adjustment procedures apply to the rear door regulators on both Fordor and Station Wagon models.

(1) **REPLACEMENT.** Remove the inside garnish moulding and trim panel. Remove the inside panel plastic sheet, and lower the window to gain access to the two rollers at "A" and "B" in the glass channel (fig. 13). Pull the spring retainers part way out of the rollers and release the regulator arms (fig. 13). The two rollers will remain in the glass channel unless they are to be serviced.

Once the window has been disconnected from the regulator arms, lift it up to the closed position so that it will be out of the way while servicing the regulator. The window can be held in this position with tape.

Remove the four regulator retaining screws, and slide the regulator arm and roller out of the guide that is welded to the inner door panel ("C", fig. 13). Remove the assembly from the access hole in the door panel.

Remove the roller from the pin on the end of the regulator arm at "C" (fig. 13). Install the roller on the corresponding pin of the replacement regulator. Before installing the regulator, the arms should be positioned in such a way that the pins at "A" and "B" are down, and the pin with the roller "C" is up—just the opposite from the position shown in fig. 13.

Enter the regulator through the access hole in the panel, and slide the roller (at the upper pin "C") into the guide on the door inner panel. Position the regulator to the door inner panel. Install the retaining screws, but do not tighten them at this time. Lower the glass and line up the regulator arms so that the pins at "A" and "B" will engage the rollers on the glass channel. The pins will snap into the rollers with slight hand pressure. Make certain that the spring retainer on the roller is properly seated in the groove on the pin. Adjust the regulator as outlined below, then install the interior trim.

(2) **ADJUSTMENT.** Loosen the regulator retaining screws (fig. 13). Shift the assembly in the elongated holes until the glass rides smoothly in the side runs and is even along the top. Tighten the regulator retaining screws.

d. Rear Door Glass.

Remove the inside garnish moulding and trim. Lower

the window glass and disconnect the regulator arms from the rollers at "A" and "B" (fig. 13). Loosen the division bar by removing the retaining screws at "E" and "F" and by loosening the lower bracket screw at "G" (fig. 13). Carefully lift the glass out of the door panel.

To install, lower the glass into the door and make certain the glass is entered into the runs. Connect the regulator arms to the rollers in the glass channel. Adjust the division bar so that the glass rides freely in the runs, then install and tighten the division bar mounting screws at "E", "F" and "G" (fig. 13).

e. Glass Run Replacement—Lock Side.

Remove the door glass, remove the retaining screws from the lower glass run assembly and remove the lower glass run through the access hole in the door (fig. 14). Remove the upper glass run with a screwdriver. Carefully pry the glass run clips free along the top and side of the door. Remove the run from the top of the door, then lift the assembly out of the door.

To install, carefully lower the upper glass run into the door. Make certain that the glass run is properly fastened at the upper and lower ends of the glass run retainer. Align the glass run clips in their holes.

Press the clips firmly in place. It may be necessary to cut the surplus felt from the end of the glass run so that the glass run will fit tightly against the top corner of the division bar.

Install the lower glass run assembly through the door access hole and secure it to the door panel with the retaining screws. Install the door glass and make the necessary adjustments.

5. DOOR GLASS ADJUSTMENTS

There are three basic glass adjustments common to all door windows. The top edge of the glass is adjusted parallel with the top edge of the door or roof rail. The glass runs are adjusted in and out and fore and aft to eliminate excessive end play or binding of the glass in the runs. Upper and lower travel adjustments are made to insure complete opening and closing of the window. The method of making these adjustments varies according to the particular door or model. The various procedures are outlined in this section.

a. Tudor and Fordor.

The window glass adjustments are basically the same for both front and rear doors. Slight differences are indicated in the procedures where they occur.

(1) **ALIGNMENT.** On both front and rear doors, raise the glass to within ½-inch from the top of the door and check to see if the top edge of the glass is parallel with the top edge of the door.

If misalignment or sag is evident on front doors, loosen the arm and plate assembly retaining screws, and either raise or lower the assembly in the elongated holes until the door glass is parallel with the top edge of the doors (figs. 14 and 16). If misalignment occurs on rear doors, loosen the regulator retaining screws and either raise or lower the assembly in the elongated holes for proper alignment (fig. 13). After positioning either the arm and plate assembly (on front doors) or the regulator assembly (on the rear doors) for proper alignment, tighten the retaining screws.

(2) **GLASS RUNS.** Raise the glass half-way up and observe the side-to-side movement between the glass runs. If the movement is excessive or if one edge of the glass is visible as the glass is forced in the opposite direction, follow the procedure under "(a) Excessive Clearance." If excessive force is required to raise or lower the glass, follow the procedure under "(b) Binding."

(a) **EXCESSIVE CLEARANCE.** Loosen the division bar mounting screws "E" and "F" (figs. 13 and 14). Move the division bar toward the door glass as far as the vent window will permit; that is, backward on front doors and forward on rear doors.

Lower the glass and check the side-to-side movement of the glass in the down position. If the clearance is excessive, loosen the screw that attaches the bracket extension to the door inner panel (fig. 11) or "G" (figs. 13 and 14). Shift the division bar toward the door glass, then tighten the screws.

Additional clearance can be taken up at the glass run on the lock side of the door by adding spacer washers between the glass run retaining tab and the bracket on the door face.

(b) **BINDING.** Loosen the upper and center division bar mounting screws and the adjusting screws at the lower division bar mounting bracket and extension (fig. 11) and "E", "F", "G" and "H" (figs. 13 and 14). The screw that attaches the bracket extension to the door inner panel moves forward or backward in an elongated hole in the door inner panel. Inward and outward adjustment is made possible by the division bar mounting bracket indexing in or out of its extension (fig. 11).

Lower the glass to align the division bar to the glass. Move the division bar bracket inward or outward in the extension and forward or backward in the door panel until the glass slides freely in the runs without excessive end play, then tighten all screws.

(3) **GLASS TRAVEL.** The downward travel of the door glass is controlled at the stop plate which is mounted in elongated holes (figs. 17 and 13). To make this adjustment, lower the glass to its lowest position.

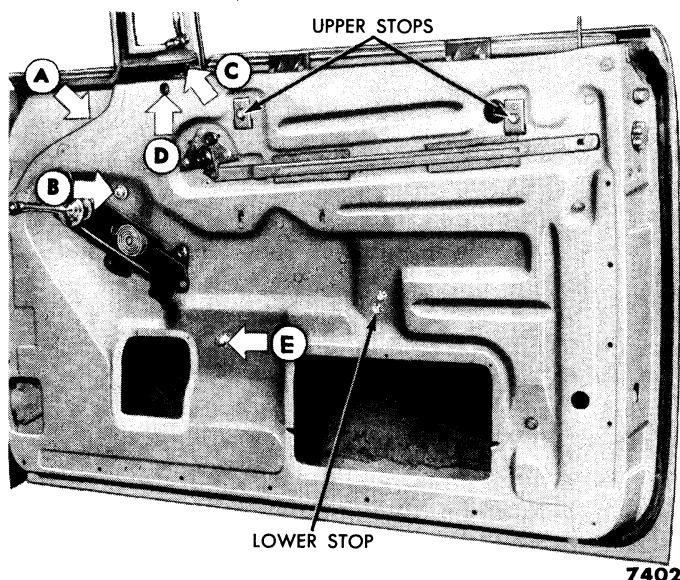

Fig. 20—Vent and Glass Travel Adjustments—Convertible and Victoria

If the top edge of the glass is not even with the top edge of the outer door panel, adjust the stop plate either up or down. Tighten the retaining screws.

After making the stop plate adjustment, raise the window to its highest position. If the regulator has reached the limit of its travel and the window is not completely closed, loosen the four regulator assembly retaining screws (figs. 17 and 13). Raise the regulator assembly in the elongated holes until the window closes completely, then tighten the retaining screws. When making this adjustment on rear windows, be careful to maintain proper window alignment (top edge of glass parallel with top edge of door).

b. Convertible and Victoria.

Convertible and Victoria door window mechanisms are basically the same.

Before attempting to perform door glass adjustments, be sure the top is properly aligned on Convertibles, and the weatherstrip in the Victoria roof side rails is properly aligned with the door glass. Make a visual inspection to see if the ventilator is parallel with the front pillar and the door glass is in alignment with the ventilator assembly and the quarter glass.

On Victoria models a mechanical weatherstrip assembly is installed along the roof side rail over the door. The inner side of the weatherstrip is stationary; the outer or "flipper" side opens and closes with the opening and closing of the door. The "flipper" is spring loaded to the open position and is controlled by the pressure of the vent window against the spring control lever. The upper side of the weatherstrip is equipped with elongated holes which permit the assembly to be adjusted forward and backward or in and out.

Usually the adjustment at either the door glass, ventilator assembly, or quarter glass will correct the trouble. In some cases, however, one adjustment may affect another. When making an adjustment at any particular location, check the related part, and adjust it to fit if necessary.

(1) **VENTILATOR ASSEMBLY ADJUSTMENT.** Before making any adjustment, loosen the screws at points "C", "D" and "E" and the lock nuts on the slotted shoulder bolts at points "A" and "B" (figs. 12 and 20).

To move the assembly forward (toward the front pillar), turn the shoulder bolt at "A" clockwise; to move the assembly backward (toward the door glass) turn the shoulder bolt counterclockwise. The bracket on the front leg of the assembly and the lower division bar bracket will make a corresponding shift in the elongated holes since the locknut and screw, at points "B" and "E" respectively, have been loosened.

To move the assembly in (toward the car) turn the shoulder bolt at "B" counterclockwise; to move the

assembly out (away from the car), turn the shoulder bolt clockwise. If necessary, loosen the screw at point "F" for a corresponding shift of the lower bracket in its extension (fig. 12).

To tilt the assembly forward or backward, leave the locknut at "B" tightened and turn the shoulder bolt at "A" clockwise or counterclockwise as required (figs. 12 and 20). To tilt the assembly in or out, leave the locknut at "A" tightened, loosen the bracket extension screw "F", and turn the shoulder bolt at "B" clockwise or counterclockwise as required (fig. 12).

After making any of the foregoing adjustments, tighten the lock nuts on the two shoulder bolts and all the retaining screws in order to secure the assembly to its new position.

(2) **DOOR GLASS ADJUSTMENTS.** The rear glass run assembly is adjustable in and out and fore and aft, at three points, as shown in fig. 21. If there is excessive end play between the rear glass run and the forward run in the division bar, move the rear glass run assembly forward in the elongated holes. If the glass binds, move the rear glass run backward. If the two glass runs are out of alignment with each other, adjust the rear run in or out as necessary. To move the top of the glass towards or away from the roof rail weatherstrip, adjust the rear glass run in or out at three adjustment points (fig. 21).

If the door glass is not parallel with the roof rail, (sagged door glass), loosen the arm and plate assembly retaining screws (fig. 22). Raise or lower the arm and plate assembly in the elongated holes until the upper edge of the door glass is parallel with the roof rail. Tighten the screws securely after completing the adjustment.

(3) **DOOR GLASS TRAVEL ADJUSTMENTS.** The up and down travel of the door glass is controlled by stop plates located on the door inner panel. Elongated holes permit up and down movement (fig. 20). To establish the correct height of the door glass travel, loosen the screw at each upper stop. Adjust the stop in the elongated hole so that the top edge of the glass does not extend beyond the ventilator assembly. To limit the downward travel of the door glass, loosen the screws at the lower stop (fig. 20). Adjust the stop in the elongated holes so that the top edge of the door glass is even with the top edge of the door.

c. Thunderbird.

The pillar assembly forms the forward glass run. The lock side glass run and the roller guide channel are incorporated in the glass run assembly (fig. 23). Glass binding is due to misalignment between the pillar assembly and the glass run assembly.

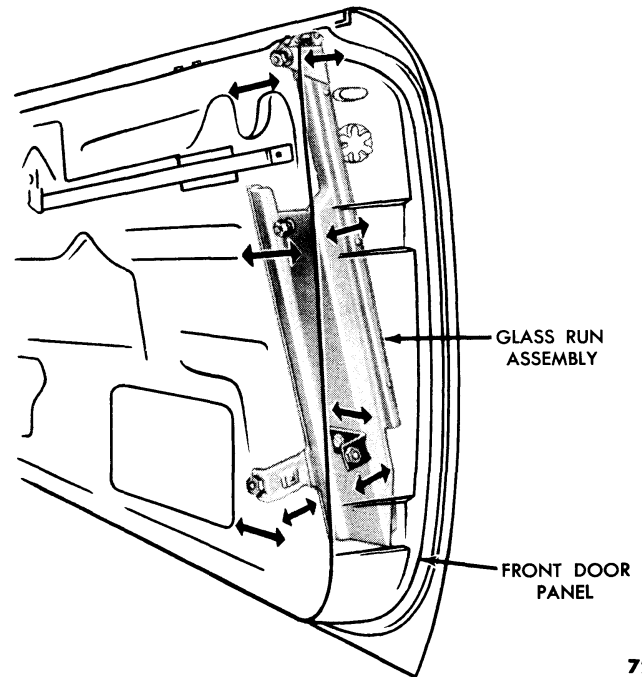

7277

Fig. 21—Convertible and Victoria Door Glass Run Adjustments—Lockside

Before adjusting for binds, the upper section of the door pillar assembly should be aligned with the windshield pillar. To align the upper door pillar to the windshield pillar in a forward and backward direction, loosen the screw "A" at the upper pillar bracket and the screw "C" at the lower pillar bracket (fig. 23). Move the pillar forward or backward as necessary, then tighten the screws. To align the pillar assembly to the windshield in a lateral direction, loosen the screw "B" at the upper pillar bracket and the two screws at the elongated holes

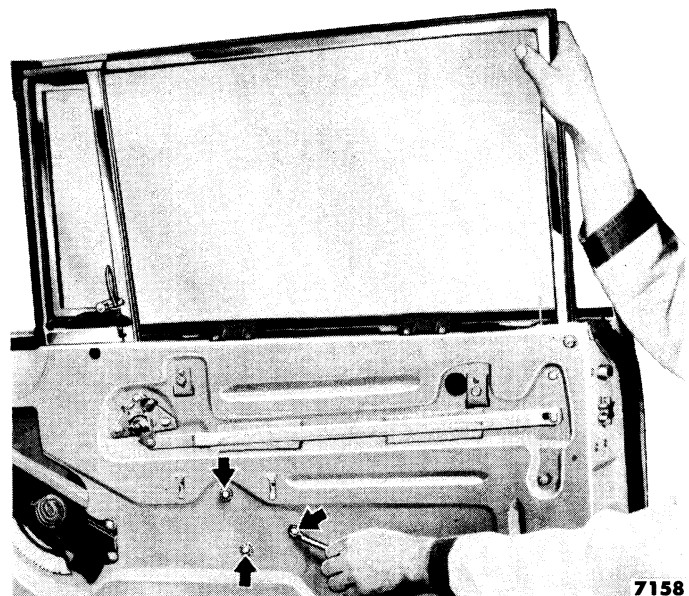

7158

Fig. 22—Door Glass Adjustment to Roof Rail

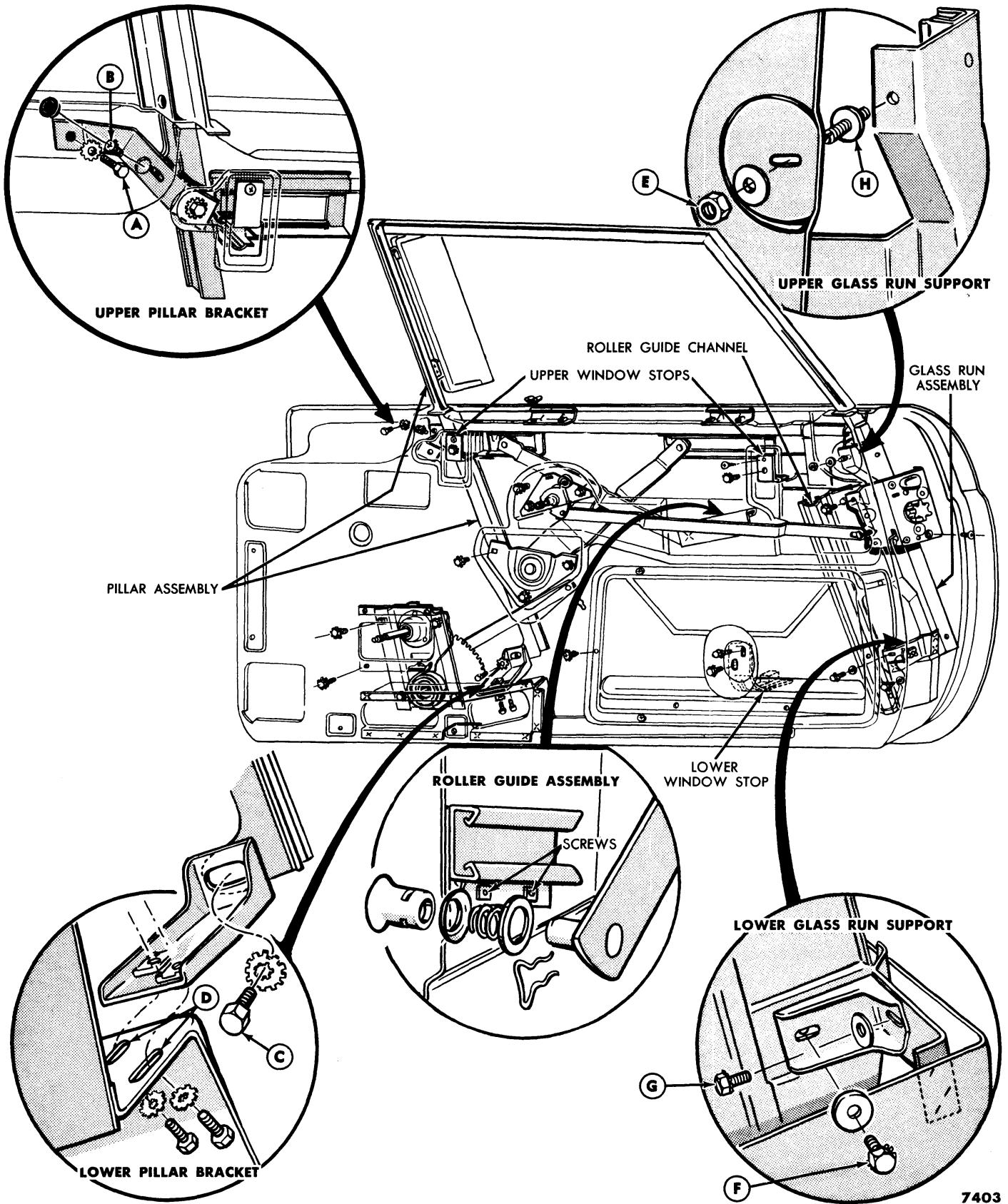

Fig. 23—Thunderbird Door Glass Adjustments

7403

“D” in the lower pillar bracket. Move the pillar in or out as necessary, then tighten the screws.

If, after aligning the door pillar assembly to the windshield pillar, the glass binds in the runs, the glass run assembly should be adjusted to line up with the door pillar assembly. For forward and backward adjustment, loosen the nut “E” at the upper glass run support and the screw “F” at the lower support. Move the glass run assembly forward or backward as necessary, then tighten the nut and screw. For lateral adjustment, loosen the screw “G” at the lower support and the nut “E” at the upper support. Turn the slotted shoulder bolt “H” in or out as required, then tighten the nut “E” on the shoulder bolt, and the screw “G” at the lower bracket.

If the door glass is not parallel to the roof rail, loosen the two screws that attach the roller guide assembly to the inner door panel. Move the guide in the enlarged holes in the panel until the proper adjustment is obtained, then tighten the screws.

Glass travel is controlled by two upper stops and one lower stop. If the window does not completely open at the end of regulator travel, adjust the lower window stop in the elongated holes so that the top edge of the door glass is even with the lower edge of the window opening.

If the window does not completely close, raise the two upper window stops until the window closes at the end of regulator travel.

6. QUARTER GLASS

Quarter glass and regulator service procedures are the same for all tudor sedan models. Since the Convertible and the Victoria each have a different type quarter glass and regulator assembly, separate replacement and adjustment procedures are given for these models.

a. Tudor.

Tudor quarter windows have the scissors type regulator the same as the rear door window. To replace the regulator, follow the rear door regulator replacement procedures previously given. The glass replacement and adjustment procedures are given here.

(1) **REPLACEMENT.** Remove the quarter trim panel. Lower the quarter glass and disconnect the regulator arms from the rollers on the glass channel. Care-

fully lift the quarter glass out of the panel (fig. 24).

Before installing the quarter glass, make certain the rollers are properly installed on the glass channel. This will simplify the installation procedure. Carefully lower the glass into the panel. Attach the glass channel rollers to the regulator arms. The spring retainers on the roller will snap into the groove on the regulator pin with slight hand pressure. Check and if necessary adjust the regulator so that the glass rides freely in the glass runs. Install the trim panel and hardware.

(2) **ADJUSTMENTS.** Adjustments are provided at the regulator assembly to maintain glass alignment in the side channels and also along the top.

(a) **REGULATOR.** Loosen the regulator retaining screws (fig. 25). Shift the assembly in the elongated holes until the glass rides smoothly in the side runs and is even along the top. Tighten the regulator retaining screws.

(b) **REAR GLASS RUN.** The rear glass run is also

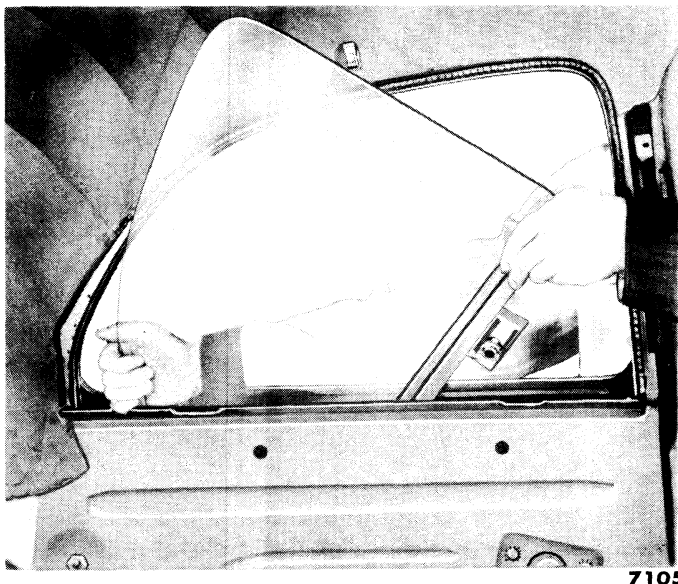

7105

Fig. 24—Tudor Quarter Glass Replacement

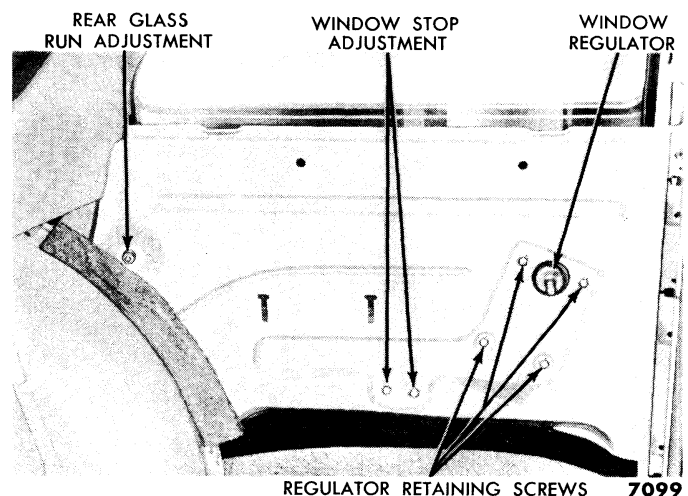

7099

Fig. 25—Tudor Quarter Window Adjustments

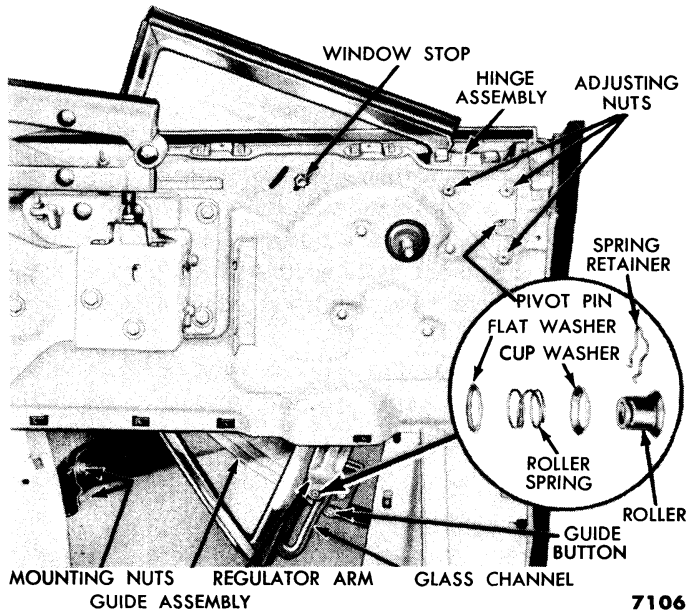

Fig. 26—Convertible Quarter Panel With Trim Removed

adjustable to take up any excessive end play between the runs (fig. 25). When regulator adjustments are made, check the end play. If necessary, adjust the rear glass run so that the glass is not loose between the runs.

(c) **STOP ADJUSTMENT.** The window stop (fig. 25) limits the downward travel of the glass. The window stop is mounted in elongated holes to permit up and down movement. The stop plate should be adjusted to obtain maximum downward travel of the window without allowing the window to contact the wheelhouse.

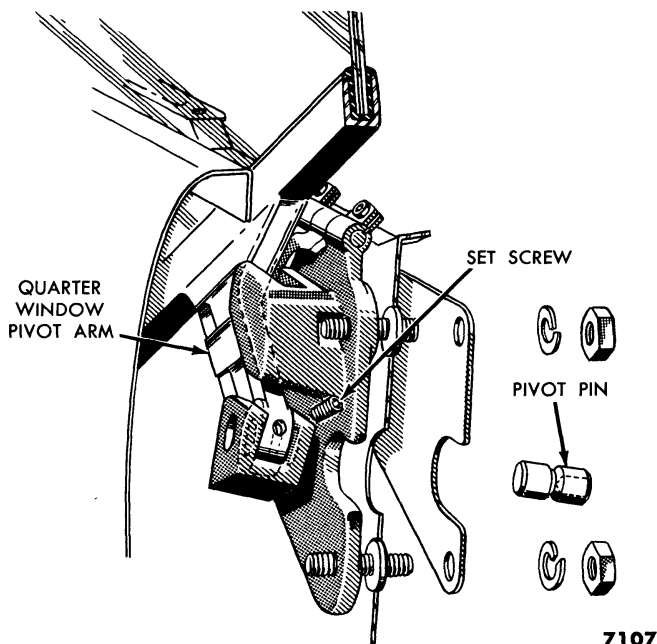

Fig. 27—Quarter Window Bracket and Hinge Assembly

b. Convertible.

Replacement and adjustment procedures for the Convertible quarter window are given here. The quarter window should be adjusted for correct alignment not only when it is operating improperly, but also after installation.

(1) **REPLACEMENT.** Remove the quarter trim panel. Disconnect the regulator arm from the roller in the glass channel (fig. 26). Loosen the screw at the pivot arm (fig. 27). Install a $\frac{1}{4}$ inch-20 bolt in the pivot pin and use it as a puller to remove the pivot pin (figs. 26 and 27). It may be necessary to raise and lower the glass to free the pivot pin. Remove the window stop. Remove the two screws from the guide button retainer, and remove the retainer and button assembly. Lift the window out of the quarter panel.

Before installing the quarter glass assembly, lubricate the pivot bracket with light engine oil, and assemble the roller to the glass channel. Position the pivot arm of the quarter window assembly in the pivot bracket with the hole in the arm aligned with the hole in the bracket, then install the pivot pin (fig. 27). Lower the glass in the runs, and connect the regulator arm to the roller in the glass channel.

(2) **ADJUSTMENT.** Before making any adjustment, loosen the guide assembly mounting nuts (fig. 26).

Raise the top, raise the window, and adjust the window to the top at the hinge bracket. To make this adjustment, loosen the lock nuts on the adjusting screws (figs. 26 and 27), and with an Allen wrench, turn the adjusting screws in or out as required to change the position of the hinge assembly. Since the quarter window assembly is mounted in the hinge assembly (fig. 27), any movement of the hinge will change the position of the window assembly. Enlarged holes in the hinge bracket and inner quarter panel permit fore and aft movement. By using any one of the three adjusting screws as a pivot and by adjusting the other two in or out, the window can be tilted at any desired angle.

After aligning the quarter glass to the top, lower the top, close the front door, raise the door window, and align the quarter glass to the door glass. This alignment can also be made by the fore and aft and tilting adjustments at the hinge and bracket assembly.

Since the guide assembly was loose, during the above procedures, it will have been adjusted automatically. Tighten the guide assembly mounting nuts.

c. Victoria.

The quarter glass and frame assembly on the Victoria moves in two tracks which are mounted on a removable panel assembly. Adjustment can be made without removing the panel assembly, but the panel assembly

must be removed to replace the glass. Be sure to adjust the glass for proper alignment after installing the panel assembly.

(1) **REPLACEMENT.** To remove the panel, lower the window to the open position, and remove the eight mounting screws (fig. 28). Slightly rotate the panel assembly as indicated by the curved arrow, then dismount the assembly from the quarter panel by moving it forward and out.

The window glass and frame assembly is attached to the removable panel through an arm link and bushing assembly at the front track and a bushing at the rear track (fig. 29). Remove the upper bushing retaining nut, and disengage the lobe-shaped portion of the glass frame from the arm link and bushing assembly at the front track. Remove the retaining nut and the bushing at the rear track. Remove the glass and frame assembly from the panel.

Attach the rear end of the glass and frame assembly to the rear track with the bushing and retaining nut (fig. 29). At the front track, connect the arm link, then connect the glass and frame assembly to the upper bushing stud. At the same time, engage the guide bracket to the lobe-shaped portion of the glass and frame assembly. Secure the glass frame and arm link to the upper bushing with the retaining nut.

Slant the window and regulator panel slightly upward and forward of the quarter panel, then slide the rear track into the rear end of the quarter panel. Rotate the assembly into position, and secure it to the quarter panel with the mounting screws (fig. 28).

(2) **ADJUSTMENT.** Position the entire panel assembly in proper relation to the contour of the window opening, then center the glass assembly to the glass runs.

(a) **PANEL ALIGNMENT.** Raise the window to the closed position, and loosen the eight mounting screws (fig. 28). Slide the panel assembly forward or backward and up or down as required to fit the window glass and frame assembly to the contour of the window opening. Lateral misalignment of the glass and frame assembly

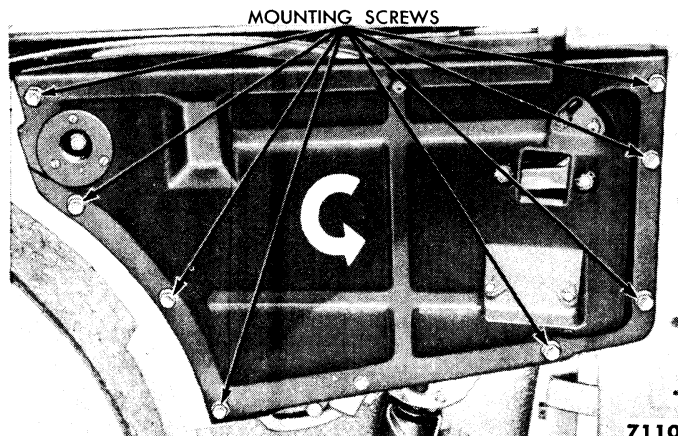

Fig. 28—Victoria Window and Regulator Panel

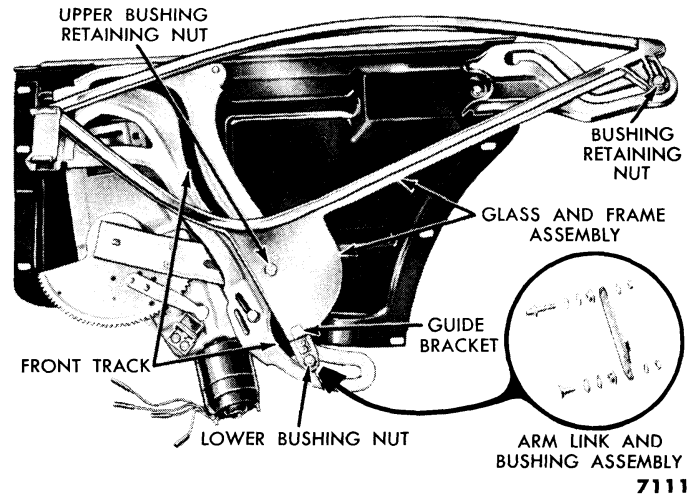

Fig. 29—Removal of Glass and Frame Assembly—Victoria

may prevent a perfect fit. In such a case, position the panel so that the glass will follow the contour of the window opening as closely as possible; then tighten four of the eight mounting screws to maintain the preliminary adjustment while the glass is being aligned. After the glass frame assembly has been adjusted to the glass runs, loosen the mounting screws, and complete the panel adjustment.

(b) **GLASS ALIGNMENT.** Loosen the lock nuts at the four adjusting screws (fig. 30), and raise and lower the window to determine where the glass binds in the runs. Turn the adjusting screws in or out to center the glass in the runs. The rear track and upper front track adjusting screws will bring the glass into approximate alignment with the glass run in the roof panel. The forward and lower front track adjusting screws will bring the glass into approximate alignment with the glass run in the quarter lock pillar. A combination of adjustments, at all four points, will move the glass to any desired angle for a final centering of the glass in the runs.

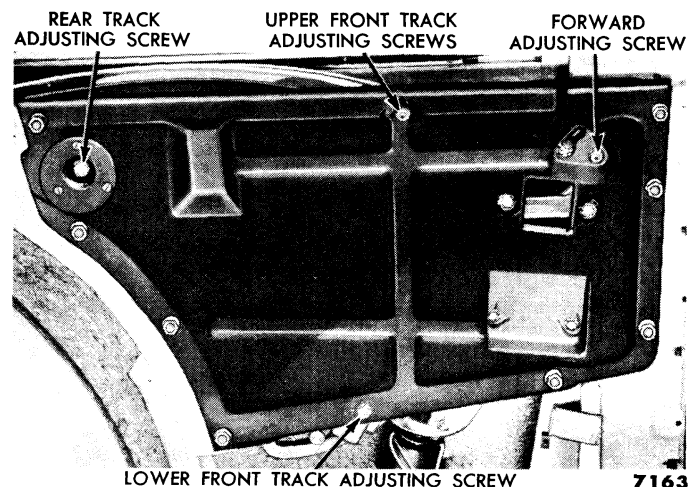

Fig. 30—Victoria Quarter Window Adjustments

e. Ranch Wagon, Country Sedan, and Country Squire Quarter Glass.

The quarter window consists of a stationary window and a sliding window. The sliding window is held in the body by glass runs (fig. 31). The stationary glass is mounted in a rubber weatherstrip and is held in the body by the garnish moulding. It is important that the quarter windows are sealed properly to avoid water leaks. Drain holes along the bottom body flange must be open to allow proper drainage.

(1) **STATIONARY GLASS REPLACEMENT.** Remove the garnish moulding retaining screws, then remove the garnish moulding assembly. Press the upper end of the stationary glass out of the body, working from the outer side of the body. Before installing the stationary glass, remove all old sealer material and rubber cement from the body opening and glass weatherstrip. Apply an adequate amount of rubber cement (8A-19552-B) between the glass and weatherstrip. Also apply a bead of water resistant sealer (M-5398-A) around the opening in the body. Position the stationary glass in the body opening, then press it firmly to assure a good seal. Apply an additional bead of sealer on the inner side along the bottom. Install the garnish mould-

ing assembly. Clean all sealer and cement from the glass.

(2) **SLIDING GLASS REPLACEMENT.** Remove the garnish moulding assembly and stationary glass. Slide the glass in the glass run to expose the upper glass run retaining screws (fig. 31). Remove the retaining screws from the upper glass run only. Working from the outer side, press the upper end of the sliding glass and upper glass run out of the body, then lift the glass and lower run assembly out of the body opening. It may be necessary to pry the seal loose between the glass run and body opening in order to remove the assembly. Separate the glass from the lower glass run.

Before installing the sliding glass, remove all old sealer from the body opening. Apply a bead of sealer (M-5398-A) around the body opening. Position the upper glass run on the sliding glass. Insert the bottom edge of the glass into the lower glass run, then press the upper end of the glass and glass run into the body opening. When installing the glass run retaining screws, be sure to embed them in the run far enough to prevent the glass from striking the heads of the screws. Apply an additional bead of sealer (M-5398-A) on the inner side along the bottom. Install the stationary glass and garnish moulding assembly.

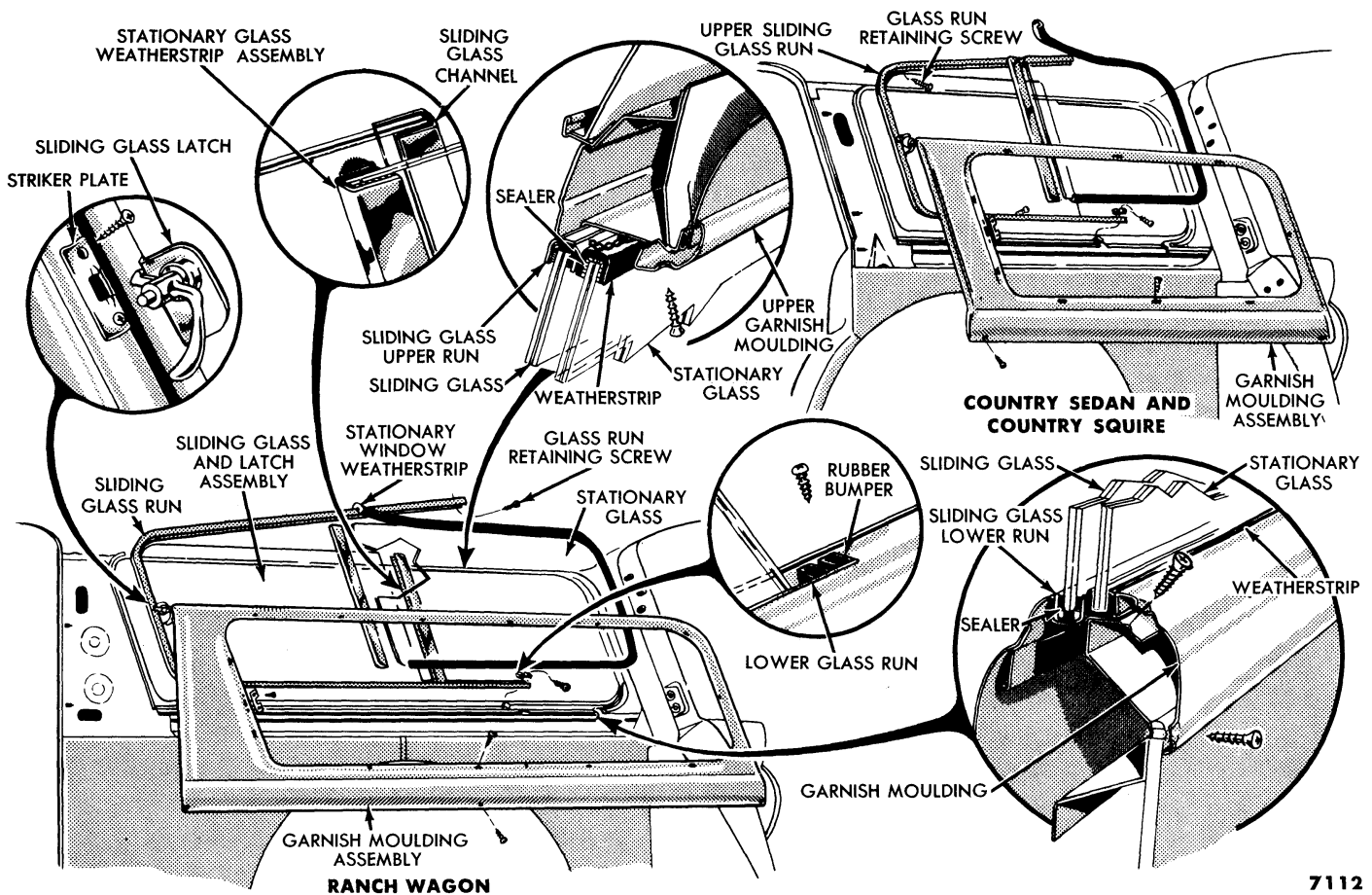

7112

Fig. 31—Stationary and Sliding Glass

7. WINDSHIELD AND REAR WINDOW

When installing windshield and rear window glass, several precautions are necessary to ensure proper sealing against water leaks. It is essential that old cement and broken glass be removed from the glass channel in the rubber weatherstrip. The body flange should be inspected thoroughly for roughness or uneven edges. It is recommended that genuine Ford approved glass be used to ensure proper fit in the body.

a. Windshield Replacement.

The basic removal and installation procedures apply to all body types. However, the design and assembly of the outside trim moulding varies according to model.

The following preliminary steps must be performed on all models:

Place a protective cover over the hood to prevent damaging the paint. Remove the inside rear view mirror and all inside garnish mouldings. Remove the windshield-wiper arms.

NOTE: *When removing the interior garnish mouldings, note the length of the screws and see that they are installed in their original locations.*

The Mainline series has no outside windshield moulding. Therefore, when servicing any mainline windshield, skip step "(1) Trim Moulding Disassembly," and proceed with step "(2) Removal" immediately after performing the preliminary steps. On all other models, follow the applicable trim moulding disassembly procedure, then proceed to "(2) Removal."

(1) **TRIM MOULDING DISASSEMBLY.** The following paragraphs give a separate procedure for each body type .

(a) **CUSTOMLINE, AND FAIRLANE EXCEPT CONVERTIBLE AND VICTORIA.** Remove the side moulding retaining screws from the rear face of each front pillar, then remove the side mouldings (fig. 32). Remove the belt moulding retaining screws from the side face of each front pillar. The top and belt mouldings can be removed from the weatherstrip after the windshield assembly has been pushed out of the body.

(b) **CONVERTIBLE.** With the upper inside garnish moulding removed, remove the screws and the upper garnish moulding weatherstrip retainers (fig. 33), then remove the garnish moulding weatherstrip ("A" fig. 33).

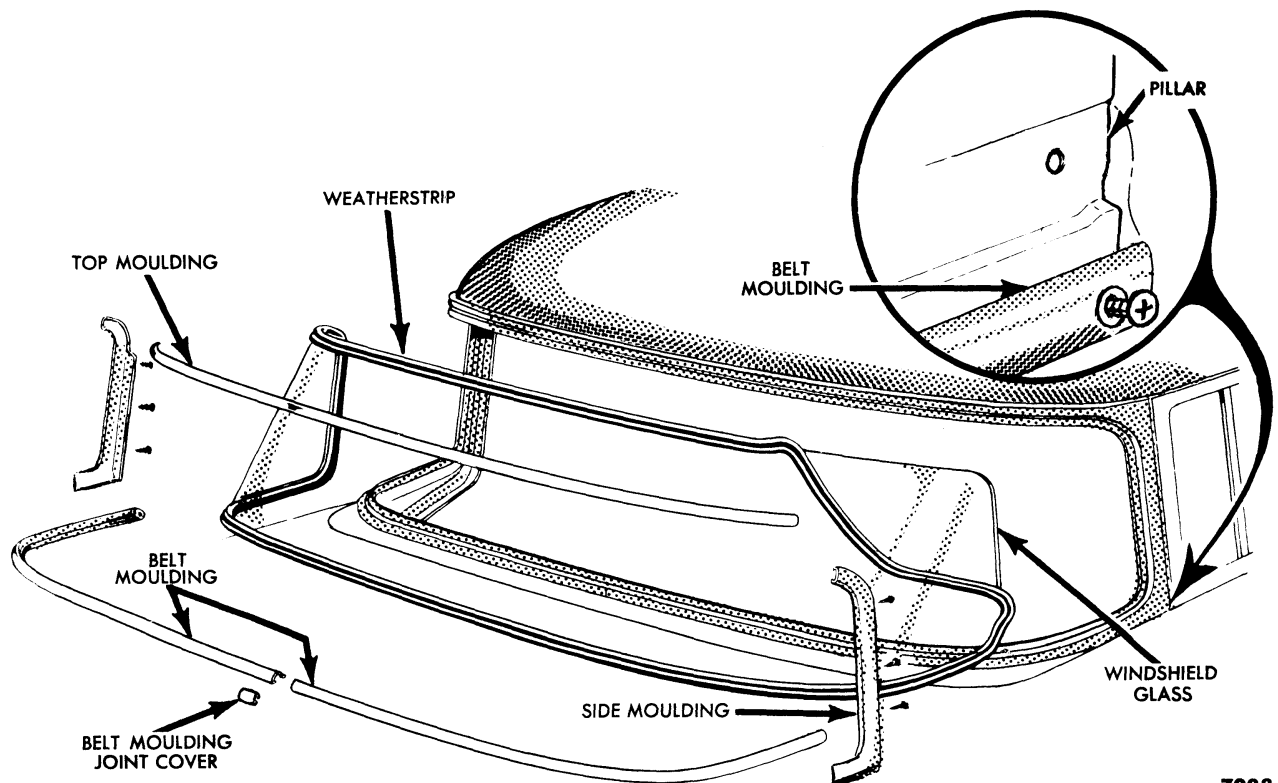

7288

Fig. 32—Disassembled View of Windshield—Except Convertible, Victoria and Thunderbird

Remove the retaining screws, disengage the side moulding retainers from the clips, and remove the side mouldings ("B" fig. 33). Remove the retaining screws at each end of the top moulding, and remove the top moulding ("C" fig. 33). Remove the retaining screws at each end of the belt moulding.

(c) **VICTORIA MODELS.** Remove the retaining screws and the two windshield side mouldings, then remove the screw from each end of the belt moulding ("A" fig. 34). The top moulding is assembled to the body by retainer assemblies ("B" fig. 34). Since the top moulding holds the weatherstrip against the body flange, the moulding must be removed before the windshield can be removed. Pull back the headlining along the top edge of the windshield, and remove the nuts and washers from the retainer assemblies ("B" fig. 34). Remove the top moulding and retainers from the body.

(d) **THUNDERBIRD.** Remove the retaining screws from the top moulding, disengage the moulding retaining clips from the moulding retainer ("B" fig. 35), and remove the top moulding. Remove the instrument panel extension plate and the rear finish moulding from each side of the windshield. Remove the belt moulding joint

cover at each side moulding. Remove the retaining screws from each side moulding, and disengage the side moulding clips from the moulding retainer ("A" fig. 35). Remove the side mouldings.

(2) **REMOVAL.** Loosen the inner side of the weatherstrip around the body flange, and apply pressure, with the flat of the hand, at the upper inside corner of the windshield (fig. 36). After the glass is out at the corner, continue to apply pressure, working toward the center, until the glass is completely off the body flange. Remove the trim mouldings from the weatherstrip (if so equipped). Remove the glass from the weatherstrip.

(3) **INSTALLATION.** Before installing the windshield, clean all the old cement and broken glass from the body flange and the channel in the rubber. Inspect the body flange for rough or uneven edges. Straighten any uneven edges with pliers.

Stretch the weatherstrip around the glass. Be certain the glass is well embedded in the channel. Apply rubber cement (8A-19552-B) between the glass and weatherstrip on both sides of the glass.

On the Customline series and the Fairlane series (except Victoria and Convertible) assemble the outside

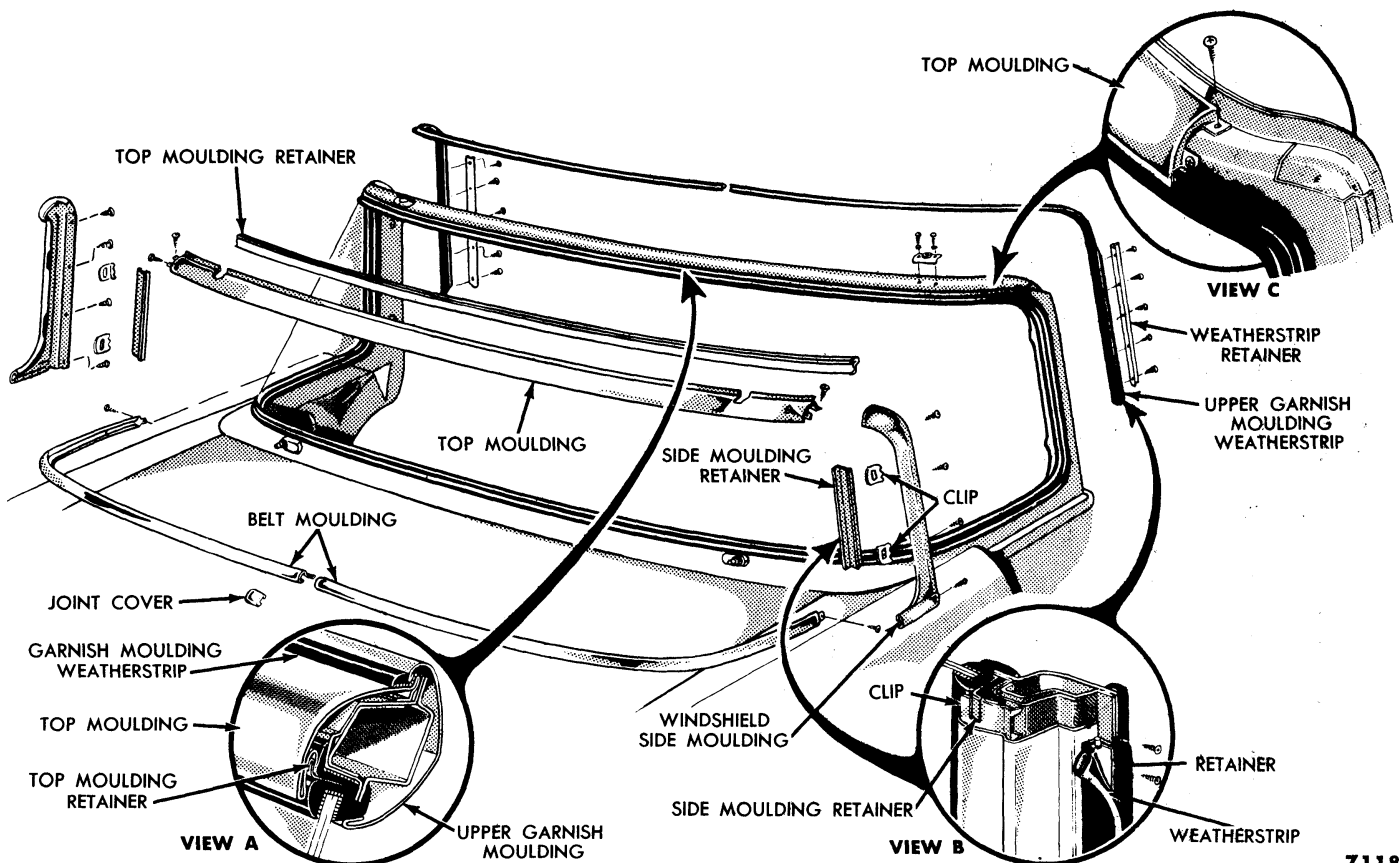

Fig. 33—Disassembled View of Windshield—Convertible

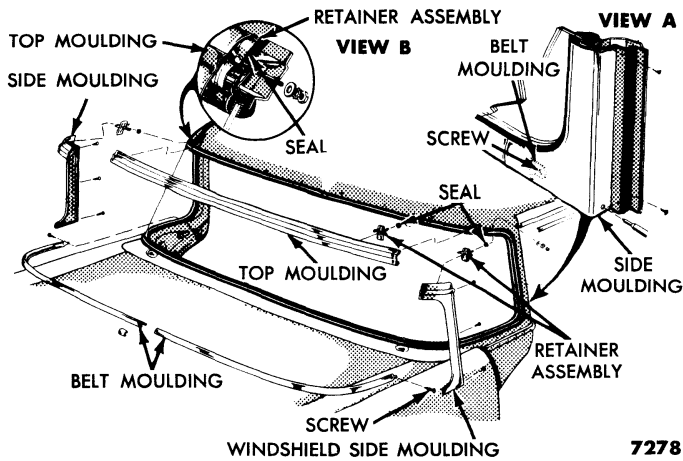

Fig. 34—Disassembled View of Windshield—Victoria Models

belt moulding and the top moulding to the weatherstrip before installing the windshield in the body. Insert both of these mouldings in the weatherstrip as shown in fig. 37.

On the Convertible and Victoria, assemble only the outside belt moulding to the weatherstrip before installing the windshield. Do not install side mouldings on any model, until after the windshield is installed in the body.

On the Convertible, the retainers for both the side moulding and the top moulding must be inserted in the weatherstrip at this time (fig. 33). Also, the top moulding retainer on the Thunderbird must be inserted in the weatherstrip at this time (fig. 35).

Before positioning the windshield on the body, apply several pieces of masking tape at each lower corner of

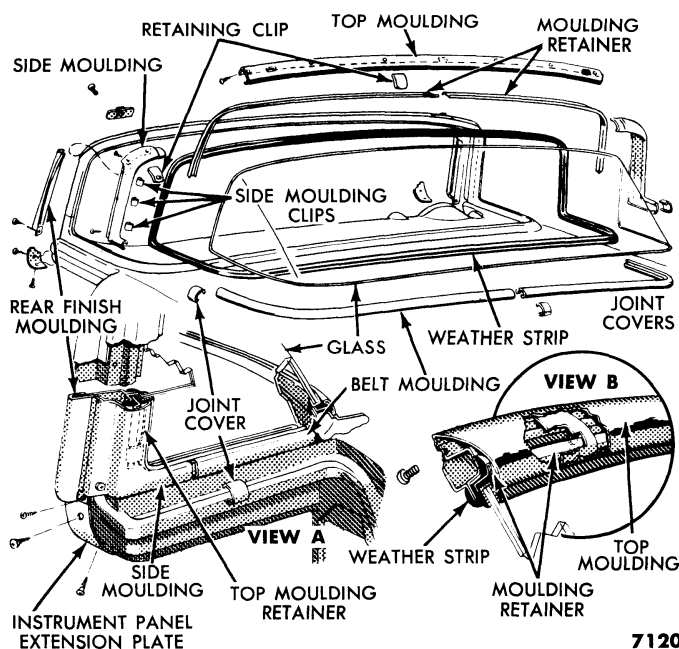

Fig. 35—Disassembled View of Windshield—Thunderbird

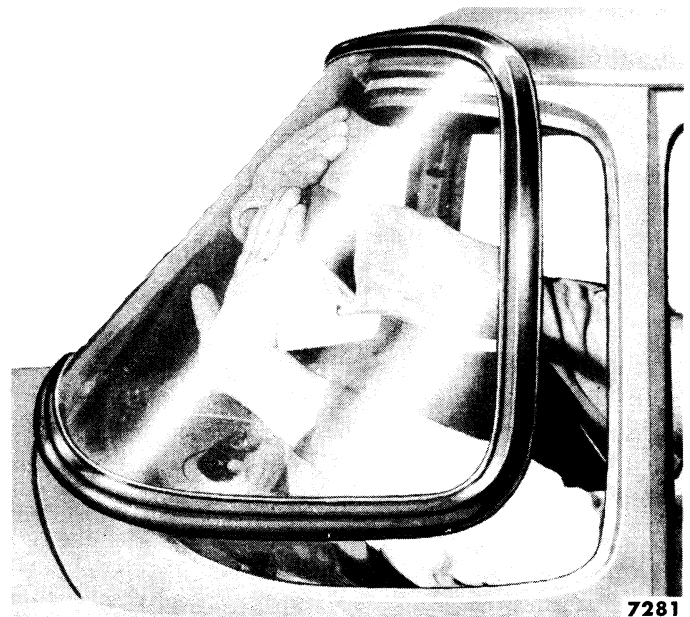

Fig. 36—Windshield Removal

the front pillar to avoid scratching the paint with the ends of the belt moulding (except Mainline). Install a strong cord (chalk line) completely around the inner lip of the weatherstrip, and position the windshield in the opening as shown in fig. 38.

NOTE: A light application of liquid soap to the weatherstrip will facilitate installation. Do not use oil or grease.

Press the glass firmly against the body flange, then pull the cord, starting along the top and working around the corners, as shown in fig. 39. After withdrawing the cord, carefully strike the glass with the palm of the hand to seat the weatherstrip tightly over the body flange.

If a Mainline windshield is being installed, immediately perform the final steps at this point. In the case of

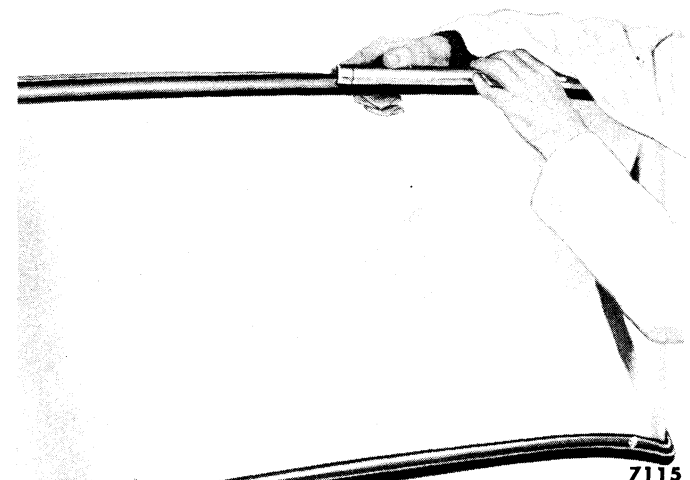

Fig. 37—Outside Belt Moulding Installation

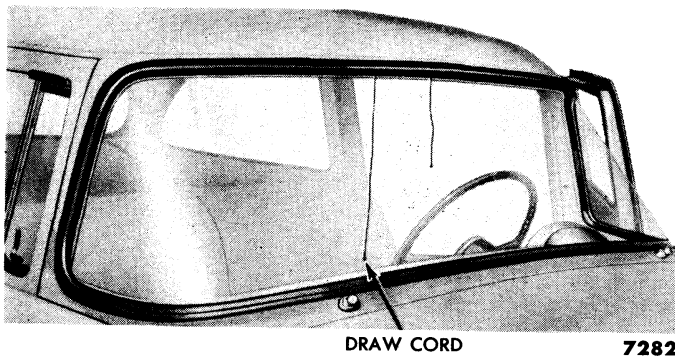

Fig. 38—Windshield Ready for Installation

other models, follow the applicable trim moulding assembly procedure then perform the final steps.

The final steps are as follows:

Position the rubber plugs at each end of the defroster slot. Install the inside finish strips. Draw the screws up uniform and snug, but not excessively tight. Install the wiper arm assembly. Remove excess cement, and water-test for leaks.

(4) **TRIM MOULDING ASSEMBLY.** The following paragraphs give a separate procedure for each body type. After the outside trim moulding has been assembled to the windshield, perform the final steps as given in the preceding paragraph.

(a) **CUSTOMLINE, AND FAIRLANE EXCEPT CONVER-**

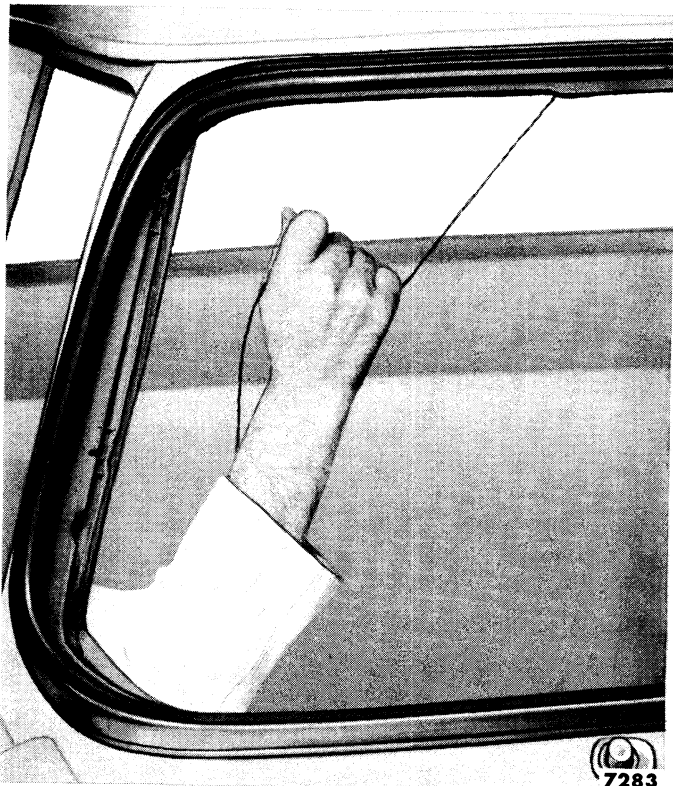

Fig. 39—Pulling the Draw Cord

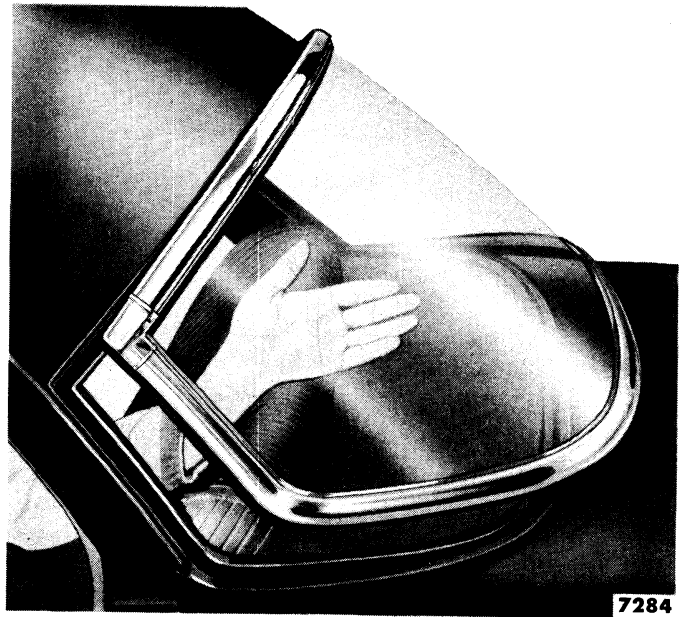

Fig. 40—Rear Window Removal

TIBLE AND VICTORIA. Secure the ends of the belt moulding to the side face of each front pillar with retaining screws (fig. 32). Slide the top and bottom ends of the side mouldings over the ends of the top and belt mouldings respectively. Position the rear flanges of the side mouldings to the rear face of each front pillar, and install the retaining screws.

(b) **CONVERTIBLE.** Install the top moulding to the retainer and secure the ends of the moulding to the windshield frame with screws ("C" fig. 33). Secure the ends of the belt moulding to the side face of each pillar with

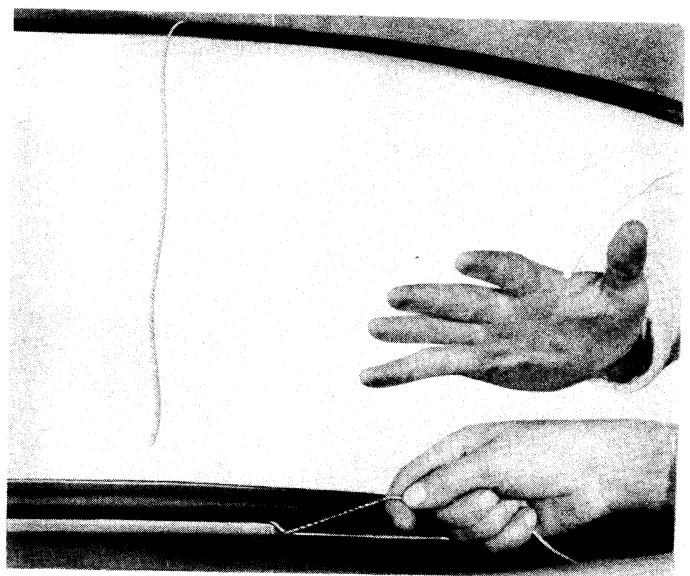

Fig. 41—Rear Window Installation

screws. Install the two clips in the side mouldings, position the mouldings in place, and fasten the clips to the side moulding retainers in the weatherstrip ("B" fig. 33). Install the side moulding screws. Install the upper garnish moulding and weatherstrip ("A" fig. 33), install the garnish moulding weatherstrip retainers, and secure them with screws.

(c) **VICTORIA MODELS.** On the Victoria, position the retainer assemblies in the top moulding. Place the top moulding on the roof panel so that the retainer studs will enter the holes above the windshield opening ("B" fig. 34). Install nuts and washers on the studs, and replace the headlining along the inner edge of the windshield. Secure each end of the belt moulding with a screw, and install the two side mouldings with the retaining screws ("A" fig. 34). If a new belt moulding assembly is being installed, use the old moulding as a template, and drill the retainer screw holes ($\frac{1}{8}$ inch) in the new moulding.

If a new side moulding is being installed, use the old moulding as a template and counter-punch the retainer screw holes in the replacement assembly.

(d) **THUNDERBIRD.** Install the clips in the side mouldings, and attach the clips to the retainer in the weatherstrip. Install the side moulding retaining screws and the belt moulding joint cover at each side moulding ("A" fig. 35). Install and position the retaining clips in the top moulding, mount the top moulding in place, and engage the clips to the moulding retainer in the weatherstrip. Install the top moulding retaining screws ("B" fig. 35). Install the rear finish moulding and the instrument panel extension plate at each side of the windshield.

b. Rear Window Replacement.

The basic replacement procedures are the same for all models. On all except the Mainline series, the rear window is equipped with outside trim mouldings which are removed from the weatherstrip after the window assembly has been removed from the car.

(1) **REMOVAL.** From inside the car, apply pressure with the hand against a corner of the rear window, as shown in fig. 40, until the weatherstrip begins to roll off the body flange. Moving toward the opposite end, continue to apply pressure until the weatherstrip is completely off the body flange.

If equipped with trim mouldings, pry off the joint covers and remove the mouldings from the weatherstrip. Remove the weatherstrip from the glass.

(2) **INSTALLATION.** Clean the channel in the weatherstrip and the body flange. Stretch the weatherstrip over the glass. Make sure the glass is seated firmly in the weatherstrip. Apply rubber cement (8A-19552-B) between the glass and weatherstrip on both sides of the glass. If equipped with trim mouldings, install the mouldings in the weatherstrip, then fasten the joint covers to the mouldings.

Insert a piece of cord (chalk line) around the inner lip of the weatherstrip, allowing both ends of the cord to overlap. Apply liquid soap around the inner side of the weatherstrip. Position the glass on the body and, while an assistant withdraws the cord to pull the weatherstrip over the body flange, push the window firmly against the body (fig. 41).

After pulling the cord, carefully strike the glass with the palm of the hand to seat the weatherstrip over the body flange. Clean the window, then water test the vehicle and check for leaks.

Part FOUR

BODIES

Chapter

III

Removable Sheet Metal Assemblies

Section		Page
1	Door Replacement and Alignment	313
2	Door Locking Mechanism	317
3	Luggage Compartment Door Replacement and Alignment	320
4	Luggage Compartment Door Locking Mechanism and Handle	323
5	Grille and Hood	324
6	Hood Alignment and Lock Adjustment	326
7	Thunderbird Grille and Hood	328
8	Front Fenders	329

This chapter presents the replacement and adjustment procedures for all sheet metal parts that are normally replaced as a separate assembly. Three of these assemblies, namely, the doors, luggage compartment door, and hood are equipped with locking mechanisms. The door and luggage compartment door locks are com-

plete sub-assemblies and are, therefore, discussed separately. Since hood, and hood lock operation, are closely related, the hood locking mechanism is discussed in the same section with hood alignment. Another section covers replacement of the hood and grille.

I. DOOR REPLACEMENT AND ALIGNMENT

Door alignment is an important part of the replacement procedure. Also, when a door is being installed and aligned, the striker plate must be adjusted to the new door position.

To correct door misalignment, either of two procedures can be followed, depending upon the condition of the door. One is minor alignment which can usually be accomplished by adjusting the door hinges or striker plate. The other is major door alignment which requires changing the contour of the door by the use of special tools. Before aligning the door, a visual inspection will indicate which type of correction is required. If the door is twisted or bent out of shape, a hinge adjustment (minor alignment) will not correct the condition. It will then be necessary to straighten the door as outlined in "c. Major Door Alignment."

Before attempting adjustments on any door, inspect the fit of the door against the weatherstrip. Insert a piece of paper between the door and the weatherstrip (fig. 1). If the door is properly sealed against the weatherstrip, the paper should pull out with a slight drag. Make this check at several points around the door as shown.

a. Door Replacement.

A replacement door is delivered as a sheet metal shell with only a prime coat of paint and without hinges,

trim, glass, or hardware parts. All usable parts should be transferred from the old door to the replacement door.

(1) **REMOVAL.** Remove the window regulator handle, the door remote control handle, and the arm rest. Remove the garnish moulding and spacers and the door trim panel. Remove all re-usable glass or hardware parts.

(a) **FRONT DOOR.** If the outside trim moulding is not damaged, remove it with a putty knife. Remove all re-usable moulding clips.

Remove the rivet that attaches the door check arm to the check arm bracket (fig. 2). Slide the arm out of the guide assembly into the inner door panel, and remove the arm through the door access hole. Remove the cover plate from the inner door panel at the top hinge and the access plate at the bottom hinge. Remove the six door to hinge bolts (fig. 3), and lift the door from the hinges. If a hinge is damaged, remove the three hinge to pillar bolts, and remove the hinge.

(b) **REAR DOOR.** If the outer door moulding is not damaged, remove it from the clips with a putty knife. Remove all re-usable moulding clips.

Remove the rivet that attaches the door check arm to the check arm bracket (fig. 2). Slide the arm out of the guide assembly into the inner door panel, and remove the arm through the door access hole. Remove the

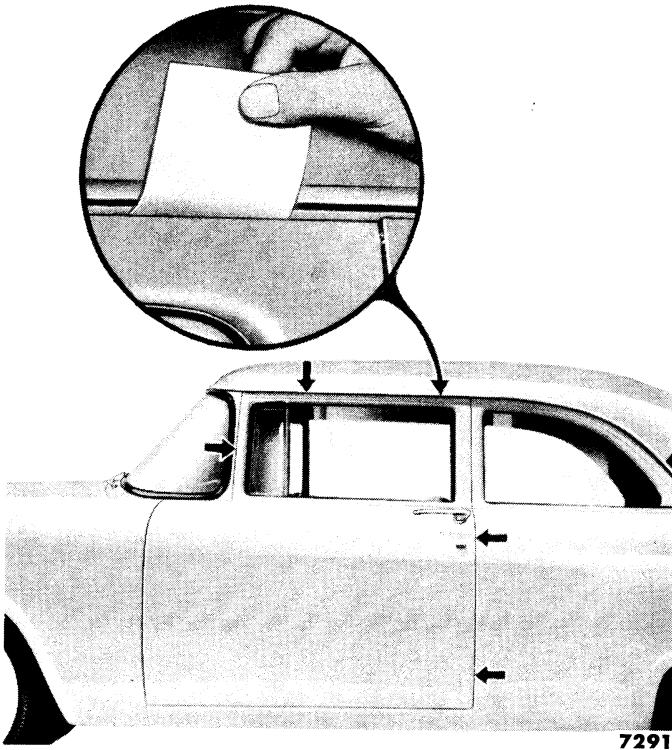
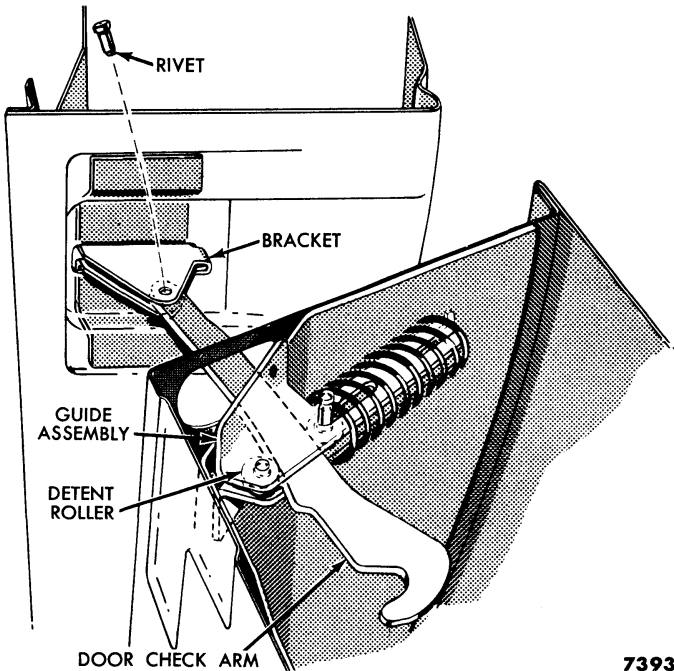

Fig. 1—Door Weatherstrip Seal Check

bolts and washers that attach the hinges to the door, and remove the door (fig. 4). If a hinge is damaged, remove the center pillar trim panel, remove the hinge to pillar bolts and washers, then remove the hinge from the central pillar.



7393

Fig. 2—Front Door Check Arm Installation—Typical of Rear Door

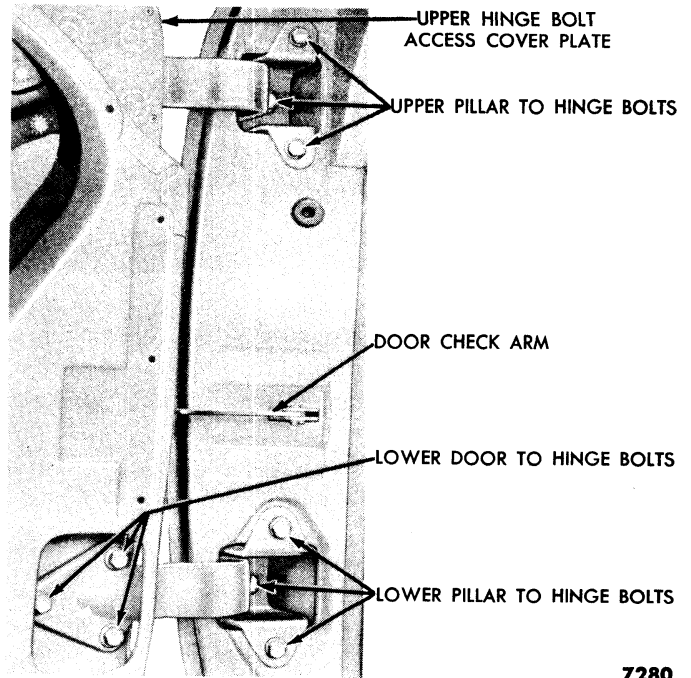

7280

Fig. 3—Front Door Hinge Mounting

(2) **INSTALLATION.** If the removed door was equipped with an outside trim moulding, drill the necessary holes in the replacement door for the moulding retaining clips.

Spray the replacement door with paint that matches the color of the car.

Working from inside the door panel through the door access hole, install the door check arm through the guide assembly (fig. 2).

Apply cement to the door flange, the rubber weatherstrip, and the remote control recess in the inner panel. Attach the weatherstrip to the door flange, and install the remote control anti-rattle pad.

(a) **FRONT DOOR.** Install the two hinges in the front pillar. Position the door on the hinges, and attach it with bolts and flat washers at each hinge (fig. 3). If the

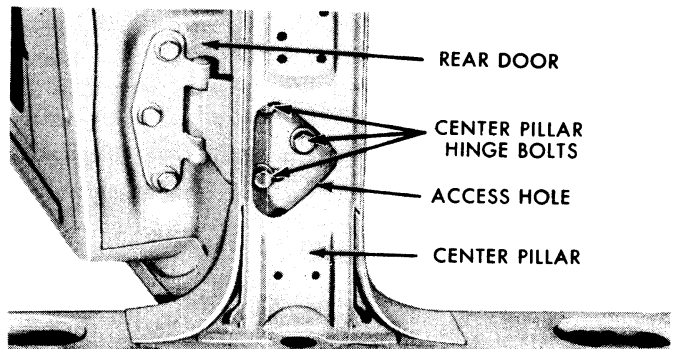

4355

Fig. 4—Rear Door Hinge Mounting

BODY BOLT NUMBERS AND MODELS USED ON:

NO. 1—ALL MODELS
 NO. 2—ALL MODELS
 NO. 3—ALL MODELS
 NO. 4—ALL MODELS
 NO. 4A—MODELS BN 60, 64 AND 76
 NO. 5—ALL MODELS
 NO. 5A—MODELS BN 60, 64 AND 76

NO. 6—ALL MODELS
 NO. 7—ALL MODELS
 NO. 8—LOCATION (1)—MODELS BN 60, 64, 70, 73 AND 76
 NO. 8—LOCATION (2)—MODELS BN 59, 78 AND 79
 NO. 9—LOCATION (1)—MODELS BN 60, 64, 70, 73 AND 76
 NO. 9—LOCATION (2)—MODELS BN 59, 78 AND 79

BODY BOLT TORQUE FOR ALL MODELS EXCEPT CONVERTIBLE . . . 15 TO 30 FT. LBS. CONVERTIBLE BODY BOLT TORQUE . . . 18 TO 30 FT. LBS.

NOTE: IF SHIMMING IS NECESSARY, USE ADDITIONAL SPACERS—8A-7011520 AND 8M-7001740

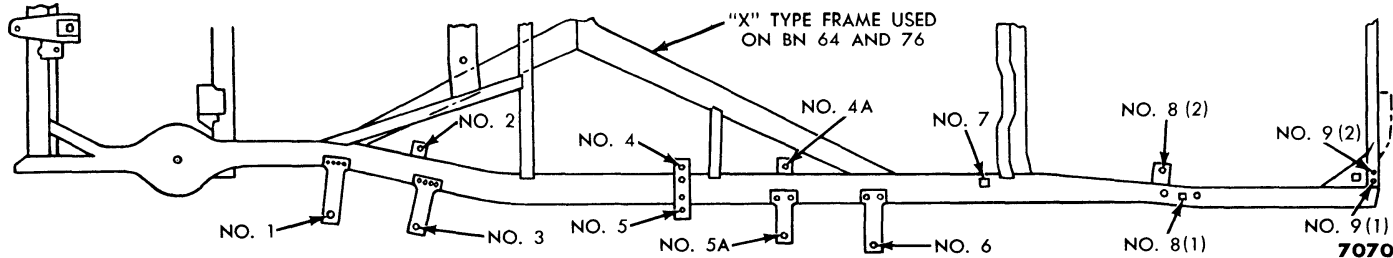

Fig. 5—Body Bolt Torque Specifications

original door was equipped with an arm rest, install the arm rest speed nuts in the inner door panel.

Install the lock assembly, the window regulator, the window and vent glass, and all other parts pertaining to these assemblies. Make all necessary connections and adjustments in these glass and hardware parts.

Adjust the door, the door hinges, and the striker plate for proper operation and fit (fig. 3). Install the cover plate at the upper hinge and the access plate at the bottom hinge. Attach the door check arm to the bracket with the rivet, and secure the rivet in place by peening (fig. 2).

Install the door trim panel, then install the remote control and window regulator handles and the arm rest. Install the garnish moulding spacers and garnish moulding. Install the push button locking knob.

Install the moulding clips, and snap on the outside mouldings.

(b) **REAR DOOR.** Install the two hinges in the center pillar. Position the door on the hinges, and attach it with bolts and flat washers at each hinge (fig. 4). If the original door was equipped with an arm rest, install the arm rest speed nuts in the inner door panel.

Install the lock assembly, the window regulator, the window and vent glass, and all other parts pertaining to these assemblies. Make all necessary connections and adjustments in these glass and hardware parts.

Adjust the door, the door hinges, and the striker plate for proper operation and fit (fig. 4). Install the hinge access hole covers.

Attach the door check arm to the bracket with the rivet and secure the rivet in place by peening (fig. 2). Install the center pillar trim panel.

Install the door trim panel, then install the remote control and window regulator handles and the arm rest. Install the garnish moulding spacers and garnish moulding. Install the push button locking knob.

Install the outside moulding clips, and snap-on the moulding.

b. Minor Door Alignment.

If the contour of the door does not require correction, the door can be aligned by the adjustments provided at the door hinges. The door hinges on all models are provided with elongated hinge holes at the pillar (front or rear doors) and enlarged holes on the door. The hinge bolts on the rear door are threaded into a floating tapping plate which permits circular hinge movement within the enlarged holes in the door. With this arrangement, the door can be shifted in any direction without bending the hinge.

Door alignment is also affected by the torque on the body mounting bolts. Occasionally, shifting the door at the hinges fails to correct misalignment entirely; such failure indicates that improperly tightened body bolts may have distorted the door openings rather than the door itself. When this problem occurs, adjust the door openings by tightening the body bolts to the torques specified in fig. 5, then align the doors to the new opening adjustment.

To correct door misalignment, it is usually necessary to shift the door. Make a visual inspection to determine in what direction the door must be shifted to fit properly in the opening and maintain the proper clearances around the door. The vertical clearance along the lock pillar must be $\frac{1}{8}$ - $\frac{3}{8}$ inch. Excessive clearance prevents the door weatherstrip from sealing properly and also prevents the lock rotor from properly engaging the striker plate. If the clearance is less than specified, the door may rub against the pillar.

After establishing the direction in which the door should be shifted, use the procedure below that applies.

(1) **SAGGED DOOR.** Sagged door conditions are usually corrected at the pillar on rear doors and at the

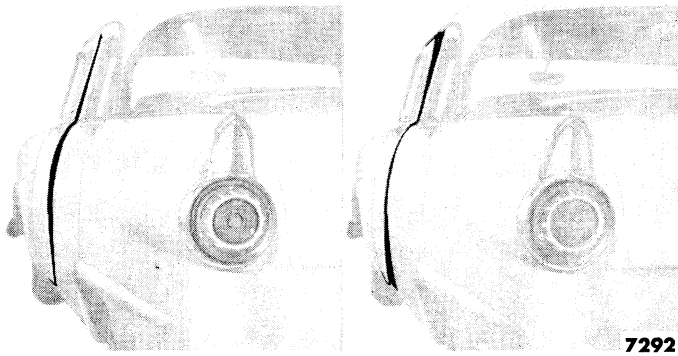
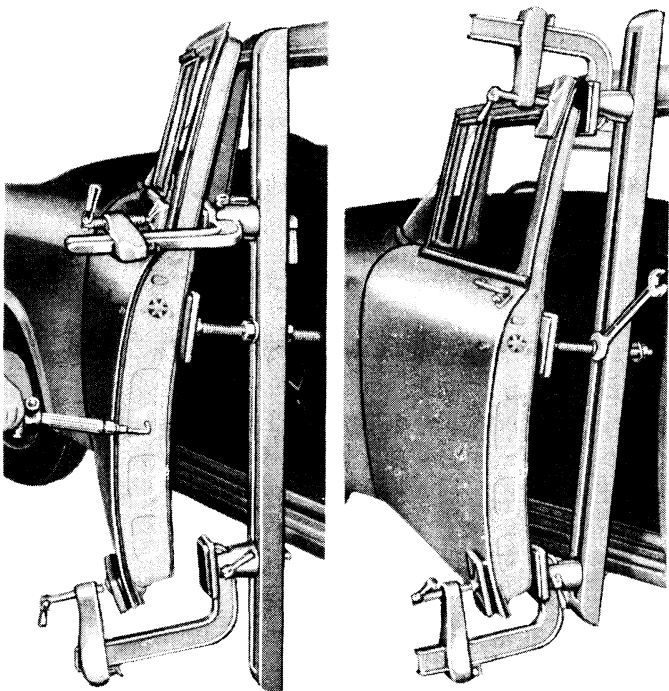

Fig. 6—Incorrect Door Contour

door on front doors. Remove the trim to gain access to the hinge bolts.

(a) **FRONT DOOR.** Loosen the hinge bolts on the door just enough to maintain a slight drag on the bolts (fig. 3). Do not loosen the hinge bolts at the pillar. Shift the door in the enlarged holes until the correct alignment is obtained.

When making this adjustment, make certain the door does not drop down in the door opening. Equal space at the top and bottom must be maintained. The correct clearance ($\frac{1}{8}$ to $\frac{3}{8}$ inch) must also be maintained along the lock pillar. Tighten the hinge bolts to 15 foot-pounds torque after the final adjustment is made. Check the door striker plate, and adjust it if necessary.



TOOL IN POSITION, READY TO PULL DOOR INWARD AT BOTTOM.

TOOL IN POSITION, READY TO PULL DOOR INWARD AT TOP.

7048

Fig. 7—Typical Door Bending Tool

(b) **REAR DOOR.** Loosen the hinge bolts on the center pillar just enough to maintain a slight drag on the bolts (fig. 4). Do not loosen the hinge bolts on the door. Shift the door in the elongated holes, either at the upper or lower hinge, until the door is in correct alignment. Make certain that a clearance of $\frac{1}{8}$ - $\frac{3}{8}$ inch is maintained along the lock pillar. Tighten the hinge bolts to 15 foot-pounds torque after the adjustment is made. Check the door striker plate, and adjust it if necessary.

(2) **DOOR OUT AT BOTTOM OR TOP.** If the door is not bent or twisted out of shape, adjustment can be made at the door hinge.

(a) **FRONT DOOR.** Loosen the upper or lower hinge bolts at the pillar (fig. 3). Do not loosen the hinge bolts completely. There should be just enough drag on the bolts to hold the door in place. Move the door in the elongated hinge holes, either away from or toward the body, until the proper alignment is obtained. Tighten the hinge bolts to 15 foot-pounds torque. Adjust the door striker plate after door alignment is completed.

(b) **REAR DOOR.** Loosen the upper or lower hinge bolts at the door (fig. 4) just enough to maintain a slight drag on the bolts to hold the door in place. Move the door in the enlarged holes, either away from or toward the body, until proper alignment is obtained.

Tighten the hinge bolts to 15 foot-pounds torque. Adjust the door striker plate after door alignment is completed.

c. Major Door Alignment.

If the door is twisted or bent out of shape and hinge adjustments will not correct the condition, it will be necessary to change the contour of the door to fit the body.

First determine what part of the door requires straightening, the upper, lower, or center portion (fig. 6). To do this type of repair, it is advisable to use tools which are designed specifically for this type of work. Figure 7 shows the proper method of mounting the bars and clamps of a typical door bending tool to accomplish the bend or twist for proper door contour.

If excessive bending is required to change the contour below the door belt line, apply heat as shown in fig. 7. If heat is required, remove all weatherstripping, the door trim panel, and the glass from the door. To localize the heat, apply asbestos paste around the area where the heat is to be applied.

To bend or twist the door in the opposite direction to that shown in the illustrations, reverse the bars so that pressure is applied to the outer side of the door instead of the inner side.

2. DOOR LOCKING MECHANISM

The locking mechanism consists of the door lock, lock cylinder, inside and outside handles, striker plate, and the linkage connecting these units. In order to assure proper operation, all of these units must be considered when service operations are performed. As an example, a door lock will not function properly if the remote control linkage or outside door handle is out of adjustment. Door misalignment is also a direct cause for lock failure. Doors that are not properly aligned will place excessive strain on the engaging parts of the lock and striker plate, and cause premature wear. The repair and adjustment procedures for all parts related to the locking mechanism are given here.

a. Lubrication.

The locking mechanism must have lubricant to function properly. It is important that all moving parts be lubricated when service operations are performed. This not only applies to the specific units being replaced or repaired, but also to the related units. Use B4A-19587-A or its equivalent to lubricate the locking mechanism. Use lock fluid 1A-19587-A on the lock cylinders.

b. Outside Door Handle.

(1) **REPLACEMENT.** Remove the door trim panel. Working through the access hole provided on the door inner panel, remove the screw from the outside door handle (fig. 8). Remove the screw located at the face of the door just above the door lock, then remove the door handle.

Before installing the handle, check, and if necessary, adjust the clearance between the handle release pin and the face of the lock release lever as outlined below.

To install, position the rubber pads and handle on the door. Install and tighten the screw at the face of the door. Working through the access hole in the door inner panel, install the screw at the other end of the handle. Install the trim panel and hardware.

(2) **ADJUSTMENT.** The outside door handle is provided with an adjustment to maintain the correct clearance between the face of the door lock release lever and the release pin on the door handle (fig. 8).

To make this adjustment, remove the outside door handle. Loosen the lock nut at the release pin, and either lengthen or shorten the release pin until the required length is obtained ("A" fig. 8).

Door handle release pin length settings are one inch for the front door and $\frac{5}{16}$ inch for rear doors. This will give a clearance of $\frac{1}{32}$ – $\frac{1}{16}$ inch between the release pin and the door lock release lever when the handle is installed ("B" fig. 8).

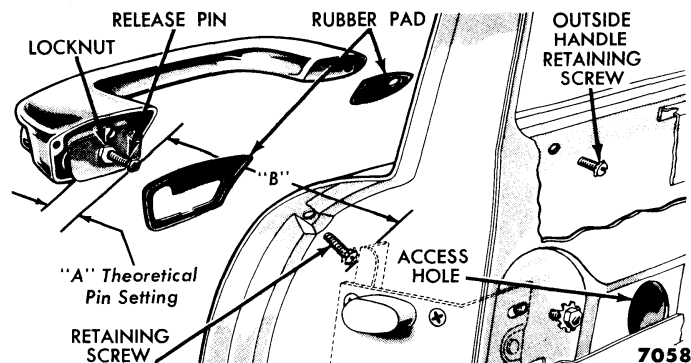

Fig. 8—Outside Door Handle

Tighten the lock-nut finger tight plus an additional $\frac{1}{3}$ turn with a wrench.

c. Striker Plate.

The striker, the door lock rotor, and the auxiliary plate are arranged in such a way as to decrease the possibility of the door being separated from the lock pillar either in a lateral or in a forward or backward direction (fig. 9). When the door swings to closed position, the rotor passes behind the auxiliary plate and engages with the striker. This engagement of the rotor teeth decreases the possibility of the door swinging open (separation from the lock pillar in a lateral direction). The auxiliary plate, on the outer surface of the striker plate, decreases the possibility of the rotor sliding forward and out of engagement with the striker (separation from the lock pillar in a forward or backward direction) (fig. 9).

The striker plate retaining screws are threaded into a

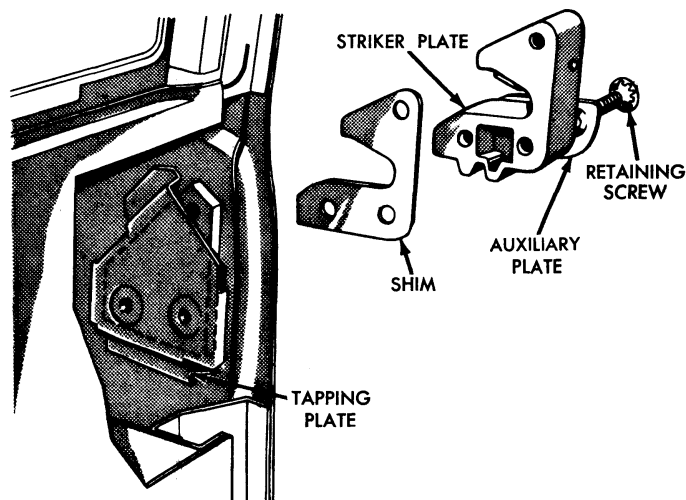

Fig. 9—Striker Plate and Lock Assembly

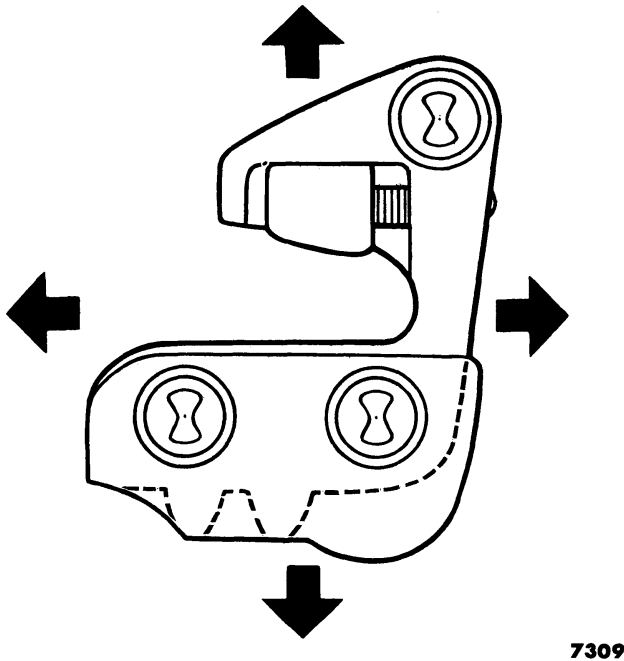

Fig. 10—Striker Plate Adjustments

floating tapping plate. The holes in the pillar face are enlarged to permit in and out, as well as up and down movement (figs. 10 and 11).

(1) **ADJUSTING “UP” AND “DOWN” MOVEMENT.** This adjustment is provided to permit alignment with the door lock and to prevent up and down movement of the door when it is closed. This is only a minor adjustment, and is not intended to correct a

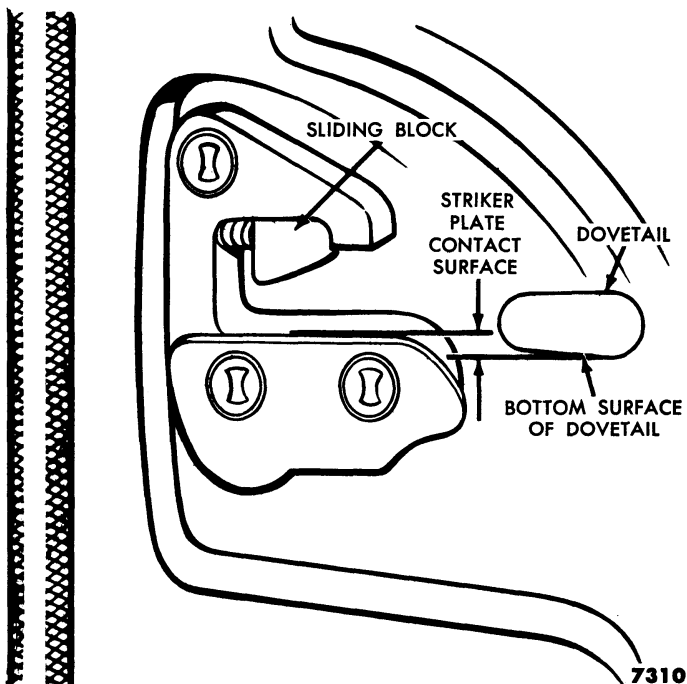

Fig. 11—Relationship of Striker to Dovetail

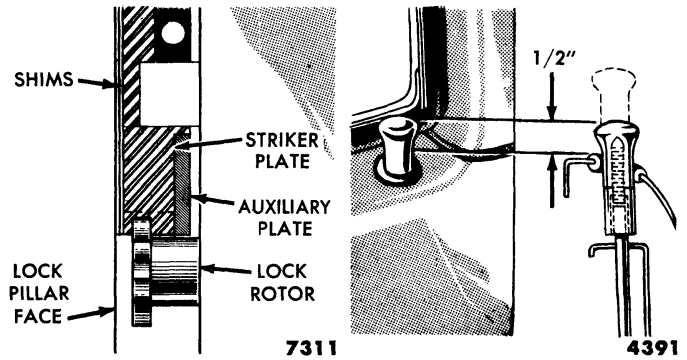

Fig. 12—Striker Plate to Rotor Adjustment

Fig. 13—Door Inside Locking Button Adjustment

door with excessive sag. If the door has a noticeable sag when opened, the door must be aligned to avoid excessive strain on the dovetail and the contact surface of the striker. Failure to align the door properly will cause premature wear on the striker plate.

After first determining that the door is properly aligned, position the striker plate so that the contact surface (fig. 11) is parallel with the bottom surface of the dovetail on the lock. As the dovetail begins to engage the striker plate when closing the door, the bottom surface of the dovetail should not be more than $\frac{1}{32}$ inch below the contact surface of the striker (fig. 11). As the door closing is completed, the dovetail will climb up on the striker so that its lower surface will rest evenly on the contact surface of the striker plate.

NOTE: *If the sliding block requires replacement, replace the complete striker plate assembly, as the sliding block is not serviced separately.*

(2) **ADJUSTING “IN” AND “OUT” MOVEMENT.** Scribe a pencil line along the top of the striker plate for a reference line to maintain the “UP” or “DOWN” adjustment (fig. 10). Loosen the striker plate retaining screws. Position the striker plate (either inward or outward) so that the door will close with a normal swing, and the plate will hold the door tight enough to prevent the door from rattling when it is closed. Tighten the screws securely.

(3) **ADJUSTING ROTOR TO STRIKER PLATE.** For proper latching operation, the rotor should engage the striker plate with equal clearance on each side in order to avoid interference with the auxiliary plate or with the face of the lock pillar (fig. 12). To center the lock rotor between the auxiliary plate and the lock pillar face, add or remove shims back of the striker plate (fig. 12). If the rotor is too close to the lock pillar face after all shims have been removed, shift the door away from the lock pillar by adjusting the door hinges.

d. Door Inside Locking Button and Control Rod.

To assure positive locking action, the proper height of the locking button must be maintained. The correct height is $\frac{1}{2}$ inch measured from the inside finish strip to the top of the locking button (fig. 13). The locking button is threaded on the vertical control rod. To lengthen the stroke, turn the locking button counter-clockwise. If the button slips on the control rod, replace the locking button. Do not hammer on the locking button.

If the locking button is excessively loose or rattles against the inside finish strip, check to make certain the rubber grommet is properly installed (fig. 13).

The rear door control button operates the door lock through a bell crank which operates a horizontal rod connected to the door lock (fig. 14). To assure free operation, lubricate the bell crank and the anti-rattle that covers the horizontal rod.

(1) **REMOVAL.** Remove the door trim panel. Remove the inside locking button. On front doors, the lock assembly must be removed in order to disconnect the push button control rod (fig. 16). On rear doors, remove the cap screw at the bell crank. Bend the two clips off the horizontal rod, and disconnect the vertical and horizontal control rods from the bell crank (fig. 14).

(2) **INSTALLATION.** To install the control rod at the front door, first fasten the control rod to the lock assembly, then install the lock assembly (fig. 16).

To install the control rods at the rear door, fasten both rods to the bell crank (fig. 14). Fasten the horizontal rod to the door lock. Install the bell crank retaining screw. Bend the retaining clips over the horizontal rod. Install the door trim panel and hardware.

e. Door Lock Cylinder Replacement.

When replacing a door lock cylinder, it is recommended that a complete set of lock cylinders be installed. The set includes the ignition switch as well as lock cylinders for both front doors. This will avoid carrying an extra key when only one lock cylinder is replaced. It is not possible to adapt the old key to fit the replacement lock.

The key code number is stamped on the shaft of the right hand door lock cylinder. If new or duplicate keys are required and the key code number is unknown, the lock cylinder must be removed to obtain the code number.

The lock cylinder is secured in the door with a horseshoe type retainer which is located under the door weatherstrip. To replace the lock cylinder, move the weatherstrip to one side to expose the retainer. Pull

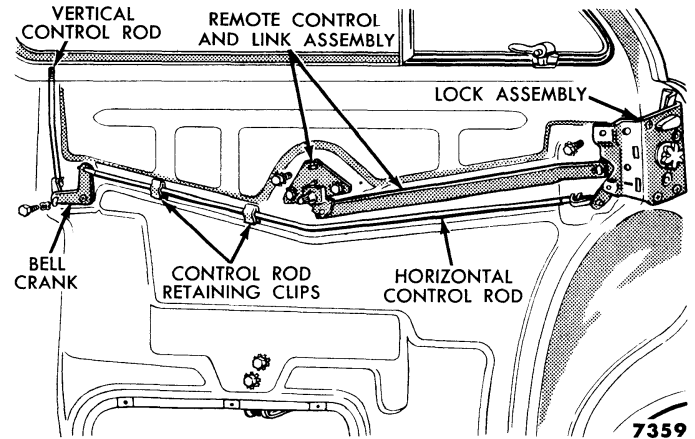

Fig. 14—Rear Door Locking Controls

the retainer out with a pair of pliers (fig. 15). Remove the lock cylinder from the door. Remove the rubber gasket from the station wagon lock cylinder.

Lubricate the lock cylinder with Lock Fluid (1A-19587-A).

To install, turn the key to the unlocked position in the cylinder. Insert the lock cylinder into the door. As the cylinder is inserted, guide the cylinder shaft and actuating lever into the door lock. Install the lock cylinder retainer.

f. Door Inside Handle Remote Control Linkage.

The following information applies to both front and rear doors.

(1) **ADJUSTMENT.** The remote control linkage must be adjusted for a maximum free travel of $\frac{1}{16}$ inch

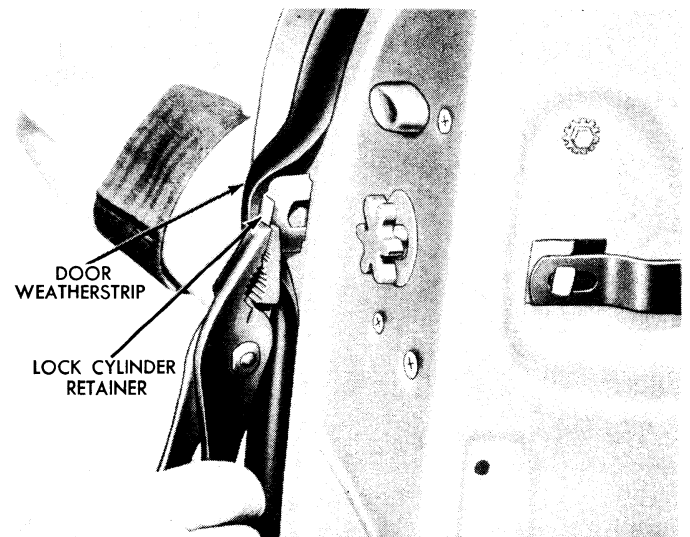

Fig. 15—Door Lock Cylinder Replacement

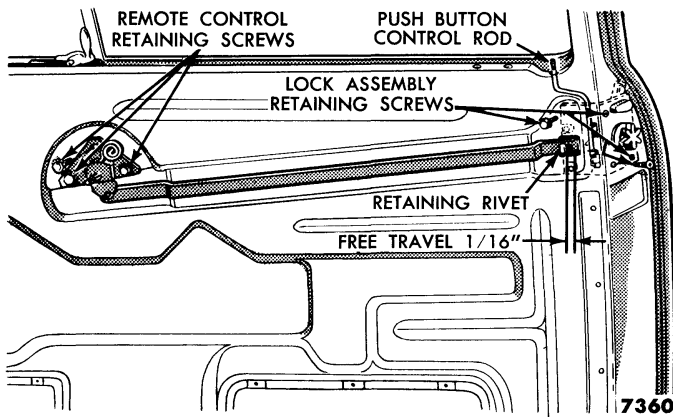

Fig. 16—Front Door Locking Controls

between the retaining rivet and the slot in the remote control link (figs. 14 and 16). Elongated holes are provided in the remote control assembly mounting bracket to make this adjustment. Loosen the retaining screws at the mounting bracket, and shift the bracket until the proper free travel is obtained. Tighten the screws securely after making the adjustment.

(2) **REPLACEMENT.** Remove the door trim panel. Remove the remote control retaining screws (fig. 16). Swing the remote control link downward to disengage it from the retaining rivet on the lock assembly.

To install, hook the remote control link to the lock assembly. Swing the remote control link and mounting into position and install the retaining screws. Before tightening the screws, adjust the link free travel as outlined above. Tighten the screws securely. Install the trim panel.

g. Door Lock Replacement.

It is necessary to remove the door trim panel and garnish moulding before removing the lock assembly from either the front or rear door. Before installing either lock assembly, lubricate all moving parts with lubricant (B-4A-19587-A) or its equivalent. After lock replacement, install the door trim panel, garnish moulding and hardware. Separate replacement procedures for the front and rear door lock assemblies are given here.

(1) **FRONT DOOR.** Remove the inside handle remote control linkage retaining screws, swing the link down and disengage it from the retaining rivet on the

lock assembly. Remove the door lock cylinder. Remove the plastic sheet from the door inner panel.

NOTE: Lock removal does not require removal of the glass. In order to make clearance for removal of the lock assembly, the lock side glass run assembly should be disconnected from the door face.

A tab at the upper end of the lock side glass run assembly hooks into a bracket on the door face. The lower end of the assembly is attached to the lower bracket with a screw. Remove this screw, then, in order to release the tab from the bracket at the upper end, it will be necessary to release the glass run retaining clips along the top and side of the window. Lower the glass, release the upper glass run retaining clips, lift the lock side glass run up to unhook it from the bracket, then raise the glass far enough to clear the lock assembly. Remove the lock retaining screws (fig. 16). Move the glass run to one side to provide clearance, then lower the lock assembly out of the door.

Install the replacement lock assembly through the access hole and secure it in place with the retaining screws.

Tighten the three retaining screws at the face of the lock before tightening the one screw at the inner panel (fig. 16). This will assure proper lock alignment.

Hook the tab of the lockside glass run in the bracket, and install the retaining screw at the lower end of the glass run. Lower the window and install the upper glass run. Connect the remote control linkage to the lock assembly, swing the remote control assembly into place, and install the three retaining screws. Adjust the linkage free play. Install the plastic sheet on the door panel. Install the door lock cylinder.

(2) **REAR DOOR.** Remove the control rod assembly and the inside handle remote control linkage (fig. 14). Remove the plastic sheet from the inner door panel. Remove the lock assembly retaining screws and withdraw the lock assembly from the access hole.

Install the lock assembly through the upper access hole and secure it in place with the retaining screws. Tighten the three screws at the face of the lock before tightening the one screw at the inner panel. This will assure proper lock alignment (fig. 14). Install the inside handle remote control linkage and adjust free play. Install the control rod assembly and the plastic sheet.

3. LUGGAGE COMPARTMENT DOOR REPLACEMENT AND ALIGNMENT

The replacement procedures, and other procedures associated with replacement of the luggage compartment door, are given in this section. Since the replacement door is delivered as a sheet metal shell, all usable hardware parts should be transferred from the original door to the replacement door.

Alignment is an important part of the replacement procedure. Two types of alignment (minor and major) are considered in this section.

A minor alignment is made by adjustments at the hinges. A major alignment requires changing the contour of the door to fit the opening.

a. Removal.

Disconnect the upper link of the lock actuating lever from the lock cylinder bell crank, and remove the lock assembly and the lock cylinder and sleeve assembly. Remove the handle and ornamentation. Remove the luggage compartment light, if so equipped, from the inner door panel. Remove the bolts that secure the luggage compartment door to its hinges, and lift the door from the vehicle (fig. 17).

If either hinge is damaged, remove the bolts from the hinge support bracket, and remove the hinge and spring as an assembly. Before the right hinge can be removed, the spare tire must be removed.

To replace the spring without removing the hinge, disconnect the spring from the lower end of the hinge, then disconnect it from the upper end of the hinge. When installing the spring, connect the upper end first.

b. Installation.

Spray the luggage compartment replacement door and hinge with paint that matches the color of the vehicle. Apply rubber cement to the replacement door flange and to the weatherstrip. Install the weatherstrip to the door.

Install the hinges on the support brackets, then install the attaching bolts (fig. 17). Mount the door on the hinges, and secure it with two attaching bolts at each hinge. Install the lock and lock cylinder assemblies, and connect the lock actuating lever. Install the handle and ornamentation. Align the door to fit the opening, and adjust the striker plate to the lock assembly. Install the luggage compartment light to the inner door panel if so equipped.

c. Check Fit of Luggage Compartment Door.

To determine if adjustment is necessary, coat the edge of the body flange with white chalk, then close the deck lid to transfer the chalk mark onto the weatherstrip. If the chalk mark is visible around the entire weatherstrip, the deck lid is sealing properly. If the chalk mark is not visible or is spotty, adjustment is necessary. Before making adjustments, first determine what type of adjustment is necessary. If the contour of the deck lid does not require correction, perform a minor alignment. If the contour of the deck lid needs correction, a major alignment is required.

d. Minor Alignment.

Minor alignment is accomplished by shifting the lug-

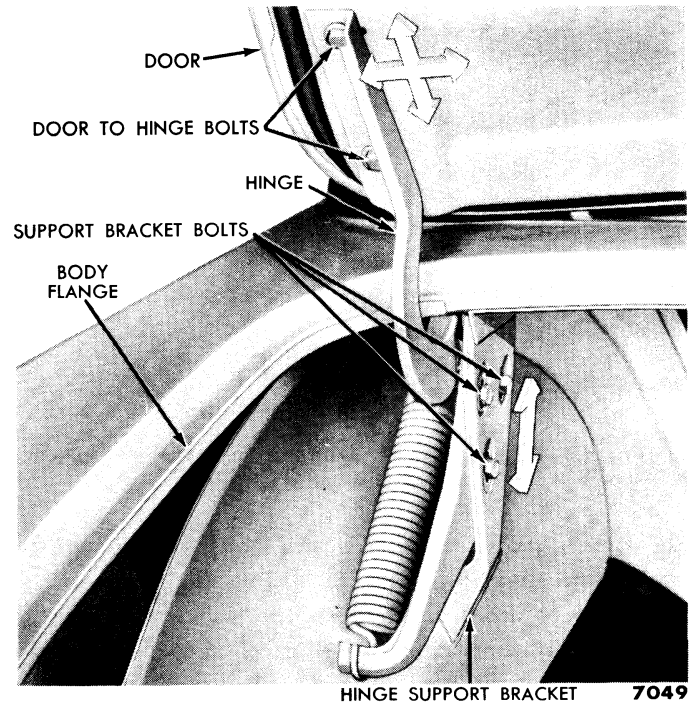

Fig. 17—Luggage Compartment Door

gage compartment door hinges in the elongated bolt holes at both ends of the hinges. Horizontal adjustment is made at the door to hinge bolts; vertical adjustment is made at the support bracket bolts (fig. 17). After any adjustment of the luggage compartment door, the striker plate adjustment should be checked.

(1) **HORIZONTAL.** Each of the door to hinge bolts goes through an elongated hole in both the hinge and the inner door panel, and threads into a floating tapping plate located between the inner and outer door panels (fig. 17). The bolt hole in the hinge is elongated for forward and backward movement; the hole in the door panel is elongated for side to side movement.

If the space between the door and its opening is unequal along the sides, top, or bottom, loosen the door to hinge bolts on both sides (fig. 17). Move the luggage compartment door forward or backward or from side to side, until it fits properly in the opening, then tighten the bolts.

(2) **VERTICAL.** Each luggage compartment door hinge is fastened to the hinge support bracket by three bolts. The bolt holes are elongated for up and down movement (fig. 17). Loosen the three bolts on each side, then raise the door to make it flush with the body, or lower it so it will press more firmly against the weatherstrip.

e. Striker Plate Adjustment.

The luggage compartment door must be properly aligned before the striker plate is adjusted. To adjust

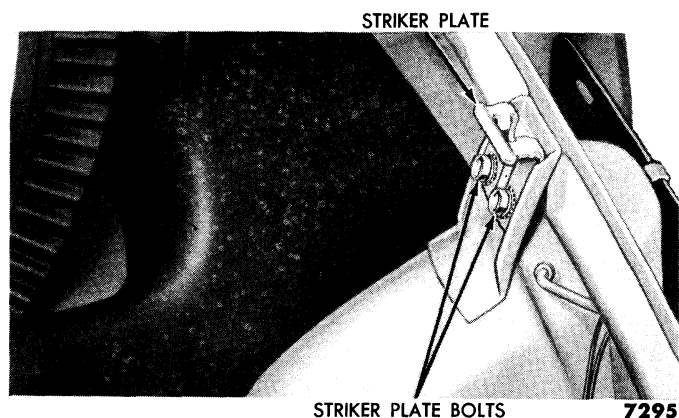

Fig. 18—Luggage Compartment Door Striker Plate Adjustment

the striker plate, loosen the two bolts just enough to maintain a slight drag (fig. 18). Move the striker plate, either up or down, until the proper locking position is obtained. When correctly adjusted, the door should lock under slight hand pressure. Tighten the bolts to secure the adjustment. If this procedure fails to adjust the striker plate, follow the instructions given in Section 4, Par. e.

f. Major Alignment.

Usually adjustments at the hinges will correct slight misalignment; however, if the luggage compartment door is twisted out of shape or does not follow the contour of the body, it will be necessary to correct the door contour to fit the body. If the door is seriously buckled, it must be removed and straightened on a fixture or replaced.

(1) **TWISTED DOOR.** If the door is twisted and does not seat properly on one side, place a rubber mallet between the door and the extension panel at the opposite side. Close the door against the mallet and apply pressure at the side that does not seat properly

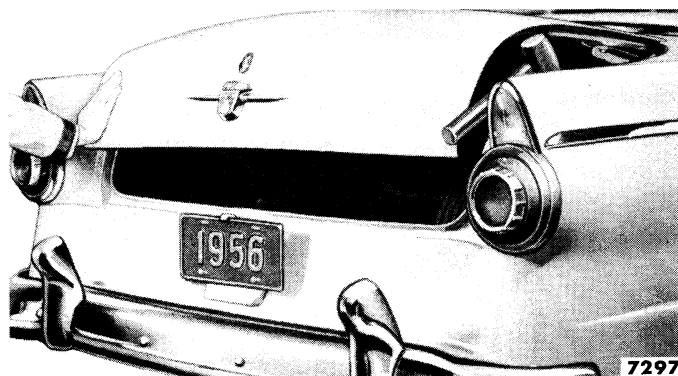

Fig. 19—Correcting Twist in Luggage Compartment Door

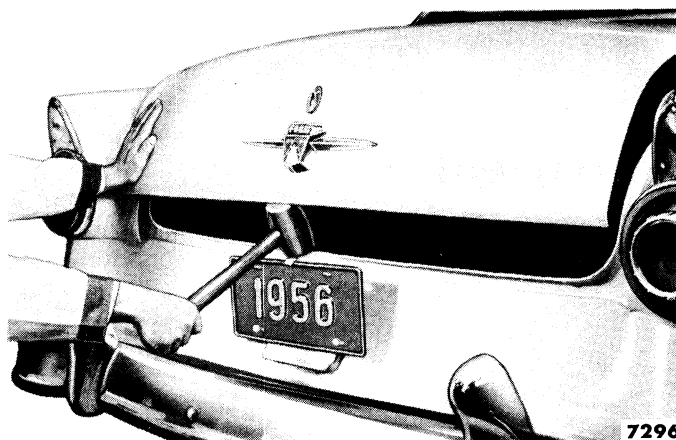

Fig. 20—Fitting Lower Corner of Door to Lower Panel.

(fig. 19). Do not apply excessive pressure. Check the door, and if necessary, repeat the above procedure.

(2) **DOOR DOES NOT FIT CONTOUR ALONG EXTENSION PANEL.** First determine where the door does not fit properly against the drain gutter. At points where the drain gutter is high, carefully strike the top surface of the extension panel (quarter panel) with a rubber mallet. Make sure that the blows are directed close to the drain gutter with the flat face of the mallet.

At points where the drain gutter is low, direct the mallet blows against the underside of the extension panel. In extreme cases, it may be necessary to raise the extension panel with a power jack.

(3) **DOOR DOES NOT FIT ALONG THE LOWER BACK PANEL.** First determine where the door does not fit along the lower back panel. Place a piece of paper between the door and lower back panel. Close the door, then withdraw the paper. If the door is sealing properly a slight drag will be noticed when the paper is withdrawn. Make this same check at both ends of the door and at the center, next to the striker plate. If no contact is obtained along the bottom, adjust the striker plate.

If the door contacts at both ends and not at the center, use a rubber mallet and carefully strike the inner side of the lower back panel to move the back panel out toward the door.

If the door is tight at the center and no contact is obtained at either or both lower corners, two methods can be used to make the correction. First, hold the door part way open, and with a rubber mallet, strike the corner of the door that is not making contact. The other method is to place the mallet between the door and lower panel at approximately the center, then apply pressure at the ends of the door (fig. 20).

4. LUGGAGE COMPARTMENT DOOR LOCKING MECHANISM AND HANDLE

The following paragraphs outline the replacement procedures for the door handle, lock cylinder sleeve, lock cylinder, and lock assembly. All of these items are serviced as separate assemblies. When the lock assembly is replaced, the striker plate adjustment should be checked.

a. Door Handle Replacement.

Open the door and work through the access holes in the inner panel (fig. 21). Remove the four stud nuts and washers, then withdraw the handle from the outer side of the panel (fig. 22).

To install, position the handle to the outer side of the panel so that the four studs will enter the four holes. Open the door and install the washers and stud nuts through the four recess holes in the inner panel (fig. 21).

b. Replacement of Lock Cylinder and Sleeve Assembly.

To remove the assembly, open the door and work through the access holes in the inner panel (fig. 21). Remove the "push-on" nut from the bell crank, and disconnect the lock actuating lever link from the bell crank. Remove the large hex nut, flat washer, and spacer from the lock cylinder sleeve. Remove the cylinder and sleeve assembly from the outer side of the door panel.

Before installing the assembly, slide the rubber pad over the sleeve. Insert the cylinder, from the outside, into the top hole in the panel (fig. 22). Then working through the access hole in the inner panel, secure the assembly to the door by installing the spacer, flat washer, and hex nut on the cylinder sleeve (fig. 21).

"PUSH-ON" NUT SPACER LOCK CYLINDER BELL CRANK HEX NUT

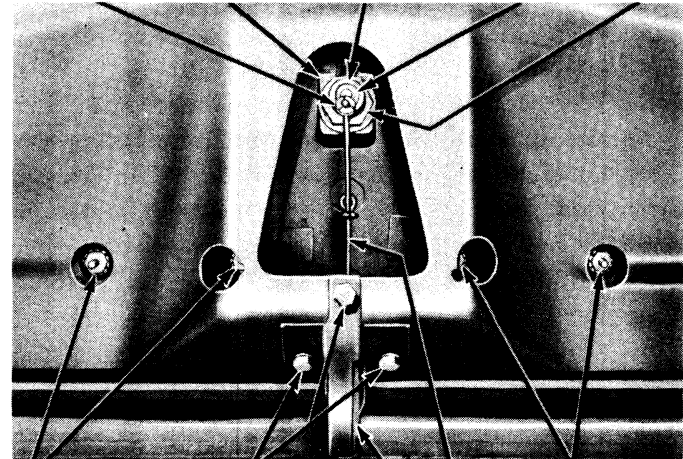

ATTACHING SCREWS DOOR HANDLE STUDS
LOCK ASSEMBLY DOOR HANDLE STUDS
LOCK ACTUATING LEVER LINK 7299

Fig. 21—Handle and Locking Mechanism Replacement

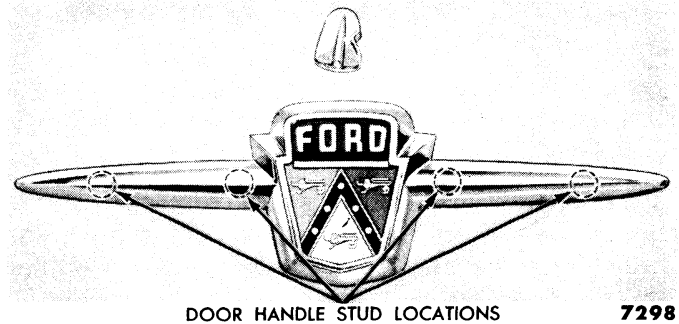

DOOR HANDLE STUD LOCATIONS

7298

Fig. 22—Luggage Compartment Door Handle

Connect the lock actuating lever link to the bell crank, and secure it with the "push-on" nut.

c. Removal of Lock Cylinder from Sleeve.

First, remove the cylinder and sleeve assembly from the door. Insert the key into the lock cylinder, then turn the key one-quarter turn clockwise. With the key in this position, press the release pin down with a piece of wire to release the lock cylinder from the sleeve (fig. 23). Remove the cylinder from the sleeve.

Before installing the lock cylinder lubricate it with Lock Fluid (1A-19587-A). Insert the key in the lock, and turn it 1/4 turn clockwise. Press the release pin down, and insert the cylinder into the sleeve (fig. 23). Turn the key to the vertical position, then remove the key.

d. Luggage Compartment Door Lock Replacement.

To replace the lock assembly, remove the "push-on" nut from the bell crank (fig. 21), and disconnect the lock actuating link. Remove the three screws and washers that secure the lock assembly to the inner door panel, and remove the lock and the two actuating lever links from the door (fig. 21).

To install, position the lock assembly at the underside of the door panel. As the lock is being installed, allow

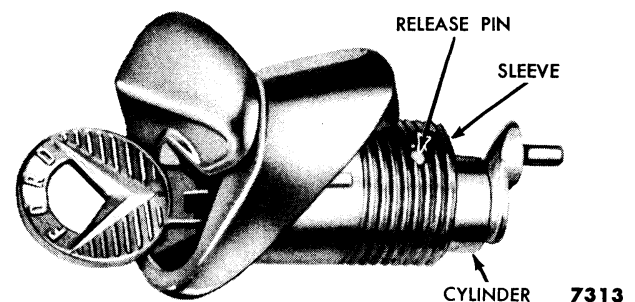

Fig. 23—Removal of Lock Cylinder from Sleeve

the actuating lever links to enter the access hole first. Secure the lock to the panel with the three attaching screws (fig. 21), and connect the lock actuating lever link to the bell crank with the "push-on" nut.

e. Luggage Compartment Door Lock Adjustment.

If excessive key pressure is required to unlock the door or if the door does not release, the striker plate is misaligned with relation to the lock assembly on the deck lid. Open the door and check the alignment of the lock rotor with relation to the striker plate. The striker plate should enter the lock rotor without rubbing against the forward or rear edges of the rotor housing.

5. GRILLE AND HOOD

This section applies to all models except the Thunderbird which is covered separately in Section 7.

a. Grille Replacement.

The radiator grille assembly consists of two grille bars, a center joint cover and three grille bar supports. The top outer edge of each grille bar is attached to the fender by three bolts and spring nuts, and the upper flange of each grille bar is attached to the hood lock support panel by four bolts and spring nuts. See the light arrows in fig. 24.

Two bolt flanges are provided on the lower side of the grille bar. The outer bolt flange is attached to the

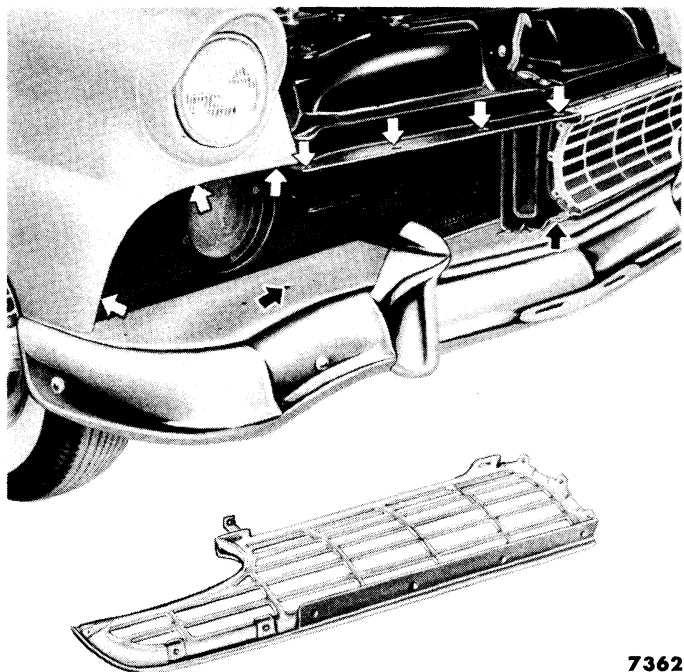

Fig. 24—Radiator Grille Replacement

If alignment is required, first determine the direction the lock or striker plate should be moved. To move the lock assembly forward, add $\frac{1}{4}$ inch spacer washers between the door inner panel and the two rear retaining screws of the lock (fig. 21). This will tilt the lock assembly inward.

If the striker plate does not have sufficient clearance at the rear surface of the lock assembly, add $\frac{5}{16}$ inch spacer washers between the striker plate and the lower back panel (fig. 18).

If there is any interference between the lower actuating link and the door where the link enters the inner panel opening, close the hook end of the actuating link slightly to provide clearance in the inner panel opening. Use pliers to bend the link.

outer support bracket which mounts to the stone shield, and the lower bolt flange mounts to a flange on the center support. See the dark arrows in fig. 24.

The inner end of each grille bar is provided with three bolt flanges which enable the two grille bars to be fastened together by three bolts and nuts.

On all models, both grille bars can be removed as an assembly and then disassembled off the car. First remove both parking light housings in order to gain access to the three bolts that attach the top outer edge of each grille bar to the fender. Remove these three bolts at each fender. Remove the eight bolts that attach the grille assembly to the hood lock support panel. From underneath the stone shield, remove the nut from the bolt that attaches each outer support to the stone shield. Remove the bolts, nuts and washers that attach the lower grille bar flanges to the flanges on the center support. Remove the two grille bars and outer support brackets as one assembly.

With the grille assembly off the car, the two grille bars can be separated. Remove the two nuts that retain the center joint cover, then remove the bolts, nuts, and "C" washers at the three inner bolt flanges.

To assemble, join the bars together by installing the bolts, nuts, and "C" washers at the three bolt flanges, then install the joint cover and secure it with two retaining nuts. If the grille is being replaced, transfer the small outer support brackets to the replacement assembly.

To install, position the grille assembly so that: the flange along the top of the grille bars fits over the lock support panel; the outer support bracket bolts enter their respective holes in the stone shield; and the lower bolt flanges slide under their respective flanges on the center support. If these attaching points do not match,

7362

improper clearance between the two grille bars is probable. In such an event, change the number of "C" washers between the grille bars at the three bolt flanges. Use whatever number of "C" washers are necessary for a correct fit. After the assembly is properly positioned, install all the attaching bolts, nuts, and washers. Install the parking light assemblies and connect the wires.

On 8-cylinder cars that are not equipped with the Select Aire Conditioner, the grille bars can be serviced individually as shown in fig. 24.

b. Hood Replacement.

Remove the mounting bolts and hood lock dowel assembly from the underside of the hood (fig. 31). Remove the attaching nuts from under the hood, and lift the hood ornament and emblem with backing pad from the top of the hood. Open the hood and have an assistant support the hood while the hinge bolts are being removed. Protect the cowl and fenders with covers. Remove the bolts that attach the hood to the hinges, then carefully remove the hood (fig. 25).

Spray the replacement hood with paint that matches the color of the car. Install the hood lock dowel assembly with four bolts and nuts. Install the top ornament and hood emblem with backing pad, and secure them with nuts from under the hood.

Before installing the hood, place a protective pad at each corner of the fender to prevent damaging the paint. Position the hood on the hinges, and while supporting it in the open position, install the bolts that attach the hood to the hinges (fig. 25). Align the hood, and adjust the lock and dowel mechanism for proper locking operation.

c. Hinge and Spring.

To replace the hinge, remove the hood, then remove the nuts and washers, from the hinge to cowl studs (fig. 26). The two rear nuts are removed from inside the vehicle underneath the dash panel. Remove the hinge assembly from the cowl side panel.

To remove the hinge spring, remove the hinge assembly from the vehicle. Place the hinge bracket in a vise, disconnect the lower end of the spring with pliers, then unhook the upper end.

To install, hook the upper end of the spring to the hinge bracket, pull the lower end downward with pliers, and connect it to the lower end of the hinge bracket. Position the hinge assembly so that the four studs will enter the holes in the cowl side panel, and secure it with nuts and washers (fig. 26).

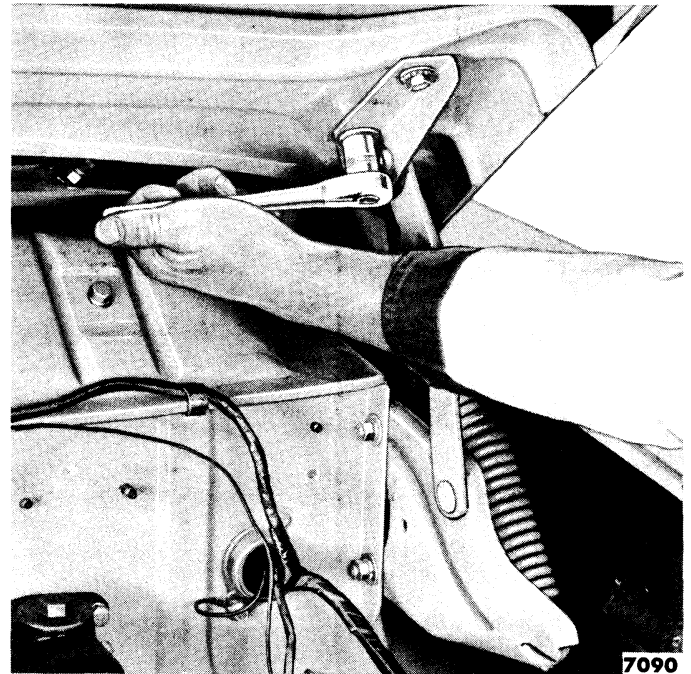

Fig. 25—Hood Removal and Installation

The spring can also be removed without removing the hinge from the car, but care must be taken to avoid injury. With this procedure, hood removal is unnecessary. Just remove the hinge to hood bolts. Disconnect the lower end of the spring with pliers, then unhook the upper end.

To install, connect the upper end of the spring to the hinge bracket, and pull the lower end downward with pliers. While holding the spring in its extended position, pry its lower coil over the flange on the hinge bracket with a screw driver, and at the same time connect the spring to the lower end of the hinge bracket. Install the hinge to hood bolts.

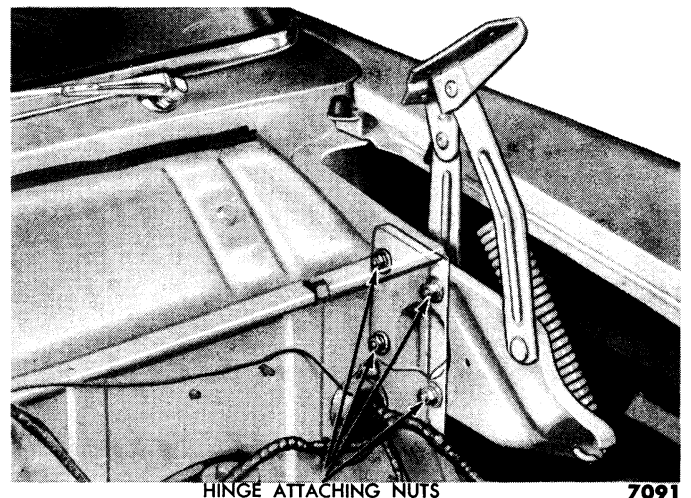

Fig. 26—Hood Hinge Replacement

6. HOOD ALIGNMENT AND LOCK ADJUSTMENT

Hood adjustments are provided at the hood hinge brackets and at the adjustable rubber bumpers on the front of the hood. Most hood adjustments require a corresponding adjustment of either the hood lock dowel or the locking plate assembly.

Elongated holes in the hinge to hood brackets permit the hood to be shifted forward or backward (fig. 28). If both sides of the hood are shifted equally in the same direction, either a forward or backward change in position will result. However, if one side is shifted forward

and the other side is shifted backward, a lateral change in hood position will result. Such horizontal shifts in hood position require corresponding shifts in the locking plate assembly.

The hood locking plate assembly can be shifted horizontally (fig. 30). This shift is made possible by elongated bolt holes in the support panel, which permit forward and backward movement, and by elongated bolt holes in the locking plate assembly, which permit lateral movement.

Elongated holes in the cowl side panels permit the rear end of the hood to be raised or lowered (fig. 28). This hood adjustment requires no corresponding adjustment of the locking plate assembly or dowel.

The front end of the hood can be raised or lowered by shortening or lengthening the adjustable rubber bumpers at the front of the hood on either side (fig. 29). If the bumpers are adjusted, the lock dowel must be correspondingly lengthened or shortened for proper lock operation (fig. 31). Since the dowel is threaded and is provided with a slot, it can be turned in or out with a screwdriver.

The sketches shown in fig. 27 illustrate the types of hood misalignment that can usually be corrected at the hinges, rubber bumpers, and dowel assembly. Correction procedures for each of the misalignments shown in fig. 27 are given below.

a. Hood Shifted to One Side at Front.

If the hood is shifted to one side at the front (fig. 27), loosen the hinge adjusting screws at the side that has the excessive space (fig. 28). In extreme cases, it may be necessary to loosen the adjusting screws on both sides. Grasp the front of the hood and shift it toward the side that has the excessive clearance, until the hood is centered between the fenders. Tighten the hood adjusting screws. After final hood adjustment, adjust the locking plate assembly to match the new hood position.

b. Excessive Space Along Rear.

If the hood has excessive space between the rear edge of the hood and the cowl top panel (fig. 27), loosen the hinge-to-hood adjusting screws on both sides. Move the hood toward the rear in the elongated holes at the hinges. Tighten the screws at each hinge, then adjust the locking plate assembly to match the new hood position.

c. Hood High at Rear.

If the top surface of the hood, along the rear edge, is higher than the cowl top panel (fig. 27), loosen the nuts on the adjusting bolts that attach the hinge brackets to

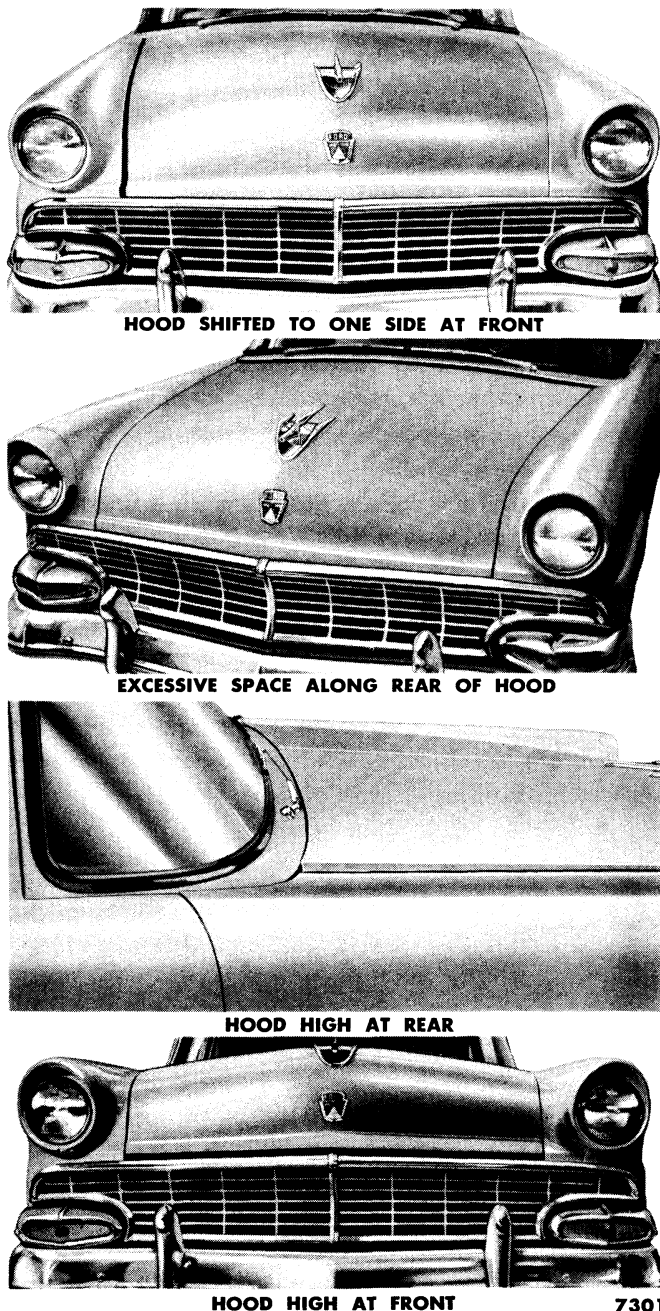

Fig. 27—Views of Incorrect Hood Alignment

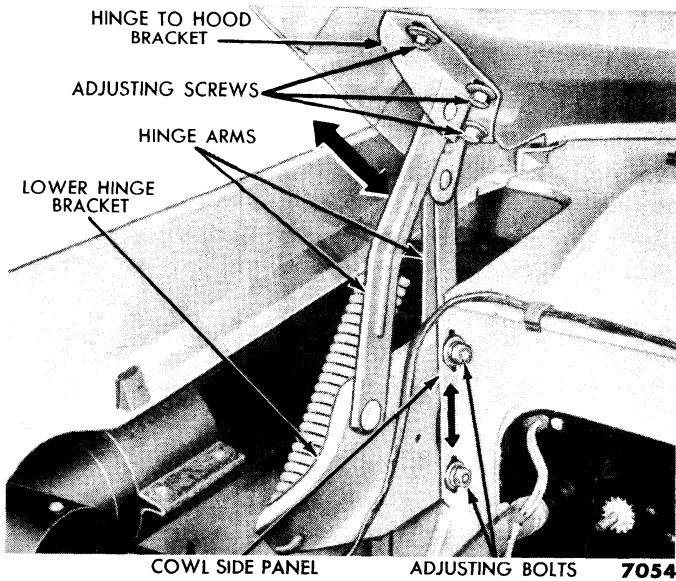

Fig. 28—Hood Hinge Adjustments

the cowl side panels (fig. 28). The two rear nuts for each hinge-to-cowl side stud can be reached from inside the car (fig. 26). Lower the brackets in the elongated holes until the top surface of the hood is flush with the cowl top panel when the hood is closed. Tighten the nuts.

d. Hood High at Front.

For proper adjustment, both sides of the hood should be flush with the fenders. If the front edge of the hood is higher than the fender at both sides (fig. 27), loosen the lock nut on each of the two adjustable rubber bumpers at the front end of the hood (fig. 29). Shorten the adjustable bumpers until the hood is flush with both fenders when closed. Tighten the lock nuts.

If the front end of the hood is high at one side only, loosen the lock nut on the adjustable bumper at the high side. Shorten the adjustable bumper until the high side of the hood is lowered to equal the height of the opposite side, and tighten the lock nut. After making either of the preceding adjustments, check the lock dowel adjustment for proper lock operation.

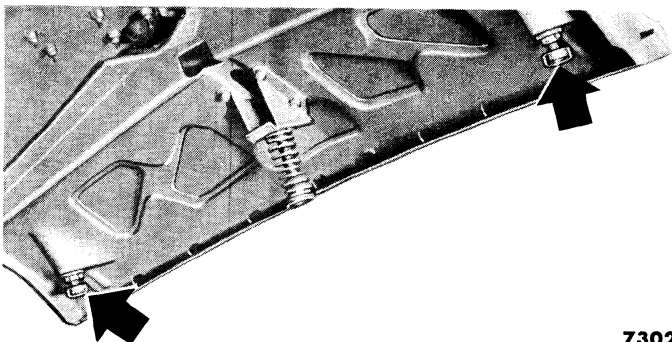

Fig. 29—Adjustable Rubber Bumpers

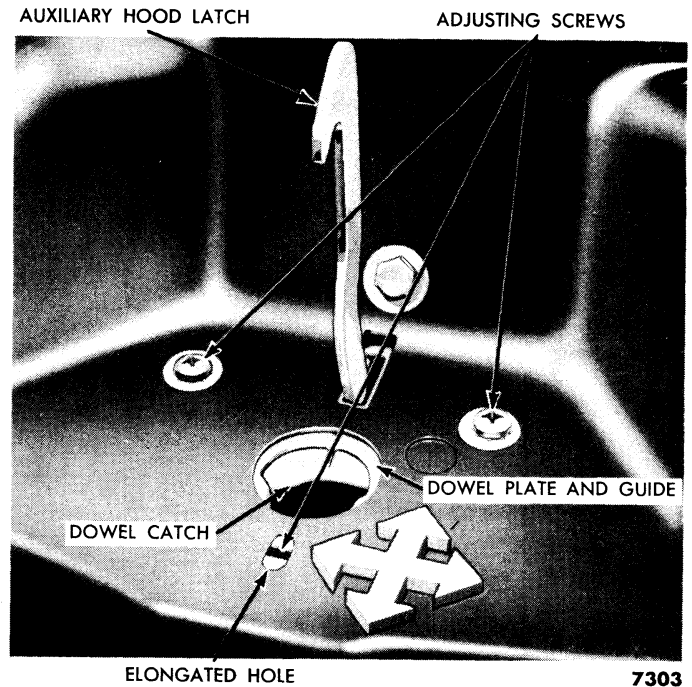

Fig. 30—Locking Plate Assembly

e. Adjustment of Hood Locking Plate Assembly.

After any horizontal shift of the hood loosen the adjusting screws at the locking plate (fig. 30). Move the entire locking plate assembly from side to side or forward or backward until the dowel is centered in the guide when the hood is closed. Tighten the adjusting screws.

Since the dowel guide plate, the dowel catch, the auxiliary hood latch, and the release handle are all assembled in one unit, the auxiliary hood latch moves whenever the entire locking plate assembly is moved. Therefore, the auxiliary latch is automatically adjusted when the plate assembly is adjusted.

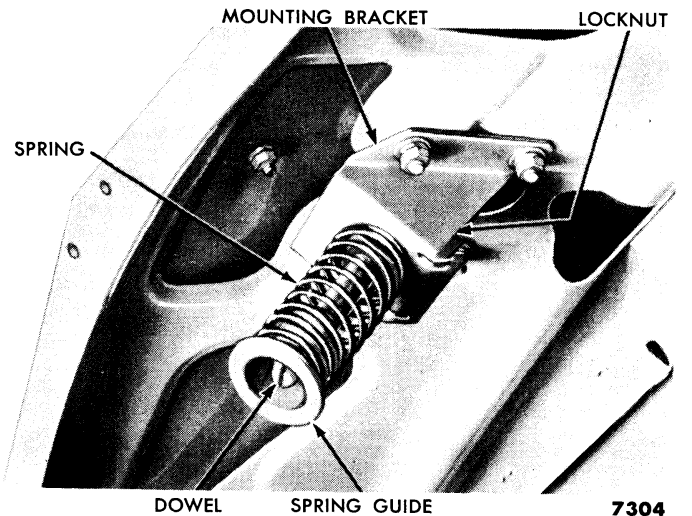

Fig. 31—Hood Lock Dowel Assembly

f. Lock Dowel Adjustment.

Before adjusting the lock dowel, adjust the rubber bumpers until the hood is flush with the fenders. Loosen the dowel lock nut behind the mounting bracket (fig. 31). Insert a screwdriver in the slot provided at the end of the dowel and shorten or lengthen the dowel to best locking position. If the hood has excessive UP and DOWN movement when locked, turn the dowel clock-

wise to decrease its length. The shortened dowel will draw the forward end of the hood down so that the two adjustable rubber bumpers will be held securely against the support panel. If the locking operation requires excessive pressure on the hood for engagement, or excessive pull on the release handle for disengagement, turn the dowel counterclockwise to increase its length. The lengthened dowel will relieve the excessive tension on the hood when it is locked.

7. THUNDERBIRD GRILLE AND HOOD

a. Grille Replacement.

Remove the two attaching nuts on each bumper guard, and remove the two guards. Working from underneath the stone shield, remove the screws that attach the lower grille moulding to the stone shield (fig. 32). Remove the side moulding at each side of the grille.

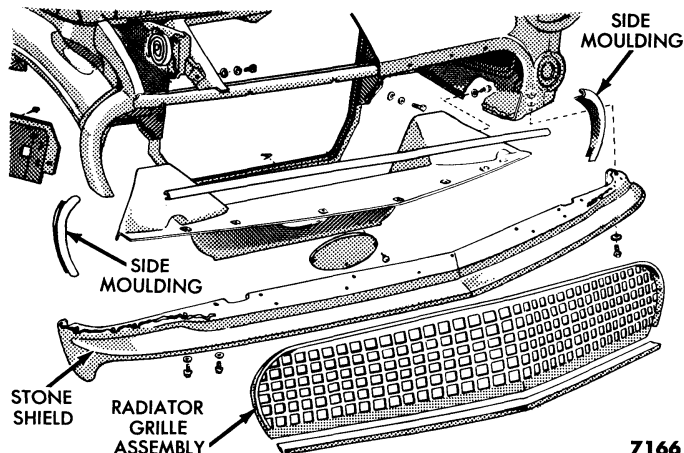

Fig. 32—Thunderbird Grille Assembly

Remove the grille attaching screws around the front of the grille, then remove the entire assembly from the front.

To install, position the grille in the opening and install the attaching screws around the front of the assembly. Install the moulding at each side of the grille. Secure the lower grille moulding to the underside of the stone shield with the attaching screws. Install the

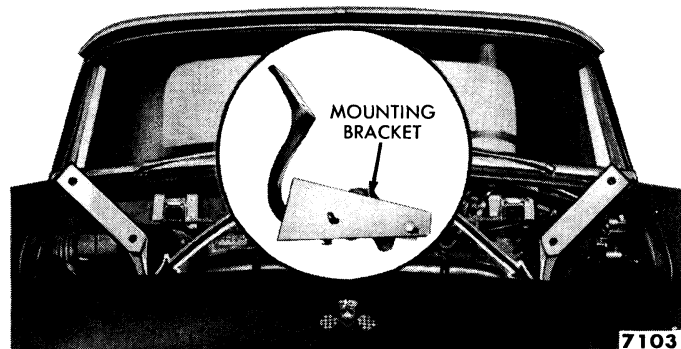

Fig. 33—Thunderbird Hood Hinge Mounting

bumper guards, and secure them with attaching nuts.

b. Hood and Hinge Replacement.

To remove the hood, pull the hood locking mechanism handle on the instrument panel, raise the hood, and remove the attaching screws at each hood hinge (fig. 33).

Mount the replacement hood on the hinges, in the raised position, and install the attaching screws at each hinge.

To replace the hood hinges, remove the hood from the hinges (fig. 33). Remove the bumper guards, the radiator grille, and the horns in order to gain access to the hood hinge brackets (insert, fig. 33). Remove the screws that attach the hinge to the mounting bracket, and remove the hinge through the grille opening.

Working through the grille opening, position each hood hinge to the mounting bracket, then install the two attaching screws. Install the horns, the radiator grille, and bumper guards.



Fig. 34—Thunderbird Hood Alignment

c. Hood Alignment.

The hood is mounted at the forward end on two hinges (fig. 34). The bolt holes are enlarged to permit fore and aft and lateral adjustment.

When the hood is closed, the two dowels at the rear end of the hood engage two corresponding lock mechanisms which are mounted at the fire wall (fig. 34).

The plates, into which the dowels are threaded, have bolt holes which are elongated for fore and aft adjustment. These bolt holes are also oversized to permit lateral adjustment. (insert, fig. 34). If the hood does

not close tightly, loosen the lock nut, and turn the threaded dowels clockwise to shorten them. If the hood closes or opens with difficulty, turn the dowels counterclockwise to lengthen them.

To adjust the front of the hood up or down, close the hood. Remove the access plate and, working through the access hole, loosen the hinge to bracket attaching screws. Shift the hood up or down in the elongated holes of the mounting bracket (insert, fig. 33). When the hood fits properly in the opening, tighten the hinge mounting screws; then replace the access plate.

8. FRONT FENDERS

a. Replacement.

Disassemble the headlight and parking light from the fender to be removed.

Remove the five fender-to-side air deflector screws and the two bolts and nuts that attach the lower front end of the fender to the stone deflector (fig. 35). Remove the three washer head screws that attach the lower front fender flange to the outer edge of the grille bar. Remove the three fender-to-apron attaching screws along the side.

At the lower rear of the fender, remove the fender-to-splash shield retaining screw and the fender-to-rocker panel screw (fig. 35). At the top rear of the fender, remove the hood bumper assembly from the top cowl panel, then remove the fender-to-top cowl panel mounting screw.

The rear side of the fender is attached to the hinge pillar by a stud, nut and lock washer (fig. 35). Pull back the floor mat, remove the kick pad, and remove the nut and lock washer from inside the vehicle.

The front inner flange of the fender is mounted between the radiator side air deflector and the hood lock support panel, and is held in position by three attaching

screws (fig. 36). The screws enter the support panel at the top, go through the bolt holes in the fender flange, and attach to the side air deflector underneath the fender. Remove the three screws.

In order to free the fender, remove the two inboard screws that attach the lock support panel to the brace and to the side air deflector (fig. 36). Pry the support panel away from the fender and air deflector, with a wooden wedge, then remove the fender from the vehicle.

Remove the three hood-to-fender rubber bumpers. If the removed fender was equipped with an emblem or trim mouldings, drill the necessary trim or emblem mounting holes in the replacement fender. Paint the fender to match the color of the vehicle. Assemble the trim moulding and emblem to the fender. Install the weatherstrip to the rear of the fender, and install the three hood-to-fender rubber bumpers.

CAUTION: Do not tighten any fender mounting screws, bolts or nuts until after the fender has been completely installed and adjusted.

Position the fender to the body with the inner front flange between the side air deflector and the hood lock support panel, then remove the wooden wedge. Install the three (panel through fender to side air deflector) retaining screws (fig. 36). Install a hex nut to the top

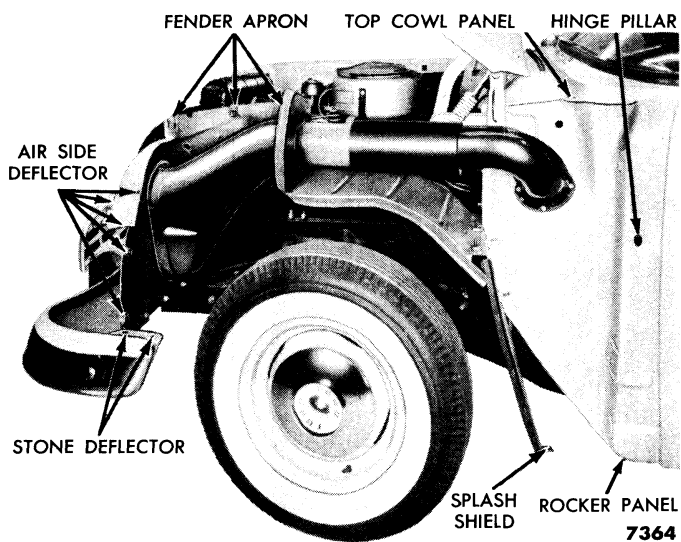

Fig. 35—Fender Mounting Points

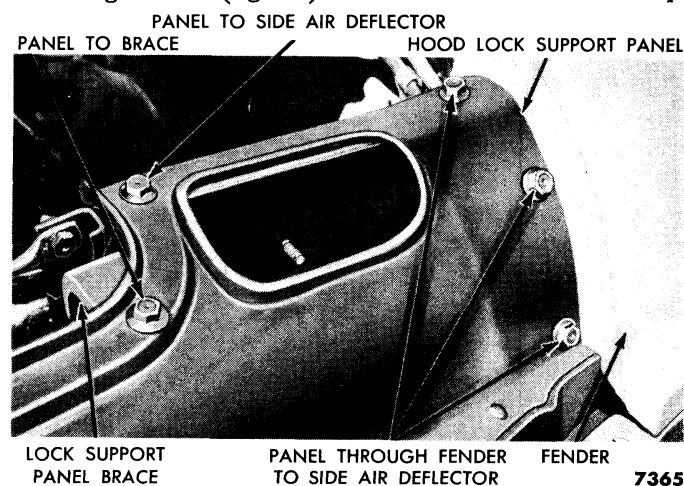

Fig. 36—Hood Lock Support Panel and Fender Mounting

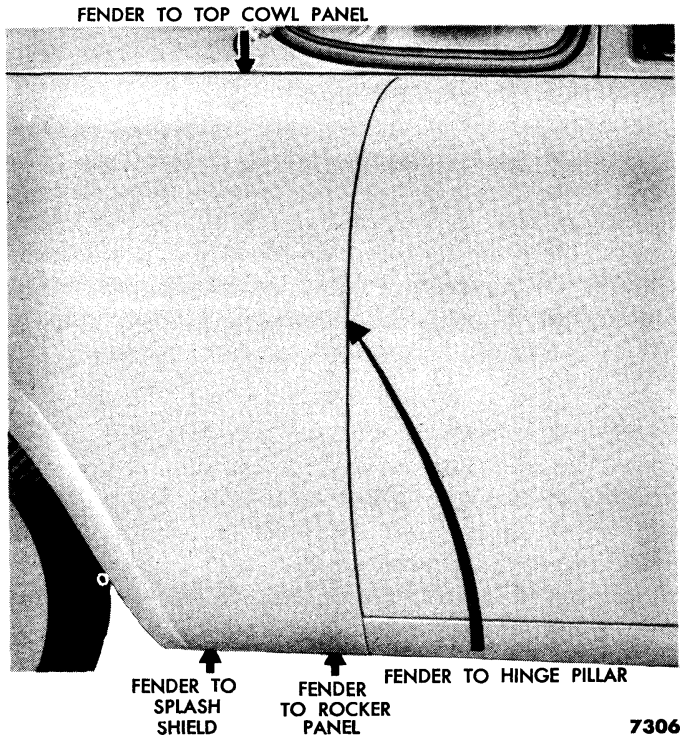

Fig. 37—Front Fender Adjustments

screw from underneath the air deflector flange. The other two screws engage retainer nuts in the air deflector. Install the two inboard screws, nuts, and washers (panel-to-brace and panel-to-air deflector).

Install the three washer-head screws that attach the lower front flange of the fender to the outer edge of the grille bar.

Install the three fender-to-apron screws along the side.

Install the seal on the mounting stud at the rear edge of the fender, and enter the stud through the hole in the hinge pillar (fig. 35). Install the stud retaining nut and lock washer from behind the kick pad inside the vehicle.

At the top of the rear fender, install the fender-to-top cowl panel screw and spacer washers, then attach the rubber bumper assembly to the fender and top cowl panel with a retaining screw (fig. 35). Install the lower rear fender retaining screw (fender mounting through spacer washers to caged nut in rocker panel).

Install the fender-to-splash shield screw, and the five fender-to-side air deflector screws, then attach the lower front of the fender to the stone deflector with two bolts, nuts and washers (fig. 35).

Align the fender, and tighten all attaching screws, bolts and nuts.

Install the headlight and parking light assemblies, and connect the wiring.

b. Fore and Aft Fender Adjustment.

Raise the hood and loosen the fender-to-top cowl panel screw (fig. 37). Loosen the lower fender attaching

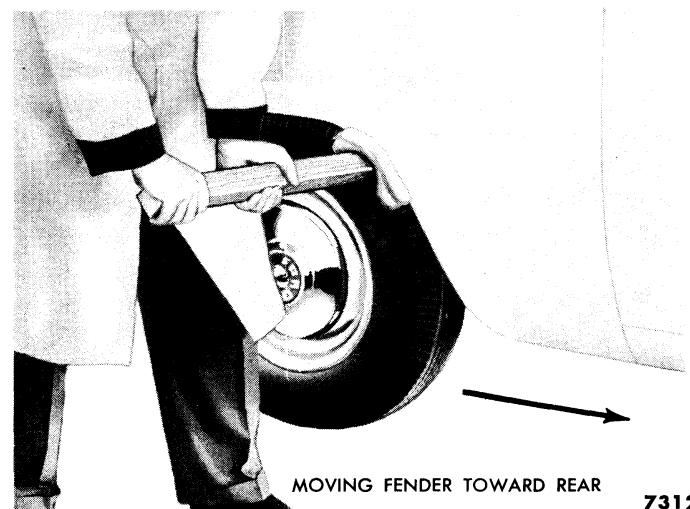
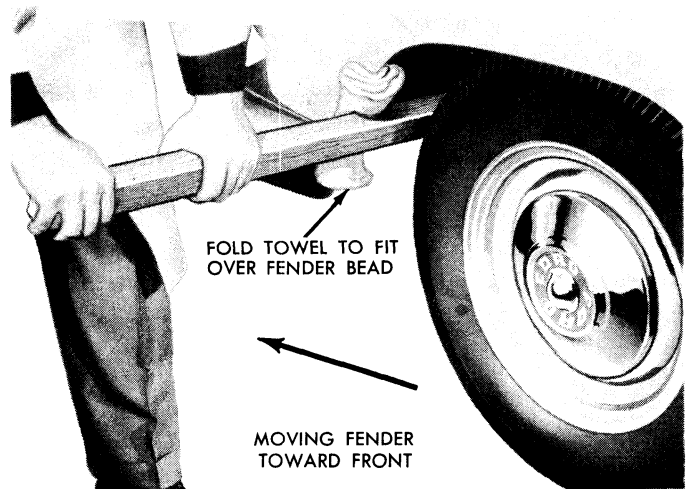

Fig. 38—Shifting Front Fender

screws (fender-to-rocker panel and fender-to-splash shield). Open the front door and remove the access hole cover plate from the front pillar face. Remove the cowl trim pad. Work through the access hole and loosen the center fender-to-hinge pillar nut. Loosen the fender apron screws. Place a pry bar between the tire and fender. To protect the finish on the fender, use a mechanic's towel or a rubber pad between the fender bead and pry bar. Pry the fender either forward or toward the rear to establish the correct clearance at the door line (fig. 38).

To avoid "spring-back," hold the fender in the desired position with the pry bar while the attaching nut, screws and bolts are tightened.

c. Up or Down Fender Adjustment.

Up and down adjustment is accomplished by shifting spacer washers between the upper (top cowl panel) and lower (rocker panel) fender attaching screws (fig. 37). To lower the fender, remove the spacers at the upper attaching screw and place them at the lower attaching screw. Reverse the procedure to raise the fender.

Part FOUR

BODIES

Chapter

IV

Power Installations and Special Items

Section	Page
1 Power Windows	331
2 Power Seats	337
3 Convertible Top	342
4 Thunderbird Top Adjustments	347
5 Care of Country Squire Paneling	349
6 Crown Victoria Transparent Top	350

This chapter covers power units which can be installed as special equipment on all models, as well as items which are peculiar to certain models only.

Electrically operated power windows and power seats are available, as optional equipment, for all vehicles. Electrical circuits and trouble shooting and replacement procedures are given for these power options.

The convertible top is operated by a mechanical linkage which is actuated hydraulically by an electric motor. Trouble shooting, replacements, and adjustments of the

top operating mechanism are covered in this chapter.

Most of the body service information on the Country Squire, and other station wagon models, is given elsewhere in this manual. The procedures given in this chapter cover only the repair and maintenance of the Country Squire panelling and side rails.

The Crown Victoria is available with either a hard top or a transparent top. The replacement and maintenance procedures for the transparent top are presented in this chapter.

1. POWER WINDOWS

Power windows are available, as optional equipment, for all models. In a power window installation, the window regulator mechanism is actuated by an electric motor. The regulator mechanism is basically the same for all models. However, certain design differences are necessary to adapt the regulator installation to the various types of doors and quarter panels. The electrically actuated regulator is adjusted in the same manner as the manually operated regulator.

The information, that is given in this section, on construction and operation, replacement of assemblies, and trouble shooting, applies to all models.

a. Construction and Operation.

The power windows are driven by an electric motor coupled with a drive assembly which actuates the regulator assembly.

Each window has a control switch, a relay, and a motor. Figure 1 shows how these parts are connected in either the control circuit or power circuit. The power

circuit starts at a 30 ampere circuit breaker under the instrument panel (red wire with blue band), leads through the relay switch at each door, and goes through the motor armature to ground. The control circuit starts at a 15 ampere circuit breaker also under the instrument panel. This circuit breaker is connected to the accessory terminal of the ignition switch. From the circuit breaker, the control circuit (black with white band) leads to the manual control switch at each window. From the control switch, the current splits and flows through the relay coil and the field coils of the motor to ground. There is also a 15 ampere circuit breaker in the ground lead at each motor.

When the manual control switch is closed (button pushed up or down), current flows from the ignition switch terminal through the relay coil (fig. 1). The current energizes the coil which closes the relay contacts. When closed, the relay connects battery current to the motor armature. At the same time, current also flows to one of the motor field coils. With the control button

pushed up, this current flows through one of the field coils causing rotation in one direction; with the button pushed down, the current flows through the other field coil causing the armature to rotate in the opposite direction. Thus, the motor can be rotated in either direction for raising or lowering the window.

NOTE: The windows may be stopped in any position by releasing the control switch.

The multiple switch, located on the left door trim panel, acts as a master control, and is connected in parallel with the switches located on the other three doors. The wire lead from the 15 ampere circuit breaker

(control circuit) is attached to the accessory side of the ignition switch. Thus, the windows can not be operated unless the ignition switch is turned on.

b. Replacement Procedures.

The electric window mechanism consists of a motor, a drive coupling, a drive gear assembly, and a regulator assembly (fig. 2). Each of these components are serviced as a separate assembly. Although the replacement procedures given here apply in general to all electric windows, there are some differences in the Convertible and Victoria quarter window procedures. These differences are pointed out.

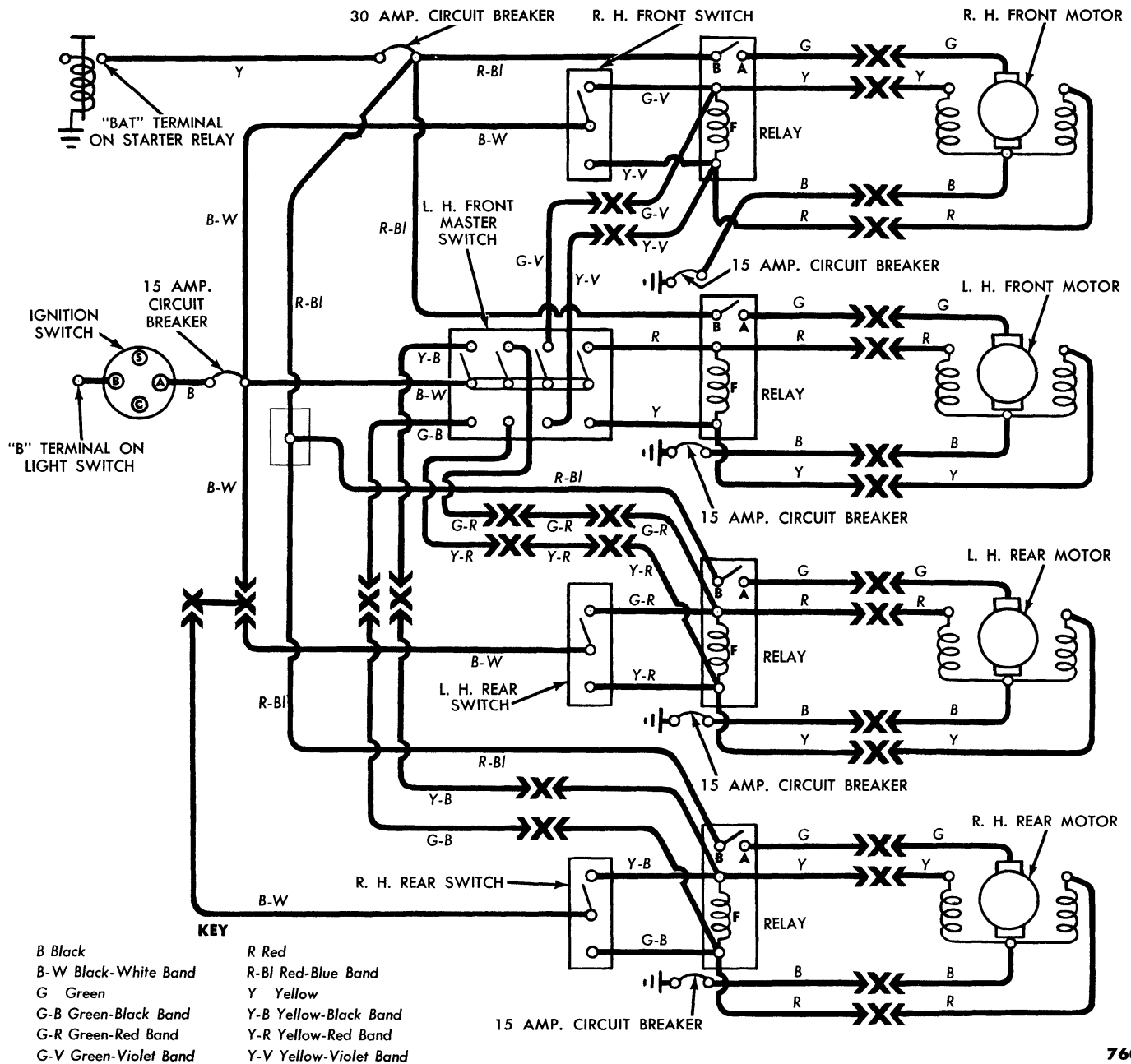

Fig. 1—Window Regulator Electrical Circuit

Before replacing any one of the units shown in fig. 2, lower the glass all the way, and disconnect the ground cable from the battery. Remove the door handle and garnish moulding. Loosen the trim panel attaching screws, and pull the top of the trim panel away from the door or quarter panel. Disconnect the wires from the bullet type connections on the control switch, then remove the trim panel.

With these preliminary steps accomplished, any one of the following service operations can be performed.

(1) **MOTOR ASSEMBLY AND RELAY.** Disconnect the wires to the motor at the bullet connections (fig. 3). Disconnect the wires to the relay, remove the attaching screws, then remove the relay. The Convertible quarter window relay is mounted on the outside of the quarter panel forward of the access hole, the Victoria quarter window relay is mounted on the rear seat riser, and the relay on all other windows is mounted to the inner door or quarter panel just above the access hole.

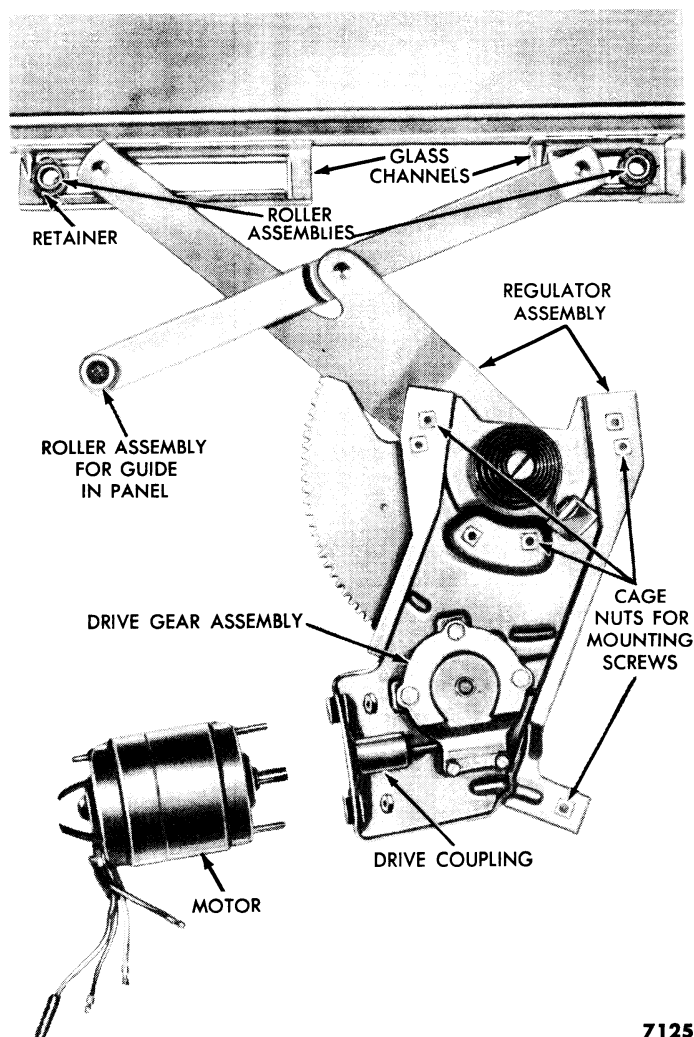

Fig. 2—Electric Window Regulator Assembly

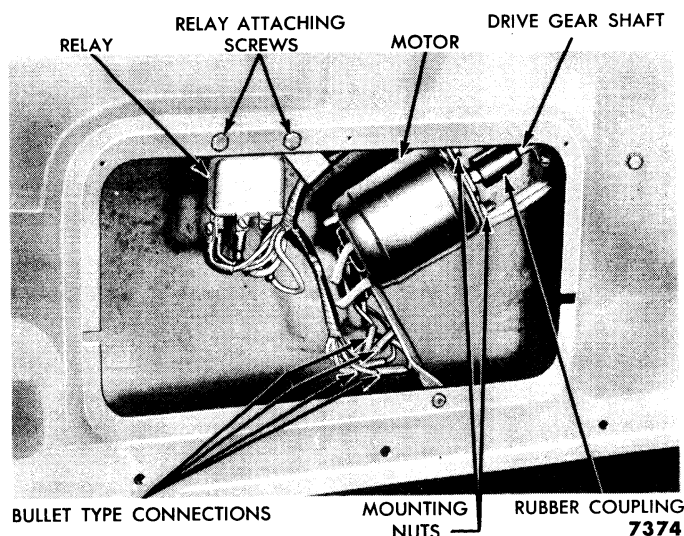

Fig. 3—Motor and Relay Replacement

On all except Convertible and Victoria quarter windows, remove the motor-to-panel brace (fig. 3).

Remove the motor mounting nuts and washers. Remove the motor through the panel access hole. If the rubber coupling is worn or damaged, remove it from the drive gear shaft.

To install, slide the small slot of the rubber coupling on the drive gear shaft. Pull the plastic cover on the motor. Secure the plastic cover around the motor with tape. Position the motor with the studs in the regulator mounting holes and the motor shaft in the large slot in the coupling (figs. 2 and 3). Install the mounting nuts and lock washers. It is important that lock washers be used and that the nuts be tightened securely. Connect the motor wires to the bullet connectors. Install the brace between the motor and door or quarter panel (except Convertible or Victoria). Mount the relay with the attaching screws and connect the relay wires.

(2) **REGULATOR ASSEMBLY.** The procedure for removing the regulator is the same on all power windows except the Victoria quarter window.

(a) **ALL EXCEPT VICTORIA.** Disconnect the wires to the motor and relay, and remove the relay (fig. 3). Remove the motor-to-panel brace.

On rear doors, remove the screw that attaches the circuit breaker to the regulator support bracket and regulator assembly, remove the screws that attach the support bracket to the inner door panel, then remove the circuit breaker and regulator support bracket (fig. 5). Working through the door access hole, partially remove the spring retainers from the roller assemblies in the glass channels, and disengage the regulator arms from the rollers (fig. 2).

Raise the window glass manually, wrap several strips of adhesive material over the top of the door, and stick

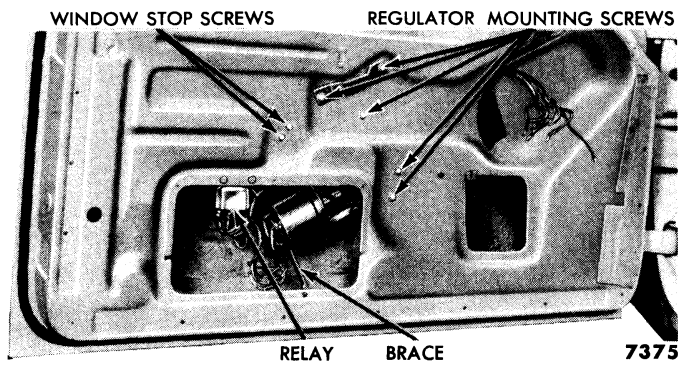

Fig. 4—Electric Window Regulator Replacement—Front Door

the ends to each side of the glass. Remove the mounting screws that secure the regulator assembly to the inner door panel (figs. 4 and 5). Slide the regulator assembly forward to release the roller from the guide on the inner door panel. Lower the assembly, and remove it through the access hole.

Remove the motor from the regulator assembly, and install it on the replacement regulator (fig. 2).

NOTE: Before installing the regulator assembly, apply Lubriplate to the rollers and all pivot points.

If the rollers were disassembled, first assemble the rollers in the glass channel, then raise the regulator assembly into the door panel. Before locating the mounting screw holes, start the upper roller into the guide in the panel. Install the mounting screws, but do not tighten them at this time.

Install the relay and connect the wires to the relay and motor. Shift the regulator assembly into proper adjustment as outlined in Chapter II, and tighten the mount-

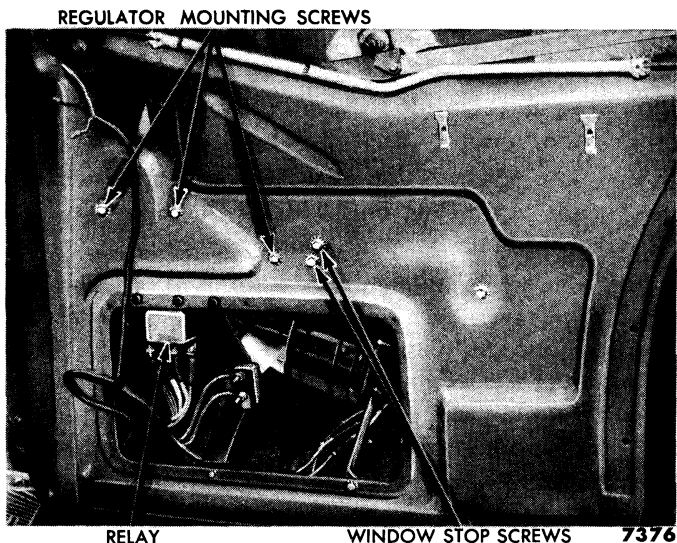

Fig. 5—Electric Window Regulator Replacement—Rear Door

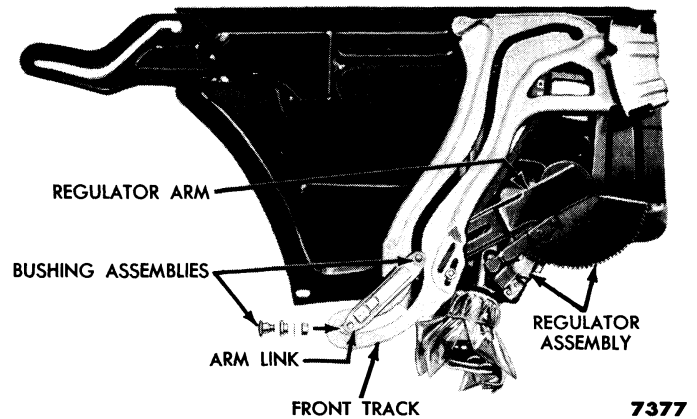

Fig. 6—Victoria Quarter Window Regulator

ing screws (figs. 4 and 5). Install the motor-to-panel brace.

On rear doors, mount the regulator support bracket to the door inner panel (2 attaching screws), mount the circuit breaker to the regulator support bracket, and install the screw that attaches the circuit breaker and regulator to the support bracket (fig. 5).

(b) VICTORIA. Disconnect the wires to the motor and relay. Remove the entire glass and regulator panel assembly from the body, and remove the glass from the panel as outlined in Part Four, Chapter II.

Remove the arm link and bushing assemblies in order to disengage the regulator arm from the front track (fig. 6). Remove the four regulator attaching screws from the outer side of the panel, then remove the regulator assembly from the panel.

Remove the motor from the regulator and assemble it to the replacement assembly.

Install the regulator assembly between the front track and the panel assembly (fig. 6). Install the four regulator attaching screws from the outer side of the panel. Connect the regulator arm to the front track by installing the arm link and bushing assemblies (fig. 6).

Install the glass to the panel assembly, mount the glass and panel to the body, and make necessary adjustments as outlined in Part Four, Chapter II.

(3) **DRIVE GEAR ASSEMBLY.** Remove the regulator assembly from the door or quarter panel, and remove the motor from the regulator.

Before the drive gear assembly can be removed, the spring must be unloaded by disengaging the regulator sector teeth from the pinion gear. This procedure is illustrated with the convertible quarter regulator but it applies to all power window regulators.

The purpose of the regulator spring is to assist the motor in raising the window. Therefore, the spring winds to the loaded position as the window and regulator arm are brought to the down position. To unload the spring, hold the regulator arm slightly against spring pressure

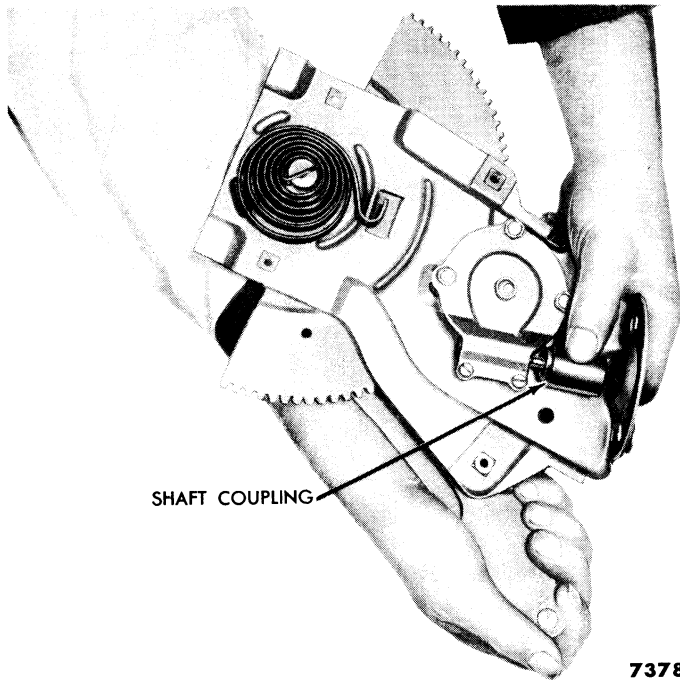

Fig. 7—Regulator Arm in Down Position—Spring Loaded

and rotate the drive gear shaft at the rubber coupling (fig. 7). Continue rotating the shaft, until the arm is brought to the up position and the sector teeth disengage from the pinion (fig. 8). With the sector disengaged from the pinion gear, the spring and drive gear assembly can be removed (fig. 9). Remove the three mounting screws and lift the drive gear assembly from the regulator.

Before installing the drive gear assembly, be sure to swing the arm and sector teeth far enough away to avoid interference with the pinion, then install the replacement assembly with the dowel pins entering the holes (fig. 10).

Install the mounting screws and spring as shown in fig. 9. Swing the sector teeth against the pinion, and

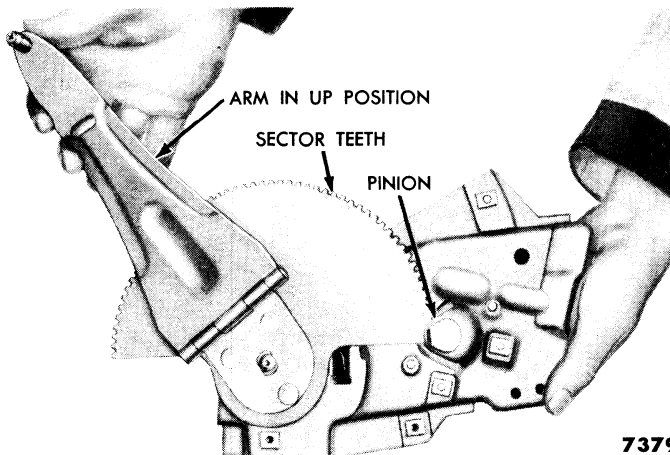

Fig. 8—Engagement of Sector Teeth with Pinion

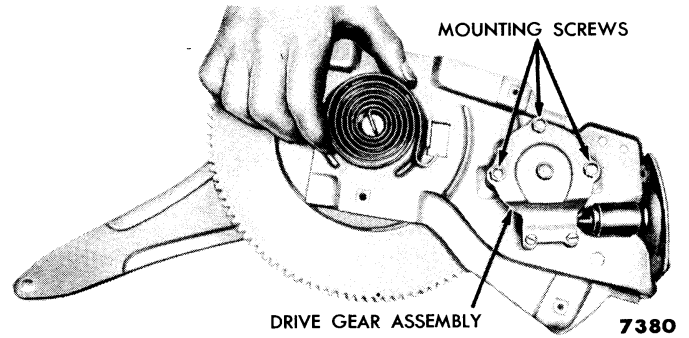

Fig. 9—Regulator Arm in Up Position—Spring Unloaded

rotate the shaft to bring them into engagement (fig. 8). Continue rotating the shaft until the regulator arm swings around to the down position and loads the spring (fig. 7). The shaft can be more easily turned, if the arm is held slightly against spring pressure during rotation.

Assemble the motor to the regulator, and mount the assembly to the door or quarter panel.

c. Electrical Trouble Shooting.

The following procedures will eliminate the troubles most commonly encountered. Before proceeding with any of these operations, the battery should be fully charged, and the ignition switch turned to the accessory position.

(1) **ALL WINDOWS DO NOT OPERATE.** If none of the windows operate, either the circuit breaker that protects the power circuit, or the circuit breaker that protects the control circuit, is open. Both circuit breakers are located under the instrument panel. Check for voltage at the circuit breaker (power circuit), at the terminal where the three red and blue wires are attached. If there is no voltage at this point, the trouble is in the power circuit. If there is voltage at this terminal, the trouble is probably in the control circuit.

NOTE: When the following procedures require operation of the control switch, be sure to operate them in both directions. Also, do not operate after the

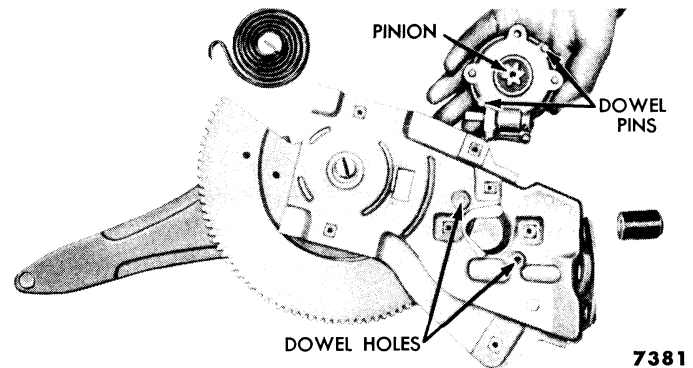

Fig. 10—Drive Gear Replacement

window has reached its limit of travel. Such operation would result in a false current reading.

(a) **POWER CIRCUIT.** Check the battery side of the circuit breaker of the power circuit (terminal connected to yellow wire) for voltage. If there is no voltage, check for defective wiring between the circuit breaker and the battery terminal of the starter relay (fig. 1). Repair or replace as necessary. If there is voltage at this terminal, connect an ammeter across the circuit breaker. If current is indicated on the ammeter (all control switches open), check the wiring from the circuit breaker to each of the relays (red with blue band). Repair or replace grounded wiring as necessary. If no current is indicated, operate all the control switches, (including master switch); and, if the current is normal in each case (6-14 amperes), replace the circuit breaker. If the current exceeds 14 amperes when any control switch is closed, check the green wire between the relay and the motor of the applicable window unit. Repair or replace grounded wiring as necessary, and check for tight or binding windows. Close the control switch again, and if the current is still excessive with the windows free of binding, or replace the motor.

(b) **CONTROL CIRCUIT.** Check the switch terminal (three black wires with white band connected) of the circuit breaker (control circuit) for voltage. If there is no voltage, check the opposite or hot terminal. If the hot terminal (black wire attached) indicates no voltage, check for defective wiring between the circuit breaker and the ignition switch. Repair or replace as necessary. If voltage is indicated at the hot terminal, connect an ammeter across the circuit breaker. If current is indicated on the ammeter (all control switches open), check the wiring (black with white band) between the circuit breaker and each of the switches. Repair or replace grounded or defective wiring as necessary. If no current is indicated, close the control switches one at a time (including master switch), and check the current through each switch. If the current is normal (6-10 amperes) in each case, replace the circuit breaker. If the current exceeds 10 amperes when any control switch is closed, disconnect the two field wires (one yellow, one red) at the motor operated by that switch. With the field wires disconnected, close the control switch again; and if the current now indicates no amperage, replace the motor. If the current is still excessive, check the two field supply wires and the wires between the switch and the relay. Repair or replace defective or grounded wires. If the wiring is in good repair, and the current is still excessive when the switch is closed, replace the relay.

NOTE: *Since the power window, the power seat, and the convertible top operating systems are connected to the same circuit breakers, a defect in any one*

system could cause one of the circuit breakers to open and thus render the other systems inoperative. Therefore, if none of the above procedures restore window operation, check the power seat circuits; and on convertibles, also check the top circuits.

(2) **ONE WINDOW DOES NOT OPERATE.** If any one unit does not operate, first check the motor to be sure that loose motor mounting nuts have not caused the drive coupling to slide off the shaft. Turn the ignition switch to the accessory position, and operate the control switch of the window in question. Listen for the relay to click. If the relay does not click, the trouble is in the control switch, the relay, or the connecting wires. If the relay does click, the trouble is in the motor or its connecting wires.

(a) **SWITCH AND RELAY TEST.** Check the voltage at the hot terminal (connected to black wire with white band) of the switch (fig. 1). No voltage, at this point, indicates defective wiring between the switch and the circuit breaker (control circuit). Repair or replace the wiring. If voltage is available, install a jumper wire from the hot lead of the control switch to one of the F terminals of the relay. If the relay now clicks, replace the switch. If the relay does not click, ground the other F terminal of the relay and repeat the test. If the relay still does not click, replace the relay.

(b) **TEST OF MOTOR AND CONNECTING WIRES.** Check for voltage at the B terminal of the relay (fig. 1). No voltage at this point indicates defective wiring between the relay and the circuit breaker of the power circuit (red with blue band). Repair or replace the wire. If voltage is available, check the green wire between the relay and the motor. Repair or replace wiring as necessary. If the unit still does not operate, replace the motor.

(3) **WINDOW OPERATES IN ONE DIRECTION ONLY.** Check both the window switch and the driver's control switch. If one switch will operate the unit in both directions and the other will not, repair or replace the connecting wires or switch, whichever applies, of the non-operating switch.

If both the window switch and the driver's control switch will operate the window in only one direction, follow the instructions given in "(a) Switch and Relay Test" as outlined under "(2) One Window Does Not Operate." If this procedure does not correct the trouble check the condition of the two field wires (one red, one yellow) between the relay and motor. Repair or replace as necessary. If the motor still operates in only one direction, one of the motor field coils is open. Replace the motor.

(4) **WINDOW OPERATES OPPOSITE TO SWITCH.** If a window goes up when the switch is

pushed down and visa versa, the wires between the switch and the relay of that window are crossed. Connect the wires to their proper terminals as shown in fig. 1.

(5) **WINDOW OPERATES SLUGGISHLY.** Sluggish operation of a window may be caused by any or all of the following items:

(a) **BINDING WINDOW REGULATOR.** Operate the window by turning the motor drive shaft by hand. The mechanism should operate without difficulty. If it does not, find the reason for the bind. Apply lubriplate and make the proper window adjustment to relieve the bind.

(b) **RELAY FLUTTER.** If sluggish operation continues even after elimination of the bind and a clicking relay

noise is heard, replace the relay.

(c) **BROKEN WIRES OR LOOSE CONNECTIONS.** Inspect for broken wires or worn insulation. Repair or replace any defective wires. Make certain that all connections are tight and that there is no paint under the wire terminals where they attach to the car body.

(d) **WORN MOTOR BRUSHES.** Remove the motor, and check the motor no load current draw. Remove only the motor ground lead, and place the ammeter in series with the lead and ground. Operate the window switch, and observe the current. With no load, the current draw should be approximately 8-10 amperes at 12 volts. Worn or dirty brushes are indicated by low current. In such a case, replace the motor.

2. POWER SEATS

The electric power seat system, available as optional equipment on all models, is of the screw and jack type. Included in the system, are the necessary connections to operate both seat tracks, either vertically or horizontally. Operating principles, the electrical circuit, electrical trouble shooting, and replacement procedures are discussed in this section.

a. Operating Principles.

The power seat mechanism consists of a seat frame, track assembly, seat regulators (vertical and horizontal), relays, a four-way toggle switch, and the necessary wiring (two separate switches on the Thunderbird).

Fore and aft movement is accomplished through the horizontal regulator. When in operation, the horizontal regulator either pushes the seat forward or pulls the seat to the rear, depending on driver requirements.

When a forward position of the seat is required, the horizontal regulator is extended by means of a screw

and jack which is a part of the horizontal seat regulator. This regulator is located under the left side of the front seat (fig. 11). One end of the regulator is attached to a bracket mounted on the forward edge of the seat frame (fig. 12). The other end of the regulator is attached to the left-hand seat track mounting bracket which is bolted to the floor pan. When the regulator rolls the seat forward, pressure is applied to the seat frame. Since the upper seat tracks are bolted to the seat frame, the upper tracks will slide on the lower tracks which are attached to the stationary mounting brackets (figs. 11 and 12).

The upper seat tracks are connected by means of a horizontal equalizer bar which has an integral pinion

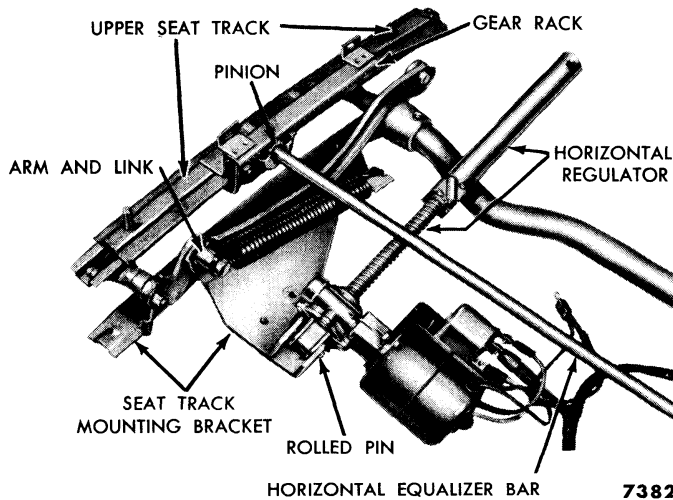

Fig. 11—Power Seat Assembly—Left Side

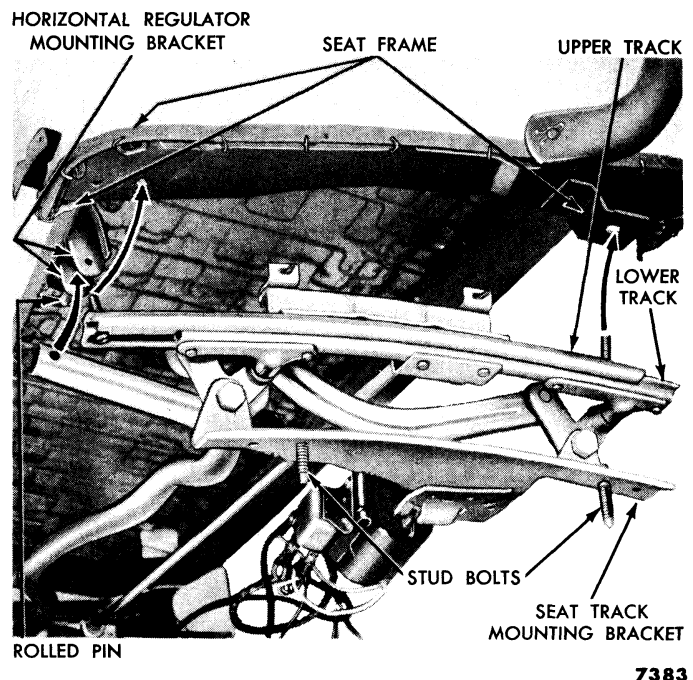

Fig. 12—Power Seat and Frame Attaching Points

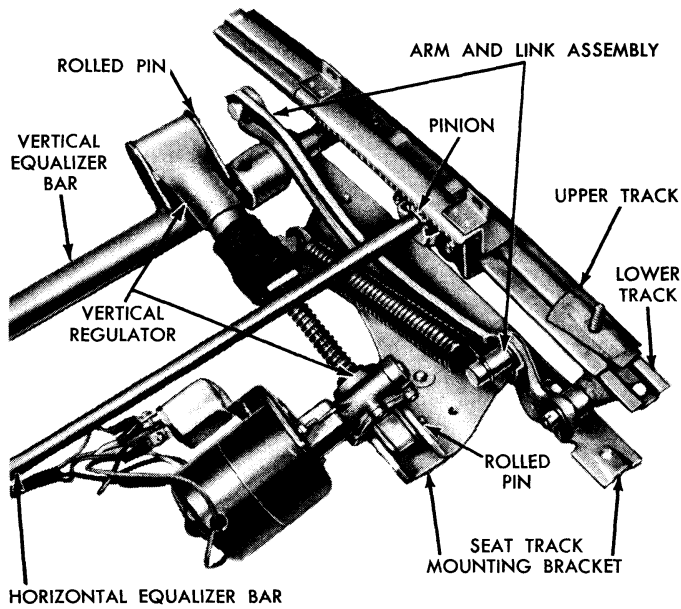

Fig. 13—Power Seat Assembly—Right Side

gear at each end. The equalizer bar and gears rotate in two brackets one of which is mounted at each lower (stationary) track. The pinion gears engage racks mounted to each upper (sliding) track. The force of the horizontal regulator against the left-hand track assembly is transferred equally through the equalizer bar, pinion gears, and racks to the right-hand track assembly (figs. 11 and 13).

The vertical action of the power seat is accomplished through the vertical regulator. One end of this regulator is attached to the right side seat track mounting bracket. The other end of the regulator is attached to a bracket welded to the vertical equalizer bar (fig. 13). The ends of the vertical equalizer bar are connected to the track assembly through an arm and link mechanism. When a vertical seat adjustment is required, the four-way control switch activates the vertical seat regulator. Since the vertical seat regulator is equipped with a screw and jack, vertical movement of the seat can be accomplished through the vertical equalizer bar and the arm and link assemblies at each end.

The Thunderbird power seat has the same electrical circuit, regulator assemblies, and general principles of operation as the conventional car. However, the regulators are mounted differently, and only one equalizer bar is used. One end of the horizontal regulator is attached to a bracket mounted on the forward edge of the front seat. Although this mounting is on the left side of the seat, it is closer to the center than the mounting on the conventional car. Thus, the need for a horizontal equalizer bar is eliminated. The other end of

the horizontal regulator is attached to a bracket mounted in the floor pan.

The vertical regulator is attached at one end to a bracket mounted in the lower back panel, and at the other end to a bracket that is welded to the center of the vertical equalizer bar.

NOTE: *The Thunderbird has two separate switches mounted on the door panel instead of the four-way toggle switch used on conventional models.*

b. Electrical Circuit.

Each seat regulator has a relay and an electric motor. Figure 14 shows how these parts are connected into either the power circuit or the control circuit. The power circuit starts at a 30 ampere circuit breaker under the instrument panel (red with blue band), leads through the electrical contacts in each relay, and goes through the motor armature to ground. The control circuit starts at a 15 ampere circuit breaker also under the instrument panel. This circuit breaker is connected to the accessory terminal of the ignition switch. From the circuit breaker, the control circuit (black with white band) leads to a manually-controlled, four-way, toggle switch which is mounted on the left front seat shield (Thunderbird, two switches mounted on door panel). From the toggle switch, the current splits and flows through the relay coil and the field coils of the motor.

When the toggle switch is moved to the forward position, current flows from the ignition switch terminal through one of the motor field coils and also through the coil of the horizontal regulator relay (fig. 14). The current energizes the relay coil which closes the contacts. The closing of the relay causes battery current to flow to the motor armature. The motor turns the screw jack in such a way as to move the seat forward.

When the toggle switch is moved to the rear position, the current flows through the other field coil causing the motor to rotate in the opposite direction. This reversal of the motor turns the screw jack in such a way as to move the seat backward in its track.

When the toggle switch is moved upward or downward, current flows to the vertical regulator motor, and the seat moves in the direction which corresponds to the movement of the switch.

The wire lead from the circuit breaker (control circuit) is attached to the accessory side of the ignition switch. Consequently, the seat regulator mechanism can not be operated unless the ignition switch is turned on.

c. Electrical Trouble Shooting.

The following procedures will eliminate the troubles most commonly encountered. Before proceeding with

any of these operations, make sure that the battery is fully charged and that the ignition switch is turned to the accessory position.

(1) **BOTH REGULATORS INOPERATIVE.** If neither regulator will operate, one of the following circuit breakers may be open: the circuit breaker that protects the power circuit; the circuit breaker that protects the control circuit; or the 15 ampere circuit breaker in the common motor ground lead (conventional models) (fig. 14). The first two (power and control circuits) are located under the instrument panel; the third (in the motor ground lead) is mounted on the floor pan under the seat. Check for voltage at the relay terminal of the circuit breaker (power circuit) (red wire with blue band). If there is no voltage at this point, the trouble is in the power circuit. If there is voltage at this terminal, the trouble is probably in either the common ground or in the control circuit. Close the toggle switch and if the relay clicks, the trouble is probably in the common ground. If the relays do not click the trouble is in the control circuit.

(a) **POWER CIRCUIT.** Check the battery side of the circuit breaker of the power circuit (terminal connected to yellow wire) for voltage. If there is no voltage, check for defective wiring between the circuit breaker and the battery terminal of the starter relay (fig. 14). Repair or replace as necessary. If there is voltage at this terminal, connect an ammeter across the circuit breaker. If current is indicated on the ammeter (toggle switch open), check the wire between the circuit breaker and the horizontal regulator relay, and the wire between the two relays (red with blue band). Repair or replace grounded wires as necessary. If no current is indicated, operate the toggle switch in all four directions (two separate switches on Thunderbird), and check the current with the switch closed in each of the four positions. If the current is normal in each case, replace the circuit breaker. If the current exceeds 14 amperes when the toggle switch is closed in any one of the four positions, check the green wire between the relay and the motor of the applicable regulator unit. Repair or replace defective or grounded wiring as necessary, and check

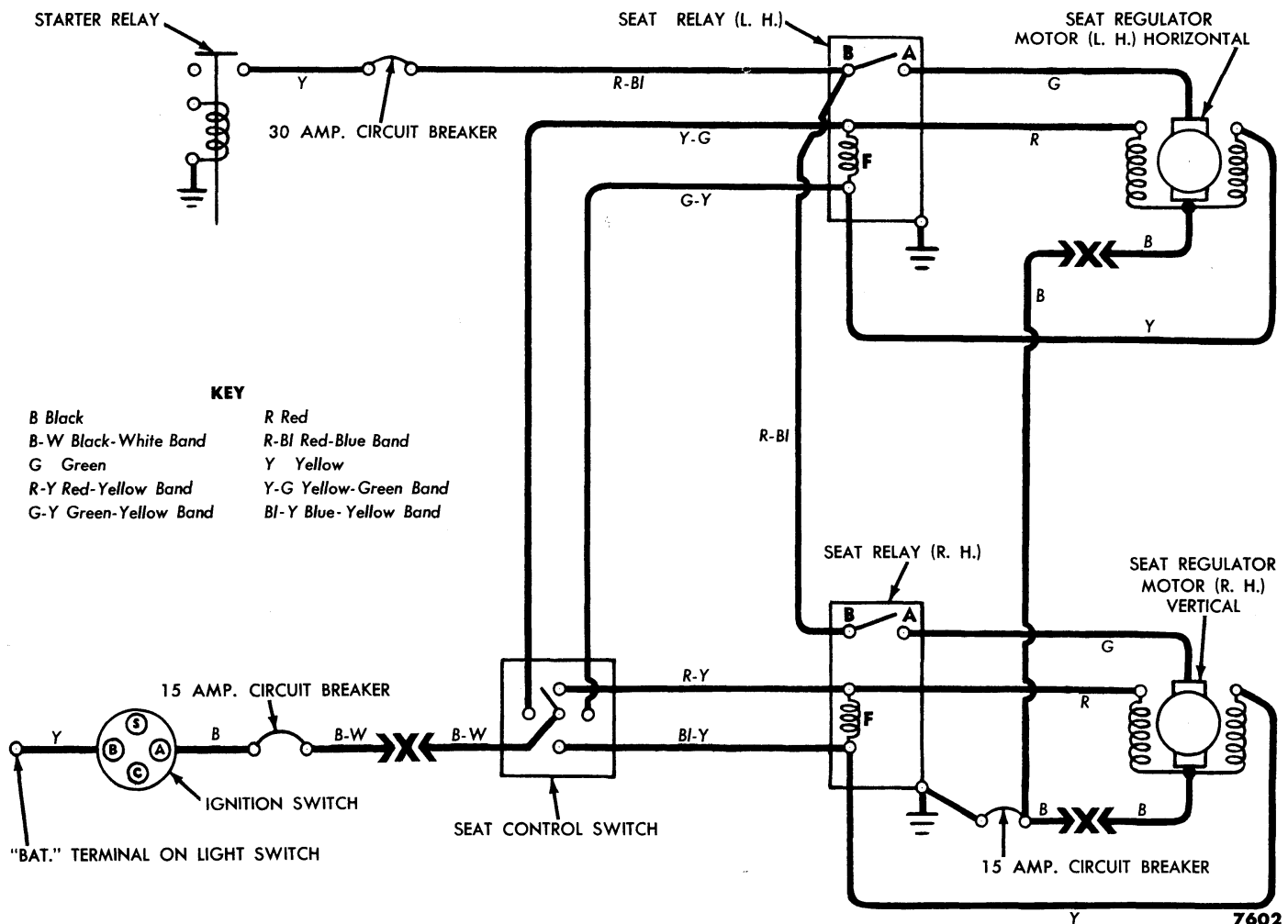

Fig. 14—Four Way Seat Electrical Circuit

the seat mechanism for binding. Close the toggle switch in the same position again, and if the current is still excessive with the seat free of binding, replace the motor.

(b) **COMMON GROUND.** Run a jumper wire from the ground terminal of the 15 ampere circuit breaker (under the seat) to ground and close the toggle switch. If the regulator operates, replace the wire between the circuit breaker ground terminal and ground (fig. 14). If the regulator does not operate, ground the opposite terminal of the circuit breaker and close the toggle switch. If the regulator now operates replace the circuit breaker. If the regulator still does not operate, check for defective ground wiring (black) from both motors. Repair or replace as necessary. If the ground wiring is in good condition, check the circuit from the 30 ampere circuit breaker through the motors as outlined in "(a) Power Circuit."

(c) **CONTROL CIRCUIT.** Check the switch terminal of the 15 ampere circuit breaker (control circuit) for voltage. If there is no voltage, check the opposite or hot terminal. If the hot terminal (black wire attached) indicates no voltage, check for defective wiring between the circuit breaker and the ignition switch. Repair or replace as necessary. If voltage is indicated at the hot terminal, connect an ammeter across the circuit breaker. If current is indicated on the ammeter (toggle switch open), check the wire (black with white band) between the circuit breaker and the toggle switch. If the wire is grounded or defective, repair or replace as necessary. If no current is indicated, close the toggle switch in each of the four positions, and check the current through each of the four switch terminals. If the current is normal in each case, replace the circuit breaker. If the current exceeds 10 amperes when the toggle switch is closed in one of the four positions, disconnect the two field wires (one red, one yellow) at the motor operated by that position of the toggle. With the field wires disconnected, close the toggle switch in the same position again, and if the current now indicates no amperage, replace the motor. If the current is still excessive, check the two field supply wires and the wires between the relay and the toggle switch. Repair or replace grounded or defective wires. If the wiring is in good repair and the current is still excessive when the switch is closed, replace the relay.

NOTE: *Since the power window, the power seat, and convertible top operating systems are all connected to the same circuit breakers, a defect in any one system could cause one of the circuit breakers to open and thus render the other systems inoperative. Therefore, if none of the above procedures restore power*

seat regulator operation, check the power window circuits; and on convertibles, also check the top circuits.

(2) **ONE REGULATOR INOPERATIVE.** If one regulator operates and the other does not, move the toggle switch to the position which normally causes the defective regulator to operate. Listen for the relay to click. If the relay does not click, the trouble is in the control switch, the relay, or the connecting wires. If the relay does click, the trouble is in the motor or its connecting wires.

(a) **SWITCH AND RELAY TEST.** Check the voltage at the hot terminal (connected to black wire with white band) of the toggle switch (fig. 14). No voltage at this point indicates defective wiring between the switch and the circuit breaker (control circuit). Repair or replace the wiring. If voltage is available, install a jumper wire from the hot lead of the toggle switch to one of the F terminals of the relay. If the relay now clicks, replace the switch. If the relay does not click, ground the other F terminal of the relay and repeat the test. If the relay still does not click, replace the relay.

(b) **TESTING MOTOR AND CONNECTING WIRES.** Check for voltage at the B terminal of the relay (fig. 14). No voltage at this point indicates defective wiring between the relay and the circuit breaker (power circuit), or between the two relays (red with blue band). Repair or replace the wire. If voltage is available, check the green wire between the relay and the motor. Repair or replace wiring as necessary. If the unit still does not operate, repair or replace the motor.

(3) **REGULATOR OPERATES IN ONE DIRECTION ONLY.** If a regulator operates in only one direction, repair or replace the wire between the switch and the relay F terminal that applies to the direction in which the motor does not rotate. If the unit still does not operate, follow the instructions given in "(a) Switch and Relay Test" as outlined under "(2) One Regulator Inoperative." If this procedure does not correct the trouble, check the condition of the two field wires (one red, one yellow) between the relay and motor. Repair or replace as necessary. If the regulator still operates in only one direction, one of the motor field coils is open. Replace the motor.

(4) **REGULATOR OPERATES OPPOSITE TO SWITCH.** If the horizontal regulator moves forward when the switch is pushed backward (or visa versa), the wires between the switch and the horizontal motor relay are crossed. Similarly, if the vertical regulator moves up when the switch is pushed down (or visa versa), the wires between the switch and the vertical motor relay are crossed. Connect the wires to their proper terminals as shown in fig. 14.

(5) REGULATOR OPERATES SLUGGISHLY.

Check the screw jack and seat track mechanism for bind, and correct if necessary. Inspect all parts of the circuit for broken wires. Repair or replace defective wires. Make certain that all connections are tight and that there is no paint under wire terminals where they attach to the car body.

If the above measures do not correct sluggish operation, check the motor for worn brushes as follows.

Remove the motor, and check the motor no load current draw. Remove only the motor ground lead, and place the ammeter in series with the lead and ground. Operate the toggle switch, and observe the current. With no load, the current draw should be approximately 8-10 amperes at 12 volts. Worn or dirty brushes are indicated by low current. In such a case replace the motor.

d. Parts Replacement.

In figures 11, 12 and 13, the power seat assembly is removed from the car and disassembled from the seat frame for illustration purposes only. It is not necessary to remove the seat assembly from the car in order to replace either the horizontal or vertical regulator assembly, motor or relay. These parts can be removed from behind and underneath the front seat.

When replacing any part or assembly, it is important that any electrical wires, which are disconnected for removal purposes, be connected to their proper terminals.

NOTE: *Before replacing any of the following parts, run the seat to the extreme rearward and downward positions in order to relieve the assist springs.*

(1) REGULATOR ASSEMBLIES. When replacing the horizontal regulator, remove the left seat side shield (four attaching screws), remove the nut and bezel that retains the control switch to the side shield, and remove the switch from the shield. If the vertical regulator is to be replaced, remove the right seat side shield. Disconnect the assist spring (left for horizontal regulator, right for vertical regulator) by using a stiff wire with a loop on the end. Hook the loop of the wire to the rear loop of the spring and pull the spring back so as to disengage it from the arm and link assembly (fig. 11 or 13). Disconnect the motor ground wire at the bullet connector and disconnect the three wires (cable to relay) from the relay. Drive the rolled attaching pin from each end of the regulator assembly with a $\frac{1}{4}$ x 12 drill rod (figs. 11 and 12 for horizontal regulator, fig. 13 for vertical regulator). Remove the regulator, motor, and relay as one assembly.

To install, attach the regulator to the two mounting brackets with the rolled pins. Connect the wires to

the relay and motor, and test the seat operation. Hook one end of the spring to the forward end of the seat track mounting bracket, hook the looped wire to the other end of the spring, and pull the spring back so that it will hook around the arm and link assembly (figs. 11 and 13). Install the side shield (four attaching screws). With the horizontal regulator, install the control switch to the side shield with the bezel and attaching nut.

(2) RELAYS. Remove the regulator and motor assembly to which the relay is attached. Disconnect the motor to relay wires and remove the relay from the motor (two attaching screws). Mount the replacement relay to the motor, connect the motor-to-relay wires, and install the motor, relay, and regulator assembly to the seat.

(3) MOTORS. Remove the regulator assembly to which the motor is attached. Remove the two nuts that retain the motor to the regulator assembly and remove the motor from the regulator. Remove the (rubber) regulator drive coupling and the relay from the motor and install them on the replacement motor. Install the motor and rubber coupling to the regulator shaft, and secure the motor to the regulator bracket with two retaining nuts. Install the relay, motor and regulator assembly to the seat.

(4) REGULATOR SHAFT, GEAR OR HOUSING ASSEMBLY. Remove the regulator assembly from the seat and remove the motor and relay assembly from the regulator. Place the regulator assembly in a bench vise having soft jaws to retain the jack screw. Remove the regulator gear housing assembly (five retaining screws). Remove the shaft gear retaining nut from the shaft.

Place the assembly in a press, and press the shaft assembly from the gear and housing assembly. Remove the spacer assembly from the shaft, and remove the gear and key from the housing.

To assemble replacement parts, install the spacer assembly on the shaft, and press the shaft assembly into the housing. Position the housing and shaft assembly in a vise, set the key in the shaft keyway in the housing, and install the gear on the shaft. Install the gear retaining nut to the end of the shaft. Apply Lubriplate to the gears, and install the housing cover (five retaining screws).

Install the motor and relay assembly to the regulator, then install the regulator assembly to the seat.

e. Major Assembly Replacement.

Replacement of either the seat frame or the seat track assembly requires removal of the entire power seat assembly from the car.

NOTE: Before removing the assembly, be sure to run the seat to the extreme forward position in order to expose the Phillips head mounting screws at the forward ends of the upper tracks.

Disconnect the battery ground cable to prevent accidental operation. At each regulator motor, disconnect the motor ground wire at the bullet connector and disconnect the three wires (cable-to-relay) from the relay.

Remove the two front seat shields. Remove the control switch from the left hand shield. Loosen and remove the seat track mounting bracket stud bolts and nuts from the under side of the floor pan (fig. 12). Remove the seat track assembly (with seat frame attached) from the vehicle.

Remove the rolled pin that attaches the horizontal regulator jack to the bracket on the seat frame (fig. 12). At both right and left seat tracks, remove the Phillips head screw and the stud nut that attaches the upper track to the seat frame (fig. 12). Remove the seat frame from the seat track assembly.

Attach the seat track assembly to the seat frame by installing a Phillips head screw at the forward end of each upper track and a stud nut at the rear end of each upper track (figs. 12 and 13). Position the horizontal regulator jack to the bracket on the seat frame and install the rolled type attaching pin. Lift the power seat assembly into the vehicle and connect the motor and relay wires. Align the holes in the seat track mounting brackets with the holes in the floor pan, and install the mounting studs and nuts from the under side of the floor pan.

3. CONVERTIBLE TOP

The top on the Convertible is operated by an electric-hydraulic system and is controlled by a switch on the instrument panel. Satisfactory top operation depends on the hydraulic system, the electrical system, and the alignment of the top itself. When performing service operations, it is advisable to remember that each of these factors is affected by the other two.

This section explains the principles of top operation and outlines service procedures for hydraulic system maintenance, electrical trouble shooting, and top alignment.

a. Operating Principles.

The power system consists of an electric motor, a hydraulic pump, and two hydraulic cylinders. The motor and pump assembly are mounted on the floor

under the left side of the rear seat. The hydraulic cylinders are accessible after the rear seat back and quarter trim panels have been removed as shown in fig. 15.

The motor drives the hydraulic pump. When the top is being lowered, hydraulic fluid is pumped, through the hydraulic lines, into the upper ends of the cylinders. The hydraulic fluid exerts a pressure on top of the piston in each of the two cylinders, and the pistons are forced downward. The downward movement of the pistons displaces the fluid contained in the lower portions of the cylinders. The fluid displaced in this manner flows through the return lines, attached to the lower ends of the cylinders, to the vacuum side of the pump. The fluid then passes through the internal rotors of the pump and into the pressure side of the pump. Excess fluid is allowed to return to the reservoir through a check valve in the valve housing.

When the top is being raised, the flow of the fluid is reversed.

The various units that make up the power system (fig. 16) are described in the following paragraphs.

(1) **MOTOR AND PUMP ASSEMBLY.** A 12-volt direct current motor is used to drive the pump. The motor is reversible so that the pump can be driven in either a clockwise or counterclockwise direction. One end of the motor armature shaft is supported by a bushing in the end cover; the other end by a bushing in the center of the pump housing. The pump housing is attached to the motor frame by two through bolts from the end cover.

The outer rotor fits into the pump housing, and the inner rotor revolves within the outer rotor. The pump is connected to the armature shaft by means of a drive ball located in a hole in the end of the armature shaft. The drive ball fits into a groove in the inner rotor.

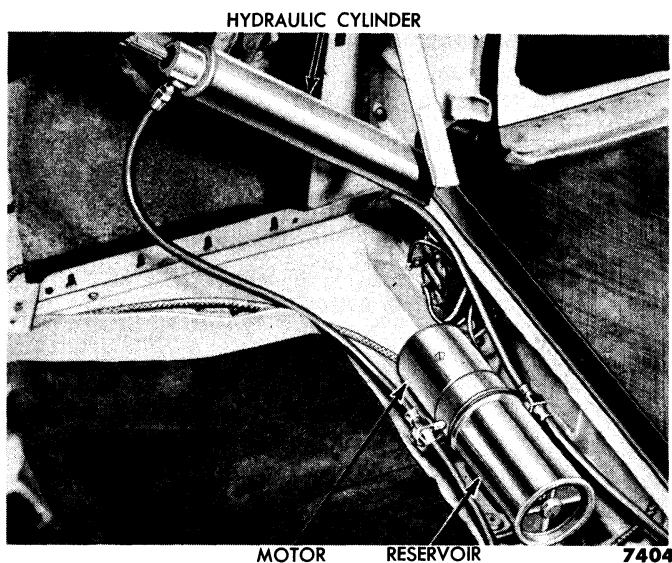

Fig. 15—Convertible Top Power Units

The valve housing is mounted to the pump body by five mounting bolts. The reservoir is attached to the valve housing by a center bolt which engages threads that are cut in the center of the valve housing. The reservoir is sealed at each end with a neoprene "o" ring.

Hydraulic pressure is created by the rotation of the internal rotor gears, and is exhausted through one of the two ports in the pump housing. Since the motor is reversible, either port may be on the vacuum or pressure side of the pump, depending on the direction of pump rotation. When the pump rotors turn, hydraulic pressure is created through one side of the pump while the other side of the pump becomes the vacuum side.

Two small check valves are seated in the valve housing and are held in place by a fulcrum and lever-type retainer. The vacuum created on the inlet side of the pump pulls the ball against its seat and thus cuts off the reservoir from the inlet side of the pump. This seating action of the ball at the inlet side permits the ball on the other end of the fulcrum to raise off its seat in the outlet side of the pump. Thus, at the beginning of pump rotation, fluid from the reservoir can pass into the pressure side of the pump but is prevented from entering the vacuum side. Moreover, during rotation, excess fluid can pass from the pressure side back to the reservoir. When pump rotation is reversed, the pressure and vacuum sides are reversed; and the check balls and fulcrum act to make the pressure reversal practically instantaneous.

(2) **TOP OPERATING CYLINDERS.** The operating

cylinders are of tubular construction and are fitted at each end with crimped-in die castings, together with synthetic rubber seals which form a fluid tight assembly. The lower casting forms a yoke which is attached to the floor bracket by means of a clevis pin and key. The upper casting provides a bearing for the piston rod and a cavity for the synthetic rubber seal and felt. These parts are held fast by means of washers and snap rings. The upper and lower ends of the cylinders are provided with threaded holes for the fluid line connections. Each cylinder is replaced as a unit.

(3) **CONTROL SWITCH.** The control switch is mounted underneath the left side of the instrument panel. The switch is a three-way switch and is normally in the center "off" position. The switch operates the motor when the switch control knob is moved to the extreme "in" or "out" position.

b. Hydraulic System Maintenance.

The fluid in the reservoir should be checked at 5,000 mile intervals. If additional fluid is needed, add only genuine Ford hydraulic brake fluid.

If proper top operation requires frequent addition of fluid, cylinder leakage is indicated. The cylinders are serviced as complete assemblies.

(1) **FLUID LEVEL CHECK.** Remove the rear seat cushion, and loosen the filler plug in the end of the reservoir (fig. 15). Operate the top three times to bleed all the air from the system.

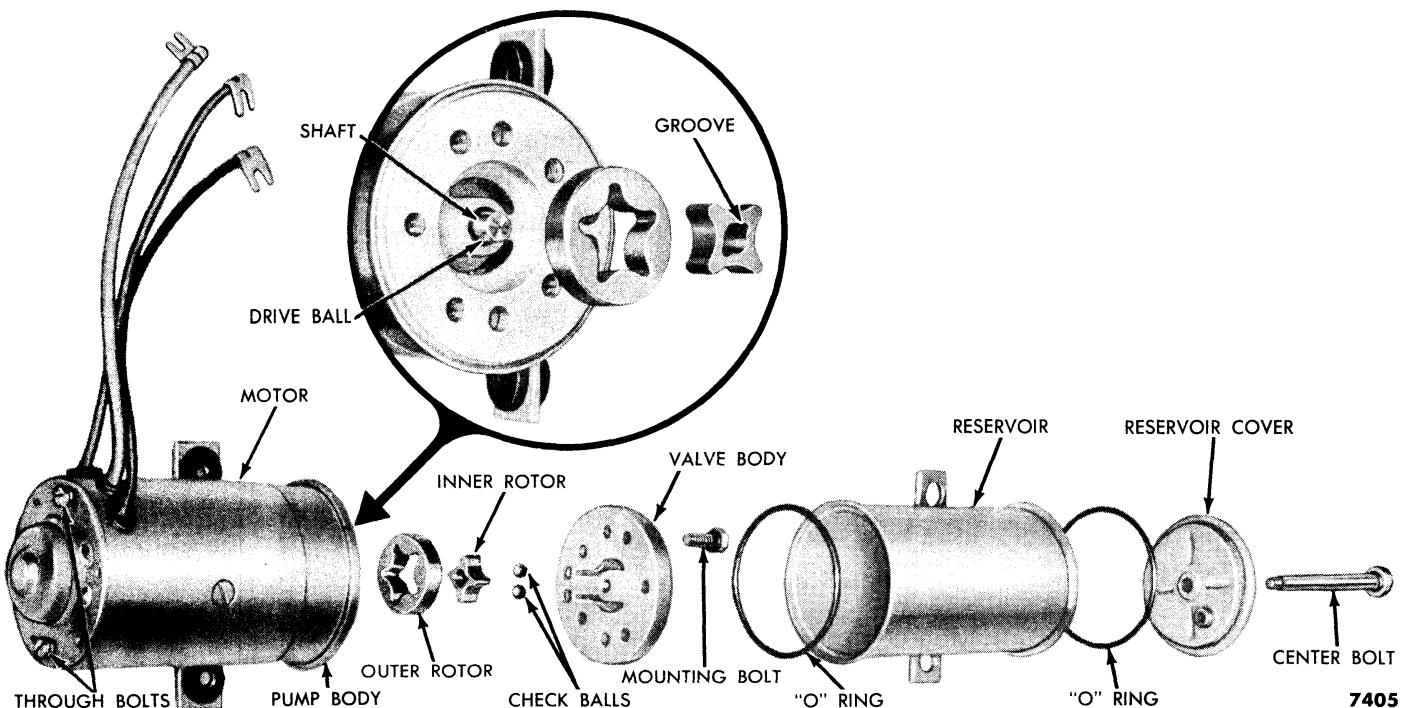

Fig. 16—Hydraulic Pump, Reservoir and Motor

NOTE: Check the fluid level with the top in the “up” position. Remove the filler plug.

If the hydraulic fluid does not run from the filler hole, add enough hydraulic brake fluid to raise the level to the edge of the filler plug hole.

NOTE: If removal of the reservoir is necessary, always be sure to replace the reservoir cover so that the reinforcement ridges are positioned horizontally and vertically with the filler plug at the top.

(2) **CYLINDER REPLACEMENT.** Disconnect the battery cable to prevent accidental operation of the top. Remove the rear seat and seat back. Remove the quarter trim panel. Disconnect the hydraulic lines at the upper and lower ends of the cylinder. Remove the cotter pin and clevis pin that secure the upper end of the piston to the rear arm assembly. Remove the cotter pin and clevis pin that secure the lower end of the cylinder to the floor pivot bracket, and remove the cylinder assembly.

To install the cylinder assembly, position the cylinder on the floor bracket with the inlet and outlet holes of the cylinder toward the floor. Install the clevis pin and cotter pin to secure the cylinder assembly to the floor pivot bracket. Line up the piston rod with the top arm assembly, and install the clevis pin and cotter key. Connect the hydraulic lines to the cylinder.

Connect the battery cable and check the top operation. Before installing the quarter trim panel, check for leaks at the connections. Install the quarter trim panel, seat, and seat back.

NOTE: If necessary, bleed the system and fill the reservoir to the proper level after replacing the cylinders.

c. Electrical Trouble Shooting.

Before electrical trouble shooting procedures are considered, check all pivot points of the top for freedom of movement. If any pivot points of the top are binding, relieve all binding conditions before proceeding with any further trouble shooting.

Check the time required to raise and lower the top. A properly charged hydraulic system will operate from up to down or vice versa in approximately 12 to 15 seconds. In cases where the unit is slow or sticks in operation, it may be that the column of oil is broken by air. If such a condition exists, bleed the hydraulic system before checking the electrical system.

If the top does not operate when the control switch is closed, a current draw and voltage drop test should be performed. Disconnect the heavy black wire from the circuit breaker located under the instrument panel (fig. 17). Connect the ammeter negative lead to the black wire and the positive lead to the circuit breaker terminal, then operate the top control switch. The normal current draw should be approximately 20-30 amperes running, and 35-45 amperes in the top stall condition with a voltage reading of 9-10.

An excess of 75 amperes indicates a frozen hydraulic pump or top lifting cylinders. A low amperage draw, with the motor running free and no indication of top movement, usually indicates a defective hydraulic

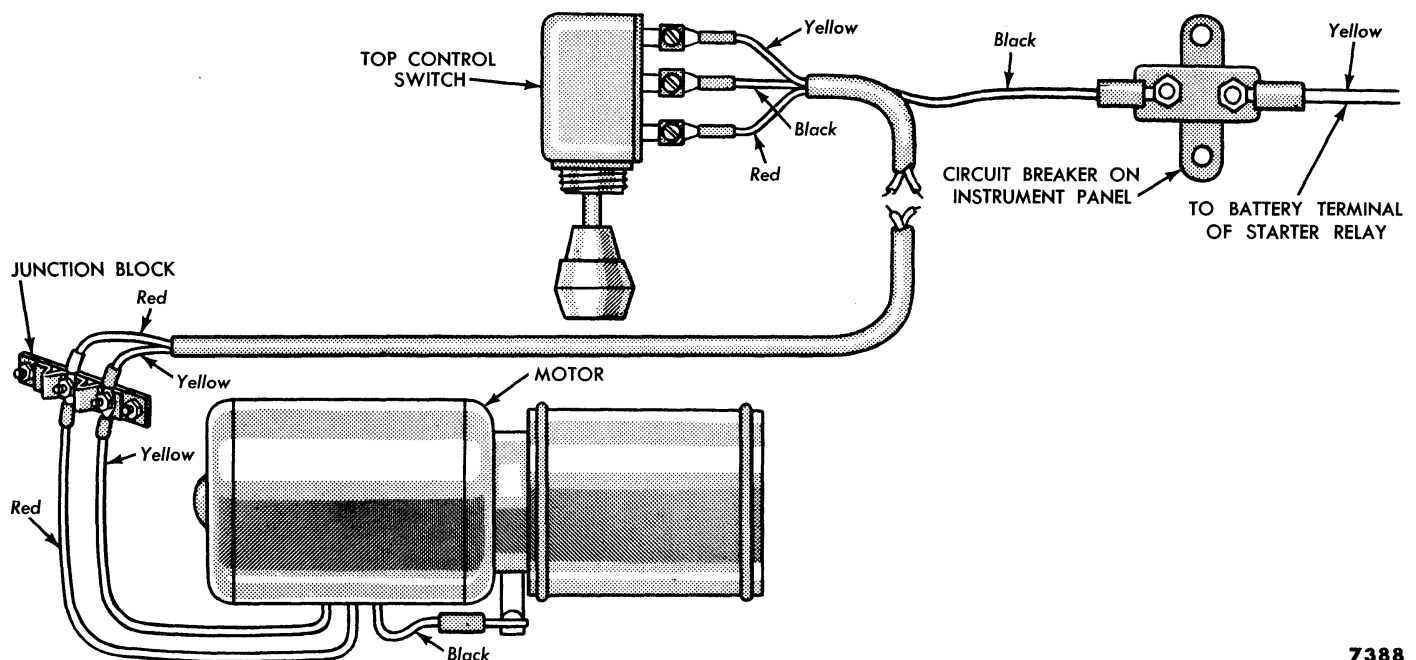

Fig. 17—Convertible Top Electrical Circuit

pump or insufficient fluid in the reservoir.

If no current is indicated, and the top does not operate, check the connection of the yellow lead from the battery side of the starter relay to the circuit breaker. If the wire is broken or frayed, replace the lead and attempt top operation. If the top is still inoperative, place a jumper wire across the terminals of the circuit breaker and close the switch. If the top then operates, replace the circuit breaker.

For further test procedures of an inoperative top, remove the rear seat cushion and inspect the electrical connections at the junction block and the motor ground lead for tightness. Also, check the three switch leads for tightness.

If the top is still inoperative after all the foregoing tests have been made, the difficulty may be in the control switch or the motor.

To determine which is at fault, place a jumper wire between the center terminal of the control switch (black wire) and one of the other two switch terminals (red or yellow wire) (fig. 17). If the top now operates, replace the control switch. If the top does not operate, replace the motor.

d. Top Alignment.

Before attempting to align the top, it should be operated to determine if any of the linkage is bent or binding. Faulty linkage should be replaced or freed from binds. All pivot points in the top linkage should be lubricated periodically with a few drops of light engine oil.

NOTE: *After obtaining proper top alignment, check and if necessary, adjust the door and quarter windows to assure proper fit along the top side rails. Do not attempt to adjust the windows if the top is misaligned.*

(1) **HEADER ADJUSTMENT.** This adjustment provides fore and aft movement of the top header to maintain alignment along the front edge of the header with relation to the windshield frame (fig. 18). The header adjustment also eliminates excessive slack in the top material between the header (number one bow) and the number two bow.

To make the adjustment, unfasten the two toggle clamps, and raise the top slightly above the windshield frame to relieve the strain on the top fabric. Remove the weatherstrip and retainer from the front side rail assembly.

The screws that attach the header to the side rail move in elongated holes (fig. 18). Loosen the nuts, and shift the header bracket either forward or backward in the elongated holes to align the header with the windshield frame or to remove excess slack from the top material. Tighten the screws after making the adjust-

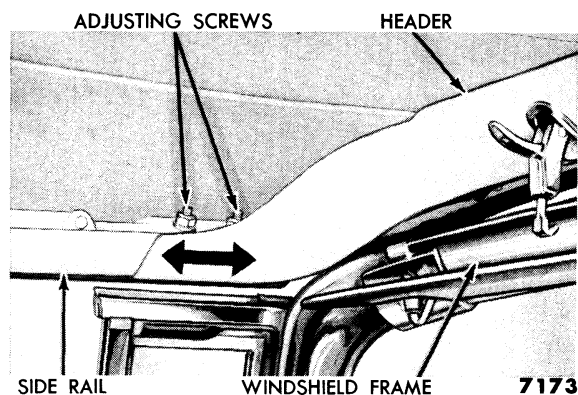

Fig. 18—Top Header Adjustment

ment. Install the weatherstrip retainer. Install the weatherstrip in the retainer, then adjust the dowel plate and toggle clamp.

(2) **TOGGLE CLAMP AND DOWEL PLATE ADJUSTMENT.** The toggle clamps are mounted on the top header (fig. 19). The hooks on the toggle clamps engage matching holes in the toggle clamp lock plates which are mounted in the windshield frame.

The toggle clamp hooks are adjustable up or down. This adjustment is provided to maintain a tight seal along the front edge. Before making this adjustment, visually inspect the front edge of the header to determine if the header is sealing properly along the top of the windshield frame.

The seal can also be checked by inserting a piece of paper between the header and windshield frame. Release the top, insert the paper, then lock the top. If the paper pulls out freely, an adjustment is necessary. Make the paper test at both ends. It is not necessary to adjust both sides. Adjust only the side which is not sealing properly.

If adjustment is necessary, loosen the small set screw with an Allen wrench as shown in fig. 19. Lengthen or shorten the hook until the pressure of the header against the windshield frame is equal on both sides, and a good seal exists between header and windshield.

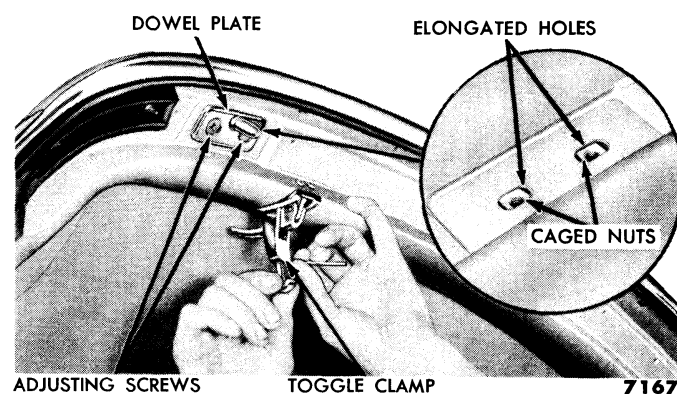

Fig. 19—Toggle Clamp and Dowel Plate Adjustments

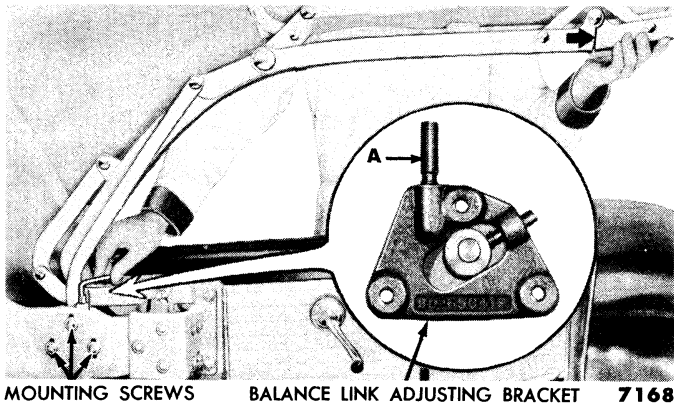

Fig. 20—Balance Link Bracket Adjustment For Sag or Crown in Side Rail

CAUTION: When tightening the Allen set screw, be sure to seat the set screw into the slot provided on the toggle hook.

The lock dowels are integral with an adjustable plate and are mounted in the top header (fig. 19). Corresponding dowel guides are mounted in the windshield frame. Each dowel plate is adjustable to maintain the dowel in alignment with its respective guide. The dowel plate can be shifted forward, backward, or laterally because the plate retaining screws engage floating caged nuts in elongated holes (insert, fig. 19).

After making any other top adjustment, check the alignment between the dowels and guides. If adjustment is necessary, loosen the adjusting screws, move the plate to the required position, then tighten the screws.

(3) BALANCE LINK ADJUSTMENT. The balance link adjusting bracket is mounted to the quarter panel by three screws (figs. 20 and 21). Two adjustments are provided at the bracket. One adjustment eliminates sag or excessive crown along the top side rail. The other adjustment permits the top to stack properly in the top well.

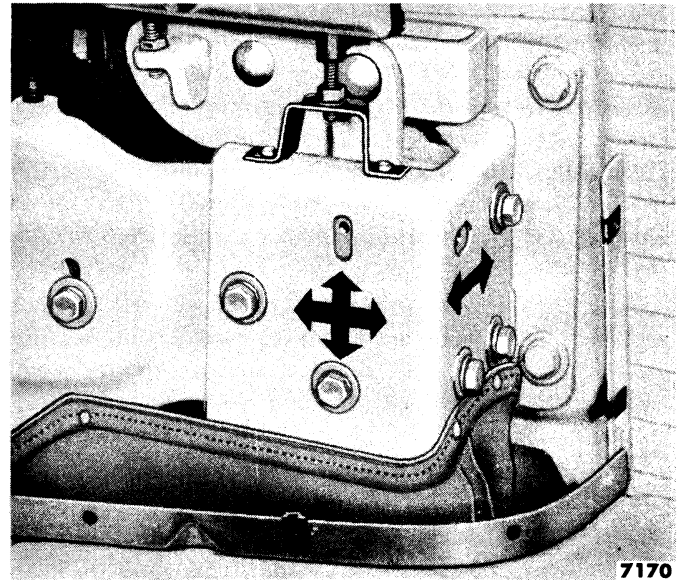

Fig. 22—Main Pivot Bracket Adjustments

If the top side rails are sagged or have excessive crown, loosen the three mounting screws at the balance link adjusting bracket. Turn the set screw "A" (fig. 20), clockwise if the side rails are sagged, or counterclockwise if the side rails are crowned. Tighten the cap screws securely after completing the adjustment.

For proper positioning of the top in the well, loosen the three mounting screws, and turn the set screw "B" (fig. 21). To stack the top lower in the well, turn the set screw clockwise. To stack the top higher in the well, turn the set screw counterclockwise. Tighten the three mounting screws after making the adjustment.

(4) MAIN PIVOT BRACKET ADJUSTMENT. The

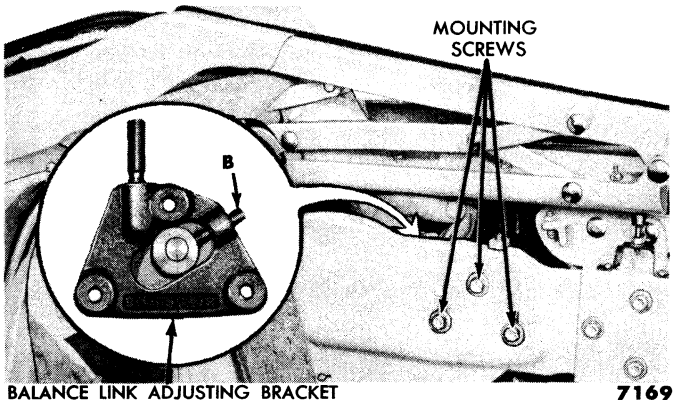

Fig. 21—Balance Link Bracket Adjustment for Stacking in Top Well

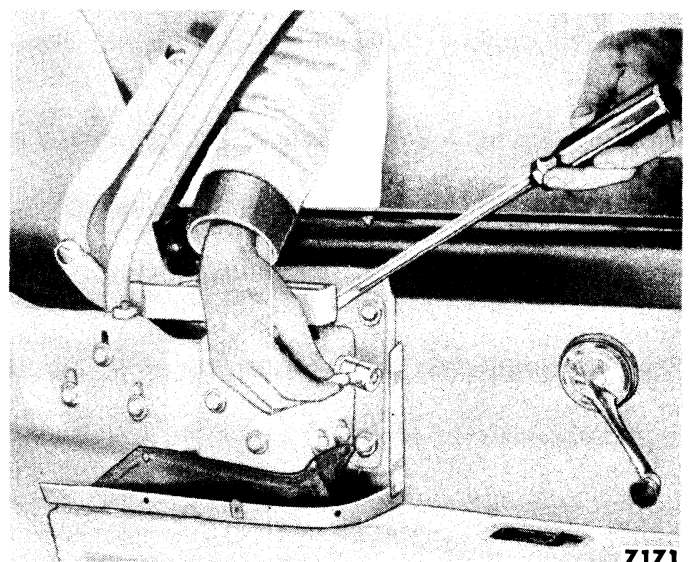

Fig. 23—Top Side Rail to Quarter Window Adjustment

main pivot bracket is mounted on the support by seven screws. Elongated holes, in both the support and the bracket, permit the bracket to be shifted vertically, horizontally, and laterally as indicated by the arrows (fig. 22).

If the complete top assembly requires shifting toward the front or rear of the body, loosen the mounting screws at both main pivot bracket supports. Shift the top assembly to the desired position, and tighten the mounting screws.

To adjust the top side rails toward or away from the quarter window, loosen the mounting bolts, and shift the main pivot bracket (fig. 23). If the quarter window binds as it is lowered along the rear side rail, raise the main pivot bracket just enough to eliminate the bind. If the glass run in the side rail does not line up with the quarter glass, shift the main pivot bracket in or out as necessary to center the glass in the run. Tighten the mounting screws. If necessary, repeat the adjustment at the main pivot bracket on the opposite side.

(5) **STOP SCREW ADJUSTMENTS.** A rubber

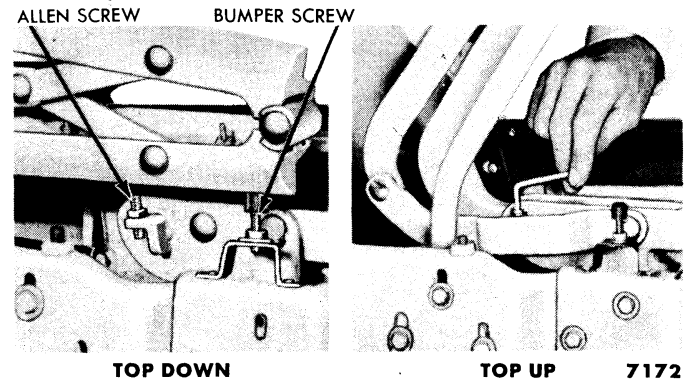

Fig. 24—Stop Screw Adjustments

bumper screw and an Allen screw are provided to support the side rails of the folded top as it stacks in the well (fig. 24). To adjust the stop screws, first determine how much they should be raised or lowered when the top is down; then raise the top. With the top in the "up" position (fig. 24), loosen the lock nuts, and turn the screws up or down as required. Tighten the lock nuts and lower the top.

4. THUNDERBIRD TOP ADJUSTMENTS

Before attempting adjustment of the top assembly, be sure to complete all door window adjustments as outlined in Chapter II, Section 5. Make all Thunderbird top adjustments with the upper portion of the top mechanism assembly disconnected from the storage link tie bar (fig. 25, View A). Disconnect the tie bar by removing the cotter key and pivot pin. Free the header bow of all trim material and raise the window to the full closed position. Loosen the blind nuts that secure the header bow to the front side rails (fig. 25). Now proceed with the adjustments in the order given.

a. Adjustment of Toggle Clamps to Header Bow.

Loosen the adjusting screw shown in View C fig. 25, and revolve the toggle hook in or out to obtain a 0.38-inch parallel spacing between the top of the windshield header and the bottom of the header bow as shown. Be sure to set the adjusting screw in the slot of the toggle hook, then tighten the adjusting screw.

b. Adjustment of Toggle Clamps to Upper Back Panel.

Loosen the adjusting screw in View D, fig. 25. Revolve the two rear toggle clamp fasteners in or out to obtain a 0.25-inch parallel spacing between the top of the upper back panel and the bottom of No. four bow as shown in View E, fig. 25. With the handle in the locked position set the adjusting screw (View D) in the slot of the clamp fastener, then tighten the screw.

Loosen the adjusting screw in View A, fig. 25 and revolve the toggle hooks of the two forward toggle clamps in or out to obtain a 0.25-inch spacing between the top of the upper back panel and bottom of No. four bow at each side (typical of View E). With the toggle clamp in locked position, set the adjusting screw in the slot of the clamp stud, then tighten the adjusting screw.

c. Adjustment of Rear Side Rails to Door Windows.

First, the entire top assembly is adjusted forward or backward to an established dimension between the lower end of the rear side rails and the door windows, then each rear side rail is adjusted in or out to obtain the correct parallel spacing between side rail and window along the entire length.

(1) **TOP ASSEMBLY.** Unlock the forward toggle clamps and loosen the hex nut at the underside of each rear toggle assembly (View D, fig. 25). Move the top assembly forward or backward until a 0.43-inch dimension is obtained between the door windows and the rear side rails at the lower end. Lock the forward toggle clamps, and tighten the hex nuts.

(2) **SIDE RAIL.** The rear side rail is provided with an adjusting screw and lock nut at each end (fig. 25). Loosen the locknuts and turn the adjusting screws in or out until a 0.43 inch constant parallel spacing is obtained between the window and rear side rail along the entire length.

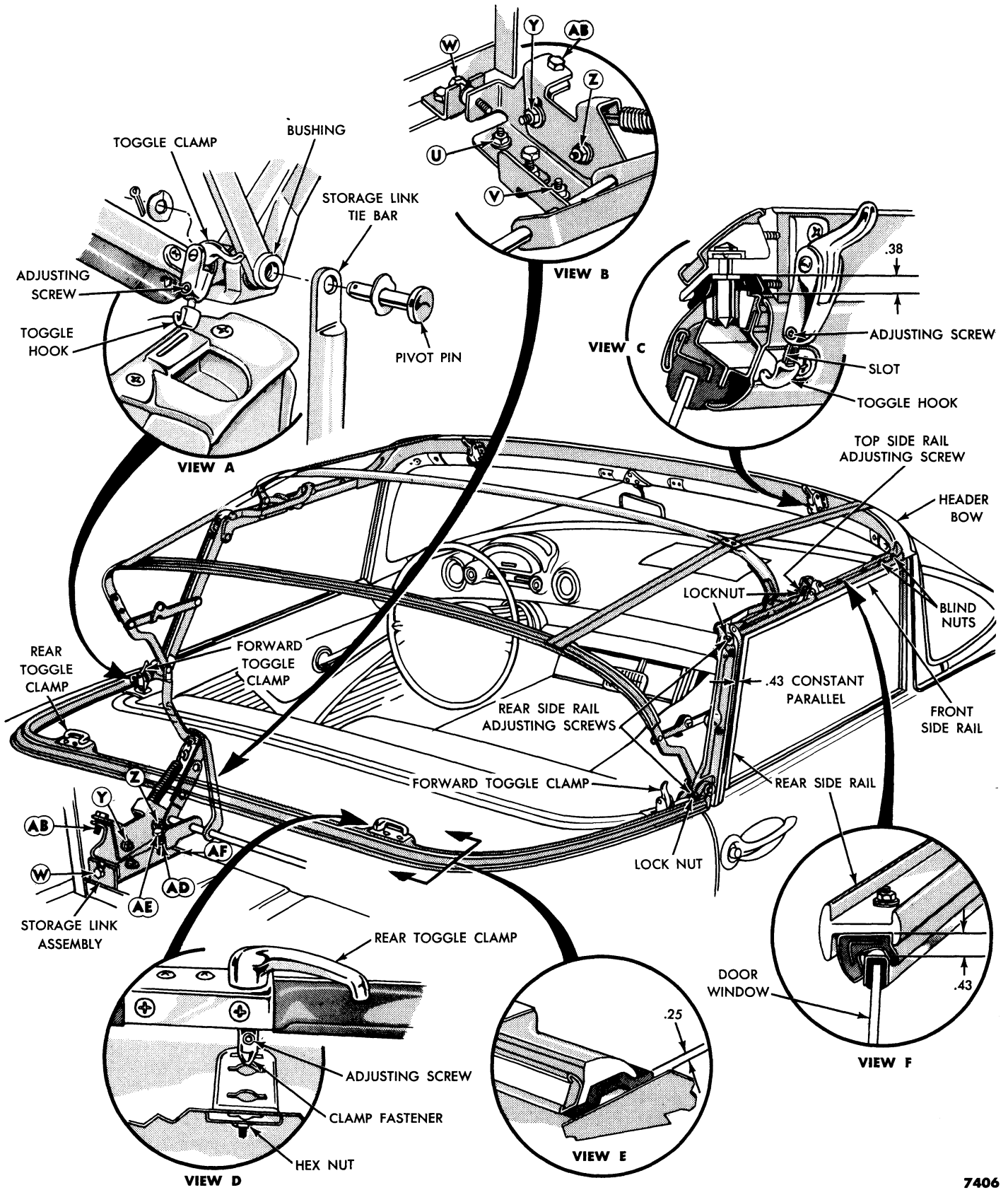

7406

Fig. 25—Thunderbird Top Adjustments

NOTE: *After adjusting the rear side rails to the door windows, tighten the two blind nuts that secure the header bow to the front side rails.*

d. Top Side Rail Sag and Crown Adjustment.

To eliminate sag or crown of the top side rail assembly at the top edge of the door window, loosen the lock nut and turn the top side rail adjusting screw (fig. 25). Turn the adjusting screw down to eliminate sag in the side rail. Turn the adjusting screw up to eliminate crown in the side rail. After adjustment tighten the lock nut.

e. Adjustment of Top Mechanism to Storage Link Assembly.

The purpose of this adjustment is to align the

storage link tie bar with the bushing in the top mechanism so that the pivot pin can be installed (View A, fig. 25). The various lock nuts and adjusting screws are designated by letters and are illustrated in View B and at the storage link assembly in fig. 25. Loosen lock nuts "U" and "V," and turn adjusting bolt "W" in or out to align the storage link tie bar with the vertical center line of the bushing. Tighten lock nuts "U" and "V."

Loosen lock nuts "Y" and "Z" and turn adjusting bolt "AB" in or out to align the storage link tie bar with the horizontal center line of the bushing. Insert the pivot pin into position and secure it with washers and cotter pin. Tighten lock nuts "Y" and "Z" securely.

To secure the new adjustment, loosen lock nut "AD," turn adjusting bolt "AE" in or out to bring it in contact with bracket "AF", then tighten lock nut "AD."

5. CARE OF COUNTRY SQUIRE PANELING

The side panels and trim rails used on the Country Squire are of special construction and require special care. The side panels are metal, covered with wood-grained transfers. The fibre glass trim rails are also covered with wood-grained transfers.

The vehicle should be washed frequently to remove harmful road dirt. Procedures for washing, trim rail replacement, and the application of wood-grained transfers are given in this section.

a. Washing.

NOTE: *Never wipe the body with a dry cloth. This method of cleaning tends to rub dust particles into the finished surface and leave fine scratches.*

Flush off all loose dirt and other elements, then wipe the body panels and frames with a sponge and plenty of cold water. If desired, a mild detergent soap may be used. Rinse thoroughly with clear water, then wipe dry with a damp chamois. A damp chamois may also be used to clean the inside trim.

b. Fibre Glass Trim Rail Replacement.

The trim rails are serviced with the wood grained transfers and varnish already applied. To remove the body side fibre glass trim rails, first remove the interior side trim. The cap over each oval head screw must be removed to gain access to the screws. Remove the oval head screws, then remove the trim rail assembly (fig. 26). Some of the rails consist of more than one piece; therefore, when removing the oval head screws, make certain that all screws that secure the particular assembly to the body are removed.

The fibre glass rails on the tail gate are serviced as an assembly. The method of attachment is slightly different than that used on the body side trim. To remove the fibre glass trim from the tail gate, remove

the cap screws from the inner and outer sides. It is not necessary to remove the blind sleeve nut unless the trim is to be replaced. To remove the blind sleeve nut, install the cap screw in the nut, then carefully tap the head of the cap screw to force the sleeve nut out of the fibre glass.

When installing the body side trim rail, apply sealer (M-5398-B) around each mounting hole. Install the seal retainer, oval head screw, and cap.

c. Application of Wood Grained Transfers to the Panels.

Mahogany grain transfers are available for application to the panels. Other materials necessary to apply the transfers are a bonding coat (M-4584), water soluble solution (M-5412), and clear spar varnish (M-3720).

To refinish a damaged metal station wagon body, after all damaged metal repair work has been completed, first "mask off" the repair work area where the transfer is to be applied, then prime-coat all metal surfaces. When it is dry, sand the surface to prepare it for a new transfer application.

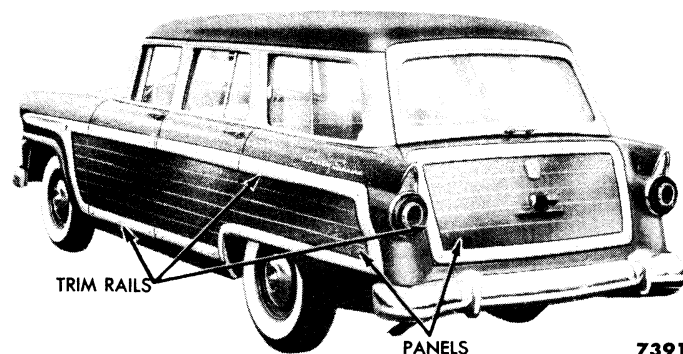

Fig. 26—Country Squire Trim Rails and Paneling

Spray the primed surface of the repair area with transfer bonding coat (M-4584). This coat acts as a binder or base for the transfer adhesive.

Be sure to use the bonding coat as recommended. Allow the bonding coat to air dry for approximately one hour. If heat lights are used, allow twenty minutes drying time. Heat lights should be located nine inches from the body panel. When dry, lightly wet sand the bonding coat, and wipe it clean.

To determine the size of transfer to be used, make a paper template to fit the damaged area, then apply the template to the selected portion of the new transfer sheet and cut accordingly.

Allow about ½ inch of extra material around the edge of the transfer to allow for any variation in matching and trimming.

For cementing transfers to body panels, use Solution M-5412 and 80% water. This diluted solution permits shifting the transfer after it has been applied so that the graining can be matched. Be sure to dilute the adhesive as specified.

Before applying the transfer, apply a trial sample of transfer and solution to a piece of body metal or old fender, until familiar with the proper solution and method of application. If the piece of transfer cannot be pulled off the panel after two minutes, the transfer solution is too strong and must be diluted with more water.

Immerse the cut transfer in lukewarm water for approximately one minute to loosen the paper backing. The paper backing must not be removed until after the

transfer has been applied to the body.

Next, make up a small cheese cloth pad and dip the pad into the M-5412 solution, diluted as explained. Apply the pad, saturated with solution, to the body panel where the transfer is to be applied.

CAUTION: *Any excess adhesive solution that accidentally runs down onto adjacent body panels must be wiped away immediately.*

Place the wet transfer on the body panel, paper side out. After carefully adjusting the transfer to match the graining character on the adjoining original finish, carefully remove the paper backing.

Sponge all areas of the applied transfer with clean water to remove all traces of paper backing adhesive. Once the operation of applying a transfer to the body panel is started, it must be followed through to completion before the adhesive begins to set.

After the transfer is in place, remove all air bubbles and wrinkles with a rubber "Squee-gee." Use an overlapping stroke to level off the transfer, working from the center or high point of the metal panel towards the outer edges. Use plain water as a lubricant for the "Squee-gee."

Wash the transfer carefully with clear water and dry it with a chamois. Pierce any blisters or small air bubbles as they appear, then press the pierced area with the fingers to squeeze out air and excess solution. If heat lights are used for drying, place these lights approximately nine inches from the panel and maintain a temperature of 160 degrees for approximately twenty minutes.

6. CROWN VICTORIA TRANSPARENT TOP

The transparent top is a plastic insert installed in the forward portion of the roof. The roof insert material is chemically known as "methyl methacrylate" and is commonly referred to as "plexiglas."

This section outlines the procedures for replacement and maintenance of the insert as well as for removal and installation of the sun shade curtain.

a. Insert Removal.

From inside the car, remove the sun visor and rear view mirror brackets, remove the garnish mouldings from all four sides of the insert, and remove the interior molding that is installed next to the rear edge of the roof insert (fig. 27). This procedure will relieve the pressure from the lip of the rubber weatherstrip around the inside edges of the roof insert. Remove the inside quarter lock mouldings and the nuts that retain the outer quarter mouldings to the lock pillars. Remove the nuts and washers from the two end retainer assemblies ("B" fig. 28) and from the eight intermediate retainer assemblies ("A" fig. 28). The intermediate

retainers hold the roof outside center moulding to the roof panel and to the outside edge of the insert. Also, remove the nuts and washers from the eight retainer assemblies that hold the windshield outside top moulding to the header ("C" fig. 28).

From outside the car, remove the retaining screws and the two windshield outside side mouldings (fig. 28). By prying the mouldings from the body, remove the windshield outside top mouldings, the two front roof side mouldings, the two side quarter lock mouldings, and the roof outside center moulding.

NOTE: *Care should be exercised when removing the mouldings to avoid damaging the mouldings and paint finishes. Use a shop towel beneath the instrument used for prying off the roof outer mouldings.*

Loosen the sealer between the weatherstrip and the outer edges of the roof panel with a putty knife, apply hand pressure on the inner side of the roof insert, and remove the roof insert and weatherstrip. The weatherstrip is placed around, and "lipped" over the edges of

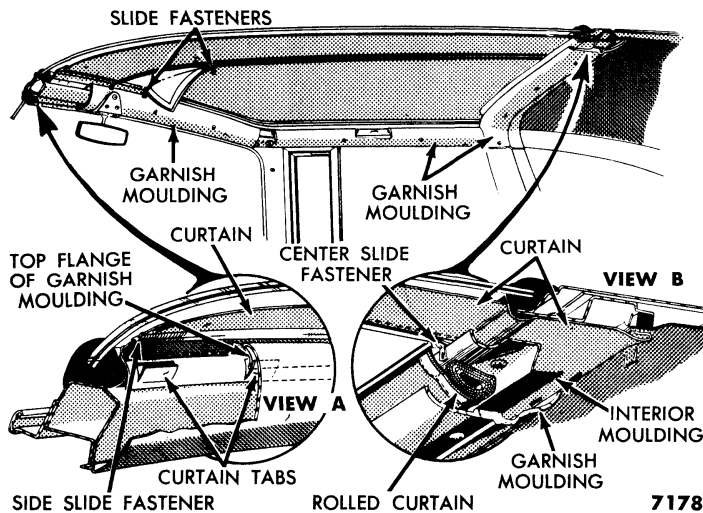

Fig. 27—Crown Victoria Inside Garnish Moulding and Sun Shade

the roof insert. To remove the weatherstrip, just pull it off the edges of the roof insert.

b. Installation.

Before installing the roof insert glass, clean all the old cement from the body flange and glass. Inspect the weatherstrip to make sure it is not damaged. Replace the weatherstrip if necessary.

Apply rubber cement sealer (8A-19552-B) in the channel of the weatherstrip, then stretch the weather-

strip around the glass. Apply sealer (8A-19552-B) around the roof panel, then set the roof insert and weatherstrip assembly in place. Make certain that the roof insert and weatherstrip are properly aligned with all sides of the roof panel.

Properly position the retainer assemblies in the roof outside center moulding, and install the moulding and retainers across the roof panel (fig. 28). Position the retainer assemblies in the windshield outside top moulding, and install the moulding and retainers to the windshield header. Install the nuts and washers on both the center moulding and windshield moulding retainers, and tighten the screws evenly along both mouldings. As the screws are being tightened, make sure the underside of the weatherstrip "lips" over the roof panel flange on all sides of the insert.

Install the two side quarter lock mouldings with retaining screws. Snap the two front roof side mouldings on the retainers, and install the retaining screws at the ends (fig. 28). Install the two windshield outside side mouldings and secure with retaining screws.

From inside the vehicle, install the inside quarter lock mouldings, and secure them to the lock pillars with retaining screws. Make sure the curtain is properly stapled to the tacking strip, stretch the rear end of the curtain taut around the lower lip of the weatherstrip, and install the interior moulding along the rear edge of the plastic insert ("B" fig. 27). Install the four

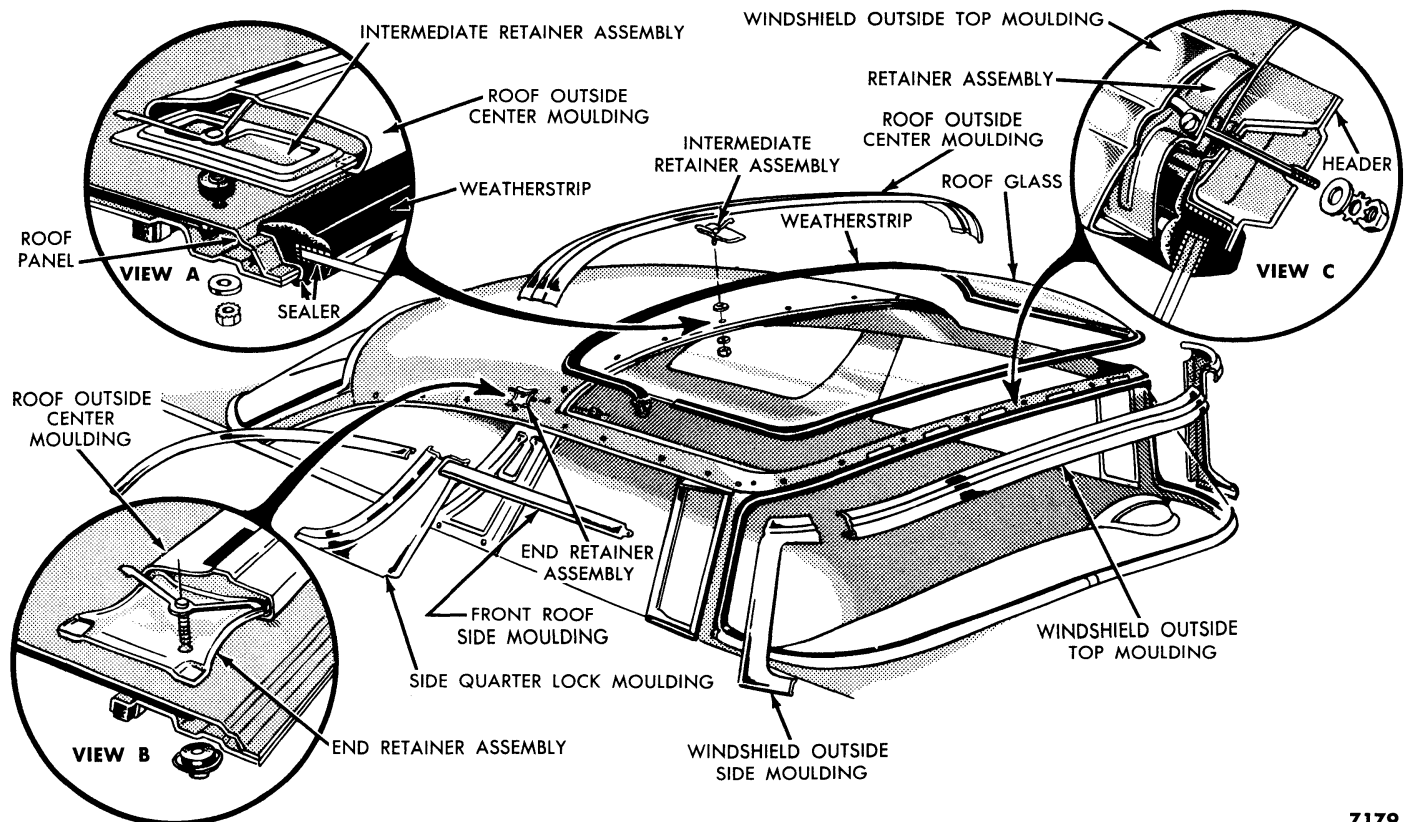

Fig. 28—Crown Victoria Transparent Roof Insert

garnish moulding strips and the sun visor and rear view mirror. When installing the front and side garnish mouldings, insert the cardboard tabs of the curtain assembly under the top flange of the garnish mouldings ("A" fig. 27).

c. Sun Shade Curtain.

The two curtain panels are stapled at the rear ("B" fig. 27) and assembled in place by three slide fasteners which come together at the front. The two side slide fasteners attach the front and sides of the panels to the curtain assembly which is retained in the garnish moulding by cardboard tabs ("A" fig. 27). The third slide fastener holds the two panels together at the center.

For storage of the curtain, open the three slide fasteners, roll the two curtain panels from the front toward the rear, and insert the panels into the roof center garnish moulding ("B" fig. 27).

d. Maintenance and Care of

Roof Insert.

Since the Crown Victoria roof insert is made of "plexiglas," certain precautions must be observed when cleaning the insert. Also, certain precautions must be observed when painting operations are involved, and definite procedures must be followed for polishing and rubbing out scratches that appear on the roof insert surfaces.

(1) **WASHING.** The roof insert should be washed by hand. Never use a brush. Use plenty of water with soap added, if necessary. If the roof insert is caked with mud or is excessively dirty, proceed as follows:

First, loosen and remove as much dirt as possible by flushing with water. Then use a sponge or grit-free cloth, with light hand pressure, to rinse off the roof insert.

(2) **POLISHING.** Before polishing, wash the roof insert to remove any loose dirt. Apply Lustur-Seal Haze Cream (AB-19530-A) according to the directions given on the container.

Lustur-Seal Haze Cream is also a cleaner and will remove road film, grease, oil, or sealer and rubber cement smears.

On new units, it is recommended that the roof insert be cleaned and polished with Lustur-Seal Haze Cream to remove smears.

(3) **HAIRLINE SCRATCHES.** Hairline scratches in the roof insert are usually the result of careless cleaning, such as wiping dirt off with a dry cloth or using a stiff brush.

Fine hairline scratches can be removed with Lustur-Seal No. 1 (AB-19520-A). Use a standard polishing wheel (1200-1750 r.p.m.) with a cotton flannel bonnet over the lambswool pad to polish out the hairline scratches. Then hand polish with Lustur-Seal Haze

Cream as a final operation.

(4) **HEAVY OR SEVERE SCRATCHES.** In some cases, heavy or severe scratches in the roof insert can be removed with a polishing wheel and Lustur-Seal No. 2 (AB-19520-B).

Severe scratches, such as those caused by the slip of a screwdriver or any sharp object, must be feathered out by sanding before proceeding with the polishing operation. After feathering out the scratches, use a standard polishing wheel, with a good grade of lambswool pad, and Lustur-Seal No. 2. Work the wheel back and forth, using slight pressure by holding the wheel flat against the surface.

After all scratches have been removed, use the same lambswool pad, with a cotton flannel bonnet installed over the pad, and again go over the entire roof insert with Lustur-Seal No. 1.

As a final polishing operation, apply Lustur-Seal Haze Cream (AB-19530-A) according to the instructions given on the container.

(5) **SANDING DEEP SCRATCHES.** If scratches are too deep to be removed with the polishing wheel, it will be necessary to use sandpaper.

Where sanding is required, start with the finest grade of sandpaper that will remove scratches or defects (no coarser than Grade 320). Wrap the paper around a hard felt or rubber block, and rub the area lightly using soap and water as a lubricant. The abrasive paper should be of the water proof type. Sand with a free, circular motion using a light pressure over the area. Initial sanding should be followed by similar treatment with progressively finer grades of sandpaper (Grades 360-A, 400-A, 500, and 600-A).

Wash the roof insert after each sanding operation. During each step, the scratches left by the preceding grade of abrasive will be removed. After feather sanding the scratches with 500 or 600-A sandpaper, proceed with the polishing wheel operation as for heavy or severe scratches.

The lambswool pad used with the polishing wheel must be of high quality. The cotton flannel bonnet, needed for applying Lustur-Seal No. 1, should also be of high quality and should fit the pad closely.

(6) **PAINT OVERSPRAY.** To remove paint overspray from the roof insert, use Lustur-Seal No. 1 (AB-19520-A) and a standard polishing wheel (1200-1750 r.p.m.) equipped with a lambswool polishing pad that is covered with a cotton flannel bonnet. After removing the overspray from the roof insert, polish the area, from which the overspray was removed, with Lustur-Seal Haze Cream (AB-19530-A) according to the directions on the container.

Other materials may be used in the procedure outlined above, but the materials mentioned do the job in the quickest time with the best results.

Part FIVE
MAINTENANCE AND SPECIFICATIONS

Chapter
I

Maintenance

Section	Page
1 Preventive Maintenance	353
2 Lubrication	355

The maintenance procedures given in this chapter cover all units on the car. Under normal operating conditions, these procedures will maintain the perform-

ance of the car at peak efficiency. Where severe or abnormal conditions exist, some of the procedures may have to be performed more often.

I. PREVENTIVE MAINTENANCE

Perform the following checks at the same time the car is lubricated. Repair or replace all defective parts. Perform seasonal operations that prepare the car for summer or winter twice yearly.

a. 1000-Mile Inspection Service.

Perform the following operations in addition to the 1000-mile lubrication service:

(1) **HOSES, BELTS, AND LINES.** Inspect the condition of the radiator hoses, drive belts, fuel lines, and hydraulic lines.

(2) **FUEL FILTER.** Remove and clean the fuel pump bowl on passenger cars. Install a new filter element.

On Thunderbirds, clean the fuel line filter bowl. Install a new filter element.

Repeat the above procedures each 4000 miles.

(3) **EXHAUST SYSTEM AND SPRINGS.** Check the exhaust system for loose connections and leaks. Check the exhaust thermostat shaft for free movement. Check the springs for broken leaves (or coils).

(4) **BATTERY TERMINALS.** Check and clean the battery terminals following the procedure given in Part One, Chapter I, Section 2, "Tune-Up."

(5) **BATTERY.** Fill the battery to the proper water level. Check the battery cell voltages with an expanded scale voltmeter. Charge the battery as required.

(6) **LIGHTS.** Check the condition and operation of the headlights, headlight dimmer switch, taillight, stoplights, panel, and interior lights.

(7) **TIRES.** Inflate the tires to the recommended pressures. Examine the tires for cuts, cracks, or unusual wear.

(8) **INTERIOR.** Clean the interior of the car.

b. 5000-Mile Inspection Service.

Perform the following operations in addition to the 5000-mile lubrication service:

(1) **CONVERTIBLE TOP LINKAGE.** Check the operation of the top mechanism and adjust as required.

(2) **DOORS.** Check all doors for alignment and adjust the striker plates. Clean the drain holes at the bottom of the doors.

(3) **WEATHERSTRIP AND RUBBER BUMPERS.** Replace missing or worn weatherstrips or rubber bumpers on the doors and hood.

(4) **WINDOW OPERATION.** Check the operation of all windows.

(5) **EXTERIOR SURFACES.** Inspect all exterior surfaces for rust and corrosion.

(6) **COOLING SYSTEM.** Test the concentration and level of the radiator coolant. If signs of excessive rust are apparent, drain and clean the cooling system with Cooling System Cleaner 1A-19527-A (Regular) or 1A-19527-B (Heavy Duty).

Inspect the radiator cap operation.

Check the condition of all hoses and tighten the connections.

(7) **DRIVE BELTS.** Inspect and adjust all drive belts.

(8) **REAR AXLE.** Tighten the differential carrier to housing stud nuts. Check the outside of the axle housing for lubricant leakage.

(9) **OIL PAN.** Examine the oil pan for leakage and tighten the screws to the specified torque if necessary.

(10) **STARTER MOTOR.** Tighten the starter motor mounting bolts (5-10 foot-pounds torque). Tighten the cable connections securely.

(11) **EXHAUST SYSTEM.** Tighten the exhaust pipe muffler brackets and clamps.

Tighten all exhaust manifold nuts and cap screws (23-28 foot-pounds torque), and, at the same time, examine the exhaust manifold for cracks or leaks.

(12) **FUEL SYSTEM.** Tighten the fuel tank hold down bolts and fuel line connections at the fuel tank.

Drain a quantity of fuel from the tank to remove any accumulation of water or sediment in the tank.

(13) **WHEEL NUTS.** Tighten all wheel nuts to 65-75 foot-pounds torque.

(14) **WINDSHIELD WIPERS.** Check the windshield wiper blades and windshield wiper operation.

(15) **BRAKES.** Remove one front drum and examine the brake lining. If the lining is worn to within $\frac{1}{32}$ inch of the rivet heads, reline the brakes.

If the brake lining is satisfactory, install the wheel and check the brake pedal reserve. Readjust all brake shoes when the pedal reserve is less than one-half the distance to the floorboard.

Check the brake pedal travel and adjust to $\frac{5}{16}$ - $\frac{7}{16}$ inch if required. If pedal operation is spongy, bleed the brakes, and fill the master cylinder with heavy-duty brake fluid.

(16) **TIRES.** Cross-switch the tires at 5000-mile intervals.

(17) **CLUTCH.** Check and adjust the clutch pedal free travel to $1\frac{1}{8}$ - $1\frac{3}{8}$ inches.

(18) **SPARK PLUGS.** Check and clean all spark plugs following the procedure given in Part One, Chapter I, Section 2, "Tune-Up."

(19) **COMPRESSION.** Test the compression of each cylinder following the procedure given in Part One, Chapter I, Section 2, "Tune-Up."

(20) **BATTERY.** Check the battery following the procedure given in Part One, Chapter I, Section 2, "Tune-Up."

(21) **WIRE CONNECTIONS.** Tighten the wire connections at the generator, the generator regulator, the coil, and the starting motor relay.

(22) **GENERATOR.** Test the generator output, and if it is below specifications, replace or rebuild the generator.

(23) **GENERATOR REGULATOR.** Test the cut-in voltage, reverse current, voltage regulation, and current regulation of the generator regulator. Adjust or replace the regulator if required.

(24) **GENERATOR CIRCUIT.** Test the generating circuit for excessive resistance and make all necessary corrections.

(25) **STARTER MOTOR CURRENT DRAW.** Check the starting motor current draw under load and no load. Rebuild or replace the starting motor if necessary.

(26) **IGNITION PRIMARY CIRCUIT.** Check the ignition primary circuit resistance and visually inspect the wires for faulty insulation or poor connections. Replace the wires, and tighten the connections as required.

(27) **DISTRIBUTOR.** Check the distributor following the procedure given in Part One, Chapter I, Section 2, "Tune-Up."

(28) **IGNITION TIMING.** Set the ignition timing.

(29) **SPARK INTENSITY.** Determine if the spark from each spark plug wire is satisfactory.

(30) **FUEL PUMP.** Check the fuel pump vacuum. Check the fuel pump pressure, flow, and the carburetor fuel inlet fitting.

(31) **TEST ENGINE VACUUM.** Check the vacuum at engine idle speed.

(32) **ANALYZE ENGINE COMBUSTION.** Test the engine combustion air-fuel ratio and the accelerating pump operation as a check on work performed.

(33) **WHEEL BEARINGS.** Check the front wheel bearings. If any free play is noticed, adjust the wheel bearings.

(34) **STEERING CONNECTIONS.** Check the steering connections for looseness.

(35) **STEERING GEAR.** Check the steering gear mounting bolts.

(36) **REAR SPRINGS.** Check the rear springs. Inspect the springs for sagging, broken leaves, or broken tie-bolts. Inspect the rear spring inserts. Tighten the spring clips (U-bolts) to 33-48 foot-pounds torque. Check the spring center bolt.

(37) **ROAD TEST.** Road test the car.

c. 10,000-Mile Inspection Service.

Perform the following operations in addition to the 10,000-mile lubrication service.

(1) **BRAKES.** Inspect all brake wheel cylinders for leakage.

Inspect all brake linings and drums. Check the pedal reserve and the fluid level in the master cylinder.

(2) **HEADLIGHTS.** Check the headlights and align if necessary.

(3) **WHEEL ALIGNMENT.** Check the wheel alignment and steering control.

d. 15,000-Mile Inspection Service.

In addition to the 15,000-mile lubrication service, remove, disassemble, and clean the carburetor. Remove all carbon deposits from the throttle barrel(s). Set the float level, assemble, and install the carburetor.

Adjust the carburetor as outlined in Part One, Chapter IV.

2. LUBRICATION

The lubrication recommendations given in this section should be carefully followed to reduce the possibilities of abnormal wear or damage to the various parts of the car.

The clutch release bearing hub, clutch pilot bushing, starting motor, rear springs, shock absorbers, and fan are all lubricated at the time of adjustment, replacement, or assembly, and do not require periodic lubrication. Lubrication information on these units is included in the adjustment or replacement procedures for each unit.

a. Engine Oil Changes.

The engine crankcase should be drained and refilled with new oil every 2000 miles or at least four times each year, or when the oil becomes contaminated.

NOTE: *When a new oil filter element is installed, add one quart of oil in addition to the regular capacity to fill the crankcase.*

If the car is new or the engine has been overhauled, the engine oil and filter element should be changed after the first 1000 miles of operation.

When changing engine oil, use S.A.E. 20 or 20W oil for temperatures above $+30^{\circ}$ F., S.A.E. 10W for temperatures from $+32^{\circ}$ F. to -10° F., S.A.E. 5W for sustained temperatures below -10° F.

The recommended A.P.I. minimum classification of engine lubricating oils is MM for all car and Thunderbird engines and MS for the Police Interceptor engine.

b. 1000-Mile Lubrication.

The units listed here are subjected to more wear than other units of the car and require more attention. When lubricating a car, be sure to include all of these units.

(1) **FRONT SUSPENSION BALL JOINTS.** Apply pressure gun grease at the two (2) fittings on each side.

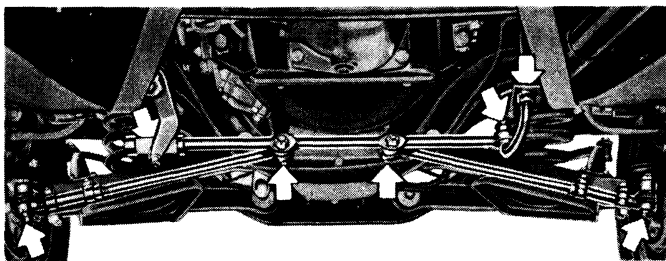

Fig. 1—Steering Linkage

(2) **STEERING LINKAGE.** Apply pressure gun grease at seven (7) fittings (fig. 1).

(3) **POWER STEERING.** Check the fluid level in the reservoir and add Automatic Transmission Fluid—Type A if necessary.

(4) **STEERING GEAR.** Check the lubricant level and add Multipurpose-Type Gear Lubricant, S.A.E. 90, as required (fig. 2).

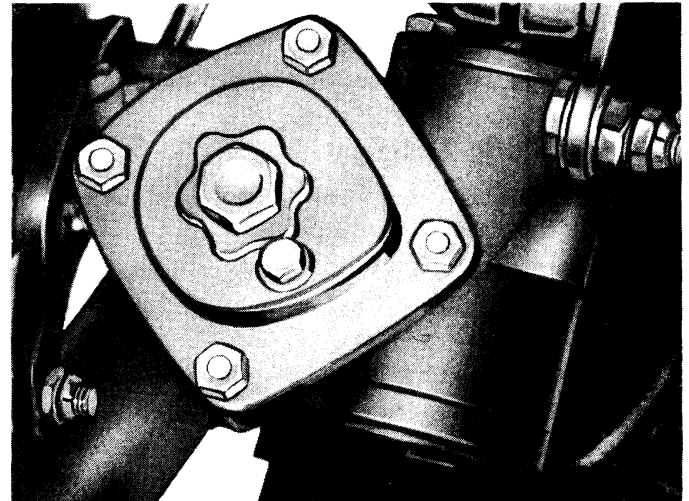

Fig. 2—Steering Gear

(5) **CLUTCH RELEASE EQUALIZER BAR.** Apply pressure gun grease at the two fittings (fig. 3).

(6) **GEARSHIFT LEVERS.** Apply pressure gun grease at the fittings shown in fig. 4.

(7) **TRANSMISSION, CLUTCH, AND BRAKE LINKAGE.** Spray all linkage with S.A.E. 10W engine oil.

(8) **STRIKER PLATES.** Coat with Wax Stick.

(9) **EXHAUST THERMOSTAT.** Apply a mixture of penetrating oil or kerosene and graphite to the thermostat shaft.

(10) **REAR AXLE.** Check the lubricant level. If the level is below the filler plug opening, add M-4642 lubri-

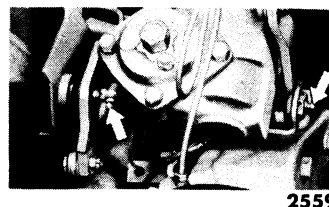

Fig. 3—Clutch Release Equalizer Bar

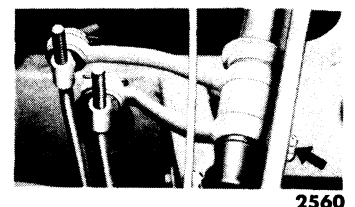

Fig. 4—Gear Shift Levers

cant or Multipurpose-Type Gear Lubricant. Use S.A.E. 90 above -10° F., and S.A.E. 80 below -10° F.

NOTE: *On new or overhauled rear axles, use only M-4642 lubricant for the first 5000 miles.*

(11) **TRANSMISSION — CONVENTIONAL OR OVERDRIVE.** Check the lubricant level. Add lubricant if the level is below the filler plug opening. Use Multipurpose-Type Lubricant, S.A.E. 80 for all temperatures.

(12) **TRANSMISSION — FORDOMATIC.** Check fluid level following the recommended procedure. Add Automatic Transmission Fluid—Type A as required.

(13) **UNIVERSAL JOINTS — THUNDERBIRD.** Apply Universal Joint Grease at the two fittings.

c. 2000-Mile Lubrication.

Perform the following operations in addition to the 1000-mile lubrication operations.

(1) **BREATHER CAP.** Wash the breather cap in a suitable solvent, then oil the element with light engine oil.

(2) **AIR CLEANER.** On the oil bath-type cleaners, drain the oil reservoir, wash the components in solvent, then saturate the maze screen with oil. Fill the reservoir with engine oil to the level indicated in the reservoir. Use S.A.E. 30 for temperatures above 32° F., and S.A.E. 10W for temperatures below 32° F.

Wash the dry-type cleaners and element in solvent and saturate the element with engine oil.

NOTE: *Service the air cleaner more frequently under severe dust conditions.*

(3) **CRANKCASE.** Drain and refill the crankcase with the recommended type and grade of engine oil.

Clean the crankcase ventilation screen on all 8-cylinder engines, except the Thunderbird engine.

d. 4000 and 5000-Mile Lubrication.

Perform the following operations at 5000-mile intervals, unless otherwise designated, in addition to the 1000-mile lubrication operations.

(1) **OIL FILTER.** Replace the oil filter cartridge each 4000 miles.

(2) **DISTRIBUTOR.** Squirt a few drops of engine

oil in the oil cup. Coat the distributor cam with a light film of distributor cam grease.

(3) **GENERATOR.** Squirt a few drops of engine oil in the oil cup (6-cylinder only).

CAUTION: *Avoid over-lubrication.*

(4) **BRAKE MASTER CYLINDER.** Check the fluid level. Add Heavy-Duty Brake Fluid (1A-19542A or B) until the fluid level is $\frac{1}{2}$ inch from the top.

(5) **DOOR, HOOD, AND DECK LID HINGES.** Spray all hinges with S.A.E. 10 engine oil.

(6) **LOCK ASSEMBLIES.** Apply lubriplate.

e. 10,000, 15,000, 20,000 and 25,000-Mile Lubrication.

Perform the following operations at the designated intervals.

(1) **PARKING BRAKE HANDLE.** Apply lubriplate to the parking brake handle shaft at 10,000-mile intervals.

(2) **BRAKE CABLES.** Apply graphite grease (M-566) to all parking brake cables at 10,000-mile intervals. Be sure the equalizer works freely.

(3) **TRANSMISSION — CONVENTIONAL OR OVERDRIVE.** Drain the transmission at 10,000-mile intervals. Refill with Multipurpose-Type Gear Lubricant, S.A.E. 80. The refill capacity of the conventional transmission is 3 pints.

The refill capacity of the Overdrive Unit on cars is 3 pints, and the refill capacity of the Overdrive Unit on Thunderbirds is $4\frac{1}{2}$ pints.

(4) **FORDOMATIC.** At 15,000-mile intervals drain the transmission, adjust the bands, then refill the transmission with Automatic Transmission Fluid—Type A.

(5) **FRONT WHEEL BEARINGS.** Clean, inspect, and repack the front wheel bearings with wheel bearing grease (8A-19585) at 10,000-mile intervals.

CAUTION: *Be sure to follow the recommended procedures.*

(6) **UNIVERSAL JOINTS—CONVENTIONAL CAR.** Repack joints with universal joint grease (0A-19572) at 20,000-mile intervals. Replace grease seals where necessary.

(7) **POWER STEERING.** Replace the fluid reservoir filter element at 25,000-mile intervals.

Part FIVE

MAINTENANCE AND SPECIFICATIONS

Chapter II

Specifications

Section	Page	Section	Page
1	357	8	363
2	357	9	363
3	358	10	364
4	358	11	364
5	359	12	364
6	360	13	365
7	362	14	365
		15	366

1. WHEELS AND TIRES

Tire	Model	Rim Type	Tire Pressure		Max. Load Capacity (Lbs.)	Static Loaded Radius (Inches)	Diam. Bolt Circle (Inches)	No. of Bolts	Offset (Inches)	Wheel Nut Torque (Ft.-Lbs.)
			Front	Rear						
6.00 x 16-4	Fairlane (8-Cyl. with Fordomatic) and all Station Wagons	D.C.	28	25	915	13.4	4½	5	0.62	55-85
6.70 x 15-4	*Thunderbird	D.C.	24	24	925	13.10	4½	5	0.62	55-85
6.70 x 15-4	All Cars except Fairlane 8-Cyl. with Fordomatic	D.C.	26	23	920	13.10	4½	5	0.62	55-85
6.70 x 15-4	Courier	D.C.	23	26	920	13.10	4½	5	0.62	55-85
7.10 x 15-4	Fairlane (8-Cyl. with Fordomatic)	D.C.	26	23	990	13.4	4½	5	0.62	55-85
7.10 x 15-4	Ranch Wagon and Courier	D.C.	26	26	990	13.4	4½	5	0.62	55-85
7.10 x 15-6	Station Wagons and Courier	D.C.	25	30	1130	13.4	4½	5	0.62	55-85

*Sustained high speed driving—30 pounds.

2. BRAKES

Model	Position	Drum Inside Dia. (Inches)	Drum Max. Boring Limits (Inches)	Lining Length Primary (Inches)	Lining Length Secondary (Inches)	Lining Width (Inches)	Lining Thickness (Inches)	Wheel Cyl. Dia. (Inches)	Master Cyl. Dia. (Inches)
Passenger Car	Front	11	11.060	10 ²⁷ / ₃₂	10 ²⁷ / ₃₂	2¼	Pri. ³ / ₁₆ Sec. ¹⁵ / ₆₄	1½	1.00
	Rear	11	11.060	10 ²⁷ / ₃₂	10 ²⁷ / ₃₂	1¾	³ / ₁₆	7/8	
Station Wagon	Front	11	11.060	9 ⁹ / ₃₂	11 ¹⁵ / ₁₆	2¼	⁷ / ₃₂	1½	1.00
	Rear	11	11.060	9 ⁹ / ₃₂	11 ¹⁵ / ₁₆	2	⁷ / ₃₂	¹⁵ / ₁₆	
Thunderbird	Front	11	11.060			Pri. 1¾ Sec. 2¼		1½	1.00
	Rear	11	11.060			1¾		7/8	

Brake pedal free travel ¼ to ⅓ inch. Lining wear limit ⅓ inch from lining surface to rivet heads.
Lining to drum clearance—0.010 inch.

3. WHEEL ALIGNMENT AND STEERING

Caster (Degrees)		Camber (Degrees)		Toe-in Front Wheels (Inches)	Tread (Inches)
Max.	Min.	Max.	Min.		
1½	½	1¼	¼	⅛ to ⅜	58*

*Thunderbird 56

AB-3504 Steering Gear

BEARINGS	
Steering Shaft & Worm Assy.	Tapered Roller
Sector Shaft Roller	Needle Bearing
Sector Shaft	Needle Bearing
Steering Column	Pre-Lubricated Ball Bearing
Sector Shaft Mfg. Max. O.D. (Inches)	1.1245

ADJUSTMENT	
Sector Shaft End Play—Steering Linkage Disconnected	No Perceptible. With Power Steering ⅛-⅝ lbs.
Worm Bearing Pre-Load (Pull to keep wheel moving)	⅛-⅝ lbs.
Steering Gear Lash Adjustments (Pull over center includes worm bearing preload)	1-1¼ lbs. With Power Steering ⅞-1¼ lbs.

Torque Specifications—Steering

Part Name	Ft.-Lbs.
Steering Pitman Arm to Idler Arm Rod Assembly	50-60
Steering Spindle Arm Connecting Rod and End Assy. to Idler Rod Assy.	45-55
Steering Spindle Arm Connecting Rod and End Assy. to Spindle Arm	45-55
Steering Spindle Connecting Rod Clamp to Adjusting Sleeve	12-20
Steering Idler Arm Mounting Bracket to Frame Assy.	28-43
Steering Idler Arm Bushing to Idler Rod Assy.	85-100
Steering Idler Arm Bushing to Idler Arm Mounting Bracket	85-100
Trans. Gear Shift Assy. to Steering Gear Assy. (Strg. Column Clamp)	12-15
Trans. Gear Shift Tube Bracket to Cap (Gear Shift Tube to Strg. Column)	8-11
Steering Wheel to Steering Gear Assy.	40-60
Steering Gear Housing Cap—Upper to Housing Assy.	12-15
Steering Gear Housing—Cover Assy. to Housing Assy.	12-15
Steering Pitman Arm to Sector Shaft Assy.	110-150
Steering Gear Assy. to Frame Assy. (Center Hole and Lower Hole)	28-43
Steering Gear Assy. to Frame Assy. (Upper Hole)	28-43
Steering Column Bracket to Inst. Panel	5-7

Torque Specifications—Power Steering

Part Name	Torque Ft.-Lbs.
Pump Support to Cylinder Head Bolts	65-70
Pump Support to Water Pump Housing Bolt	20-25
Pump Adjusting Bracket to Pump Support Bolt	20-25
Pump Belt Adjusting Bolt	30-35
Reservoir to Pump Bolts	8-11
Pump Pulley Bolt	18-20
Steering Arm Ball Stud Nut	50-60
Control Valve Sleeve Clamping Bolt	30-35
Power Cylinder Piston Rod Mounting Nut	40-50
Power Cylinder Piston Rod Locknut	40-50
Power Cylinder to Steering Arm to Idler Arm Stud Nut	60-70*
Idler Arm Nuts	50-60
Spindle Connecting Rod to Steering Arm to Idler Arm Rod Nuts	50-60
Idler Arm Bracket to Frame Bolts	30-35

*Used Nut 50-60 foot-pounds.

Torque Specifications—Front Suspension

Part Name	Ft.-Lbs.
Lower Arm Ball Joint Assembly to Spindle Nut	100 (Min.)
Upper Arm Ball Joint Assembly to Spindle Nut	80 (Min.)
Ball Joint Assembly to Upper Arm Nuts	28-43
Ball Joint Assembly to Lower Arm Nuts	65-90
Upper Arm Inner Shaft to Frame Bracket Nuts	65-90
Lower Arm to Frame Front Cross Member Nut	55-75
Lower Arm to Frame No. 2 Cross Member Nut	55-75
Upper Arm Inner Shaft to Upper Arm Nuts	60-75
Upper Arm Bumper Assembly Nut	20-35
Lower Arm Bumper Assembly Nut	20-35
Shock Absorber Mounting Plate to Lower Arm Bolts	12-20
Shock Absorber Stud Nuts	20-35
Spindle to Brake Carrier Plate Upper Nuts	28-43
Spindle to Brake Carrier Plate Lower Nuts	70 (Min.)

4. REAR AXLES

4209 Driving Gear and Pinion

Model	Gear Backlash (Inches)	Drive Gear Run Out (Inches)	Pinion Bearing Adjustment (Inch-pounds)
Car	0.003-0.008	0.003	18-24*
Station Wagon and Courier	0.003-0.008	0.003	10-30

*Used bearing 13-18 inch-pounds.

Rear Axle Ratio Specifications

Rear Axle		Thunderbird	Passenger Car 6-Cylinder 223 Cu. In.	Passenger Car 8-Cylinder 272-292 Cu. In.	Station Wagon and Sedan Delivery	Police Inter- ceptor
Axle Ratio Gear	Standard Transmission	3.73:1	3.89:1	3.78:1	4.09:1	3.73:1
	Overdrive Transmission	3.92:1	4.11:1	3.89:1	4.27:1	3.92:1
	Fordomatic Transmission	3.31:1	3.22:1	3.22:1	3.54:1	3.54:1
			3.55:1 opt.	3.55:1 opt.		
No. Pinion Teeth	Standard Transmission	11	9	9	11	11
	Overdrive Transmission	12	9	9	11	12
	Fordomatic Transmission	13	9	9	13	13
No. Ring Gear Teeth	Standard Transmission	41	35	34	45	41
	Overdrive Transmission	47	37	35	47	47
	Fordomatic Transmission	43	29	29	46	46
Pinion Back Lash	Max.	0.008	0.008	0.008	0.008	0.008
	Min.	0.003	0.003	0.003	0.003	0.003
Pinion Brg. Pre-Load	Max.—Inch-lbs.	30	24	24	30	30
	Min.—Inch-lbs.	10	18	18	10	10
Differential Side Thrust Washer			.030-.032 inch	.030-.032 inch		
Differential Pinion Gear Side Thrust Washer			.030-.032 inch	.030-.032 inch		

4211 Differential Pinion Shaft (Spider)

Model	Mfg. Dia. (Inches)
Passenger Car	0.750
Station Wagon & Courier	0.7495

4228 Differential Side Gear Thrust Washers

Model	Thickness (Inches)
Passenger Car	0.030-0.032

Torque

Name	Ft. Lbs.
Bearing Retainer Plate to Axle Housing Lock Nuts	30-35
Differential Bearing Cap Screws—Car	70-80
Differential Bearing Adjusting Nut Lock Screws—Car	15-20
Carrier to Housing Stud Nuts*	30-35
Pinion Flange to Pinion Nut*	140-150
Differential Bearing Cap Screws*	70-80

*Station Wagon & Courier

4215 Differential Pinion Gears

Model	Mfg. I.D. (Inches)
Passenger Car	0.755
Station Wagon & Courier	0.755

4230 Differential Pinion Gear Thrust Washers

Model	Thickness (Inches)
Passenger Car	0.030-0.032

Lubricant Capacity

Model	Pints
Passenger Car	4
Thunderbird, Station Wagon, and Courier	3.5

5. FRAME AND SPRINGS

5310 Front Spring Specifications

Spring Part Number	Type	Capacity at Normal Loaded Height (Pounds)*	Deflection Rate (lbs. per in.)	Height at Normal Load (Inches)	Wire Dia. (Inches)	Free Height (Inches)
AH-5310-B	Coil	1540 ± 30.0	290 ± 10	9.59	0.620 ± 0.004	14.99
AD-5310-E	Coil	2000 ± 37.5	360 ± 15	9.59	0.678 ± 0.004	15.24
AD-5310-F	Coil	2075 ± 37.5	360 ± 37.5	9.59	0.678 ± 0.004	15.45
AD-5310-G	Coil	2150 ± 37.5	360 ± 15	9.59	0.678 ± 0.004	15.66
AD-5310-H	Coil	1925 ± 50.0	445 ± 18	9.59	0.694 ± 0.004	14.09
AD-5310-J	Coil	2025 ± 50.0	445 ± 18	9.59	0.694 ± 0.004	14.32
AD-5310-K	Coil	225 ± 37.5	360 ± 15	9.59	0.678 ± 0.004	15.95
AD-5310-L	Coil	2115 ± 50.0	445 ± 18	9.59	0.694 ± 0.004	14.47

*Mean to low limit springs are identified by a white paint stripe over a minimum of 4 coils:
AD-5355-A Shim (2) required when air conditioning is installed.

5560 Rear Spring Specifications

Model	Spring Part Number	Number of Leaves	Capacity at Normal Loaded Height (Pounds)	Deflection Rate (Lbs. Per In.)	Length (Inches)	Width (Inches)	Spring Clip Torque Ft.-Lbs.
Pass. Cars (Std.)	AF-5560-C*	5	785-835	105-115	53	2.00	33-48
Station Wagon and Courier	AF-5560-H*	7	1040-1100	145-160	53	2.00	33-48
Pass. Cars (Heavy Duty)	AF-5560-F*	6	790-830	130-140	53	2.00	33-48
Thunderbird	AH-5560-H*	5	740-780	115-125	55	2.00	33-48

*Service Spring

6. ENGINES

NOTE: All specifications are given in inches unless otherwise noted.

General	ENGINE WEIGHT (total) - 625 Pounds											
	223	272				292			312			
Engine Cubic Inc. Displ.	223	8.0:1	8.4:1	8.0:1*	8.4:1*	8.0:1	8.4:1	8.4:1**	8.4:1	9.0:1	8.0:1***	8.4:1***
Compression Ratio	8.0:1	8.0:1	8.4:1	8.0:1*	8.4:1*	8.0:1	8.4:1	8.4:1**	8.4:1	9.0:1	8.0:1***	8.4:1***
Compression Press.—Sea Level @ Cranking Speed	150	160	165	160	165	155	160	160	160	165	155	160
Fuel Required	Reg.	Reg.	Reg.	Reg.	Reg.	Reg.	Reg.	Prem.	Prem.	Prem.	Reg.	Reg.
Transmission	Std., O.D. & Fordomatic	Std. & O.D.	Fordomatic	Std. & O.D.	Fordomatic	Std. & O.D.	Fordomatic	Std.	O.D.	Fordomatic	Std. & O.D.	Fordomatic
Torque Ft. Lbs. @ R.P.M.	202 @ 1600-2600	260 @ 2400	264 @ 2400	260 @ 2400	264 @ 2400	285 @ 2600	289 @ 2600	289 @ 2600	317 @ 2600	324 @ 2600	312 @ 2600	317 @ 2600
Horsepower @ R.P.M.	137 @ 4000	173 @ 4400	176 @ 4400	173 @ 4400	176 @ 4400	200 @ 4600	202 @ 4600	202 @ 4600	215 @ 4600	225 @ 4600	210 @ 4600	215 @ 4600
Taxable Horsepower	31.54	42.05				45.00			46.21			
Bore & Stroke	3.62x 3.60	3.62 x 3.30				3.75 x 3.30			3.80 x 3.44			
Firing Order	1-5-3-6-2-4	1-5-4-8-6-3-7-2 Distributor Rotates Counterclockwise Right Bank 1-2-3-4, Left Bank 5-6-7-8										
Engine Idle R.P.M. (Std. & O.D.)	475-500											
Engine Idle R.P.M. Fordomatic (Neutral) Preliminary †	475-500											
Engine Idle R.P.M. Fordomatic (Dr. Range)	425-450											
Engine Idle Manifold Vacuum Inches Hg. @ Specified Idle R.P.M. (Sea Level)	18-19	19-20										
Initial Ignition Timing BTDC (Std. & O.D.)	4°	3°										
Initial Ignition Timing BTDC (Fordomatic)	6°											
Oil Capacity (Qts.) ††	4	5										
Oil Press. (PSI) Hot @ 2000 R.P.M.	45-50											

*Special Engine. **Thunderbird. ***Police Interceptor Unit. †Final engine idle r.p.m. to be checked in drive range and readjusted to specifications if necessary. ††Add 1 quart with filter element change.

Cylinder Block

Engine Cubic Inch Displ.	223, 272	292	312
Cyl. Bore Dia.	3.6250-3.6274	3.7500-3.7524	3.8000-3.8024
Cyl. Bore Out-of-Round—Max. New Bore	0.0005	0.0005	0.0005
Cyl. Bore Out-of-Round—Max. Used Bore	0.005	0.005	0.005
Cyl. Bore Taper—Max. New Bore	0.001	0.001	0.001
Cyl. Bore Taper—Max. Used Bore	0.008	0.008	0.008
Max. Allowable Oversize Bore	0.060	0.040	0.040
Cyl. Block Head Gasket Flatness	0.003 in any 6 inches or 0.006 overall		

Cylinder Head

Engine Cubic Inch Displ.	All Engines	
Valve Seat Width	Int.	0.060—0.080
	Exh.	0.070—0.090
Valve Guide Bore Dia. Int. & Exh.	0.3430—0.3440	
Gasket Surface Flatness	0.003 in any 6 inches or 0.006 Overall	
Valve Seat Angle	45°	
Valve Seat Runout	0.0025	

Valve Mechanism*

Engine Cubic Inch Displ.	All Engines	
Valve Stem Dia. Std. (Color Coded Green)	Int.	0.3420-0.3425
	Exh.	0.3410-0.3415
Valve Stem Dia. Std. (Color Coded Red)	Int.	0.3415-0.3420
	Exh.	0.3405-0.3410
Valve Stem Dia. 0.003 Oversize	Int.	0.3445-0.3455
	Exh.	0.3435-0.3445
Valve Stem Dia. 0.015 Oversize	Int.	0.3565-0.3575
	Exh.	0.3555-0.3565
Valve Stem Dia. 0.030 Oversize	Int.	0.3715-0.3725
	Exh.	0.3705-0.3715
Valve Push Rod Runout	0.020	
Valve Seat Face Runout Int. & Exh.	0.002	
Valve Spring Free Length (App.)	2.09	
Valve Spring Out of Square (Max.)	0.062	
Valve Spring Press. (Lbs.) @ Specified Length (Valve Closed)	64-79 @ 1.780	
Valve Spring Press. (Lbs.) @ Specified Length (Valve Open)	145-177 @ 1.390	
Valve Spring Assembled Height	1 ²⁵ / ₃₂ -1 ¹³ / ₁₆	
Valve Stem to Valve Guide Clearance (Select Fit)**	Int.	0.004
	Exh.	0.005
Valve Tappet to Tappet Bore Clearance	0.0026	
Rocker Arm to Rocker Shaft Clearance	0.006	

*Valve Arrangement—
6-Cyl. Engine—Front to rear E-I-I-E-I-E-E-I-E-I-E
8-Cyl. Engine. Front to rear on both banks. E-I-I-E-E-I-I-E.
**Assemble Red Valve with Red Valve Guide and Green Valve with Green Valve Guide

Valve Timing

Engine Cubic Inch	Intake (Opens) Tappet Lift @ Degrees B.T.C.	Intake (Closes) Tappet Lift @ Degrees A.B.C.	Exhaust (Opens) Tappet Lift @ Degrees B.B.C.	Exhaust (Closes) Tappet Lift @ Degrees A.T.C.
223	24° @ 0.016	16° @ 0.019	68° @ 0.016	2° @ 0.019
272	12° @ 0.016	54° @ 0.019	58° @ 0.015	8° @ 0.018
312, 292	12° @ 0.016	54° @ 0.019	58° @ 0.015	8° @ 0.018

Camshaft

Engine Cubic Inch Displ.	223		272, 292, 312	
Camshaft Lobe Lift (Min.)	Int.	0.268	0.259	
	Exh.	0.268	0.257	
Camshaft Sprocket Front Face Runout (Assembled)	0.012			
Int. Tappet Lift (Opens) BTDC	24° @ 0.016	12° @ 0.016		
Int. Tappet Lift (Closes) ABDC	16° @ 0.019	54° @ 0.019		
Exh. Tappet Lift (Opens) BBDC	68° @ 0.016	58° @ 0.015		
Exh. Tappet Lift (Closes) ATDC	2° @ 0.019	8° @ 0.018		
Int. Tappet Lift (Opens) ATDC	14° @ 0.100	28° @ 0.100		
Int. Tappet Lift (Closes) ABDC	6° @ 0.100	12° @ 0.100		
Exh. Tappet Lift (Opens) BBDC	30° @ 0.100	18° @ 0.100		
Exh. Tappet Lift (Closes) BTDC	38° @ 0.100	34° @ 0.100		
Valve Lash (Cold) Int. & Exh.	0.019			
Valve Lash (Hot) Int. & Exh.	0.019			
Recommended Cam End Play	0.012			
Recommended Cam Journal Runout Maximum	0.005			
Camshaft Journal to Bearing Clearance—Std. Bearing	0.006			
Camshaft Journal Dia. Std.	1.9255-1.9265			

Crankshaft

Engine Cubic Inch Displ.	223	272, 292	312
Crankshaft Free End Play (Max.)	0.012	0.010	0.010
Main Bearing Journal Dia. Std.	2.4980-2.4988	2.4980-2.4988	2.6235-2.6243
Conn. Rod Journal Dia. Std.	2.2980-2.2988	2.1880-2.1888	2.1880-2.1888
Main Bearing Journal Runout (Max.)	0.004	0.003	0.003
Main Brg. Journal Out-of-Round (Max.)		0.0005	
Main Bearing Journal Fillet Radii	0.080-0.100	0.070-0.100	0.070-0.100
Conn. Rod & Main Bearing Journal Taper Length of Journal (Max.)	0.001		
Conn. Rod Journal Out-of-Round (Max.)	0.0005		
Sprocket Assembled Face Runout (Max.)	0.007		
Flywheel Clutch Face Runout (Assembled)—Std. & O.D. Trans.	0.010		
Flywheel Face Runout (Assembled)—Fordomatic	0.030		
Conn. Rod Journal Fillet Radii	0.070-0.100		

Crankshaft Main Bearings

Engine Cubic Inch Displ.	223	272, 292	312
Undersize Bearings Available	0.010, 0.020, 0.030	0.010, 0.020, 0.030	0.010, 0.020, 0.030
Journal Clearance (Select Fit) Copper Lead (Max.)	0.0035	0.0042	0.0036
Journal Clearance (Select Fit) Lead Babbit (Max.)	0.0031	0.0031*	

*272 Cubic Inch Engine Only

Connecting Rod

Engine Cubic Inch Displ.	223	272	292	312
Piston Pin—Bushing Inside Diameter—Standard Size	0.9122-0.9125	0.9122-0.9125	0.9122-0.9125	0.9122-0.9125
Piston Pin Bushing Out-of-Round (Max.)	0.0003	0.0003	0.0003	0.0003
Piston Pin Bush. Taper (Max.)	0.0003	0.0003	0.0003	0.0003
Bearing Bore Diameter Standard Size	Red	2.3120-2.3124	2.3120-2.3124	2.3120-2.3124
	Blue	2.4234-2.4238	2.3124-2.3128	2.3124-2.3128
Brg. Bore Out-of-Round (Max.)	0.0004	0.0004	0.0004	0.0004
Bearing Bore Taper (Max.)	0.0004	0.0004	0.0004	0.0004
Rod Twist Total Diff. (Max.)*	0.012	0.012	0.012	0.012
Rod Bend Total Diff. (Max.)*	0.004	0.004	0.004	0.004
Connecting Rod Side Clearance Assembled on Shaft (Max.)	0.012	0.012	0.019	0.019

*Pin Bushing and Crankshaft Bearing Bore must be parallel and in the same vertical plane within the specified total difference at ends of 8 inches long bar measured 4-inches on each side of rod.

Connecting Rod Bearings

Engine Cubic Inch Displ.	223	272, 292, 312
Undersize Bearings Available	0.010, 0.020, 0.030	0.010, 0.020, 0.030
Journal Clearance (Select Fit) (Max.)	0.0033	0.0037*

*0.0036—312 Cubic Inch Engine

Oil Pump (Gear-Type)

Engine Cubic Inch Displ.	223	272, 292, 312
Oil Press. Relief Valve Spring Tension (Lbs.) @ Spec. Lgth.	9.76-9.84 @ 1.56	10.82-10.90 @ 1.40*
Oil Pump Drive Shaft to Housing Bearing Clearance	0.0015-0.0029	0.0015-0.0029
Mfg. Oil Pump Drive Shaft to Cover Bearing Clearance		0.0015-0.0029
Oil Press. Relief Valve Piston Clearance	0.0015-0.0035	0.002-0.004
Oil Pump Gears End Clearance (Pump Assembled)	0.003-0.006	0.0015-0.005
Oil Pump Driven Gear to Shaft Clearance	0.001-0.002	0.001-0.002
Oil Pump Gears to Housing Radial Clearance	0.0015-0.006	0.0015-0.006

*7.79-7.87 @ 1.40—312 Cubic Inch Engine

Piston and Piston Pin

Engine Cubic Inch Displ.	223, 272	292	312
Piston Diameter Std.—Spread for 8 grades	3.6241-3.6265	3.7491-3.7515	3.7990-3.8014
Fitting New Piston in New Bore	Gauge Size	0.0015 x 0.5	
	Pounds Pull	5-10	
Fitting New Piston in Used Bore	Gauge Size	0.002 x 0.5	
	Pounds Pull	5-10	
Fitting Used Piston in Used Bore	Gauge Size	0.0025 x 0.5	
	Pounds Pull	5-10	
Piston Pin Dia. Std. (Color Coded Green)	0.9120-0.9123		
Piston Pin Dia. 0.001 Oversize (Color Coded Blue)	0.9130-0.9133		
Piston Pin Dia. 0.002 Oversize (Color Coded Yellow)	0.9140-0.9143		
Piston Pin to Piston Clearance (Loose) Select Fit	0.0001-0.0008 (Light thumb press fit at room temp. 70° F)		
Piston Pin to Connecting Rod Bushing Clearance (Loose) (Select Fit)	0.0008 (Light thumb press fit at room temp. 70° F)		
Piston to Cylinder Bore Clearance—Bottom of Skirt (Selective Fit)	0.004		

Piston Rings

Engine Cubic Inch Displ.		223, 272, 292	312
Ring Gap Width Std. Bore	Comp.	0.010-0.027	0.012-0.029
	Oil (Steel Rail)	0.015-0.062	0.015-0.062
Side Clearance Comp. Ring	Upper	0.006	
	Lower	0.006	

Torque Limits (Foot-Pounds)

Engine Cubic Inch Displ.	223	272, 292	312
Main Bearing Cap Bolts	95-105	95-105	120-130
Cylinder Head Bolts (Hot)	60-75	60-75	60-90
Oil Pan to Cylinder Block	12-15	12-15	12-15
Flywheel to Crankshaft	75-85	75-85	75-85
Exhaust Manifold to Cyl. Hd.	23-28	23-28	23-28
Intake Manifold to Cyl. Hd.	23-28	23-28	23-28
Oil Pump to Cyl. Block	30-35	12-15	12-15
Oil Pump to Cover Plate	12-15	12-15	12-15
Oil Filter to Cyl. Block	20-25	20-25	20-25
Cyl. Front Cover	6-9	23-28 ($\frac{3}{8}$)*	23-28
Water Outlet Conn.	23-28	12-15	23-28
Rocker Arm Cover	2.0-2.5	2.0-2.5	2.0-2.5
Cam Sprocket to Cam	45-50	35-45	15-18
Damper to Crankshaft	85-95	85-95	130-145
Conn. Rod Nuts	45-50	45-50	45-50
Conn. Rod Pal Nuts	3-4	3-4	3-4

Torque Limits (Foot-Pounds)—Cont'd

Engine Cubic Inch Displ.	223	272, 292	312
Thrust Plate Screws	12-15	12-15	12-15
Rocker Shaft to Cyl. Hd.	45-50	12-15	12-15
Valve Rocker Arm Adj. Screw Lock Nut	30-35	30-35	30-35
Push Rod Chamber Cover	1.25-1.75	2.0-2.5	2.0-2.5
Water Pump to Cyl. Block	23-28	12-15	12-15
Oil Tube to Oil Pump Nut		10-12	10-12
Oil Tube to Oil Pan Nut		28-32	28-32
Crankcase Vent Outlet Filter Cover Bolt		3-5	3-5
Fuel Pump to Cyl. Block or Cyl. Front Cover	12-15	23-28	23-28
Crankcase Vent Adapter to Cyl. Block	8-10	12-15	12-15

*12-15 for $\frac{3}{16}$ inch bolt

Torque Limits for Various Size Bolts

CAUTION: In the event that any of the below limits are in disagreement with any of those listed above, the above limits prevail.

Size (Inches)	$\frac{1}{4}$ -20	$\frac{1}{4}$ -28	$\frac{5}{16}$ -18	$\frac{5}{16}$ -24	$\frac{3}{8}$ -16	$\frac{3}{8}$ -24
Torque (Foot-Pounds)	6-9	6-9	12-15	15-18	23-28	30-35
Size (Inches)	$\frac{7}{16}$ -14	$\frac{7}{16}$ -20	$\frac{1}{2}$ -13	$\frac{1}{2}$ -20	$\frac{9}{16}$ -18	$\frac{5}{8}$ -18
Torque (Foot-Pounds)	45-50	50-60	60-70	70-80	85-95	130-145

7. CLUTCH AND TRANSMISSION

7003 Transmission (Std.)*

Type	Gear Type	Gear Ratios			
		1st	2nd	3rd	Rev.
3 Speed 8 Cyl.	All Helical	2.57	1.63	1.00	3.13
3 Speed 6 Cyl.	All Helical	2.78	1.61	1.00	3.36
Thunderbird	All Helical	2.33	1.48	1.00	2.82
Interceptor	All Helical	2.49	1.59	1.00	3.15

*Overdrive with 0.70 Ratio Optional.

Transmission Lubricant Capacities

Pints

3-Speed	Pass.	3
	Thunderbird	3 $\frac{1}{2}$
With Overdrive	Pass.	3 $\frac{1}{2}$
	Thunderbird & Station Wagon	4 $\frac{1}{2}$
Fordomatic	Cars 6-Cylinder	18 $\frac{1}{2}$
	Cars 8-Cylinder	19 $\frac{1}{2}$
	Thunderbird & Interceptor	20 $\frac{1}{2}$

Fordomatic Torque Specifications

Name	Torque Ft.-Lbs.
Converter Cover to Converter Impeller Nuts	15-28
Converter Impeller Hub to Converter Impeller Housing Bolts	8-10
Converter Housing to Transmission Case Bolts	40-45
Front Pump to Transmission Case Bolts	17-22
Front Servo to Transmission Case Bolts	30-35
Rear Servo to Transmission Case Bolts	40-45
Planetary Support to Transmission Case Bolts	20-25
Oil Distributor to Oil Distributor Sleeve Bolts	8-10
Upper Valve Body to Lower Valve Body Bolts	4-6

Fordomatic Torque Specifications (Continued)

Control Valve Body to Transmission Case Bolts	8-10
Pressure Regulator Assembly to Transmission Case Bolts	17-22
Extension Assembly to Transmission Case Bolts	28-33
Oil Pan to Transmission Case Bolts	10-13
Case Assembly—Gage Hole Plugs	7-15
Oil Pan Drain Plug	20-25
Rear Band Adjusting Screw Lock Nut	35-40
Front Band Adjusting Screw Lock Nut	20-25
Detent Lever Nut	35-40
Inner Throttle Lever Nut	17-20
Front Pump Cover Screws	25-35*
Rear Pump Cover Screws ($\frac{1}{4}$ ")	50-60*
Rear Pump Cover Screws (#10-24)	20-30*
Governor Inspection Cover Screws	50-60*
Converter Cover Drain Plug	7-10
Converter Housing to Engine Bolts	40-45
Upper Front Plate Bolts	10-15
Starter Attaching Bolts	15-20
Lower Front Plate Bolts	10-15
Rear Universal Joint Flange Bolts	20-25
Cross Member to Frame Bolts	25-32
Engine Rear Support to Cross Member Bolts	40-45
Engine Rear Support to Transmission Case Bolts	20-25
Transmission Vent Assembly	7-10
Governor Valve Body to Counterweight Screws	50-60*
Governor Valve Body Cover Screws	20-30*
Pressure Regulator Studs and Nut	40-50*
Pressure Regulator Cover Screws	20-30*
Control Valve Body Screws	20-30*
Control Valve Body Plug	10-14
Control Valve Lower Body Plug	7-15

*Inch Pounds.

7550 Clutch Disc

Model	Disc. Dia.
Pass. Cars	10"
Thunderbird & Police Interceptor	11"

7030-7160 Snap Rings

Name	Sizes Available
Main Shaft Bearing Outer	0.086"-0.088" 0.089"-0.091" 0.092"-0.094" 0.095"-0.097"
Main Shaft Speedometer Drive Gear*	0.090" 0.093" 0.096" 0.100"

*Used with Overdrive.

7563 Clutch Pressure Plate

Model	Diameter (Inches)	Pedal-Free Travel (Inches)
Pass. Cars	10	1 1/8-1 3/8
Police Cars and Thunderbird	11	1 1/8-1 3/8

Fordomatic Shift Speeds

Shift	Axle Ratio	Approximate Shift Speeds (M.P.H.)						Manual Shifts (M.P.H.)	
		2-3		3-2		2-1	1-2	2-1	2-1
		Min.	Max.	Min.	Forced	Forced	Max.	Max.	Min.
6-Cyl. Car	3.22:1	14-16	55-64	13-9	62-17	25-21	30-35	25-21	29-25
	3.55:1	13-15	52-60	12-8	58-16	23-20	28-33	23-20	28-24
8-Cyl. Car	3.22:1	14-16	58-66	13-8	65-17	26-21	32-36	26-21	30-26
	3.55:1	13-15	54-62	12-8	61-16	24-20	29-34	24-20	28-24
Thunderbird	3.54:1	14-16	55-62	13-8	61-20	16-15	29-35	28-24	24-19
Police Interceptor	3.31:1	15-17	58-66	14-9	65-22	17-16	31-37	26-30	26-21

8. COOLING SYSTEM

Radiator

Engine	6	8
Car & Station Wagon	14.5	19
Thunderbird		20

Add 1 qt. for heater.

NOTE: Cooling system on all cars is pressurized to 12-15 pounds.

Water Pump

Engine Cubic Inch Displ.	223	272, 292, 312
Impeller to Housing Clearance	0.020-0.030	0.030-0.040
Alignment Pump Pulley or Pulley Hub to Pump Housing Mounting Face	4.360 inches from front face of pulley hub.	4.480 inches from front face of pulley hub.

Drive Belt Deflections

Engine Cubic Inch Displ.	Crankshaft and Water Pump Pulley—Right Side	Generator and Water Pump Pulley—Right Side
223	1/4	
272, 292, 312		1/2

Thermostats

Type	Opens at °F	Fully Open at °F
Standard*	157-162	180
High Temp.**	177-182	200

*For use with any anti-freeze or water.

**For use with water or permanent-type anti-freeze

9. FUEL SYSTEM

Carburetor

Type	Single	Dual	Four Barrel
Fuel Level— Allowable Tolerance $\pm 1/32$	1/16 below power valve mounting surface	1/16 below top surface of float bowl	1/2 below top surface of float bowl
Float Setting (Dry)	.306 from roof of float chamber to lowest point of float (Carb. Inverted)	1.437 - 1.500 from air horn gasket surface to float bottom (Air Horn Inverted)	1/4 below top surface of float bowl
Spark Control Valve Opens (ins. Hg.)	—	6-7	8-10
Power Valve Opens (ins. Hg.)	6-7	5-6	7 1/2-9
Power Jet Assy. Ident. No.	—	—	28
Spark Control Valve Metering Jet Ident. No. (Fordomatic)	—	—	35
Spark Control Valve Metering Jet Ident. No. (Std. & O.D.)	—	—	35
Dashpot Adjustment	0.045-0.064	0.045-0.064	0.045-0.064
Main Metering Jet Ident. No. (Fordomatic)	0 to 5,000 ft.	67	50
	5,000 to 10,000 ft.	65	49
	10,000 to 15,000 ft.	63	48
Main Metering Jet Ident. No. (Std. & O.D.)	0 to 5,000 ft.	67	50
	5,000 to 10,000 ft.	65	49
	10,000 to 15,000 ft.	63	48
Secondary Venturi Jet. Ident. No.	0 to 5,000 ft.	—	73
	5,000 to 10,000 ft.	—	63
	10,000 to 15,000 ft.	—	55

Fuel Pump

Minimum Booster Pump Vacuum (Hg.) @ 500 Eng. R.P.M.	10
Fuel Pump Static Press. P.S.I. @ 500 Eng. R.P.M.	4.0-5.0
Min. Fuel Pump Vol. (Flow) @ 500 Eng. R.P.M.	1 pint in 30 seconds

Fuel Tank

Vehicle	Capacity*
Passenger Car & Thunderbird	17
Station Wagons & Courier	19

*Mounted in Vehicle

10. GENERATING SYSTEM

Generator

Part Number	Watts	Eng. R.P.M. Chg. Starts	Max. Rate		Field	Armature	Pulley Pitch Dia. (In.)	Brushes			Pulley No.
			Amp.	Eng. R.P.M.				Dia. No.	Orig. Length (In.)	Spring Tension (Oz.)	
FBV-10000-B	450	700	30	1388	FAS-10175-B	FAS-10005-A	3.00	2	0.86	26-34	FAB-10130-A
*FAR-10000-B	450	625	30	1250	FAS-10175-B	†FAR-10005-A	2.70	2	0.86	26-34	FAA-10130-A
FBT-10000-B	450	700	30	1388	FAS-10175-B	FAS-10005-A	3.60	2	0.86	26-34	FBT-10130-A
FBU-10000-B	450	830	30	1613	FAS-10175-B	FAS-10005-A	4.20	2	0.86	26-34	FBT-10130-A
FRW-10000-B	450	625	30	1250	FAS-10175-B	FAS-10005-A	3.25	2	0.86	26-34	FAC-10130-A

*Rear Bearing is bushing.

†Armature for bushing rear bearing.

Regulator

Part Number	Current Rating	Cut-In Voltage	Voltage Regulation	Current Regulation
FAP-10505-B or C	30	12.0-12.8	14.6-15.4	28-32
FBA-10505-A	30	12.0-12.8	*14.2-14.5 †14.3-14.6	*28-32 †28-33
FBB-10505-A	40	12.0-12.5	14.6-15.4	38-42
FAY-10505-B	50	12.0-12.5	*14.2-14.5 †14.3-14.6	*48-52 †48-53
FAW-10505-B	60	12.0-12.5	*14.2-14.5 †14.3-14.6	*58-62 †58-63

*Lower Stage Regulation

†Upper Stage Regulation

Batteries

Part Number	Volts	Plates	Amp. Hours	Ground
FDR-10655-G1 & G2	12	66	55	Neg.
FDR-10655-K1 & K2	12	78	65	Neg.

11. STARTING SYSTEM

Starter Motor

Part Number	Normal Engine Cranking Speed	Min. Torque @ 5 Volts		Teeth in Pinion	Teeth in Ring Gear	Gear Ratio	No Load Amperage
		Pound Ft. (Min.)	Load (Amp.) (Max.)				
FAR-11001-A	150-180	15.5	550	9	152	16.9	120

Starter Drive

Part Number	Type	Teeth Pinion	Used On
1CM-11350-C	Folo-Thru	9	FAR-11001-A

Field Coils

Part Number	Used On
70-11083—L.H.	FAR-11001-A
70-11085—R.H.	FAR-11001-A
FAR-10090-A	FAR-11001-A

Armature

Part Number	Used On
FAR-11005-A	All

Brushes

Part Number	Mfg. Length (Min.) (Inches)	Wear Limit (Inches)	Brush Spring Tension (Ounces)
18-11057	0.66	3/16	48-56

12. IGNITION

Distributor

Engine Cubic Inch	Initial Advance Crankshaft Degrees (BTC)	Distributor Advance W.O.T. Crankshaft Engine (Degrees) R.P.M.	Breaker Arm Spring Tension (Ounces)	Contact Spacing	Dwell Contact at Idle Speed	ADVANCE CHARACTERISTICS			
						Carb.	Dis-tributor R.P.M.	Advance Degrees	Vacuum Inches of Mercury
223	Std. & O.D. 4° Fordomatic 6° Maximum 8°	23°-26° @ 4000	17-20	0.024-0.026	35°-38°	Single	200	0	0
							300	0 ± 1/2	0.18
							400	1/4—1 1/4	0.32
							500	1 3/4—2 3/4	0.50
							1200	8—9 1/4	2.59
272	Std. & O.D. 3° Fordomatic 6° Maximum 10°	32°-34 1/2° @ 4000	17-20	0.014-0.016	26°-28 1/2°	Dual	200	0	0
							300	0 ± 1/2	0.15
							400	.25—1.25	0.28
							800	6.5—7.5	0.96
							1200	11.5—12 3/4	2.21
							1600	14.5—15.5	3.41
272 292 312	Std. & O.D.* 3° Fordomatic 6° Maximum** 8°	26°-28 1/2° @ 4000	17-20	0.014-0.016	26°-28 1/2°	Four Barrel	200	0	0
							300	0 ± 1/2	0.16
							400	0—1	0.29
							800	5 1/2—6 1/2	0.88
							1200	8 1/2—9 1/2	1.27
							1600	11—12	1.73
							2000	13—14 1/4	2.19

*292 Cubic Inch Thunderbird Engine available with standard transmission only.

**10° on all 292 cubic inch engines.

Coil

Engine	Primary	Secondary	Ignition Coil Amperage Draw	
	Resistance Ohms*	Resistance Ohms	Engine Stopped	Engine Idling
All	1.40-1.54 (75°F)	8000-8800 (75°F)	4.5	2.5

*Primary Circuit Resistor—1.30-1.40 (75°F)

Condenser

Engine	Capacity Microfarads	Min. Leakage Megohms	Max. Series Resistance Ohms
All	0.21-0.25	5	1

Spark Plugs

Part No.	Commercial Equivalent	Size	Gap (Inches)	Torque (Ft.-Lbs.)
FDH-12405-B	Champion #870	18 mm	0.032-0.036	15-20
RF 14 YC	Champion #21	18 mm	0.032-0.036	15-20

13. FUSE AND BULB CHART**Fuses**

	Location	Capacity
Clock Fuse All Models (except Thunderbird) Thunderbird	Clock Lead On Rear of Headlight Switch	3 Amps. 9 Amps.
Heater Cars and Thunderbird	Blower Switch Wire SFE	14 Amps.
Interior Light Fuse All Cars (Except Thunderbird)	Circuit Breaker	14 Amps.
Overdrive Fuse Cars and Thunderbird	Overdrive Relay	3AG 15
Radio Cars and Thunderbird	On Radio Signal Seaker	1AG 5 7.5 Amps.
Turn Signal Fuse Cars and Thunderbird	Flasher to Switch Lead	SFE 7.5
Courtesy Light Fuse Thunderbird	On Rear of Headlight Switch	9 Amps.
Light Circuit Breakers All Cars	On Fire Wall in Engine Compt.	30 Amps.
Park and Tail Light	On Inst. Panel to Rt. of Chg. Ind.	15 Amps.
Convertible Top Control Circuit Breaker—Pass. Car	Right Front Fender Apron	40 Amps.

Bulbs

Bulbs	Candle Power or Wattage	Trade No.	Ford Number
Headlamps Highbeam/Low Beam	50/40 W	4400	FDU-13007-A
Front Turn Signal/Parking (Combination)	32/4 c.p.	1034	FDT-15198-A
Rear Turn Signal & Stop/Tail and License (Combination)	32/4 c.p.	1034	FDT-15198-A
Stop/Tail & License (Independent or no turn signal)	32/4 c.p.	1034	FDT-15198-A
License Plate (Parcel Delivery and Courier)	3 c.p.	67	09B-13466-A
Instrument Panel Speedometer, Instruments & Radio Dial	2 c.p.	57	19B-13466
Spotlight	30 W	4435	FDT-15330-B
Engine Compartment	15 c.p.	1003 or 93	FDU-13730-A
Parking Brake Signal	2 c.p.	57	19B-13466
Automatic Cigar Lighter	1 c.p.	1445	FDU-15021-A
Stop Light Warning	21 c.p.	1141	09B-13465-B
Transmission Quadrant	3 c.p.	67	09B-13466
Back-Up Lamps	32 c.p.	1141	FDU-13465-A
Road Lamps (Thunderbird) Clear	35 W	4415	FDU-15220-A
Road Lamps (T'bird) Amber	35W	4415A	FDU-15220-B
Glove Compartment	2 c.p.	57	19B-13466
Luggage	3 c.p.	67	09B-13466
Air Conditioner Control	2 c.p.	57	19B-13466

14. PAINT

Color	Code	Part No.
Raven Black	A	M20J-1724
Nocturne Blue	B	M20J-521
Bermuda Blue	C	M20J-529
Diamond Blue	D	M20J-523
Colonial White	E	M20J-524
Pine Ridge Green	F	M20J-525
Meadow Mist Green	G	M20J-527

Color	Code	Part No.
Platinum Grey	H	M20J-532
Buckskin Tan	J	M20J-528
Fiesta Red	K	M20J-530
Goldenglow Yellow	M	M20J-531
Peacock Blue	L	M20J-534
Madrin Orange	N	M20J-533

15. TOOLS AND EQUIPMENT

The use of special tools and equipment is necessary in the performance of some service operations. The tools listed below are released for use on 1956 cars. The tool number agrees with the basic part number of the part or assembly on which the tool is used. The tools are grouped as follows; front suspension, rear suspension, engine, transmission, and miscellaneous. The tools are listed numerically in each group.

The column listing the tool source is identified as follows:

Front Suspension

Tool No.	Source	Tool Name and Purpose
T56P-1217-A	FoMoCo	Replacer—Front Hub Bearing Cups & Seal
2086-L	M	Remover & Replacer—Brake Shoe Return Spring
2035-N	KRW	
T54P-3006-B	FoMoCo	Remover Press—Spindle—Ball Joint Assembly
T54P-3044-A	FoMoCo	Overhaul Tool Kit—Front Suspension Upper & Lower Arms
T53P-3355-B	FoMoCo	Adapter Kit—Remove & Replace Idler Arm Bushings
T52L-3552-CAD	FoMoCo	Replacer—Steering Gear Lower Worm Bearing Cup
T52P-3552-FAD	FoMoCo	Remover—Steering Gear Lower Worm Bearing Cup
T52L-3576-AAD	FoMoCo	Replacer—Steering Gear Sector Shaft Bearing
T52L-3576-BAD	FoMoCo	Remover—Steering Gear Sector Shaft Bearing
3590-N	KRW	Remover—Steering Arm
3600-AA	M	Remover—Steering Wheel
3600-N	KRW	
T56L-33610-D	FoMoCo	Pressure Gauge—Power Steering System
T53P-33623-A	FoMoCo	Replacer Adapter—Oil Seal, Power Steering Pump Rotor Shaft & Cyl. Hd. Water Outlet Plug—R. H. Head

Rear Suspension

Tool No.	Source	Tool Name and Purpose
1177	M	Replacer—Axle Shaft Oil Seal
1177-N	KRW	
1225-N	KRW	Replacer—Rear Axle Shaft Bearings
1225-P	KRW	Remover—Axle Bearings
2240-A	KRW	Remover—Axle Bearing Retainer Ring
2240-N	KRW	
T52L-2275-AAD	FoMoCo	Replacer—Parking Brake Cable to Rear Backing Plate Retainer
4000-N	KRW	Spreader—Differential
4000-A	M	Housing
T56T-4020-A	FoMoCo	Pinion Depth Gauge
4067-B	M	Wrench—Differential Bearing Adjustment
4067-N	KRW	
4201-C	M	Indicator—Ring Gear Backlash
4210-P	KRW	
4201-N	KRW	Adapter—Transmission Case & Differential Carrier to Engine Stand
4205	M	Holder—Differential Housing
4221-C	M	Remover—Differential Bearing Remover—Case Cover—Power Divider
4221-F.L.M.	M	Replacer—Differential Bearings
4221-N-4	KRW	Replacer—Pinion Bearings
4222-N	KRW	Replacer—Differential Bearings
4234	M	Remover & Replacer—Rear Axle Bearings
4235-A	M	Remover—Axle Shaft & Bearing
4235-N	KRW	
4245-B	M	Replacer—Axle Bearing Oil Seal
T56P-4610-A (Use with 4610-A or 4610-P)	FoMoCo	Adapter Rings—Pinion Depth Gauge
4610-A	M	Gauge Pinion Depth
4610-P	KRW	
4610-PP	KRW	Gauge—Master Pinion (To measure Pinion Depth)
4610-CC	M	
4209-C	M	Scale—Pinion Tension
4610-N	KRW	
4616	M	Replacer—Pinion Shaft Front Bearing Cup
T55P-4616-A	FoMoCo	Remover & Replacer—Rear Axle Pinion Bearing Cups
T53T-4621-B	FoMoCo	Replacer—Pinion Bearing Cones
4621-B	M	Remover—Rear Pinion Bearing
4621-N	KRW	Remover—Drive Pinion Rear Bearing Cone

FoMoCo Tools available from the Ford Division, Parts and Accessories Department

KRW —Tools available from K. R. Wilson, Inc., 215 Mill St., Arcade, New York.

M —Tools available from Manzel, Inc., 315 Babcock St., Buffalo 10, New York.

Any shop performing services on Ford cars will find it is advisable to secure these tools or their equivalent.

Rear Suspension—continued

Tool No.	Source	Tool Name and Purpose
4628-F	M	Replacer—Drive Pinion Bearing Cups
4628-P	KRW	Remover—Front & Rear Pinion Bearing Cup
T55P-4676-A	FoMoCo	Replacer—Pinion Shaft Oil Seal
T53T-4851-A	FoMoCo	Remover—Flange (Universal Joint) Axle End
T53T-4851-E	FoMoCo	Holder—Flange (Universal Joint) Axle End
4858-B	M	Replacer—Pinion Bearing & Companion Flange
4858-D	M	Remover—Companion Flange
4858-N	KRW	Socket—Companion Flange Nut
4858-E	M	Replacer—Companion Flange and Pinion Bearing
4858-P	KRW	
5560-N	KRW	Lifter—Rear Spring Leaf

Engine

Tool No.	Source	Tool Name and Purpose
LM-106	M	Tester—Valve Springs
T53L-6000-B	FoMoCo	Hooks—Engine Lifting
T52L-6000-C	FoMoCo	Engine Lifting Hook
T54L-6005-C	FoMoCo	Adapter—Engine Assembly to Repair Stand Mount
T54L-6005-D	FoMoCo	Mount & Spindle—Engine to Repair Stand (KRW type)
T54L-6005-E	FoMoCo	Mount and Spindle—Engine to Repair Stand (Manzel and early KRW)
T52T-6005-CJD	FoMoCo	Engine Mount—Engine to Repair Stand—Splined Shaft KRW
T52T-6005-KJD	FoMoCo	Engine Mount—Engine to Repair Stand—KRW or Manzel Keyed Shaft
T54L-6015-A	FoMoCo	Replacer Adapter—Cylinder Block & Cylinder Head Core Plugs
T52L-6059-AAE	FoMoCo	Pilot—Crankshaft Front Cover Oil Seal
T54L-6085-A	FoMoCo	Holding Fixture—Cylinder Heads
T52L-6085-AEE	FoMoCo	Reamer Kit—Valve Guides
T52P-6085-DAD	FoMoCo	Holding Fixture—Cylinder Head
FLM-6110-A	M	Piston Pull Scale
T52L-6110-AAD	FoMoCo	Cleaner—Piston Ring Groove
T52P-6135-DAD	FoMoCo	Remover—Piston Pin
T52T-6135-CJD	FoMoCo	Remover—Piston Pin Replacer—Cyl. Head Water Outlet Plug, LH Head
FLM-6149 699	M KRW	Compressor—Piston Ring
T52L-6149-AED	FoMoCo	Expander—Piston Ring
M-120-RA-72	M	Fixture—Connecting Rod Alignment
T54T-6250-B	FoMoCo	Remover & Replacer Adapters—Camshaft Bearings
T52L-6261-CEE	FoMoCo	Remover & Replacer—Camshaft Bearings (Additional Adaptors Required for 1954-1956)
T52L-6266-BGD	FoMoCo	Replacer—Cylinder Head Core Plug, Cyl. Block Core Plugs & Camshaft Bearing Bore Plug
6303-C 6303-N&P	M KRW	Wrench—Engine Turning (Engine Removed)
T52L-6306-AEE	FoMoCo	Replacer—Crankshaft Sprocket & Crankshaft Damper also used with Tool T53P-3355-B
T52L-6316-FEE	FoMoCo	Remover—Crankshaft Damper or Pulley
6392-N	N	Adapter Plate—Check Runout Flywheel Housing (For Service Fix)
6513-CC	M	Valve Micrometer—Exhaust Valve
6513-EE	M	Compressor—Valve Spring
T52L-6700-BEE	FoMoCo	Replacer—Crankshaft Front Cover Oil Seal
T52L-6701-AGD	FoMoCo	Forming Tool—Crankshaft Rear Oil Seal
T52L-8501-DAD	FoMoCo	Kit—Water Pump Overhaul (Adaptors Required for 54, 55, and 56)
T55L-8512-A	FoMoCo	Replacer—Impeller Ring—Water Pump (Used with T52L-8501-DAD)
T56L-9350-A	FoMoCo	Overhaul Tool Kit—Fuel Pump

Engine—continued

Tool No.	Source	Tool Name and Purpose
T52T-9400-BJE	FoMoCo	Remover & Replacer—Fuel Pump Push Rod Retaining Clip
T52L-9510-AHD	FoMoCo	Gauge—Carburetor Float Level (Hi-Lift Nozzle Bar Carburetor)
T52L-9550-AGE	FoMoCo	Gauge—Carburetor Fuel Level
T54L-9550-C	FoMoCo	Gauge—Fuel Level
T56L-9562-B	FoMoCo	Gauge—Carburetor Fuel Level
T49L-9904-A	FoMoCo	Fixture—Checking Carburetor Power Valve Diaphragm
T56L-10505-A	FoMoCo	Thermometer—Voltage Regulator Setting
10505	M	Remover & Replacer—Voltage Regulator Rivets
10505-R	KRW	
10505-C2	M	Wrench—Generator Regulator Adjusting
10505-N	KRW	
10505-P	KRW	Tension Scale—Generator Regulator
T52L-12131-CAD	FoMoCo	Remover & Replacer Fixture—Distributor Shaft Gear & Collar Retaining Pins
12132	M	Burnisher—Distributor Shaft Bushings
12132-Q	KRW	
12132-A	M	Replacer—Distributor Shaft Bushings
12132-P	KRW	
12132-B-1	M	Remover—Distributor Shaft Bushings
12132-N-1	KRW	
T52L-12132-CGD	FoMoCo	Holding Fixture—Distributor
T52T-12132-DJD	FoMoCo	Holding Fixture—Distributor Body
12150-D	M	Wrench—Distributor Adjustment
12150-N	KRW	
12151	M	Tension Scale—Distributor Points
12151-N	KRW	
T52L-12390-CAD	FoMoCo	Remover Kit—Distributor Shaft Gear
T52L-12390-DED	FoMoCo	Fixture—Distributor Gear, Locating & Installing

Transmission

Tool No.	Source	Tool Name and Purpose
1175-AE	M	Remover—Fordomatic Front Pump and Extension Housing Oil Seal & Steering Gear Lower Worm Bearing Cup
4676-N (also see "Rear Suspension")	KRW	Remover—Oil Seal—Transmission Extension & Overdrive
M-7000-CR	M	Oil Drain Can with Removable Filter
7000-SW	KRW	
7000-CC	M	Holder—Transmission Assembly & Disassembly
7000-W	KRW	
7000-DD	M	Tip—Air Nozzle
7000-NW	KRW	
7000-DE	M	Air Nozzle Assembly with Rubber Tip
7000-E	M	Jack—Transmission—High
T52L-7000-GAE	FoMoCo	Remover—Transmission Extension Housing Rear Bearing
T52L-7000-HAE	FoMoCo	Replacer—Transmission Extension Housing Rear Bearing
7052-N	KRW	Replacer—Drive Shaft & Overdrive Oil Seal
7059-N	KRW	Pliers—Snap Ring
7064	M	
7105-B	KRW	Replacer—Synchromesh Hub
T55P-7111-A	FoMoCo	Shaft—Cluster Gear Roller Retainer

Valve Lash Adjustment - Practical Method

The Y-Block tappet adjust screw has 20 threads per inch. One turn represents .050" of linear travel. Multiply 1 turn times existing rocker ratio. Example for 1.54:1 ratio rocker arms; .050" X 1.54 = .077". One full turn of the adjust screw will represent .077" of tappet clearance. Now divide one turn of tappet clearance i.e., .077" by 60 (as in the 60 minutes of a clock dial). This number is .001283" = 1 minute of clock face rotation. Thus 15 minutes of rotation will = .0192" which is very close to .019" (which is the specification for valve tappet clearance on 292 and 312 engines).

***15 minutes clock rotation = 90 degrees rotation; a scale easily understood and a very close estimate to .019".

With the lifter all the down, start tightening the adjustment screw until the pushrod turns freely to obtain some tappet clearance at .000" valve lash - just touching but not depressing the valve. Now rotate the adjust screw counterclockwise 90 degrees. The resulting clearance should be very, very close to .019" regardless of rocker arm face wear.

Adjusting standard, low ratio, 1.43:1 rockers:

$$.050" (1 \text{ turn}) \times 1.43 (\text{ratio}) = .0715" / 60 (\text{min}) = .0011916 \times 16 (\text{min}) = .0190656"$$

Rotate the adjust screw 16 min. of rotation counterclockwise, to obtain .01906" clearance.

To determine the rocker arm ratio, observe the casting number on the side. 1.54 rockers are marked ECG 6564-B2 or -B1.

Rockers without suffixes and casting #5751066, are standard 1.43:1 ratio.

Transmission—continued

Tool No.	Source	Tool Name and Purpose
T56P-7111B	FoMoCo	Shaft—Cluster Gear Roller Retainer
7113-N	KRW	Hook—Cluster Gear Alignment
7195	M	Wrench—Rear Band Adjusting
7195-W	KRW	
7225	M	Wrench—Front Band Adjusting
7225-W	KRW	
7563-A	M	Pilot—Clutch Disc Alignment
7563-N	KRW	
T49P-7580-A	FoMoCo	Replacer—Clutch Release Bearing
7600-E	M	Remover—Clutch Pilot Bearing and Core Plugs
7600-N	KRW	
7657	M	Replacer & Pilot—Extension Housing Oil Seal
7657-W	KRW	
T55P-7657-A	FoMoCo	Replacer—Trans. Ext. Housing Oil Seal
7675-N	KRW	Remover—Overdrive Free Wheeling Unit
7688-N	KRW	Replacer—Oil Seal Lockout Lever
7946	M	Replacer—One Way Clutch Inner Race (Overdrive)
7946-W	KRW	
7975	M	Guide Pins—Transmission to Converter Assembly
7975-W	KRW	
77067	M	Extension—Dial Indicator Support
77067-W	KRW	
T55L-77270-C	FoMoCo	Gauge—Protractor—Transmission Throttle Control Lever
77288	M	Replacer—Manual Shaft Oil Seal
77288-W	KRW	
77515	M	Compressor—Rear Clutch Spring
77515-W	KRW	
77530	M	Holder—Primary, Secondary Clutches & Converter Assembly
77530-W	KRW	
77565	M	Compressor—Front Clutch Spring
77565-W	KRW	
77763	M	Bending Tool—Throttle Valve Stop
77820	M	Pressure Gauge & Attaching Hose
77820-W	KRW	
77837	M	Replacer—Front Pump Oil Seal
77837-W	KRW	
77869	M	Remover & Replacer—Rear Pump Discharge Tube
77869-W	KRW	
6915-AA	M	Positioning Tool—Overdrive Pawl
6916-N	KRW	
6919-L	M	Wrench—Overdrive Governor
6919-N	KRW	

Miscellaneous

Tool No.	Source	Tool Name and Purpose
T50T-100-A	FoMoCo	Hammer—Impact
T53L-200-A	FoMoCo	Handle Adapter
T53L-300-A	FoMoCo	Sling—Engine Lifting
T56L-400-A	FoMoCo	Puller
T52L-16800-AAD	FoMoCo	Replacer Tool—Hood Hinge Clock Spring
17470	M	Wrench—Retaining Unit—Wiper—Heater & Lite Connector
17470-N	KRW	
T52P-18918-AAD	FoMoCo	Wrench—Radio Antenna Mounting
T56P-19670-A	FoMoCo	Remover & Replacer—Front Bearing Housing Cover and Seal Assembly
T56P-19700-A&B	FoMoCo	Air Conditioning Tool Kit
50100-N	KRW	Button Press—Convertible Top

